

129.104:734

U.S. Department

Clemson University



3 1604 019 750 357

Technical Preservation  
Services

Preservation Case Studies

# Improving Thermal Efficiency: Historic Wooden Windows

## The Colcord Building Oklahoma City, Oklahoma



PUBLIC DOCUMENTS  
DEPOSITORY ITEM

NOV 17 1982

CLEMSON  
LIBRARY

*The Colcord Building, exterior view of historic wooden windows. (Photo: Jack Graves, AIA)*

U.S. Department  
of the Interior

National Park  
Service

Technical Preservation  
Services

Preservation Case Studies

# **Improving Thermal Efficiency: Historic Wooden Windows**

**The Colcord Building  
Oklahoma City, Oklahoma**

**Sharon C. Park AIA**

## TABLE OF CONTENTS

Introduction and Project Description	1
Alternative Window Treatments	2
Designing the Interior Storm Panels	4
Federal Grants for Historic Preservation	4
Federal Tax Assistance for Historic Preservation	5
Retrofitting the Historic Windows	6
Conclusion	12
Additional Reading	13
Technical Preservation Services Publications	14
Comment Form	15
Acknowledgements	17



Figure 1. *The Colcord Building, Oklahoma City, Oklahoma. This 12-story poured-in-place concrete building with terra-cotta ornamentation was built in 1910 and is individually listed on the National Register of Historic Places. (Photo: H. Ward Jandl)*

#### INTRODUCTION AND PROJECT DESCRIPTION

When rehabilitating historic structures, many owners and architects mistakenly assume that the existing wooden window sash, no matter what their condition, must be replaced in order to improve thermal efficiency. This case study shows how one building in Oklahoma City was able to retain its historic window sash through careful repair, or retrofitting, and the installation of an interior storm panel. Through the architect's and

owners' sensitivity and willingness to objectively explore alternatives, an aesthetically pleasing, thermally efficient, and cost effective solution resulted.

The Colcord Building, erected in 1910, is one of the few remaining historic office buildings in downtown Oklahoma City (see figure 1). It was listed in the National Register of Historic Places in 1976, and in 1979, under new ownership, the rehabilitation of the building began. One of the objectives in rehabilitating this 12-story poured-in-place concrete building, in addition to modernizing the elevators and office space, was to improve its overall thermal efficiency.

The Colcord Building, for years the landmark high-rise of downtown Oklahoma City, was designed by William A. Wells, a follower of the noted American architect Louis H. Sullivan. Sullivan's influence is apparent in Wells's use of richly ornamented terra-cotta panels on the 1st, 2nd, and 12th floors, especially as surrounds to the entrances and the highly articulated triple windows on the 2nd floor ( see figure 2).

Wells's use of the decorative terra-cotta is part of the historic significance of these windows. The rich surface quality of the masonry is contrasted by the bold scale and setbacks of the second floor windows and the double-hung pairs of remaining windows. While the ornamentation of the first 2 floors with terra-cotta gives a strong horizontal character to the building's base, the paired windows from the 3rd to the 12th floor create vertical bands that accentuate the height of this tower structure. The location, composition, articulation, and detailing of the windows are, therefore, significant design features the owners and the architect wanted to respect in the rehabilitation.

The Technical Preservation Services Division (TPS) of the National Park Service (NPS) was contacted during the planning stages of the rehabilitation as the owners were considering applying for tax benefits under the Tax Reform Act of 1976 and the Revenue Act of 1978. This process has changed somewhat since the owners first contacted TPS (see pages 4 and 5).

#### ALTERNATIVE WINDOW TREATMENTS

Because one of the primary objectives of the rehabilitation of the Colcord Building was to improve the overall thermal efficiency of the building, attention focused on the existing single glazed wooden sash, 507 window units with approximately 7,700 square feet of exterior surface exposure. Cold air that filters through loose fitting, single glazed windows can consume up to 25 percent of space heating costs, so it was financially important that the thermal performance of the windows be improved. This could be achieved through implementing some of the following options: repairing the existing windows to tighten them in their frames, adding new



Figure 2. *Original second-floor wooden windows of the Colcord Building. Note the high degree of ornamentation with the composition of the triple windows, the deep setbacks, the paired Corinthian columns, and the Sullivanesque terra-cotta panels surrounding the windows. The windows on the upper floors are of a simpler composition being paired one-over-one double-hung windows.*  
(Photo: Jack Graves, AIA)

weather stripping, adding a second layer of glazing, or replacing the entire window unit with a thermal unit.

The owners' concerns regarding cost effectiveness led them to ask the architect for advice on improving the windows' thermal efficiency. Because of the architect's strong commitment to preservation, he immediately eliminated two options that have found popular application in renovation work. The first was the use of an exterior storm window, which was cost effective, but which, in the case of the Colcord Building, was not appropriate. The deepset windows were an integral part of the building's original design, and the use of exterior storm windows resulting in the loss of the deep setbacks would have altered the building's exterior appearance. The second option dismissed was the use of a solar tinted thermal replacement window, which also would have had a negative visual impact on the historic exterior. The contrast of the dark windows with the light colored terra-cotta and concrete walls would have altered the building's character.

## FEDERAL GRANTS FOR HISTORIC PRESERVATION

Grants on a 50 percent matching basis are issued to states, the District of Columbia, and the National Trust for Historic Preservation. Funds may be used for surveys in the state, preparation of historic preservation plans, preparation of nominations to the National Register, and where funding permits, for the acquisition and development of properties listed in the National Register.

The U.S. Department of the Interior makes grants to the states; these funds may be transferred by the State Historic Preservation Officers (SHPOs), to private organizations, individuals or governmental subdivisions.

The architect recommended retaining the original wooden sash windows, which were in good condition, and exploring the possibility of installing interior storm windows. The owners, however, were impressed with the literature available on metal framed replacement thermal windows and asked the architect to consider the financial and thermal benefits of a replacement window. At that time, it was difficult to determine the cost of a retrofitted window, but the cost per unit of the metal framed, double-glazed, double-hung replacement window was approximately \$300.

Because the architect was concerned that removing the historic window sash and replacing them with metal units might not conform to the "Secretary of the Interior's Standards for Rehabilitation," he encouraged the owners' managing partner to contact TPS for a ruling. At the time, TPS was responsible for reviewing and certifying rehabilitation work for tax purposes. Since October, 1980, this responsibility has shifted to the regional offices of the National Park Service.

After a review, TPS concurred that replacing the original wooden windows with an aluminum replacement sash would substantially alter the character of the historic building. TPS also suggested that the use of a metal framed window assemblage could cause a serious moisture problem with the terra-cotta exterior of the building. Condensation, which forms on metal frames, could migrate into the wall cavity adjacent to the window and become trapped moisture. As this terra-cotta was glazed, it was impermeable, and the trapped moisture could cause spalling and, therefore, deterioration of the historic building fabric.

Because these two items, loss of character and damage to historic fabric, violated the Secretary of the Interior's "Standards for Rehabilitation," TPS determined that no tax benefits would be given if the metal windows were used. Since the metal windows were no longer a viable option for the owner, the architect proceeded with his original proposal to retrofit the historic wooden sash.

### DESIGNING THE INTERIOR STORM PANELS

While researching commercially available thermal windows, the architect had noticed a new window unit that came equipped with a "piggy-back," or removable, interior storm panel. This second layer of glazing was recessed into the primary wooden sash, which allowed the double-hung unit to be fully operational. The lower sash could be raised without interference from the applied storm panel on the upper sash. The architect wanted to incorporate this feature into the Colcord Building, but first he wanted to be assured that the historic windows would not be structurally damaged or weakened by this modification.



FEDERAL TAX ASSISTANCE FOR  
HISTORIC PRESERVATION

Rehabilitation Work  
Undertaken Between  
June, 1976-December, 1981

Section 2124 of the Tax Reform Act of 1976 (extended by the Tax Treatment Extension Act of 1980) offers important tax incentives for the rehabilitation of historic buildings. Owners of eligible depreciable structures may amortize qualified rehabilitation expenses over a 5-year period or take accelerated depreciation on the value of the rehabilitated property. A third incentive, an investment tax credit for rehabilitation, is available under section 315 of the Revenue Act of 1978.

The National Park Service reviews the proposed rehabilitation, and upon completion of the approved work, issues the necessary certification to qualified owners of depreciable historic buildings for the incentives provided by these laws. The Internal Revenue Service, U.S. Department of the Treasury, makes determinations regarding the tax consequences of these certifications.

The architect's two concerns were the routing, or rabbeting, of the windows' wooden rails and stiles and the impact the additional weight of the storm panels would have on operating the windows. The cross-section of the sash rails and stiles was 1 7/8 by 2 inches of solid wood in good condition. The proposed rabbet of 1/2 by 3/8 inch was, therefore, not substantial enough to weaken the windows. This rabbeting would still allow a thermal cavity of a full inch between the glazing layers. The second concern was whether the existing sash weights could tolerate the additional weight of the storm panels. The Colcord Building windows vary from 22 by 66 inches to 48 by 66 inches and are composed of an upper and lower sash. The corresponding weight of the storm panels was approximately 3 to 8 pounds. The architect determined that the existing sash weights were adequate and specified that the pulleys of the sash chains be lubricated during the retrofitting to ease operating the heavier windows. (see figure 3)

Through an analysis of the existing conditions and calculations to determine the stress that would be placed on the historic window, the architect concluded that the use of a recessed interior storm panel was feasible. In the case of the Colcord Building, the determining factors were: 1) the windows were in good condition; 2) the rails and stiles were dimensionally substantial and, in most cases, there were no interior muntins dividing the sash; and 3) the sash weights were adequate for the heavier window assembly.

A major drawback, however, of adding a second layer of glazing to wooden window sash is the potential problem of condensation. A layer of moisture can form on the warm side of a cold window when moist, humid air reaches its dewpoint and condenses. This condensation then runs down the window glass and settles on the wood bottom rail; if it is trapped between two layers of glass, it can eventually rot out the window sash. The condensate associated with the wooden window is likely to have a negative effect on the wooden sash, unlike the previously proposed metal window which could "sweat" through the metal frame and cause even more damage to the surrounding masonry. The architect addressed the problem of condensation by designing an appropriate storm panel.

One way to reduce the chance of a condensation problem is to reduce the humidity of the inside air. In an office building, such as the Colcord, the humidity is generally kept at a low level, and there are seldom any sources of high humidity associated with residential functions. To reduce the chance for condensation occurring between the two glazing layers, the architect specified the installation of both a neoprene gasket integral with the metal frame of the storm panel and venting holes in the wooden sash stiles. The gasket, a flexible membrane cushion, acts as a sealer to keep

FEDERAL TAX ASSISTANCE FOR  
HISTORIC PRESERVATION

Rehabilitation Work  
Undertaken After  
January, 1982

Section 212 of the Economic Recovery Tax Act of 1981 contains significant revisions to the historic preservation tax incentives outlined on page 5. Among other things, this law replaces the 1976 and 1978 incentives with a 25% investment tax credit for substantial rehabilitations undertaken on historic commercial, industrial and rental residential buildings. This credit may be combined with a 15 year cost recovery period for the adjusted basis of the historic building.

The certification process described in this case study remains intact under the new law.

moist air from penetrating into the cavity between the two layers of glazing. The vent holes, drilled laterally through the sash stiles, were to provide a minimum amount of circulation within the cavity to reduce condensation. (see figure 3)

The method for mounting the storm panels posed the final problem for the architect. The commercially available new window units with integral storm panels used concealed retractable clips to hold the panels in place. These clips also allowed for easy removal of the storm panels. The architect, however, determined that in the case of the Colcord Buildings, it would be advantageous to have the insulating qualities of the storm panels all year. The panels would not be removed except for maintenance purposes. Because the clips would have added to the cost of the project, and because they would have required deeper routing of the historic sash, the architect chose to have the panels screwed into place (see figure 4). An electric screw gun can be used to quickly remove the storm panels for cleaning or for painting the sash.

The architect had the option of using acrylic or glass as the material for the new "piggy-back" storm panels. Acrylics are beginning to be successfully used in interior storm panels, and the architect wanted to investigate the advantages of using this material. Acrylics are purported to be 40-percent lighter than glass, 15-percent more thermally efficient than glass, and shatter resistant. The drawbacks, however, are that acrylics are generally more expensive, tend to bow because they are less rigid, can discolor over time if exposed to the sun, and must be carefully cleaned to avoid scratches. Because 1) the window sash of the Colcord Building could tolerate the additional weight of glass storm panels; 2) the insulating qualities of glass were acceptable to the owner; and 3) the price of glass was economical, the architect specified glass storm panels, in this case.

#### RETROFITTING THE HISTORIC WINDOWS

Because the building was to remain partially occupied during the rehabilitation, it was important for the construction manager to develop an efficient system to repair the windows and install the storm panels. In order to reduce disruption to the tenants, the work on windows in occupied suites was scheduled for after 5 p.m. The window contract was handled by two-man crews who could complete six windows in an evening shift. To accomplish the work as efficiently as possible, a temporary shop with the appropriate jigs and benches was set up on the floor where the men were working. This shop moved with the men as they progressed through the building.

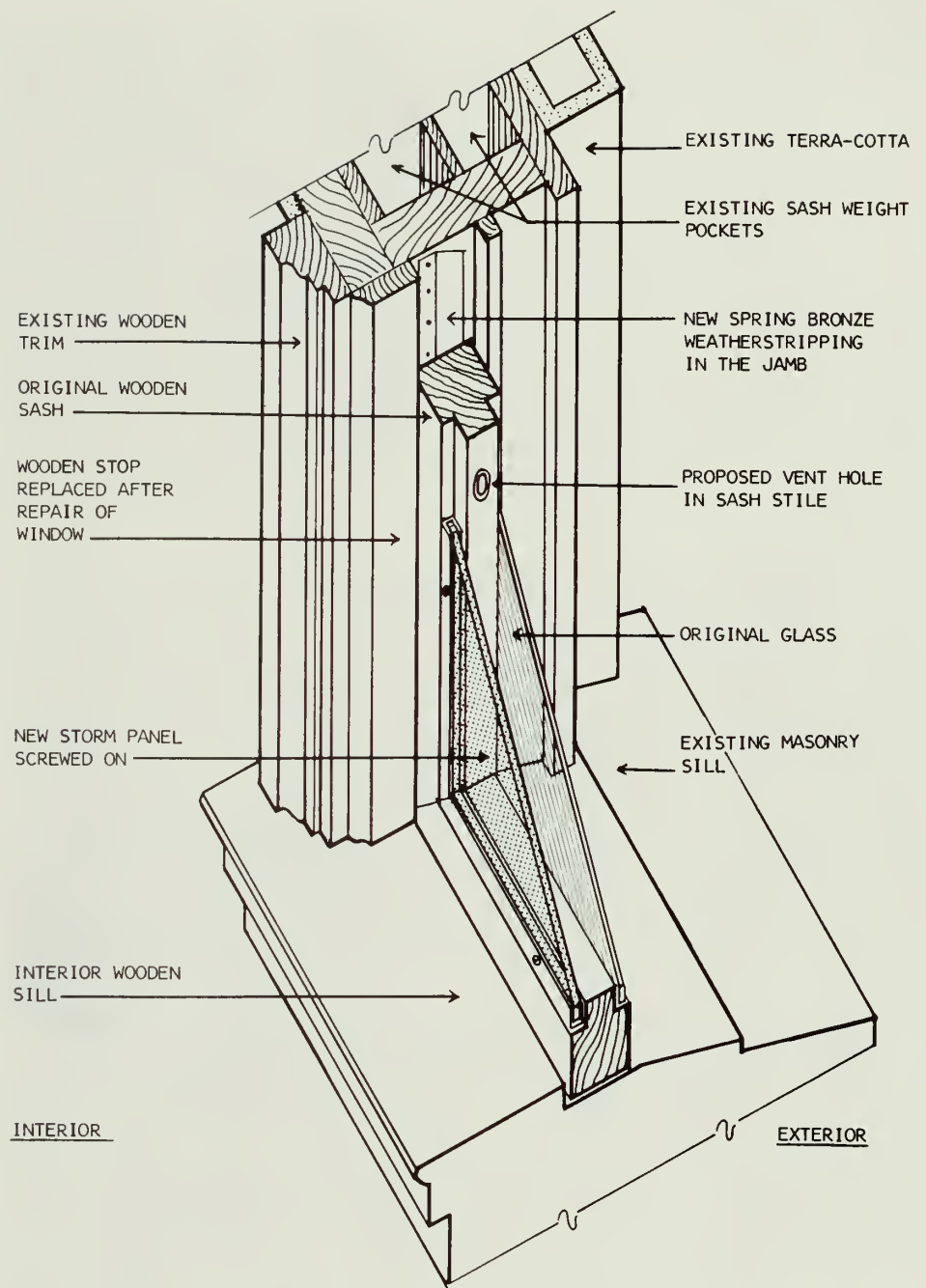

Figure 3. Cutaway view of the window showing the proposed interior storm panel in place. Note the new weather stripping on the frame of the window and the proposed vent hole on the wooden sash stile.

The workmen set up an assembly line process that greatly improved their efficiency. First, the sash had to be removed from the window frame by removing the parting bead and stop from one side of the window jamb. While the sash were out of their frames, the frame itself could be repaired, old paint scraped off, and new spring-bronze weather stripping installed. The new weather stripping was essential to the retrofitting process because it can reduce 20-percent of the air infiltration by tightening the sash in their frames. Also, the sash pulleys were lubricated to ease the operation of the windows, and a temporary plywood panel was installed in the opening while the sash were being repaired.

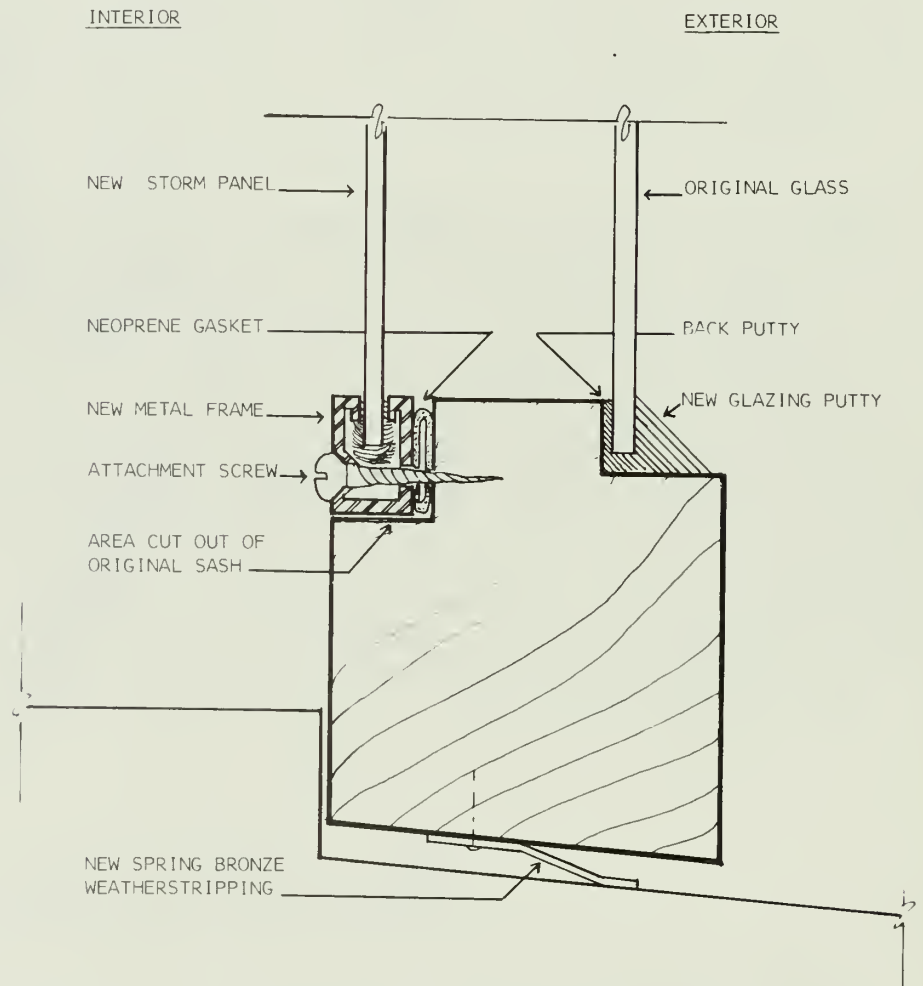
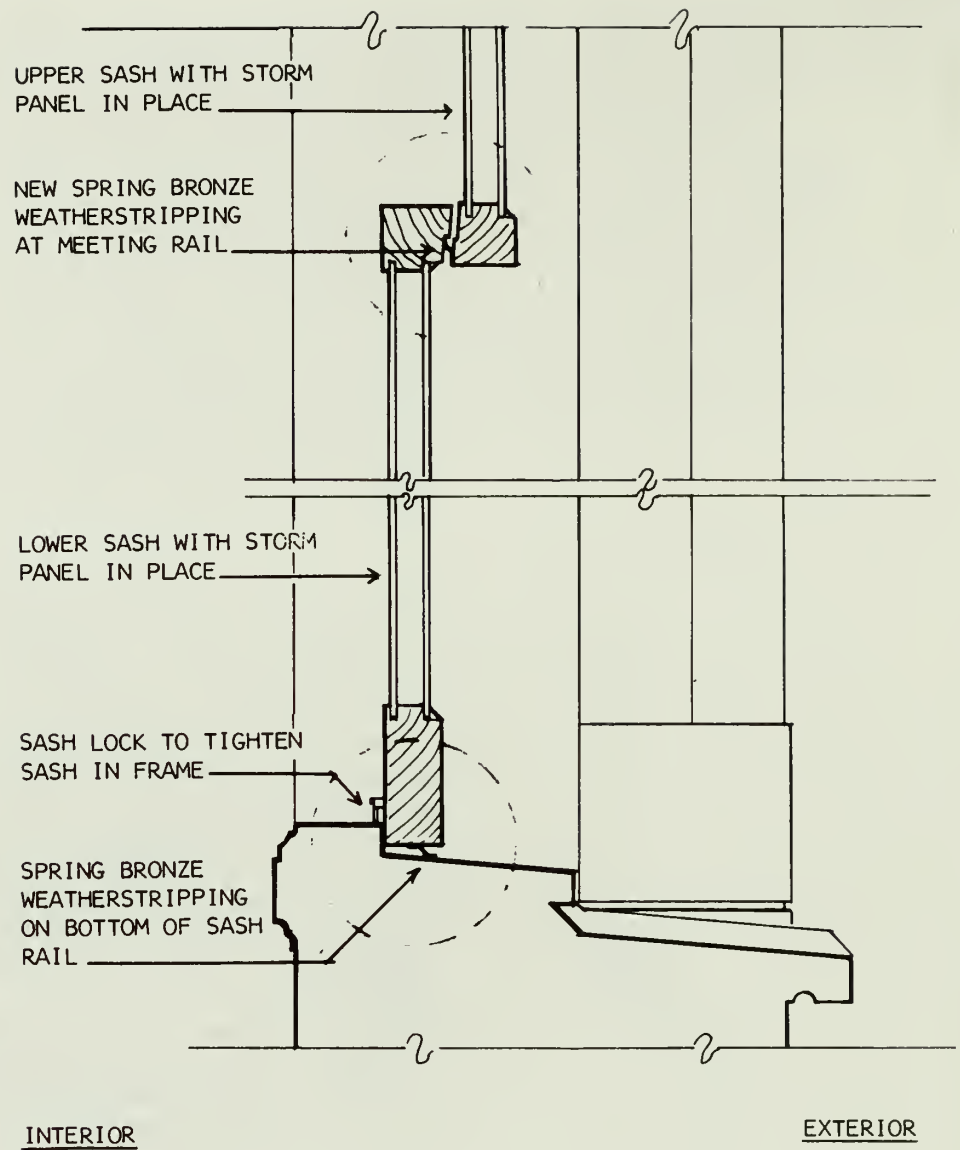

Figure 4. Detailed section through the wooden sash rail with storm panel in place. Note the small area of wood cut out to recess the new storm panel. The cavity left between the two glazing layers is 1 inch which is within the optimum range on 1/4 inch to 1 1/4 inch for insulated glazing. Note the neoprene gasket that acts to seal out moist air between the storm panel and the wooden window.

Each window sash was taken, in turn, to the workbench where it was prepared for the new storm panel. The glass was carefully removed and set aside. Then a 1/2 by 3/8 inch rabbet was cut from the inside surface of the wooden sash to receive the recessed storm panel (see figures 3 and 4). The loose paint and any remaining dry glazing putty was scraped and removed from the sash. The glass was then reinstalled with a modern glazing compound and a new piece of spring metal weatherstripping was applied to the underside of the lower sash rail before it was returned to its frame (see figure 5). The original window sashes were equipped with sash locks at the head and sill, and the architect determined that these locks should be kept fastened at all times to insure that the windows would remain tight in their frames.

As part of the retrofitting, the architect had originally specified that the cavity between the two layers of glass be vented. Through a misunderstanding with the carpenters, the vent holes were omitted. Fortunately, however, through four seasons of monitoring, there has been no problem with condensation occurring between the glazing at the Colcord Building. While each geographic area of the country will have its own climatic conditions, it appears that installation of the neoprene gasket on the metal frame of the storm panel has been successful in combating condensation in Oklahoma's climate. Should condensation ever become a problem, the vent holes can always be added later.

The storm panels were installed by the crew floor by floor. The routed openings of the sash were measured and then float glass was cut in a basement workshop. Sections of extruded metal with an enamel coating were cut to the appropriate length and affixed to the glass with a hand crimping tool. The storm panels were then screwed into place (see figure 6). Because the storm panels were fabricated on the site, there was no need to keep a complicated inventory of window sizes, location, and so forth. There were also none of the problems associated with the transport and storage of such a large order.



**Figure 5.** Section through the window showing areas of weather stripping. Note that new weather stripping was also added between the sash and the wooden frame, or jamb.

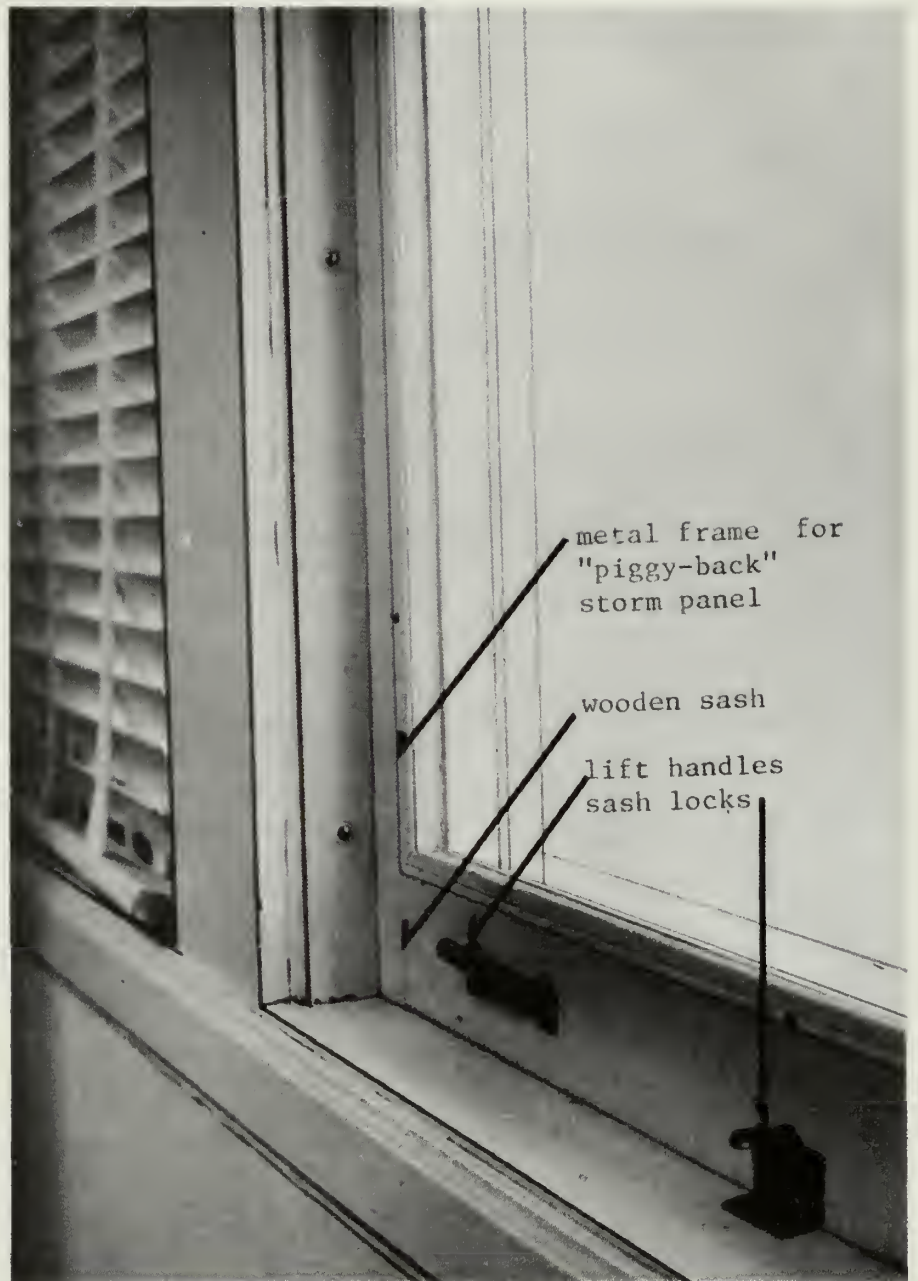

Figure 6. *New interior storm panel in place. Note that the storm panel was recessed into the wooden sash. This allows full operability of the window as the lower sash is raised without hinderance from the storm panel on the upper sash. The interior storm panels were affixed with screws and will be removed only for maintenance. (Photo: Tamara Coombs)*

## CONCLUSION

The use of the interior storm panels at the Colcord Building has been successful from the standpoint of energy efficiency, appearance, and cost. The original windows were saved, the historic character of the building remains, and the owner met his requirements for improved thermal efficiency. An unexpected benefit of retrofitting the windows was the final low cost of \$100 per window, which was a 66-percent savings over their original budget. In addition, as outlined in the following chart, the owners will continue to save money in the long run because the retrofitted window has a better *U*-value than the metal window. (The *U*-value refers to the coefficient of heat transmission of various materials). The architect has computed that with the combined benefits of low initial expense in retrofitting and decreased fuel bills associated with the retention of a wooden window, the owner should have a complete return on this aspect of his investment in 7 years.

Window Type	<i>U</i> -Value	Cost
Primary wooden sash with single glazing	1.00	\$0. - existing
Metal framed replacement window with double glazing, non thermal-break	.69	\$300
Primary wooden sash repaired with new interior storm panel	.49	\$20 - for repair and weather stripping  \$80 - for routing sash, storm panel fabrication and installation

CHART - *Thermal Efficiency and Costs for Alternative Windows, The Colcord Building.*

*Note that the U-Value is the coefficient of heat transmission of materials. The lower the number, the greater the insulating quality of the material. The best value, therefore, is the repaired wooden window with the new interior storm panel which cost \$100 per unit.*

Because the Colcord Building's window sash were in good condition, heavily constructed and of a simple one-over-one configuration, which eliminated the problem of routing muntins, a recessed interior storm panel was a practical solution. The approach used at the Colcord Building is an excellent example of retrofitting historic wooden windows to meet today's energy needs without destroying their integrity.



ADDITIONAL READING

ASHRAE Handbook - 1977 Fundamentals, New York:  
American Society of Heating, Refrigerating and Air-  
Conditioning Engineers, 1978 (chapter 26).

"Care and Repair of Window Sash." Old House Journal 4  
(no. 1, January 1976).

"Fixing Double-Hung Windows." Old House Journal 17  
(no. 12, December 1979)

"Inside Storm Windows." Old House Journal 5  
(no. 2, February 1977).

Myers, John H. "Preservation Briefs 9: The Repair  
of Historic Wooden Windows." Washington, D.C.: Technical  
Preservation Services, U.S. Department of the Interior,  
1980. Single copies available free from TPS.

National Bureau of Standards, Building Science Series 104.  
"Window Design Strategies to Conserve Energy."  
Washington, D.C. 1977. GPO stock no. 003-01794-9.

Smith, Baird M. "Preservation Briefs 3: Conserving  
Energy in Historic Buildings." Washington, D.C.  
Technical Preservation Services, U.S. Department of the  
Interior, 1978. Single copies available free from TPS.

"The Secretary of the Interior's Standards for Rehabilita-  
tion." Revised Edition. Washington, D.C.: Technical  
Preservation Services, U.S. Department of the Interior,  
1980. Single copies available free from TPS.

Owners of the  
Colcord Building :

The Colcord Associates  
Neal Horton, Partner  
The Colcord Building  
Oklahoma City, OK 73102

Construction Manager and  
General Contractor:

William L. McNatt  
3615 NW 44th Street  
Oklahoma City, OK 73112

Architects:

Jack Graves, AIA  
Architectural Design Group  
7400 N. Western Avenue  
Oklahoma City, OK 73116

Storm Window Subcontractor:

Architectural Glass  
P.O. Box 12284  
Oklahoma City, OK 73112

PRESERVATION CASE STUDIES

*The following publications are available and may be purchased from the Superintendent of Documents, U.S. Government Printing Office, Washington, D.C., 20402.*

The Morse-Libby Mansion, Portland, Maine: A Report on Restoration Work, 1973-1977. Morgan W. Phillips.  
Stock Number: 024-005-00699-1. \$2.40.

Fort Johnson, Amsterdam, New York: A Historic Structure Report, 1974-1975. Mendel-Mesick-Cohen.  
Stock Number: 024-005-00706-7. \$2.40

Carr Mill, Carrboro, North Carolina: A Rehabilitation Project under the Tax Reform Act of 1976.  
Stock Number: 024-016-00117-6. \$1.50.

Chateau Clare, Woonsocket, Rhode Island; Rodman Candleworks, New Bedford, Massachusetts: Rehabilitation Through Federal Assistance. Floy A. Brown.  
Stock Number: 024-016-00119-2. \$1.50.

Olmsted Park System, Jamaica Pond Boathouse, Jamaica Plain, Massachusetts: Planning for Preservation of the Boathouse Roof. Richard White.  
Stock Number: 024-016-00121-4. \$2.75.

Planning for Exterior Work on the First Parish Church, Portland, Maine, Using Photographs as Project Documentation. John C. Hecker, AIA.  
Stock Number: 024-016-00120-6. \$2.75.

Abbeville, South Carolina: Using Grant-In-Aid Funds for Rehabilitation Planning and Project Work in the Commercial Town Square. John M. Bryan and the Triad Architectural Associates.  
Stock Number: 024-016-00126-5. \$3.50.

Main Street Historic District, Van Buren, Arkansas: Using Grant-In-Aid Funds for Storefront Rehabilitation/Restoration Within a Districtwide Plan. Susan Guthrie.  
Stock Number: 024-016-00136-2. \$2.25.

Maymont Park - The Italian Garden, Richmond, Virginia: Using Grant-In-Aid Funds for Landscape Restoration. Barry W. Starke, ASLA.  
Stock Number: 024-016-00137-1. \$2.50.

Storefront Rehabilitation: The Harding Building, Jackson, Mississippi. Sharon C. Park, AIA.  
Stock Number: 024-016-00138-9. \$1.25.

Rehabilitating Historic Hotels: The Peabody Hotel, Memphis, Tennessee. Floy A. Brown.  
Stock Number: 024-016-00142-7. \$3.25.

Comment Form

Preservation Case Studies  
Improving Thermal Efficiency  
of Historic Wooden Windows:  
The Colcord Building, Oklahoma City, Oklahoma

Your comments and suggestions are most appreciated and may help us in future expanded publications on improving thermal efficiency in historic buildings. Please return this form to Technical Preservation Services, Preservation Assistance Division, National Park Service, U.S. Department of the Interior, Washington, D.C. 20240.

(Optional)

Name \_\_\_\_\_

Organization \_\_\_\_\_

Street \_\_\_\_\_

City \_\_\_\_\_

State/ZIP \_\_\_\_\_

fold

fold

fold

fold



No Postage  
Necessary  
If Mailed in  
the United States



Official Business  
Penalty for  
Private Use \$300

**Business Reply Mail**  
First Class Permit No. 12886 Washington D.C.

Postage will be paid by U.S. Department of the Interior

U.S. Department of the Interior  
National Park Service  
Preservation Assistance Division  
Washington, D.C. 20240



U.S. Department of the Interior  
National Park Service  
Washington, DC 20240

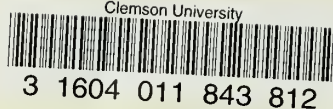

Postage and Fees Paid  
U.S. Department of the Interior  
INT. 417

