

I 29.9:Se5

Clemson University



3 1604 016 746 887

CLEMSON  
UNIVERSITY

# REMOTE SENSING

## A Handbook for Archeologists and Cultural Resource Managers



FEDERAL  
PUBLICATION



Digitized by the Internet Archive  
in 2013 with funding from  
LYRASIS Members and Sloan Foundation

<http://archive.org/details/remotesensinghan00lyon>

# REMOTE SENSING

## A Handbook for Archeologists and Cultural Resource Managers

**Thomas R. Lyons**  
**Thomas Eugene Avery**

**Cultural Resources Management Division**  
**National Park Service**  
**U.S. Department of the Interior**  
**Washington, D.C. 1977**

**Library of Congress Cataloging in Publication Data**

Lyons, Thomas R  
Remote sensing.

Bibliography: p.

Includes index.

I. Aerial photography in archaeology. 2. Photography in archaeology. I. Avery, Thomas Eugene, joint author.

II. Title.

CC76.4.L96            930'.1'028            77-608037

For sale by the Superintendent of Documents,  
U.S. Government Printing Office,  
Washington, DC 20402

Stock Number 024-005-00688-5

Contribution No. 4 of the Chaco Center,  
National Park Service and University of New Mexico.

# Foreword

A major responsibility of the National Park Service is the study, analysis, inventorying and monitoring of the historic and prehistoric record that men have left behind. Such cultural resources are found in virtually every different environmental setting in our country. The task is enormous. Modern tools are required to help the managers and interpreters of these resources do the job of protecting and preserving them for posterity and making them available to the interested visitor of today. Remote sensing technology provides one such tool and this Handbook and subsequent supplements provide managers and archeologists alike with the basic information needed to apply the techniques to their needs. The project is based upon six years of

applications research in the Chaco Canyon National Monument region of northwest New Mexico and in other National Park Service areas, and will consist of subsequent updates in the form of supplements on the regional application of remote sensing techniques.

It is a pleasure to present this series which is adapted from many scientific endeavors but is the first of its kind with a specific mission to study and manage many aspects of our cultural heritage.

Douglas H. Scovill  
*Chief Archeologist*  
*National Park Service*

Within the next five years, the National Park Service will publish several supplements to this handbook. They will include training and instrumentation supplements, a bibliography, and other publications dealing with regional applications of remote sensing for the archeologist and cultural resource manager. You may receive notification of these publications as they become available by writing the Superintendent of Documents, U. S. Government Printing Office, Washington, D.C. 20402. *Ask to be placed on mailing list N-557.*

# Introduction

To date, the great benefits of the space age technical developments are not where man has travelled and what he has seen in space, but rather the overview and grand perspective he has gained of his own planet, his home in space. These benefits have been derived primarily through the use of devices that sense electromagnetic energies of various types and intensities emanating from the surface of our globe. Geologists and geographers, agronomists and foresters, land-use and urban planners among others, have utilized pictorial and digital data from spacecraft and aircraft as tools in their studies. More recently, historians and archeologists, investigators of our cultural resources and heritage, have found that remote sensing provides many tools to aid them in their tasks of inventorying, evaluating, preserving, and monitoring the fragile physical remnants that represent man's past, his patterns of interreaction with others of his species, and with his environment.

The purpose of this Handbook, then, is to provide the cultural resource manager, the archeological and historical investigator, with the basic principles of remote sensor data gathering, handling, and interpretation. Further, it presents some explanation of the application of imaged and digital remote sensor data to problems of increasing magnitude and complexity which often can be resolved more rapidly with these techniques than by using only time honored and time consuming methods. It is intended as a guide for the manager and field investigator whose interest is human cultural history and development rather than a comprehensive explanation of the rapidly advancing discipline of remote sensing.

The book has been organized into several principal divisions. Sections I through IV set forth the basic characteristics and sources of aerial photography in order to give the reader the necessary background to understand its application to cultural resource problems. Section

V describes some simple and readily used mapping techniques that can be employed when more detailed photogrammetric maps are not required. Section VI discusses non-photographic sensors which record data that may be used in digital form or converted into graphic representations. It also introduces the reader to electronic laboratory equipment which isolates information inherent in digital or pictorial data but which is not readily found without mechanical aids. Sections VII and VIII deal with interpretation techniques with specific emphasis on man's modification of the natural environment. Section IX presents a basic explanation of photogrammetric mapping and its applications in cultural resource study and management. Finally, Section X summarizes procedures and parameters that must be considered in planning the acquisition of aerial imagery for archeological use.

Because the state-of-the-art in remote sensing technology is developing so rapidly, we felt it advisable to keep this handbook relatively basic, and in so doing, hopefully avoid the need for too frequent updating editions. To maintain currency in the field for the cultural historian and manager, we have initiated a series of supplements which can be revamped and reissued as changing conditions require. The first of this series of supplements consists of an instructional supplement containing exercises tied to the text to familiarize the novice interpreter with problems relevant to his professional goals. The second supplement is a review of current remote sensor instruments and a discussion of their use and application in cultural studies. These two volumes are to be followed with physiographic supplements in which various techniques are identified and discussed as they apply to the different environmental zones in the United States.

T.R.L.  
T.E.A.

# Contents

Section 1	Introduction to Aerial Photography	1
	Types of Aerial Photographs	1
	Camera Platforms	2
	Image Resolution and Area Coverage	4
	Spectral Sensitivity of Films	5
	Panchromatic Film	5
	Black and White Infrared Film	6
	Normal Color Film	6
	Infrared Color Film	6
Section 2	Object Identification and Stereoscopy	8
	The Interpretation Task	8
	Key Photo Interpretation Factors	8
	Monocular Vision	9
	Binocular Vision	11
	Types of Stereoscopes	11
	Photo Orientation for Stereo-Viewing	11
	Preparation of Stereograms	13
Section 3	Photo Scale, Displacement, Areas, and Parallax	14
	Scale Determinations	14
	Focal Length/Altitude Method	14
	Photo/Ground Distance Method	14
	Quick Laboratory Checks of Photo Scale	16
	Photo Image Displacement	16
	Relief Displacement	18
	Measuring Areas	20
	Planimeters and Dot Grids	21
	The Parallax Formula	22
	The Parallax Wedge	22
	The Parallax Bar or Stereometer	22
	Precision of Height Measurements	24
Section 4	Sources of Existing Imagery and Maps	27
	Introduction	27
	Photography from U.S. Government Agencies	27
	Local Photographic Coverage	28
	Satellite and High-Altitude Imagery	30
	Imagery from the Canadian Government	30
	Photography from Commercial Firms	30
	Taking Your Own Photographs	30
	Topographic Maps	31

Section 5	Simple Mapping Techniques	32
	Photographs as Map Substitutes	32
	Mosaics as Map Substitutes	32
	Existing Base Maps	33
	Use of Map Projections	33
	Mapping by Radial Line Plots	33
	Photo Annotation and Delineation	35
	Monocular Transfer of Photo Annotations	36
	Stereoscopic Transfer of Photo Annotations	36
	Form-Line Sketching	38
	Topographic Map Compilation	38
Section 6	Nonphotographic Sensors, Field and Laboratory Equipment	40
	Introduction	40
	Nonimaging Sensors	40
	Imaging Sensors	40
	Field Aids for Photointerpretation	43
	Electronic Aids to Image Analysis	44
Section 7	General Interpretive Techniques	48
	What is Interpretation?	49
	Physical Attributes	49
	Mental Attributes	49
	Knowledge and Association	51
	Interpretation Training	51
	Interpretation Keys	51
Section 8	Archeological Interpretation of Remote Sensor Data	53
	Introduction	53
	Interpretation Skills	53
	Field Methods of Remote Sensing Site Survey	54
	An Approach to Site Discovery	59
	Site Detection from Plant Marks	59
	Site Detection from Soil Marks	61
	Site Detection from Shadow Patterns	61
	Other Methods in Archeological Remote Sensing Interpretation	62
	Remote Sensing in Cultural Resource Management	64
	Summary	65
Section 9	Photogrammetric Methods in Archeology	68
	Introduction	68
	Definition	68
	General Uses of Photogrammetry	70
	Archeological Applications of Photogrammetry	81
Section 10	Generalized Specifications for Archeological Photography	84
	Introduction	84
	Season of Photography	84
	Time of Day	84
	Photographic Scale	86
	Type of Film	86
	Cost Factors	86
	Inspection of Contract Photography	87



References	Photogrammetry, Photo Interpretation, and Archeological Applications	90
	Historical Geography and Archeology	91
Glossary		95
Index		105

## Figures

- |     |   |    |     |  |    |
|-----|---|----|-----|--|----|
| 1-1 | Stereogram of Second Canyon Ruin, Pima County, Arizona  | 2  | 3-7 | Parallax wedge oriented over a stereogram of a recently logged area  | 23 |
| 1-2 | Combined vertical stereogram and ground view of the Wijiji ruins, Chaco Canyon National Monument, New Mexico              | 3  | 3-8 | Mirror stereoscope with an attached parallax bar for measuring heights of objects                                      | 23 |
| 1-3 | Ground stereo-photography in a grove of redwood trees   | 4  | 4-1 | Section of an aerial photo index sheet covering a portion of the Kaibab National Forest, Coconino County, Arizona      | 29 |
| 1-4 | Ground coverage as a function of altitude   | 5  | 5-1 | An orthophotograph with superimposed topographic contours of Chaco Canyon National Monument, New Mexico                | 34 |
| 1-5 | Photographic portion of the electromagnetic spectrum  | 5  | 5-2 | Schematic diagram of paper prints and assembly into radial line plots  | 35 |
| 1-6 | Hypothetical spectral reflectance curves for deciduous versus coniferous tree foliage                                     | 5  | 5-3 | A zoom transfer scope  | 37 |
| 2-1 | Four image characteristics that aid in object identification  | 9  | 5-4 | The <i>Stereopret</i> , a stereoscopic viewing and map transfer device   | 37 |
| 2-2 | Cut-out views from 12 vertical photographs taken in the eastern United States   | 10 | 5-5 | The Kern PG-2 plotter  | 39 |
| 2-3 | Tandem arrangement of two Old Delft scanning stereoscopes over a light table  | 12 | 6-1 | An active radar apparatus mounted on a hand-drawn cart   | 41 |
| 2-4 | Magnifying "zoom-type" stereoscope  | 12 | 6-2 | The electromagnetic spectrum   | 41 |
| 2-5 | A three-step procedure for aligning and overlapping 9 by 9 in. aerial photographs for study with a lens stereoscope       | 13 | 6-3 | An annotated thermal infrared aerial image of the Kin Bineola ruins area in Chaco Canyon National Monument, New Mexico | 42 |
| 3-1 | Relationship of camera focal length and height above ground (or mean sea level) to photo scale                            | 15 | 6-4 | A multispectral scanner (MSS) four-channel image from LANDSAT spacecraft   | 43 |
| 3-2 | Application of photo distance (PD) and ground distance in determining photo scale   | 15 | 6-5 | Portable kit for interpretation of aerial photographs in the field   | 44 |
| 3-3 | The principal point of a photograph   | 16 | 6-6 | A multiadditive viewer for analysis of multiband imagery   | 45 |
| 3-4 | Displacement patterns of points below and above the datum plane of an aerial photograph                                   | 18 | 6-7 | A four lens aerial multiband camera  | 45 |
| 3-5 | Stereogram of precipitous terrain in Yosemite National Park, California   | 19 | 6-8 | A closed circuit television system with several image analysis capabilities  | 46 |
| 3-6 | Dot grid with 16 dots per sq. in. oriented over a photograph taken at a scale of 600 ft. per in., or 10 acres per sq. in. | 21 | 6-9 | Schematic drawing of the integrated closed circuit television system   | 47 |
|     |   |    | 7-1 | A ball court identified as such by an archeologist through the process of association                                  | 48 |
|     |   |    | 7-2 | A stereoscopic perception test   | 50 |

- 7-3 The changes in land features brought on by urban expansion are demonstrated in this aerial photograph of Monroe County, New York 50
- 7-4 An archeologist using an aerial photograph in the conduct of field examinations 52
- 8-1 A section of a photogrammetric manuscript map of the Pueblo Alto site, Chaco Canyon National Monument, before excavation 55
- 8-2 A section of a photogrammetric map of the Kin Bineola area, Chaco Canyon National Monument, with archeological and natural anomalies identified 56
- 8-3 A vertical black and white aerial photograph of Kin Ya'a Ruin, Chaco Canyon National Monument, with prehistoric roadways identified 57
- 8-4 The same field as that pictured in Plate 4 as seen on a black and white TV monitor (above) and an edge-enhancer monitor (below) 58
- 8-5 Schematic diagram of positive crop marks (left) and negative crop marks (right) 60
- 8-6 Terrain profile (above) showing how soil marks are produced, with a vertical view of similar terrain (below) 60
- 8-7 Terrain profile (above) showing how shadow marks result from a low sun angle, with a vertical view of similar terrain (below) 60
- 8-8 A vertical aerial photograph of the beach terraces of ancient Lake Estancia in central New Mexico 63
- 8-9 A suggested procedure in archeological remote sensing 66
- 8-10 Remote sensor systems used in archeological and related investigations 67
- 9-1 A terrestrial photogrammetric drawing of Mummy Cave Ruin, Canyon del Muerto, Arizona 69
- 9-2 An example of a "neat" stereo model 72
- 9-3 Types of plastic panel layouts used to premark horizontal and vertical ground control points 81
- 9-4 An aerial photographic flight line prepared for control extension or bridging and illustrating the location of horizontal and vertical ground points 81
- 9-5 A computer plot, using digitized horizontal and vertical photogrammetric data, of the Kin Bineola ruin in Chaco Canyon National Monument 83
- 10-1 Imagery inspection check list 88

## Color Plates

- 1 A color infrared photograph of a portion of Chaco Canyon National Monument 73
- 2 Portion of topographic map and aerial photograph of Fort Smith, Arkansas 74
- 3 Portion of a USGS topographic map (scale of 1:24,000) based on a polyconic projection 75
- 4 A prehistoric agricultural field, transected by a modern road, as it appears on a density analyzer 76
- 5 An aerial view of Wijiji ruin in Chaco Canyon National Monument in which vegetation patterns point to the structure's being built on an old stream channel 77
- 6 A portion of a U.S. Geological Survey topographic map of San Juan County, New Mexico showing the location of some prehistoric roadways 78
- 7 Ecological variations in Chaco Canyon National Monument as distinguished by the various color bands displayed on the TV monitor of a density analyzer 79
- 8 A vegetation thematic map of an area near Tampa Bay, Florida in which eight distinct biomes were identified and mapped from ERTS imagery 80

## Tables

- 3-1 Scale conversions for vertical aerial photographs 17
- 3-2 Effect of topographic changes on area equivalents for 1:12,000 aerial photographs 20
- 3-3 Parallax-wedge conversion factors for wedges reading 0.002-inch parallax (dP) 24
- 3-4 Parallax-bar conversion factors for devices reading 0.01-mm. parallax (dP) 25-26
- 4-1 Approximate number of exposures required for stereoscopic coverage, by size of area and scale 28
- 4-2 Scales of national topographic maps available from the U.S. Geological Survey 31
- 9-1 Methods of determining necessary aerial photo scale and horizontal ground control for desired map scale 71
- 10-1 Average number of days suitable for aerial photography, by state and month of year 85
- 10-2 Conversion ratios for determining the average scale of aerial photographs 89

## Introduction to Aerial Photography

Remote sensing may be defined as the detection, recognition, or evaluation of objects by means of distant recording devices. An astronomical telescope, an aerial camera in a supersonic jet aircraft, or a sonar installation in a submarine are all forms of remote sensors. The nocturnal bat employs an acoustical remote-sensing technique to guide its flight in darkness; a similar principle is embodied in radar equipment.

In this manual, emphasis is on the use of aerial and terrestrial photography as the principal form of remote-sensor imagery. However, some attention is also given to non-photographic sensors such as thermal scanners, side-looking airborne radar, and multispectral scanners. Other forms of imagery and data processing techniques are discussed in various supplements to this volume.

Remote sensor imagery is a vital tool of archeologists, historical geographers, and others who are concerned with the discovery, evaluation, and preservation of historic or prehistoric cultures and environments. Although many such sites are still being discovered by accident, aerial imagery provides a systematic means of searching out features that may have gone unnoticed for centuries (fig. 1-1). Furthermore, the remote sensor imagery itself constitutes historical data. Once acquired, it becomes a historical document of conditions that existed at a certain point in time and space.

### Types of Aerial Photographs

**Vertical photographs** are taken with the camera axis held in a vertical or near-vertical position;

i.e., perpendicular to the surface of the earth. Any inclination of the camera axis from a truly vertical orientation will result in a *tilted* or *oblique* photograph. Overlapping exposures in each flight line permit an interpreter to study vertical photographs three-dimensionally with a stereoscope. Because such prints have become so useful for mapping and interpretation, the term "aerial photo" is normally assumed to denote a vertical photograph and will be thus applied in this manual (fig. 1-2).

**Oblique photographs** are taken with the camera axis intentionally inclined from the vertical. One that contains the apparent horizon of the earth is termed a high oblique. One that does not contain the apparent horizon is called a low oblique. An oblique photograph covers a larger area compared with a vertical photograph from the same altitude, but its usefulness may be limited to fairly level terrain where the view is not obstructed by ridges. For this reason, and because obliques do not readily lend themselves to stereoscopic viewing, they are seldom used by archeologists in the United States.

**Composite photography** is accomplished either by several cameras taking simultaneous pictures, or by one camera having several lenses to provide multiple exposures.

**Mosaics** are composite pictures assembled from vertical aerial photographs. Individual photographs are cut, matched, and pasted together to give the appearance of a single, large print. A mosaic assembled by reference to known points on the ground is called a controlled mosaic; if ground control of linear distances is lacking, the

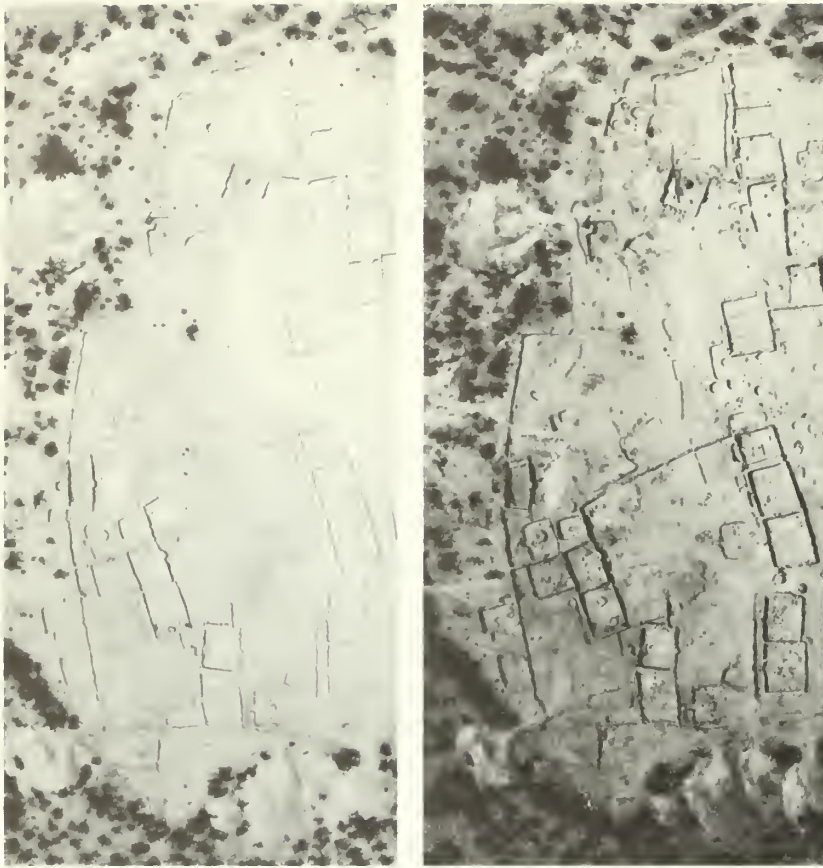

1-1 Stereogram of Second Canyon Ruin, Pima County, Arizona, discovered in 1969. Scale is about 433 ft/in. Courtesy Arizona Department of Transportation and Arizona State Museum.

mosaic is called uncontrolled. When carefully assembled, both types provide good map approximations. Mosaics are often used as pictorial displays in offices and public buildings. Professionally prepared mosaics are expensive and cannot be studied three-dimensionally. However, they can be used by archeologists for plotting site locations, for settlement pattern analysis, and for vegetative zone studies.

**Terrestrial photographs** are those pictures taken from the ground or from ground-anchored camera platforms. Included here are horizontal, oblique and vertical photographs, either as single views or in the form of stereoscopic pairs of images (fig. 1-3).

## Camera Platforms

A large proportion of the photographs used by archeologists are pictures taken from conventional, fixed-wing aircraft. However, suitable exposures can also be obtained from earth-orbiting spacecraft, from helicopters, and from ground-based or ground-anchored platforms.

Where existing imagery is relied upon, space-craft or conventional aircraft pictures will constitute the bulk of available photography. Low-altitude site photographs are ordinarily the result of "do-it-yourself projects" or special coverage by aerial survey firms. The combination of camera platforms currently in use can

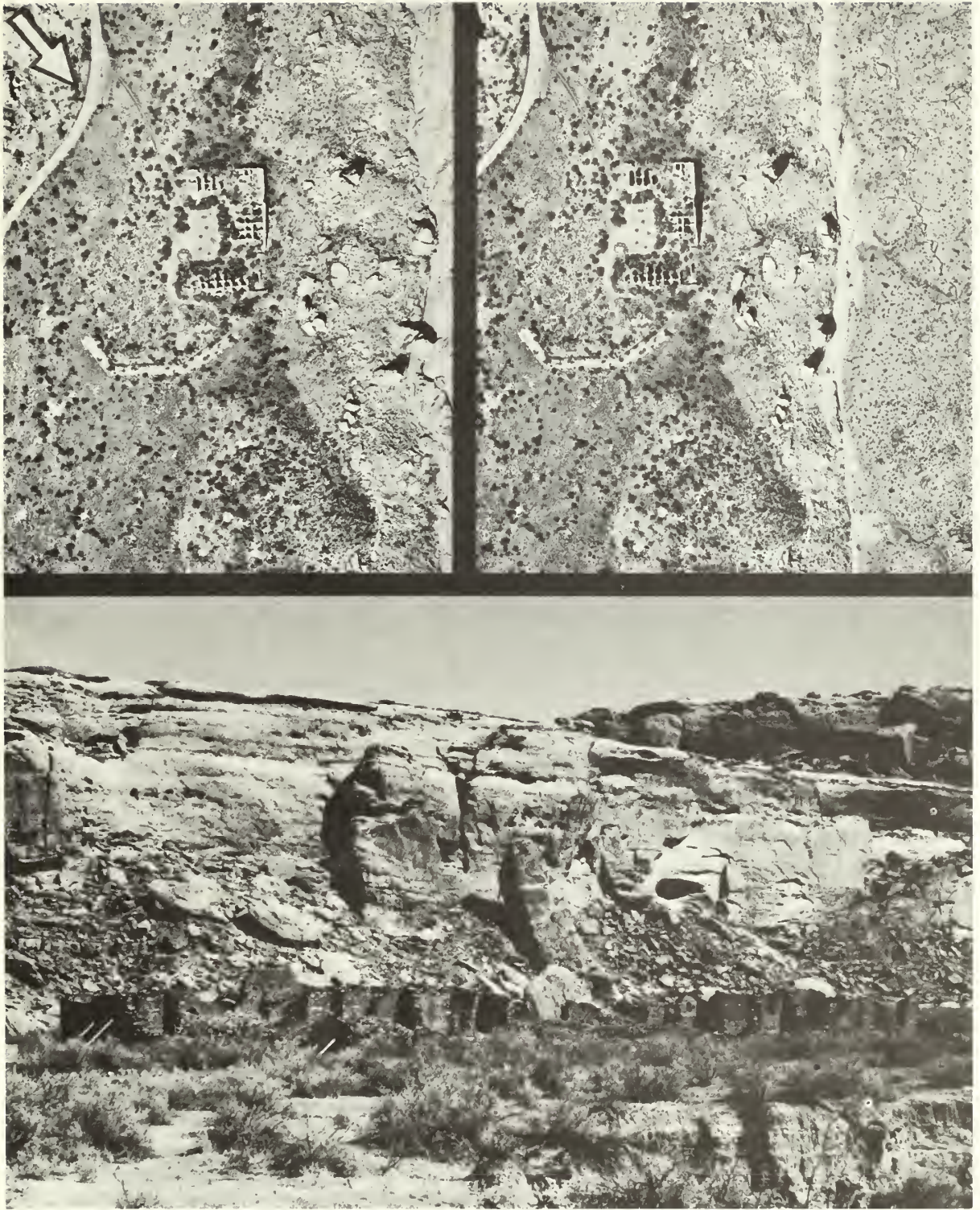

1-2 Combined vertical stereogram and ground view of the Puebloan ruin Wijiji in Chaco Canyon National Monument. The arrow indicates the orientation of the ground level view. Scale of vertical stereogram is about 250 ft. per in.



1-3 Ground stereo-photography in a grove of redwood trees. The views were taken simultaneously with paired reflex cameras having a dual cable release. Photo by T. E. Avery.

result in image scales that range from 1:1,000,000 down to 1:100 or larger.

Extremely large-scale imagery is commonly obtained by using ground-controlled camera platforms such as tripods, bipods, or captive balloons. For smaller sites and "spot" excavations, the ground-based tripod or bipod platform works well for sequential or phase photography. Regular hand-held cameras or aerial cameras that use 70-mm film can be rigged for obtaining vertical photographs—either as single exposures or in stereoscopic pairs. When the selected cameras are manually operated, access to the camera platform is needed to advance and change the film and possibly to cock and release the shutter. Therefore, such setups prove most efficient when the camera height above the site is less than 30 ft.

For larger sites and where the camera must be suspended 50 to 1,000 ft above ground, tethered balloons can be used in conjunction with remotely controlled cameras for phase photography. Sequential exposures obtained at various levels of excavation provide permanent records for the study at successive periods of occupation.

## Image Resolution and Area Coverage

Once the objectives of a particular aerial survey have been clearly defined, the choice of an image scale will be dependent on allowable expenditures, minimum ground resolution requirements, and desired area coverage per frame. As a rule, optical imagery provides superior ground resolution to other types of remote-sensor imagery.

Photographic resolution may be defined as the capability of an entire photographic system (lens, film, processing, etc.) to render a defined image. Resolution is expressed in terms of lines per millimetre recorded by a given film under specified conditions. The resolution capability of the camera lens itself is termed the lens *resolving power*; this value is also expressed as the maximum number of lines per millimetre that can be seen as separate lines (i.e., resolved) in the image.

The ground area covered by a given exposure or "frame" is a function of the negative format size, the camera focal length, and the

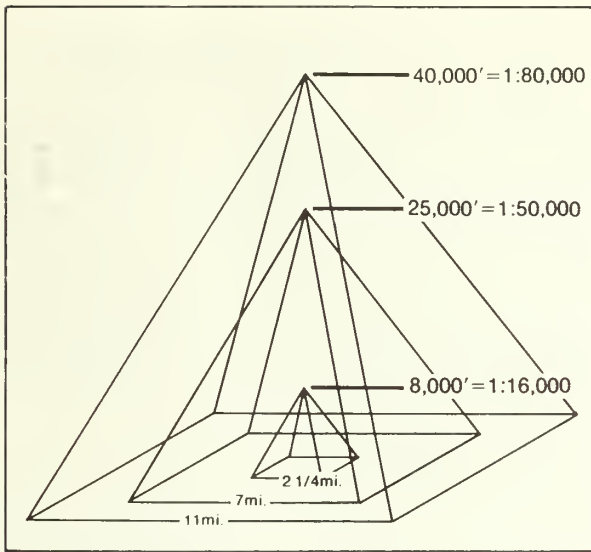

1-4

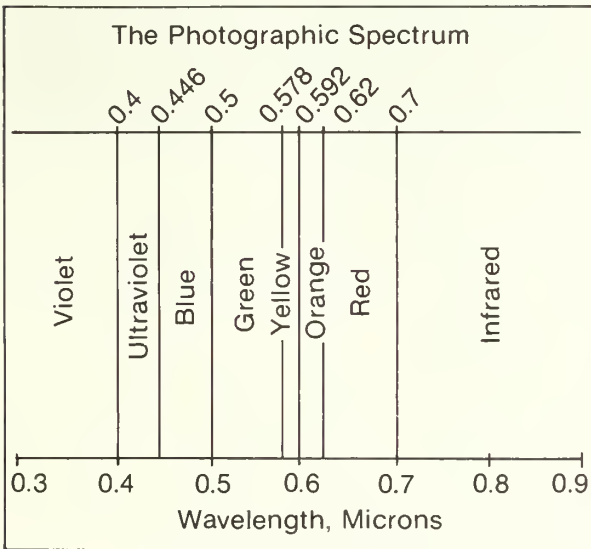

1-5  
1-6

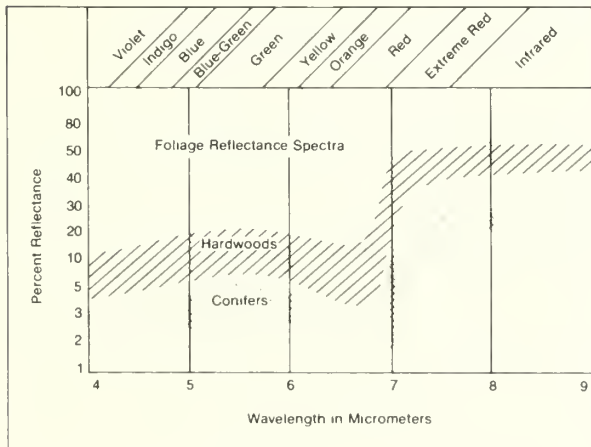

1-4 Ground coverage as a function of altitude. A six-inch camera focal length is assumed. Courtesy U.S. Army Engineer School, Ft. Belvoir, Virginia.

1-5 Photographic portion of the electromagnetic spectrum.

1-6 Hypothetical spectral reflectance curves for deciduous versus coniferous tree foliage. To assure tonal separation of these foliage types on aerial photographs, the film selected should have a high degree of sensitivity in the range of 0.7 to 0.9 micrometers.

flight altitude above ground. As an illustration, Figure 1-4 was prepared to illustrate ground coverage for a 9 by 9-in. negative format at three different altitudes above ground.

## Spectral Sensitivity of Films

Image quality and photographic tone (or color) are dependent on the spectral reflectance of objects photographed and the sensitivity of film emulsions to varying wavelengths of reflected light. Light wavelengths are measured in micrometers; that portion of the electromagnetic spectrum visible to the human eye encompasses wavelengths of about 0.4 to 0.7 micrometers (fig. 1-5). Available films may be sensitized to a slightly wider or narrower span of wavelengths; with appropriate filtration, these emulsions can produce a large variety of tonal contrasts on the resulting exposures.

If one wishes to discriminate between environmental features having different reflectance characteristics, it is often possible to select a film (in advance) that will produce the desired result (fig. 1-6). Archeologists ordinarily rely on two types of black-and-white film, panchromatic and infrared, and two kinds of color films, normal color and infrared color (see Plate 1).

## Panchromatic Film

Panchromatic films have about the same range of light sensitivity as the human eye. They are regarded as the "standard" films for aerial mapping, charting, and general aerial photography. Pan film, as panchromatic materials are

called, has relatively high sensitivity in the red portion of the spectrum, thus permitting fast shutter speeds through haze-cutting filters.

Images on panchromatic film are rendered in varying shades of gray, with each tone comparable to the density of an object's color as seen by the human eye. Panchromatic-sensitive film is a superior black-and-white film for distinguishing objects of truly different colors; it is recommended for such projects as highway route surveys, urban planning, archeological mapping, and locating property ownership boundaries. Since old roads and trails are easily seen, panchromatic prints are also useful as field maps for the archeological surveyor or land manager who must find his way through unfamiliar terrain.

Since panchromatic film is only moderately sensitive to the green portion of the spectrum, most healthy vegetation appears in similar gray tones on the prints. Where only coniferous (needleleaf) trees are present, panchromatic film may be preferred for the classification of forest vegetation. On the other hand, if deciduous (broadleaf) vegetation is interspersed with coniferous trees, separation of the different types can be more easily accomplished by using black-and-white infrared film.

## Black and White Infrared Film

This high-contrast film sensitive to infrared radiation as well as to the blue, green, and red portions of the visible spectrum, is especially suited for applications in archeological exploration, forestry, hydrology, and geology. It is sometimes exposed through red or dark-red filters; thus, exposures can be made for red and infrared wavelengths only. Such photography is often described as "near-infrared," because most exposures utilize only a small band of infrared radiation ranging from about 0.7 to 0.9 micrometres.

Gray tones on infrared film apparently result from the degree of infrared reflection of objects rather than from their true colors. For example, broadleaf vegetation is highly reflective, and therefore photographs in light tones of gray; coniferous or needleleaf vegetation tends to be less reflective in the near-infrared portion of the spectrum, and consequently registers in much

darker tones. This characteristic makes infrared film the preferred black-and-white material for delineating timber types in mixed forests.

Bodies of water absorb infrared light to a high degree, and thus register quite dark on the film unless heavily silt-laden. This rendition is useful for determining the extent of river tributaries, canals, tidal marshes, swamps, and shorelines. Infrared materials are superior to panchromatic materials for penetration of haze. When the film is exposed through yellow filters, the resulting compromise in contrast is sometimes referred to as "modified infrared."

## Normal Color Film

This is a daylight-exposure film that is sensitized to all visible colors; it provides transparencies with natural color rendition when properly exposed and processed. The emulsion has proven especially valuable for identifying soil types, rock outcrops, and industrial stockpiles. Normal color can also penetrate water well, and it is therefore useful for subsurface exploration, hydrographic control, and the delineation of shoreline features. As is the case with most color films, correct exposures require conditions of bright sunlight.

Color films are processed to produce positive color transparencies rather than ordinary paper prints. In many instances, conventional color photographs are superior to black-and-white pictures for studies of natural vegetation, because the human eye can distinguish many more color variations than gray tones.

## Infrared Color Film

Infrared color is a false-color film that differs from normal color in that the three emulsion layers are sensitized to green, red, and infrared radiation instead of the usual blue, green, and red wavelengths. When the film is correctly exposed, the resulting transparencies display colors that are false for most natural features. The film was originally designed to emphasize differences in infrared reflectance between live, healthy vegetation and visually similar objects camouflaged with infrared-absorbing green paints.



Infrared color film has proven especially valuable for a variety of forest-survey projects such as the early detection of disease and insect outbreaks in timber stands, and in archeology for detecting soil and vegetation patterns disturbed by human activity. Basic to such application is the identification of tree species or forest cover types, a task that requires information on the infrared reflectivity of various types of foliage. Since healthy broadleaf trees have a higher infrared reflectivity than healthy needleleaf trees, their photographic images can usually be separated on these kinds of exposures.

It must be obvious to the reader that no single film emulsion serves all purposes. Instead, the varied tones and patterns produced by differing ranges of film sensitivity complement each other, and the maximum amount of information can be extracted only when several types of imagery covering the same area are studied simultaneously. Photographic coverage representing two or more regions of the electromagnetic spectrum is known as multispectral sensing.

## Section 2

# Object Identification and Stereoscopy

### The Interpretation Task

Photo interpretation may be defined as the art of identifying objects on aerial photographs and determining the meaning or significance of these objects. Photogrammetry, the science of deriving measurements of features from their photographic images, is also of importance in the interpretation process. A good photointerpreter is one who successfully combines a sound subject matter background with an above-average ability to observe, recognize, and draw meaningful inferences from various patterns and tones that are imaged on aerial photographs. It is evident that the thought processes involved here make photographic interpretation both an art and a science.

An aerial photograph depicts much more information about an area than a map covering the same terrain (Plate 2). Almost all landscape features are registered on an aerial image; this can mean a clutter of too much detail, or the obscuring of important cultural features by vegetation or long shadows. The patterns caused by man and nature can be confusing, unless the interpreter understands the key principles of image interpretation.

### Key Photo Interpretation Factors

The following key image characteristics are considered, consciously or subconsciously, in the identification of objects on aerial photographs.

**Size:** Both relative and absolute sizes of objects are important. Comparison of the various sizes of buildings in a given area, in relation to their surroundings, aids in determining probable usage. Commercial and industrial areas tend to contain large buildings in close proximity. Small buildings with more room around them mark the usual pattern of residential areas, villages, and many prehistoric communities. It must be remembered that size is a function of the photographic scale (fig. 2-1).

**Shape:** Many objects possess characteristic shapes that help to identify the features. Man-made features appear as straight or smooth curved lines, while natural features usually appear to be irregular. Some of the most prominent manmade features are highways, railroads, bridges, canals and buildings. Contrast the regular shapes of these to the irregular shapes of such natural features as streams, rock outcrops, soil patterns and timber stands.

**Shadow:** All objects in relief will cast shadows when there is a directional source of light. By studying the shadows of an object, much can be learned about the overall shape. For example, different species of trees, or the profile of a building may be identified from characteristic shapes of their shadows.

In analyzing cultural features, the general type of construction may be "read" from object shadows. For example, the number of spans, cable suspensions and/or abutments are often reflected by the shadow of a bridge.

**Surrounding objects (topographic location):** Rela-

tive elevation, including drainage features, can be an important clue in predicting soil conditions, or the probability of encountering a particular plant community. The existence of archeological sites is often predicted by knowing the topographical conditions in which they occur.

**Texture:** The degree of coarseness or smoothness exhibited can be useful in the identification of images. Texture is directly related to photo scale. For example, the texture of a corn field on a small-scale photo may appear the same as the texture of a grass meadow on a large-scale photograph.

**Pattern:** If the arrangement of trees in an orchard is compared with that of natural vegetation, a contrast in patterns will be evident. The time of year that the photograph was taken may have some effect on image patterns. Prehistoric roads, ruins and fields frequently are recognized by the distinctive patterns they leave behind.

2-1 Four image characteristics that aid in object identification. Source: U.S. Army Engineer School, Ft. Belvoir, Virginia.

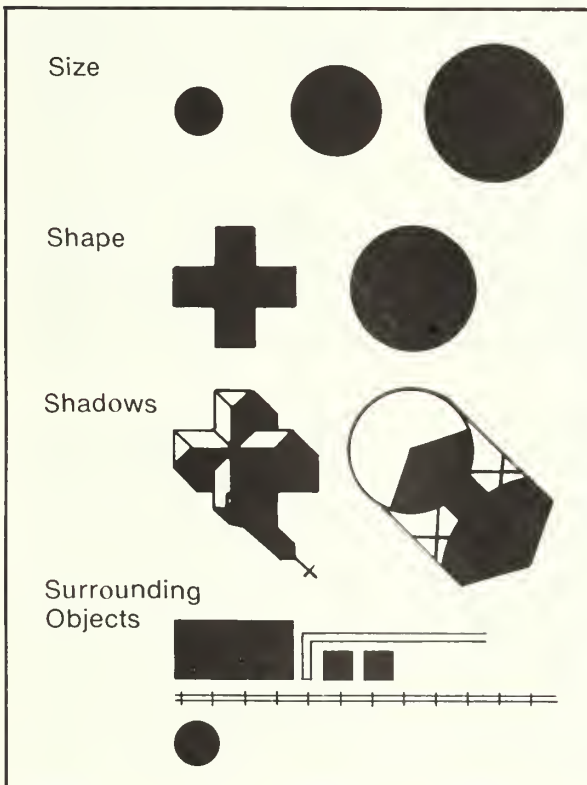

**Tone:** Objects of different color and texture have different qualities of light reflectance and therefore register in varying shades or tones on a photograph. Tonal values may aid in the discrimination of objects. As an example, smooth paved roads, especially those constructed of concrete, show as light bands on photos. Dirt and rough-surfaced roads often appear much darker in tone. The ballast between railroad ties shows a sharp tonal contrast to the metal rails on large-scale photos. Airstrips and surfaced parking areas reflect light and, consequently, are much lighter in tone than the darker ground that surrounds them.

Many of the image characteristics that have been described can be seen in figure 2-2. Principal modern features that are evident on these large-scale photographs are:

1. Orchard, cultivated fields, woodlands, roads
2. Contour plowing, farm buildings, pond, deciduous trees
3. Farm pond with earth dam, fields, woodland
4. Oil storage tanks, docks, rail lines, conveyors
5. Fenced race track, grandstand, woodlands
6. Grain elevators, warehouse, rail lines, barges in river
7. Golf course, showing greens, fairways, and sand traps
8. Drive-in theatre
9. Baseball park, showing grandstand and scoreboard (left field)
10. Residential housing
11. Shopping center with parked cars
12. Highway cloverleaf; snow on ground

## Monocular Vision

In the preceding examples, many objects were identified from simple, vertical photographs. However, the main drawback to such interpretation is that only two dimensions are clearly perceived—length and width.

When an object is viewed with a single eye, its distance from the observer can be judged only with difficulty. Using a single photograph is, in effect, seeing with a single eye. Objects on the photograph appear familiar and are recogniz-

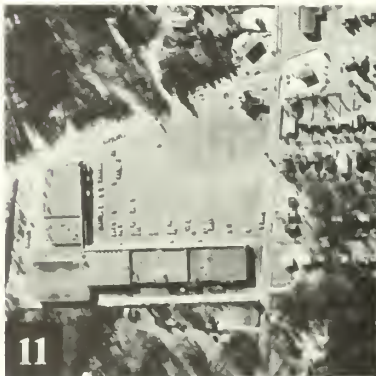
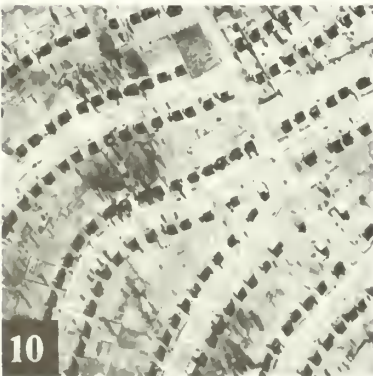
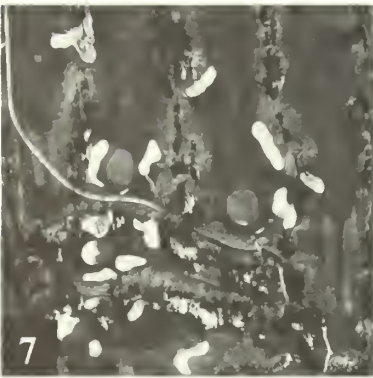
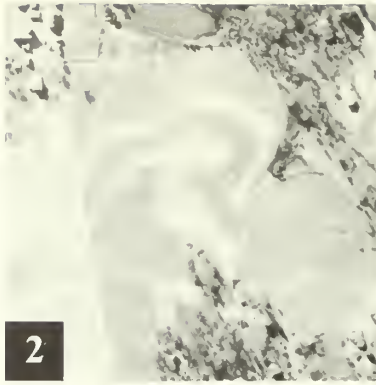

2-2 Cut-out views from 12 vertical photographs taken in the eastern United States. Courtesy Abrams Aerial Survey Corp.

able because of their shape, tone, relative size, arrangement, and shadow pattern. In many cases an idea of topographic forms may be perceived, but depth perception is nonexistent by comparison to that achieved with stereoscopic vision.

## Binocular Vision

Stereovision, or binocular vision, is the nearly universal ability to see depth, or relief with the human eyes. When an object is photographed from *two different points in space*, the dual images that result can be viewed three-dimensionally with a simple and inexpensive stereoscope. The two photographic images, consisting of a left-hand and a right-hand view, are arranged under corresponding lenses of the stereoscope; the instrument “forces” the left eye to look only at the left-hand photograph, while the right eye sees only the right-hand view. The result is a somewhat vertically exaggerated three-dimensional image.

With aerial photography, stereoscopic coverage is achieved by having adjacent exposures in each flight line overlap by 55 to 65 percent. Any two overlapping photographs thus constitute a stereo-pair or model that can be viewed three-dimensionally with a simple stereoscope.

## Types of Stereoscopes

Instruments employed for the three-dimensional study of aerial photographs are of three general types: lens stereoscopes, mirror or reflecting stereoscopes, and zoom-type, magnifying stereoscopes.

With a simple lens or pocket stereoscope, normal line of sight convergence is overcome by lengthening the focal length of the eyes. If an ordinary magnifying lens is placed at a distance equal to, or slightly less than its focal length, the object observed will be at or near optical infinity from the eyes. The line of sight will be parallel, or nearly so, and stereoscopic vision is obtained by correctly placing one of a stereoscopic pair under each lens. The main disadvantage of the lens stereoscope is that only a portion of a standard (9 by 9 in.) print overlap can be viewed at one time.

By use of prisms and/or mirror systems, reflecting stereoscopes provide an unmagnified stereoscopic view of an entire print overlap. If magnifying binoculars are added, however, the field of view may be somewhat reduced. One type of reflecting stereoscope is shown in figure 2-3.

Magnifying stereoscopes of the “zoom” type are office or console-mounted instruments that can be used to study uncut rolls of aerial negatives or positive transparencies. Such stereoscopes may feature both variable magnification and a capability of 360-degree optical image rotation within each optical system (fig. 2-4).

## Photo Orientation for Stereo-Viewing

The method for orienting vertical stereopairs for use under a stereoscope may be described in three steps (fig. 2-5).

**Step 1:** Select adjacent overlapping prints. Each vertical photograph of a properly taken stereo-pair overlaps the next by about 60 percent. Orient the stereopair so that both photo numbers are on the same side and the shadows fall *toward the viewer* of the stereo pair.

**Step 2:** Overlap the photos so that the detail is continuous. Note the exact alignment of print edges; non-perfect alignments are due to the presence of crab or drift in the flight line.

**Step 3:** Pull the two photos apart about 2.2 in., so that the overlapped portions are visible, side by side. Be certain to maintain the same alignment of print edges as determined by Step 2. Careful adherence to this procedure will avoid a pseudoscopic effect that can result when left-hand and right-hand images are transposed.

With corresponding photo images separated about 2.2 in., the lens stereoscope is adjusted to the interpupillary distance of the observer, usually about 2.3 to 2.5 in. Then the stereoscope is placed over the prints with its long axis parallel to the overlap, i.e., with lenses over paired photographic images. In this way, an overlapping strip 2.2 in. wide and 9 in. long can be viewed

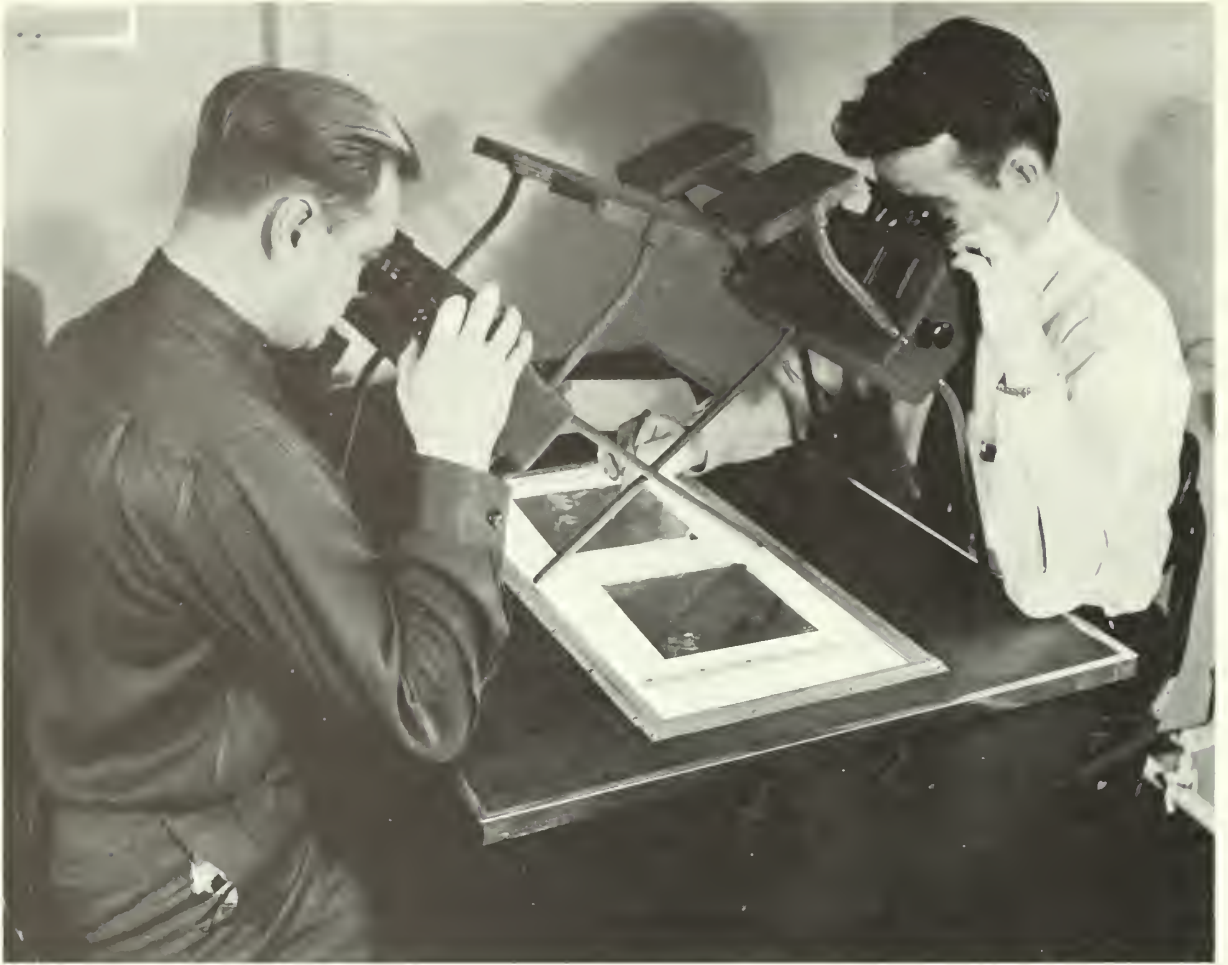

2-3

2-4



2-3 Tandem arrangement of two Old Delft scanning stereoscopes over a light table. Such setups permit both interpreters to study the same stereoscopic image simultaneously. Courtesy US Forest Service Remote Sensing Project, Berkeley, California.

2-4 Magnifying "zoom-type" stereoscope. Courtesy Bausch and Lomb, Inc.

2-5 A three-step procedure for aligning and overlapping 9- by 9-in. aerial photographs for study with a lens stereoscope. Courtesy U. S. Army Engineer School, Ft. Belvoir, Virginia.

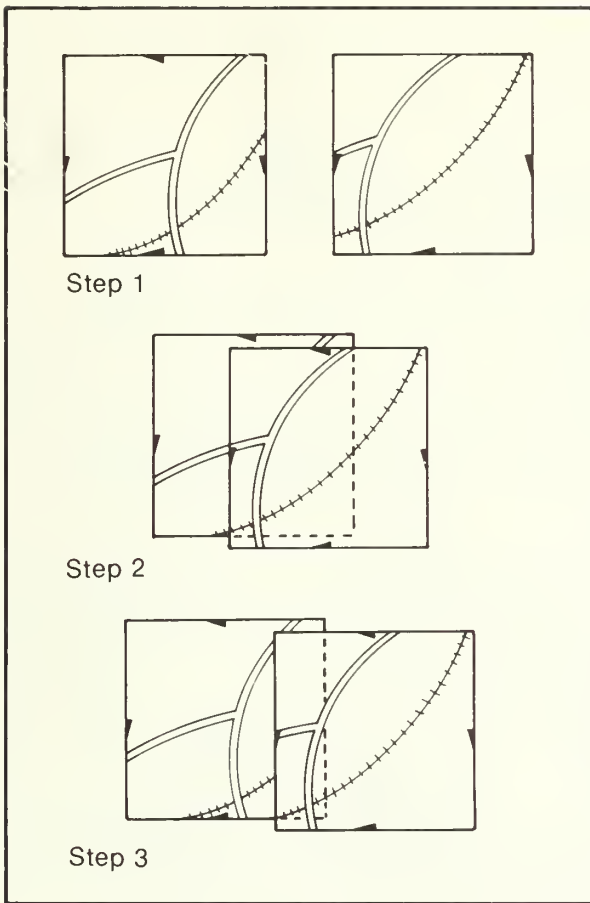

2-5

by moving the stereoscope up and down the overlap area.

Neophyte interpreters should follow these rules to develop proper stereoscopic viewing habits:

1. Make sure that photographs are properly aligned, with shadows falling toward the interpreter.
2. Maintain an even, glare-free illumination on prints or transparencies.
3. Keep stereoscope lenses clean and separated to your correct interpupillary distance.
4. At the onset, do not use the stereoscope more than 30 minutes out of any given one-hour period.

## Preparation of Stereograms

Stereograms are made by cutting out left-hand and right-hand views from overlapping

photographs and mounting them side by side on file cards for quick reference. For maximum utility, all features in a given category (e.g., tree species, landforms, or prehistoric structures) should be pictured on prints of the same scale, film and season. When stereogram cards are indexed according to subject and geographic locale, they comprise a photointerpretation "key" that is useful for training purposes and for identifying similar features on subsequent aerial surveys.

Overlapping vertical, oblique, or terrestrial photographs can be used for making stereograms. In some cases, views taken from two different camera angles are combined on the same stereogram card. Ground stereograms are most easily made with a 35 mm. stereo camera equipped with negative film. When a stereo camera is not available, however, three-dimensional pictures can be taken with any good camera, provided the objects being pictured remain stationary long enough for two separate exposures to be made.

If ground stereograms are to be studied under a lens stereoscope, a camera having a negative format of  $2\frac{1}{4}$  by  $2\frac{1}{4}$  in. is ideal for stereoscopic photography. The technique is as follows:

1. Frame the desired view carefully in the camera view-finder and mentally note the exact limits of the area photographed.
2. Move the camera several inches to the left or right on a parallel and level base line and take a second exposure. For later printing of views in their correct relative positions, make notes on whether left-hand or right-hand negatives were exposed first on the film roll.
3. After the two  $2\frac{1}{4}$  by  $2\frac{1}{4}$ -in. prints are mounted side by side, they are ready for three-dimensional study with a simple lens stereoscope.

It will be noted that when two separate exposures are taken for stereo-viewing, the three-dimensional effect is heightened by increasing the lateral distance (photo base) between left and right exposures. As a general rule, this photo base should measure three to four in. for objects 100 to 200 ft. away and four to ten in. for distant landscapes. For any given camera and subject, of course, the ideal separation is best obtained by trial and error.

## Section 3

# Photo Scale, Displacement, Areas, and Parallax

### Scale Determinations

Linear scale is the relationship between distances on an aerial photograph or map and the actual ground distance. Scale is normally expressed as a representative fraction (RF) in which the numerator is unity, such as 1/10,000, or as a ratio, such as 1:10,000. The numerical relationship is valid regardless of the unit of measure. Therefore, one in. on the map equals 10,000 in. on the ground or one m. on the map equals 10,000 m. on the ground.

The vertical aerial photograph presents a true record of angles, but measures of horizontal distances vary widely with changes in ground elevations and flight altitudes. The nominal scale (as 1:10,000) is representative only of the datum, an imaginary plane passing through a specified ground elevation above sea level. Calculation of the average photo scale will increase the accuracy of subsequent photo measurements.

The two most common techniques for determining photographic scale are the focal length/altitude method and the photo/ground distance method.

### Focal Length/Altitude Method

Aerial cameras in common use have focal lengths of 6, 8.25, or 12 in. (0.5, 0.6875, or 1.0 ft.). This information, coupled with the altitude of the aircraft above ground datum, makes it possible to determine the representative fraction (RF) or natural scale (fig. 3-1):

$$RF = \frac{\text{Focal length (ft.)}}{\text{Flying height above ground (ft.)}}$$

Both numerator and denominator must be expressed in the same units. For example, with a camera focal length of six inches (0.5 ft.) and a flight altitude of 7,500 ft. above ground, the scale would be computed as:

$$RF = \frac{0.5}{7,500} = \frac{1}{15,000} \text{ or } 1:15,000$$

Another application of this relationship might require determination of the flight altitude that must be maintained to obtain a specified photographic scale. Again assuming a focal length of six in., a specified scale of 1:12,000, and an average ground elevation of 2,000 ft., the flight altitude above mean sea level (MSL) would be:

$$\frac{1}{12,000} = \frac{0.5 \text{ ft}}{X - 2,000 \text{ ft}}$$

$$X - 2,000 \text{ ft} = 6,000 \text{ ft}$$

$$X = 8,000 \text{ ft above MSL}$$

### Photo/Ground Distance Method

While the foregoing method of deriving photo scale is theoretically sound, it often happens that either camera focal length or flight altitude is unknown to the interpreter. In such cases, scales may be determined by the relationship shown in figure 3-2:



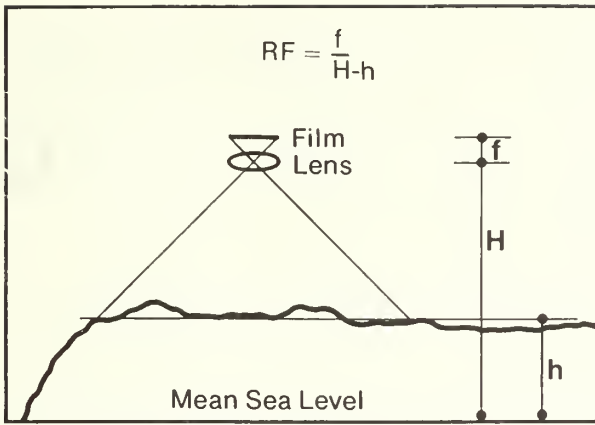

3-1 Relationship of camera focal length and height above ground (or mean sea level) to photo scale. Courtesy U.S. Army Engineer School, Ft. Belvoir, Virginia.

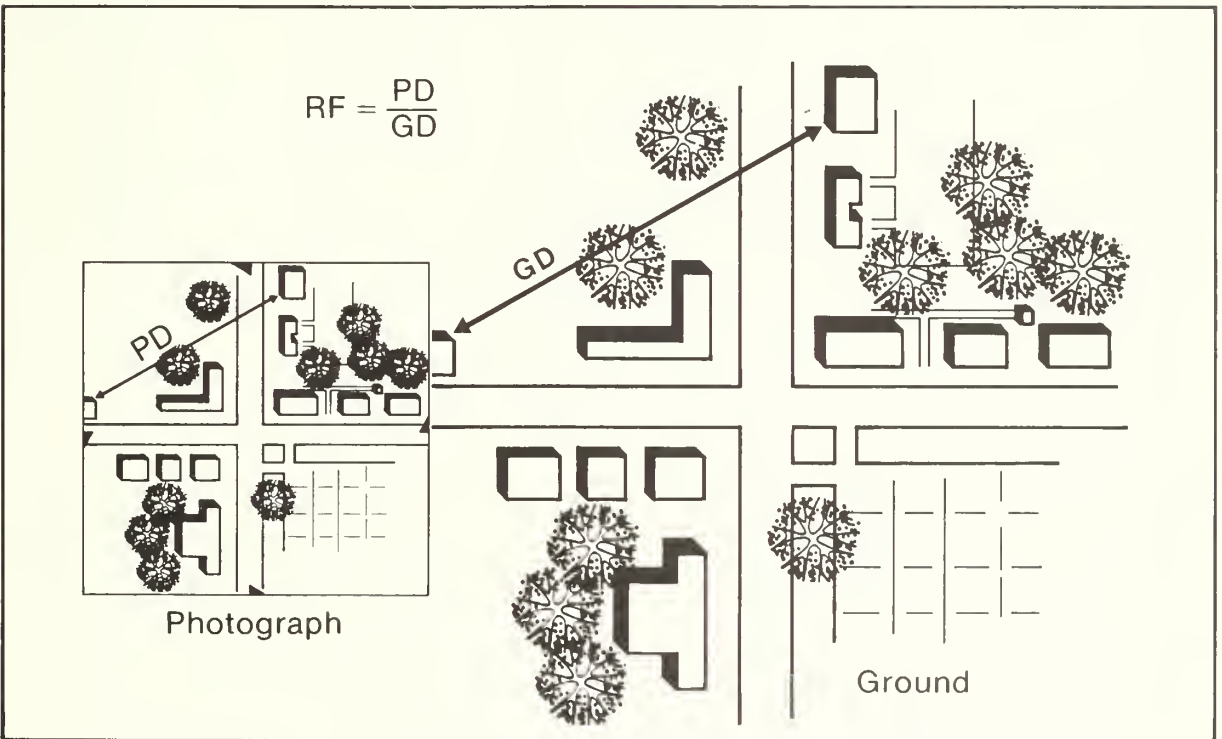

3-2 Application of photo distance (PD) and ground distance in determining photo scale. Courtesy U.S. Army Engineer School, Ft. Belvoir, Virginia.

$$RF = \frac{\text{Photo Distance between 2 pts.}}{\text{Ground Distance between same points}}$$

In using this method, photo and ground distances must be in the same units. If possible, the two points selected for measurement should be on opposite sides of the print so that a line connecting them passes near the principal point (PP). The principal point is the aerial photograph's optical center which is located at the

point where lines drawn from opposite fiducial marks cross (fig. 3-3). If the points are approximately equidistant from the PP, the effect of photographic tilt will be minimized. (Tilt results when the camera axis deviates from the vertical at the instant of exposure. It is often present, but generally not enough to be readily noticed.) Points must be easily identifiable on the ground so that the distance between them can be precisely measured. Gas and power line rights-of-way, highways, and railroads offer clearings where ground distances can be quickly chained.

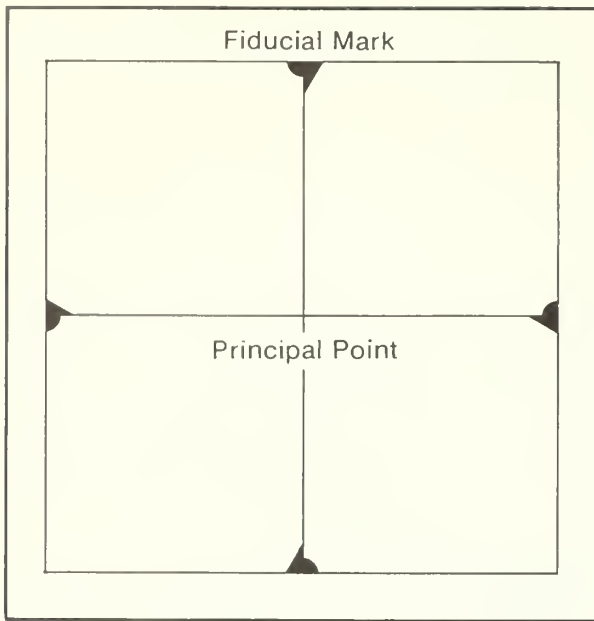

3-3 The principal point of a photograph is located at the point of intersection of straight lines drawn through opposite fiducial marks.

Another alternative is presented in areas of flat terrain where General Land Office subdivisions of sections, quarter-sections, and forties are visible on the photographs. Since the lengths of these subdivisions will be known, they can also be used as ground distances. A given section may rarely be exactly 5,280 ft. on a side, but determining scale by this method is more accurate than accepting the nominal scale.

The various methods of scale determination have several "error factors" in common. These include: (1) the limits of photographic resolution, (2) the stretching and shrinking of photos and maps, (3) distortions due to tilt displacement, and (4) distortions due to relief (terrain) configuration. In addition, the focal length/altitude method requires the determination of the effective altitude at which the photo was taken, giving due consideration to altimeter errors and the altitude above sea level of the area being photographed.

Table 3-1 lists conversion factors for a wide range of photographic and map scales.

## Photo Image Displacement

On planimetric maps, all features are shown in their correct horizontal positions. This is not true on aerial photographs, because of various sources of distortion or image displacement. There are three major sources of this distortion: optical or photographic deficiencies, tilting of the camera axis at the instant of exposure, and displacements due to relief (terrain variations).

If the camera lens is inferior, the image may be displaced inwardly or outwardly from its true position. This distortion may also be caused by faulty shutters, film shrinkage, or failure of the film-flattening mechanism in the camera. Modern cameras have almost eliminated this source of displacement.

Air currents and the periodic banking and tipping of the photographic airplane in the effort to keep a straight, level course tend to keep the aerial camera from a desired vertical position. And, any deviation from the vertical introduces tilt distortions into the photograph which make it impossible to determine ground distances by direct measurements.

In the field, lone trees or shrubs, rock outcrops, roads, fencelines and the like can often be used.

As an example, a photo distance of 0.359 ft., paired with a ground distance of 5,480 ft., would result in the following scale computation:

$$RF = \frac{0.359}{5,480} = \frac{1}{15,265} \text{ or } 1:15,265$$

## Quick Laboratory Checks of Photo Scale

Scale determination from ground measurements is laborious and expensive; hence other methods should be used wherever possible. If a U. S. Geological Survey quadrangle sheet is available, the map distance can be measured and substituted for ground measurements in the formula, provided the same distance can be identified for photo measurement.

**Table 3-1.** Scale conversions for vertical aerial photographs<sup>1</sup>

Representative Fraction (scale)	Feet per inch	Chains per inch	Inches per mile	Acres per square inch	Square miles per square inch
(1)	(2)	(3)	(4)	(5)	(6)
1: 7,920	660.00	10.00	8.00	10.00	0.0156
1: 8,000	666.67	10.10	7.92	10.20	0.0159
1: 8,400	700.00	10.61	7.54	11.25	0.0176
1: 9,000	750.00	11.36	7.04	12.91	0.0202
1: 9,600	800.00	12.12	6.60	14.69	0.0230
1:10,000	833.33	12.63	6.34	15.94	0.0249
1:10,800	900.00	13.64	5.87	18.60	0.0291
1:12,000	1,000.00	15.15	5.28	22.96	0.0359
1:13,200	1,100.00	16.67	4.80	27.78	0.0434
1:14,400	1,200.00	18.18	4.40	33.06	0.0517
1:15,000	1,250.00	18.94	4.22	35.87	0.0560
1:15,600	1,300.00	19.70	4.06	38.80	0.0606
1:15,840	1,320.00	20.00	4.00	40.00	0.0625
1:16,000	1,333.33	20.20	3.96	40.81	0.0638
1:16,800	1,400.00	21.21	3.77	45.00	0.0703
1:18,000	1,500.00	22.73	3.52	51.65	0.0807
1:19,200	1,600.00	24.24	3.30	58.77	0.0918
1:20,000	1,666.67	25.25	3.17	63.77	0.0996
1:20,400	1,700.00	25.76	3.11	66.34	0.1037
1:21,120	1,760.00	26.67	3.00	71.11	0.1111
1:21,600	1,800.00	27.27	2.93	74.38	0.1162
1:22,800	1,900.00	28.79	2.78	82.87	0.1295
1:24,000	2,000.00	30.30	2.64	91.83	0.1435
1:25,000	2,083.33	31.57	2.53	99.64	0.1557
1:31,680	2,640.00	40.00	2.00	160.00	0.2500
Method of calculation	$\frac{\text{RFD}}{12}$	$\frac{\text{RFD}}{792}$	$\frac{63,360}{\text{RFD}}$	$\frac{(\text{RFD})^2}{6,272,640}$	$\frac{\text{Acres/sq. in.}}{640}$

<sup>1</sup>Conversions for scales not shown can be made from the relationships listed at the bottom of each column. Using the scale of 1:7,920 as an example (col. 1, line 1), the number of feet per inch is computed by dividing the representative fraction denominator (RFD) by 12 (no. of inches per foot). Thus, 7,920 ÷ 12 = 660 feet per inch (col. 2). By dividing the RFD by 792 (inches per chain), the number of chains per inch is derived (col. 3). Other calculations can be made similarly. Under column 4, the figure 63,360 represents the number of inches in one mile; in column 5, the figure 6,272,640 is the number of square inches in one acre; and in column 6, the number 640 is acres per square mile.

The focus of tilt displacement is called the *isocenter*, a point that is found along the axis of tilt. Images are displaced radially toward the isocenter on the upper side of a tilted photograph and radially outward on the lower side. The axis of tilt is the only line of true scale on the photograph. In the direction of tilt from the axis of tilt, all lines are longer than on a truly vertical photograph. On the side of the axis opposite the direction of tilt, they are shorter. Tilt distortion becomes progressively greater the farther away a point is from the isocenter in the direction of tilt. For a detailed explanation of tilt and its effects see the *Manual of Photogrammetry*, 1966.

Fortunately, when photographs are inclined less than 3 degrees, the effect of tilt on most measurements is minimal. In such instances, photographs are presumed to be vertical, a condition where the isocenter coincides with the principal point.

## Relief Displacement

Relief displacement is present to some degree on all photographs; without some shift in an image's apparent position (as seen from two different camera stations) three-dimensional study of images would be impossible.

The general rule is that objects below a horizontal reference plane are displaced toward the center (nadir) of the photograph and points above the plane are displaced away from the center (nadir) (fig. 3-4). The nadir is technically defined as the point at which the plane of the photograph is pierced by a vertical line extended from the ground through the center of the camera lens. The principal point is commonly accepted as the nadir position when photographic tilt does not exceed 2 or 3 degrees.

An object found precisely at the plumb point (nadir) of a vertical photograph will not be

3-4

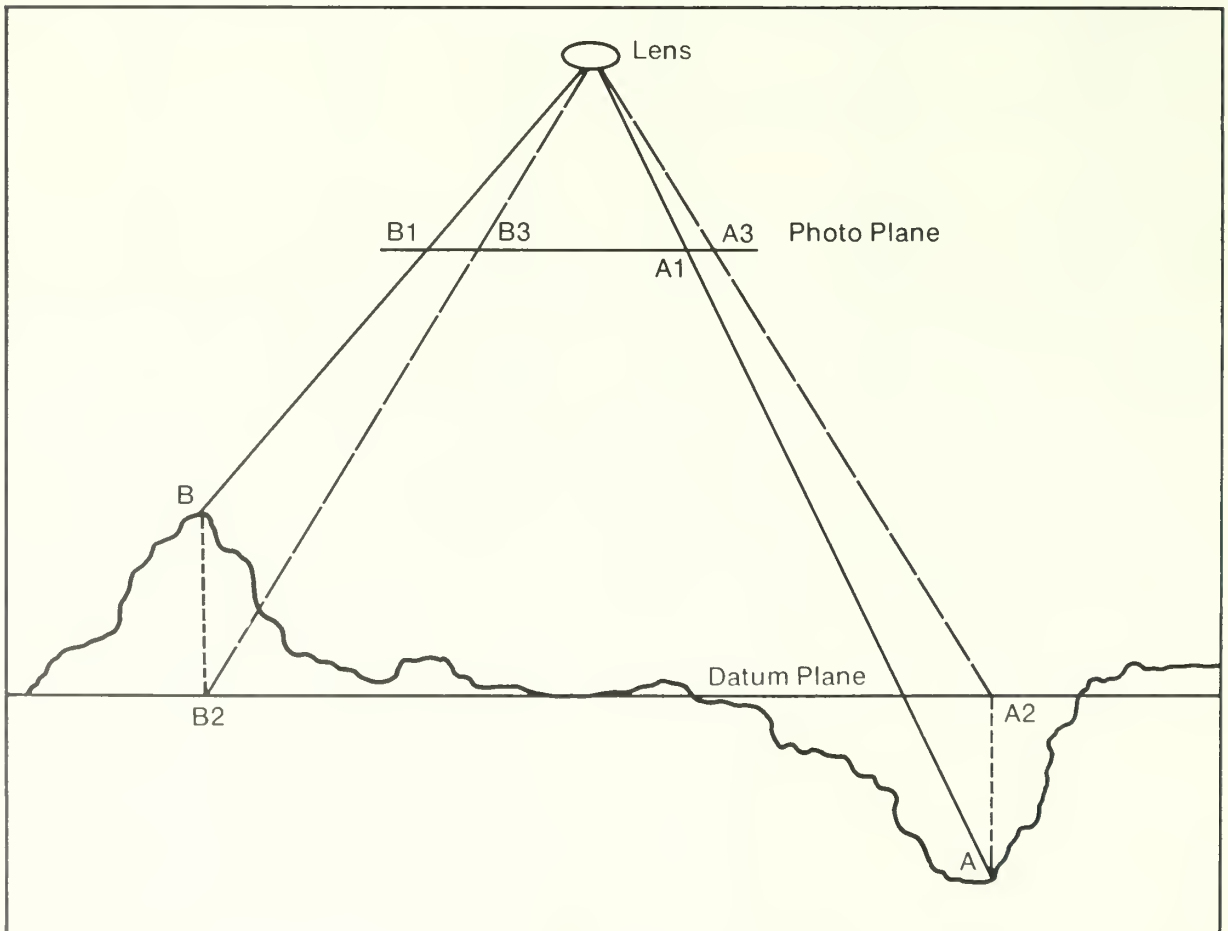

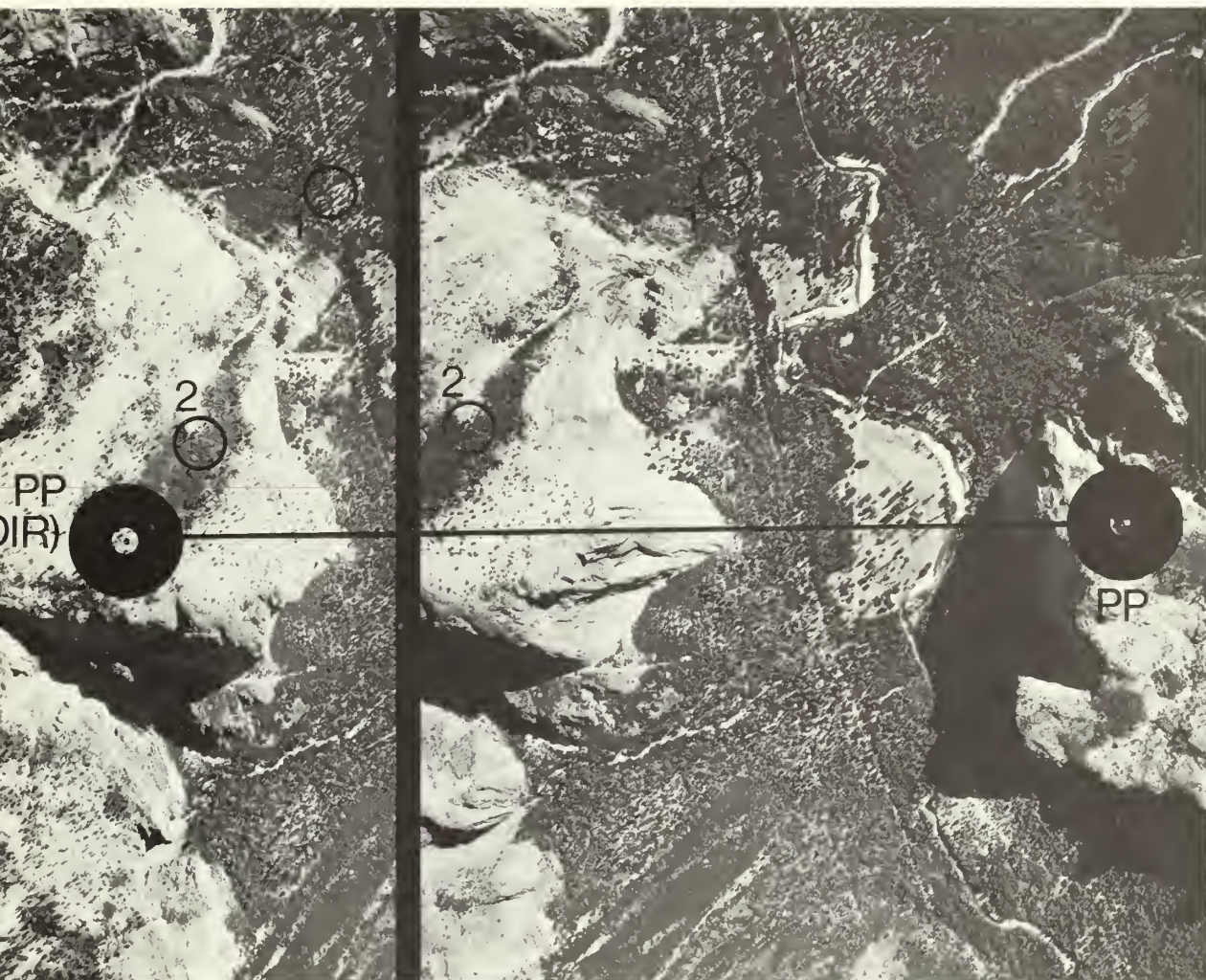

3-5 Stereogram of precipitous terrain in Yosemite National Park, California. The line connecting the two principal points (or nadirs) represents the path of flight. The excessive degree of image displacement makes stereoscopic viewing difficult except at lower elevations. Compare the difference in elevation between points 1 and 2.

3-4 Points below a datum plane are displaced toward the center (nadir) of an aerial photograph (point A). Points above a datum plane are displaced away from the nadir of the photograph (point B).

displaced at all, regardless of the relief of the ground or the datum used. Also, an image at the elevation of the datum will not be displaced, regardless of its horizontal position.

Figure 3-5 illustrates an outstanding example of relief displacement. On the left photograph, the mountain peak is almost directly under the camera lens, and relief displacement is minimal. On the right photo, however, the face of the same cliff "leans away" from the nadir because of the perspective view of the camera lens. Trees along the valley road may be viewed three-dimensionally, but the abrupt rise of over 2,000 feet precludes stereoscopic fusion of the displaced peaks.

The numbered arrows in this illustration substantiate the fact that objects at high elevations are displaced farther from their nadirs than features at or near ground datum. The distance between corresponding images at point 2 (high elevation) is much less than that between images at point 1 (low elevation). As outlined in the pages that follow, this characteristic of relative image displacement on adjacent photographs can be used in the stereoscopic determination of differences in elevation.

## Measuring Areas

Photographs offer an inexpensive means of making area determinations. In locations where

photo scales are not appreciably altered by topographic changes, areas can be measured directly on contact prints. Greater accuracy is possible if boundaries are transferred to controlled base maps before area is determined. This procedure is essential for mountainous terrain.

The problem of scale changes due to relief is illustrated by Table 3-2 for photographs at a *nominal scale* of 1:12,000. When the nominal scale is applied, the area equivalent is 22.96 acres per sq. in.; on a plateau 500 feet above ground datum, the conversion is only 19.29 acres per sq. in. Conversely, the value of 26.94 would be used for depressions 500 ft. below the datum plane. Thus, it is apparent that large errors will be incurred unless new conversions are computed for each significant variation in land elevation.

**Table 3-2.** Effect of topographic changes on area equivalents for 1:12,000 aerial photographs<sup>1</sup>

Change in elevation	Actual flying height	Corrected photo scale	Equivalent area per square inch
feet	feet	R.F.	acres
- 1,000	7,000	1:14,000	31.25
- 900	6,900	1:13,800	30.36
- 800	6,800	1:13,600	29.49
- 700	6,700	1:13,400	28.63
- 600	6,600	1:13,200	27.78
- 500	6,500	1:13,000	26.94
- 400	6,400	1:12,800	26.12
- 300	6,300	1:12,600	25.31
- 200	6,200	1:12,400	24.51
- 100	6,100	1:12,200	23.73
0	6,000	1:12,000	22.96
+ 100	5,900	1:11,800	22.20
+ 200	5,800	1:11,600	21.45
+ 300	5,700	1:11,400	20.72
+ 400	5,600	1:11,200	20.00
+ 500	5,500	1:11,000	19.29
+ 600	5,400	1:10,800	18.60
+ 700	5,300	1:10,600	17.91
+ 800	5,200	1:10,400	17.24
+ 900	5,100	1:10,200	16.59
+ 1,000	5,000	1:10,000	15.94

<sup>1</sup>Assumes a camera focal length of six inches.

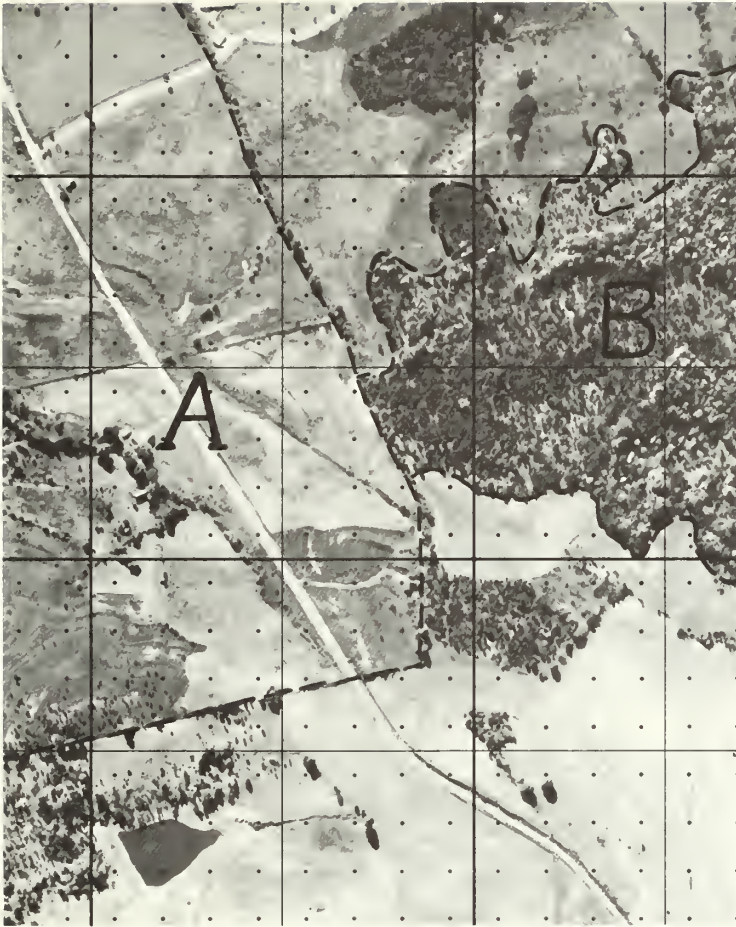

3-6 Dot grid with 16 dots per sq. in. oriented over a photograph taken at a scale of 660 ft. per in., or 10 acres per sq. in.

## Planimeters and Dot Grids

**Polar planimeters**, sometimes called areameters, are available to most interpreters, although they are relatively expensive by comparison with other devices, such as dot grids. In use, the pointer of the instrument is carefully run around the boundaries of the area in a *clockwise* direction. As a rule, the perimeter is traced two or three times for an average reading. From the vernier scale, the area in *sq. in.* or *sq. cm* is read and converted to desired units, usually acres or hectares, on the basis of photo or map scale.

**Dot grids** are the most popular means for area determinations on maps and aerial photographs. A dot grid is a transparent overlay with dots systematically arranged on a grid pattern

(fig. 3-6). In use, the grid is placed in a random fashion over the area to be measured (to avoid positioning bias) and dots within the area are counted. The dot count is then converted to acres (or other area units) by this relationship:

$$\frac{\text{Scale in acres/sq. in.}}{\text{No. of dots/sq. in.}} = \text{No. acres/dot}$$

As an example, the conversion for the dot grid pictured in figure 3-6 would be computed as:

$$\frac{10 \text{ acres/sq. in.}}{16 \text{ dots/sq. in.}} = 0.625 \text{ acres/dot}$$

## The Parallax Formula

**Parallax** is the apparent displacement of an object relative to another object (or relative to its background) caused by a change in the position of observation. In measuring object heights on stereoscopic pairs of aerial photographs, two types of parallax must be measured or approximated—the absolute and the differential. The absolute stereoscopic parallax of a point is “the algebraic difference, parallel to the air base, of the distance of the two images from their respective principal points.” The parallax difference, or differential parallax, of an object being measured for height determination is the difference in the absolute stereoscopic parallax at the top and the base of the object, measured parallel to the air base or flight line.

The formula for converting parallax measurements to object heights on aerial photographs is:

$$h = (H) \frac{dP}{P + dP}$$

where  $h$  = height of object

$H$  = altitude of aircraft above ground datum

$P$  = absolute stereoscopic parallax at base of object being measured

$dP$  = differential parallax

If object heights are to be determined in feet, the height of the aircraft ( $H$ ) must also be in ft. Absolute stereoscopic parallax ( $P$ ) and differential parallax ( $dP$ ) must be expressed in the same units; ordinarily, these units will be thousandths of inches or hundredths of millimetres.

The height of the aircraft above ground datum is calculated from the basic scale formula, transposed to the more convenient form: Flight altitude ( $H$ ) = focal length  $\times$  scale denominator. With photographs of 1:20,000 scale and a camera of 8.25-in. focal length, the flight altitude would be  $0.6875 \times 20,000 = 13,750$  ft.

In flat terrain, the average photo base length is ordinarily substituted as the absolute stereoscopic parallax ( $P$ ). Differential parallax ( $dP$ ) is usually measured stereoscopically with either a parallax wedge or parallax bar, employing the “floating mark” principle.

## The Parallax Wedge

Parallax wedges are usually printed on transparent film or glass. The basic design consists of two rows of dots or graduated lines beginning about 2.5 in. apart and converging to about 1.8 in. apart. The graduations on each line are calibrated for making parallax readings to the nearest 0.002 in. The “training wedge” in figure 3-7 is graduated for reading to the nearest 0.01 in. only.

The parallax wedge is placed over the stereoscopic image with the converging lines perpendicular to the line of flight and adjusted until a single fused line of dots or graduations is seen sloping downward through the stereoscopic image. If the photo images are separated by exactly 2 in., a portion of the parallax wedge centering around the 2-in. separation of converging lines will fuse and appear as a single line. The line will appear to split above and below this section. Using the fused line of graduations, the differential parallax is obtained by counting the number of dots or intervals between the point where a graduation appears to rest on the ground and the point where a graduation appears to “float” in the air at the same height as the top of the object. In figure 3-7, for example, the dot resting on the road at “A” yields a reading of 2.33 in. When this value is subtracted from the creek-bed (“B”) reading of 2.41 in.,  $dP$  is determined as 0.08 in. With a flight altitude ( $H$ ) of 6,000 ft. and a photo base length of 3.10 in., the parallax formula yields:

$$\begin{aligned} h &= (6,000) \frac{0.08}{3.10 + 0.08} \\ &= 150 \text{ ft (difference in elevation)} \end{aligned}$$

## The Parallax Bar or Stereometer

This instrument is more expensive than the parallax wedge and yields results of comparable accuracy. But many interpreters prefer the parallax bar because the floating dot is movable and thus easier to place at the tops and bases of objects. A parallax bar designed to measure heights with a mirror stereoscope is shown in figure 3-8.



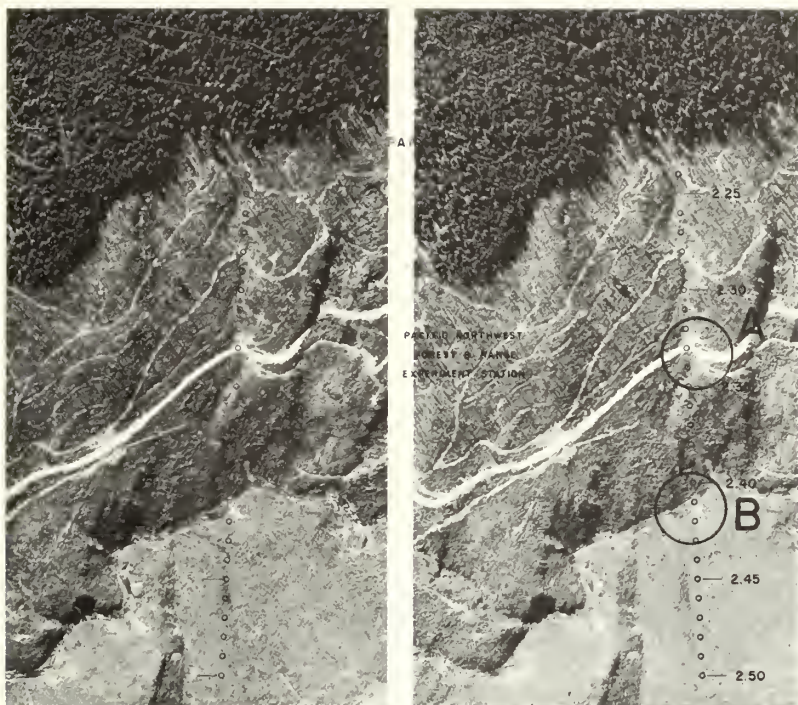

3-7 Parallax wedge oriented over a stereogram of a recently logged area. Graduations on right side indicate the separation of the converging lines to the nearest 0.01 in.

3-8 Mirror stereoscope with an attached parallax bar for measuring heights of objects. Courtesy Carl Zeiss, Oberkochen.

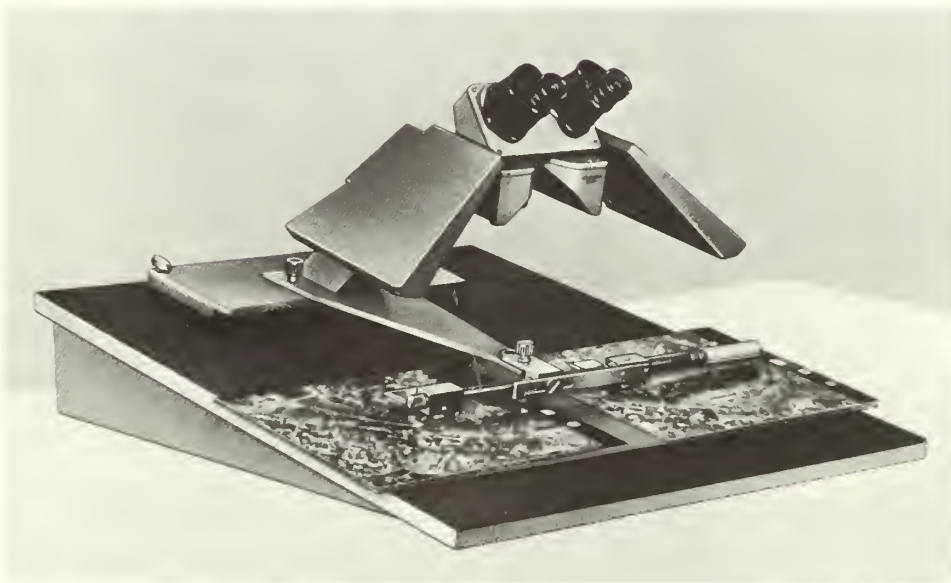

The bar has two lenses attached to a metal frame that houses a vernier and a graduated metric scale. The left lens contains the fixed reference dot; the dot on the right lens can be moved laterally by means of the vernier. The bar is placed over the stereoscopic image parallel to the line of flight. The right-hand dot is moved until it fuses with the reference dot and appears to rest on the ground. The vernier read-

ing is recorded to the nearest 0.01 mm. The vernier is then turned until the fused dot appears to “float” at the height of the object, and a second reading recorded. The difference between the readings is the parallax difference ( $dP$ ) in mm. This value can be substituted in the parallax formula without conversion if the absolute parallax ( $P$ ) is also expressed in mm.

# Precision of Height Measurements

Accuracy in measuring total heights of objects depends upon a number of factors, not the least of which is the interpreter's ability to determine stereoscopic parallax. Usually, interpreters can detect differences in parallax of about 0.002 in., or 0.05 mm., and this graduation interval is used on most parallax wedges.

Tables 3-3 and 3-4 were compiled for various photo base lengths and flying heights by iterative solutions of the parallax formula. Since Table 3-3 is based on a parallax difference of 0.002 in., it thus provides an approximation of the measurement precision that can be expected by skilled interpreters.

**Table 3-3.** Parallax-wedge conversion factors for wedges reading to 0.002-inch parallax (dP)<sup>1</sup>

Average photo base (P)	Average flying height (H) above ground datum in feet										Average photo base (P)
	2,000	4,000	6,000	8,000	10,000	12,000	14,000	16,000	18,000	20,000	
<i>Inches</i>	<i>Object heights (ho) in feet per 0.002 inch</i>										<i>Inches</i>
2.1	1.9	3.8	5.7	7.6	9.5	11.4	13.3	15.2	17.1	19.0	2.1
2.2	1.8	3.6	5.4	7.3	9.1	10.9	12.7	14.5	16.3	18.2	2.2
2.3	1.7	3.5	5.2	7.0	8.7	10.4	12.2	13.9	15.6	17.4	2.3
2.4	1.7	3.3	5.0	6.7	8.3	10.0	11.7	13.3	15.0	16.6	2.4
2.5	1.6	3.2	4.8	6.4	8.0	9.6	11.2	12.8	14.4	16.0	2.5
2.6	1.5	3.1	4.6	6.1	7.7	9.2	10.8	12.3	13.8	15.4	2.6
2.7	1.5	3.0	4.4	5.9	7.4	8.9	10.4	11.8	13.3	14.8	2.7
2.8	1.4	2.8	4.3	5.7	7.1	8.6	10.0	11.4	12.8	14.3	2.8
2.9	1.4	2.8	4.1	5.5	6.9	8.3	9.6	11.0	12.4	13.8	2.9
3.0	1.3	2.7	4.0	5.3	6.7	8.0	9.3	10.7	12.0	13.3	3.0
3.1	1.3	2.6	3.9	5.2	6.4	7.7	9.0	10.3	11.6	12.9	3.1
3.2	1.2	2.5	3.7	5.0	6.2	7.5	8.7	10.0	11.2	12.5	3.2
3.3	1.2	2.4	3.6	4.8	6.1	7.3	8.5	9.7	10.9	12.1	3.3
3.4	1.2	2.3	3.5	4.7	5.9	7.0	8.2	9.4	10.6	11.8	3.4
3.5	1.1	2.3	3.4	4.6	5.7	6.8	8.0	9.1	10.3	11.4	3.5
3.6	1.1	2.2	3.3	4.4	5.6	6.7	7.8	8.9	10.0	11.1	3.6
3.7	1.1	2.2	3.2	4.3	5.4	6.5	7.6	8.6	9.7	10.8	3.7
3.8	1.0	2.1	3.1	4.2	5.3	6.3	7.4	8.4	9.5	10.5	3.8
3.9	1.0	2.0	3.1	4.1	5.1	6.1	7.2	8.2	9.2	10.2	3.9
4.0	1.0	2.0	3.0	4.0	5.0	6.0	7.0	8.0	9.0	10.0	4.0
4.1	0.98	2.0	2.9	3.9	4.9	5.8	6.8	7.8	8.8	9.8	4.1
4.2	0.95	1.9	2.9	3.8	4.8	5.7	6.7	7.6	8.6	9.5	4.2
4.3	0.93	1.9	2.8	3.7	4.6	5.6	6.5	7.4	8.4	9.3	4.3
4.4	0.91	1.8	2.7	3.6	4.5	5.4	6.4	7.3	8.2	9.1	4.4
4.5	0.89	1.8	2.7	3.6	4.4	5.3	6.2	7.1	8.0	8.9	4.5

<sup>1</sup>To use table, measure parallax difference (dP) of object to nearest 0.002 inch (as 0.016 or 8 dot intervals on wedge). If average photo base (P) is 3.6 inches and flight altitude is 14,000 feet, the table value of 7.8 is multiplied by the 8 dot intervals for an object height of 62 feet. Linear interpolations may be made in the table for determining conversion factors not shown.

Table 3-4. Parallax-bar conversion factors for devices reading to 0.01-mm. parallax (dP)<sup>1</sup>

Average photo base(P)	Average flying height (H) above ground datum in feet															Average photo base(P)				
	2,500	3,000	3,500	4,000	4,500	5,000	5,500	6,000	6,500	7,000	7,500	8,000	8,500	9,000	9,500		10,000	10,500	11,000	
	<i>Object heights (ho) in feet per millimeter</i>																			
<i>Inches</i>	<i>Object heights (ho) in feet per millimeter</i>																			<i>Inches</i>
2.1	46	55	64	74	83	92	101	110	120	129	138	147	157	166	175	184	193	203	211	2.1
2.2	44	53	62	70	79	88	97	105	114	123	132	141	149	158	167	176	185	193	202	2.2
2.3	42	50	59	67	76	84	93	101	109	118	126	135	143	152	160	168	177	185	194	2.3
2.4	40	48	56	65	73	81	89	97	105	113	121	129	137	145	153	161	169	177	186	2.4
2.5	39	47	54	62	70	78	85	93	101	109	116	124	132	140	147	155	163	171	180	2.5
2.6	37	45	52	60	67	75	82	90	97	104	112	119	127	134	142	149	157	164	173	2.6
2.7	36	43	50	57	65	72	79	86	93	101	108	115	122	129	136	144	151	158	167	2.7
2.8	35	42	49	55	62	69	76	83	90	97	104	111	118	125	132	139	146	153	162	2.8
2.9	33	40	47	54	60	67	74	80	87	94	100	107	114	120	127	134	141	147	155	2.9
3.0	32	39	45	52	58	65	71	78	84	91	97	104	110	117	123	130	136	142	150	3.0
3.1	31	38	44	50	56	63	69	75	82	88	94	100	107	113	119	125	132	138	146	3.1
3.2	30	36	43	49	55	61	67	73	79	85	91	97	103	109	115	122	128	134	143	3.2
3.3	29	35	41	47	53	59	65	71	77	83	88	94	100	106	112	118	124	130	140	3.3
3.4	29	34	40	46	51	57	63	69	74	80	86	92	97	103	109	114	120	126	137	3.4
3.5	28	33	39	44	50	56	61	67	72	78	83	89	95	100	106	111	117	122	134	3.5
3.6	27	32	38	43	49	54	60	65	70	76	81	87	92	97	103	108	114	119	132	3.6
3.7	26	32	37	42	47	53	58	63	68	74	79	84	89	95	100	105	111	116	130	3.7
3.8	26	31	36	41	46	51	56	62	67	72	77	82	87	92	97	103	108	113	128	3.8
3.9	25	30	35	40	45	50	55	60	65	70	75	80	85	90	95	100	105	110	126	3.9
4.0	24	29	34	39	44	49	54	58	63	68	73	78	83	88	93	97	102	107	124	4.0
4.1	24	29	33	38	43	48	52	57	62	67	71	76	81	86	90	95	100	105	122	4.1
4.2	23	28	32	37	42	46	51	56	60	65	70	74	79	84	88	93	97	102	120	4.2
4.3	23	27	32	36	41	45	50	54	59	64	68	73	77	82	86	91	95	100	118	4.3
4.4	22	27	31	35	40	44	49	53	58	62	66	71	75	80	84	89	93	98	116	4.4
4.5	22	26	30	35	39	43	48	52	56	61	65	69	74	78	82	87	91	95	114	4.5

Table 3-4. Parallax-bar conversion factors for devices reading to 0.01-mm. parallax (dP)<sup>1</sup>. (continued)

Average photo base (P)	Average flying height (H) above ground datum in feet															Average photo base (P)			
	11,500	12,000	12,500	13,000	13,500	14,000	14,500	15,000	15,500	16,000	16,500	17,000	17,500	18,000	18,500		19,000	19,500	20,000
Inches	Object heights (ho) in feet per millimeter																		
2.1	212	221	230	239	249	258	267	276	285	295	304	313	322	331	341	350	359	368	2.1
2.2	202	211	220	228	237	246	255	264	272	281	290	299	308	316	325	334	343	352	2.2
2.3	194	202	210	219	227	236	244	253	261	269	278	286	295	303	311	320	328	337	2.3
2.4	185	194	202	210	218	226	234	242	250	258	266	274	282	290	298	306	315	323	2.4
2.5	178	186	194	202	209	217	225	233	240	248	256	264	271	279	287	295	302	310	2.5
2.6	172	179	187	194	201	209	216	224	231	239	246	254	261	269	276	284	291	298	2.6
2.7	165	172	180	187	194	201	208	216	223	230	237	244	251	259	266	273	280	287	2.7
2.8	159	166	173	180	187	194	201	208	215	222	229	236	243	250	257	264	270	277	2.8
2.9	154	161	167	174	181	187	194	201	207	214	221	228	234	241	248	254	261	268	2.9
3.0	149	155	162	168	175	181	188	194	201	207	214	220	227	233	240	246	253	259	3.0
3.1	144	151	157	163	169	176	182	188	194	201	207	213	220	226	232	238	245	251	3.1
3.2	140	146	152	158	164	170	176	182	188	194	200	207	213	219	225	231	237	243	3.2
3.3	136	142	147	153	159	165	171	177	183	189	195	200	206	212	218	224	230	236	3.3
3.4	132	137	143	149	154	160	166	172	177	183	189	194	200	206	212	217	223	229	3.4
3.5	128	133	139	145	150	156	161	167	172	178	184	189	195	200	206	211	217	222	3.5
3.6	124	130	135	141	146	152	157	162	168	173	179	184	189	195	200	206	211	216	3.6
3.7	121	126	132	137	142	147	153	158	163	168	174	179	184	189	195	200	205	211	3.7
3.8	118	123	128	133	138	144	149	154	159	164	169	174	179	185	190	195	200	205	3.8
3.9	115	120	125	130	135	140	145	150	155	160	165	170	175	180	185	190	195	200	3.9
4.0	112	117	122	127	132	136	141	146	151	156	161	166	171	175	180	185	190	195	4.0
4.1	109	114	119	124	128	133	138	143	147	152	157	162	167	171	176	181	186	190	4.1
4.2	107	111	116	121	125	130	135	139	144	149	153	158	162	167	172	176	181	186	4.2
4.3	104	109	113	118	123	127	132	136	141	145	150	154	159	163	168	172	177	181	4.3
4.4	102	106	111	115	120	124	129	133	137	142	146	151	155	160	164	168	173	177	4.4
4.5	100	104	108	113	117	121	126	130	134	139	143	147	152	156	160	165	169	173	4.5

<sup>1</sup>To use table, measure parallax difference (dP) of object to nearest hundredth of a millimeter (as 0.41 mm., for example). If average photo base (P) is 3.1 inches and flying height (H) is 15,000 feet, the conversion factor of 188 is multiplied by 0.41 for an object height of 77 feet. Linear interpolations may be made in the table for determining conversion factors not shown.

# Sources of Existing Imagery and Maps

## Introduction

Aerial imagery can be obtained by purchasing prints of existing photographs, by taking the necessary pictures yourself, or by contracting for new coverage through a private aerial-survey company. Each solution has its own advantages and limitations. For example, existing photography has the advantage of low cost, but it may be outdated or available only in certain formats or film types. Do-it-yourself photography is often sufficient for small areas or spot coverage, but the amateur rarely has the equipment and professional expertise to photograph large land areas with required standards of precision. Contracting for a special aerial survey, the choice most likely to result in superior pictures, may be rather costly for small or irregularly shaped land areas.

## Photography from U.S. Government Agencies

Most of the United States has been photographed in recent years for various federal agencies. The key to this photography is available free in map form as the "Status of Aerial Photography in the U. S." Copies may be obtained by writing to:

Map Information Office  
U. S. Department of the Interior  
Geological Survey, National Center  
Reston, Virginia 22092

This map shows all areas of the United States, by counties, that have been photographed by or for: Agricultural Stabilization and Conservation Service, Soil Conservation Service, Forest Service, Geological Survey, Corps of Engineers, Air Force, National Ocean Survey (formerly, Coast and Geodetic Survey), and commercial firms. Names and addresses of agencies holding the negatives for the photographs are printed on the back of the map, and inquiries should be sent directly to the appropriate organization. There is no central laboratory that can furnish prints of all government photography.

Negatives for the largest proportion of recent aerial photography are held by the Agricultural Stabilization and Conservation Service (ASCS), Forest Service (FS), and the Geological Survey (GS). Typical coverage is panchromatic-minus blue photography taken at scales of 1:12,000 to 1:40,000. Inquiries to these three agencies may be addressed as follows:

ASCS—USDA  
Aerial Photography Field Office  
2505 Parley's Way  
Salt Lake City, Utah 84109

Chief, Forest Service  
U. S. Department of Agriculture  
Washington, D. C. 20250

U. S. Geological Survey  
Federal Center  
Denver, Colorado 80225

Photographic prints may be obtained with glossy or semi-matte finishes. Glossy prints provide fine image resolution and contrast, but exhibit an offensive glare under ordinary illumination. Also they are difficult to write upon and

may develop emulsion cracks under excessive handling. Semi-matte prints are usually preferred, because they are less reflective and more receptive to pencil and ink markings. Either single- or double-weight prints can be obtained from most agencies. Single-weight papers are suitable for office use, take up less filing space, and are easy to handle under the lens stereoscope. Double-weight prints are preferred for field use, however, as they are less subject to dimensional changes and withstand handling better than single-weight prints.

Few large areas have been photographed in color for federal agencies, but some national forests have coverage on black-and-white infrared film. The age of existing photography usually varies from two to eight years, with important agricultural regions and urban fringe areas being rephotographed at the most frequent intervals.

## Local Photographic Coverage

Inquiries regarding existing photography in one's own county can be made at local agency offices of the ASCS, FS, and GS. In some regions, the Soil Conservation Service (SCS) may

also hold local coverage. Photo index sheets or index mosaics, showing the relative positions of all individual photographs within a given county, are helpful for deciding which prints to order (fig. 4-1).

First, the boundaries of the desired area can be outlined on the photo index. All photographs that overlap this area, partially or completely, should be included to ensure stereo-coverage. An estimate of the number of prints required to cover various-sized areas can be made from Table 4-1. Prints should be listed by project symbol, roll number, and exposure number. Other items to specify in ordering are: date of photography, scale, print weight, and type of finish desired.

Photographic order blanks, including current prices, can be obtained by writing to the appropriate laboratory or agency. Orders must be accompanied by payment in advance, and six to eight weeks should be allowed for delivery.

4-1 Section of an aerial photo index sheet covering part of the Kaibab National Forest, Coconino County, Arizona. Original negative scale was 4 in./mile; index scale is about 1 in./mile. *US Forest Service photograph.*

**Table 4-1** Approximate number of exposures required for stereoscopic coverage, by size of area and scale\*

Size of Area	Negative scale: 9 by 9-inch format			
	1:5,000	1:10,000	1:20,000	1:40,000
Square miles	Number of exposures			
25	179	46	12	3
50	358	91	23	6
100	715	182	46	12
500	3,572	910	229	58
1,000	7,143	1,819	457	115
5,000	35,715	9,091	2,284	571
Sq mi/photo	0.14	0.55	2.19	8.77

\*Assumes an average forward overlap of 60 percent and an average sidelap of 30 percent, or an effective area of about 22 square inches per exposure. For each flight line planned, four exposures should be added to the numbers indicated.



## Satellite and High-Altitude Imagery

Photography and imagery of the earth taken from spacecraft and high-altitude aircraft, acquired by the National Aeronautics and Space Administration (NASA), the Geological Survey (GS), or the Bureau of Land Management (BLM), are available from:

EROS Data Center  
Data Management Center  
Sioux Falls, South Dakota 57198

Browse files, 16-mm films of the available data, can be viewed at 20 locations maintained by the EROS Program throughout the United States in order to evaluate the coverage prior to purchase.

## Imagery from the Canadian Government

The National Air Photo Library of Canada contains approximately 3 million oblique, vertical, and trimetrogon photographs that provide aerial coverage of most of the country. Established in 1925, this library is the repository and order-receiving agency for all Canadian federally-flown aerial photography, remote sensing (multi-spectral) imagery, and all LANDSAT imagery recorded over Canada.

To obtain additional information on Canadian photographic coverage, interested parties may write:

The National Air Photo Library  
Surveys and Mapping Building  
615 Booth Street  
Ottawa, Ontario K1A 0E9  
Canada

In addition, each provincial government maintains an aerial photographic library of photography flown under provincial auspices. Inquiries regarding provincial photo coverage should be addressed to the government of the province concerned, located in the provincial capital.

To speed up the selection process, all requests should include:

1. A marked map or tracing overlay outlining the area of desired coverage.
2. Whether stereo coverage is required.
3. The purpose for which the photographs will be used.

Clients will be advised of cost by the library contacted.

## Photography from Commercial Firms

A wide selection of photographic negatives are held by private aerial survey companies in the United States and Canada. As a rule, prints can be ordered directly from these companies after obtaining permission of the original purchaser. A large share of the available coverage has been obtained on panchromatic film with aerial cameras having 6-inch, distortion-free lenses. As a result, prints are ideally suited for stereoscopic study because of fine image resolution and a high degree of three-dimensional exaggeration. Scales are often 1:15,840 or larger for recent photography. In addition to contact prints and photo index sheets, most aerial mapping organizations will also sell reproductions of special atlas sheets or controlled mosaics. These items are often useful for pictorial displays and administrative planning.

Prints purchased from private companies may cost more than those from public agencies, but they are often of higher quality and at larger scales—factors that may offset any price differential. Quotations and photo indexes can be obtained by direct inquiry to the appropriate company. Names and addresses of leading photogrammetric concerns are available in current issues of *Photogrammetric Engineering and Remote Sensing*, the journal of the American Society of Photogrammetry.

## Taking Your Own Photographs

If oblique or near-vertical photographs taken with hand-held cameras are sufficient for reconnaissance of small areas, the do-it-yourself



approach may be a satisfactory solution for certain archeological air-survey projects. An unobstructed side view can be obtained from most high-wing monoplanes, and even better visibility is provided if the aircraft door can be removed during photographic flights. For oblique views, a standard 4 x 5 in. press camera works very well. Many Kodak professional films are available in the 4 x 5 in. sheet-film size.

Where the camera must be exposed to the aircraft slipstream, or where near-vertical coverage is desired, a rigidly designed aerial camera should be used instead. Such cameras may be rented, or they may be purchased at relatively low cost through military-surplus outlets. Lightweight military-reconnaissance cameras such as the K-20 and K-25 have been employed by some archeologists for making periodic aerial surveys of small sites and on-going excavations. Check with a photo dealer regarding the availability of films in various sizes before purchasing an aerial camera which might have a nonstandard negative format.

## Topographic Maps

Topographic quadrangle maps have been prepared for most areas of the United States by various government agencies. Such maps are ideal for planning photographic flights, surveys, and area estimations. Current indexes showing map coverage available in each of the 50 states may be obtained from the USGS Map Information Office at the address cited earlier in this section.

When available, quadrangle sheets at large scales (1:20,000 to 1:25,000) usually provide the greatest amount of detail (Table 4-2). Maps for areas west of the Mississippi River, including all of Louisiana and Minnesota, can be purchased from:

U. S. Geological Survey  
Distribution Section  
Federal Center  
Denver, Colorado 80225

For areas east of the Mississippi River, including Puerto Rico and the Virgin Islands, maps may be purchased from:

U. S. Geological Survey  
Distribution Section  
Washington, D. C. 20244

Maps of Hawaii may be ordered at either address. Mail orders should be accompanied by payment in advance.

In Canada, series maps of the national topographic system range in scale from 1:25,000 to 1:1,000,000. These may be purchased from:

Map Distribution Office  
Surveys and Mapping Branch  
Department of Mines and Technical Surveys  
615 Booth Street  
Ottawa, Ontario K1A 0E9  
Canada

**Table 4-2** Scales of national topographic maps available from the U.S. Geological Survey

Map series and scale	Quadrangle size (latitude—longitude)	Quadrangle area (square miles)
Puerto Rico 1:20,000	7½ by 7½ minutes	71
United States 1:24,000	7½ by 7½ minutes	49 to 70
United States 1:62,500	15 by 15 minutes	197 to 282
Alaska 1:63,360	15 by 20-36 minutes	207 to 281
United States 1:250,000	1 by 2 degrees <sup>1</sup>	4,580 to 8,669
United States 1:1,000,000	4 by 6 degrees <sup>1</sup>	73,734 to 102,759

<sup>1</sup>Maps of Alaska and Hawaii vary from these standards.

## Section 5

# Simple Mapping Techniques

### Photographs as Map Substitutes

Because of the perspective view seen through the lens of a camera, the vertical aerial photograph presents a truly vertical or undisplaced image only at the plumb point or nadir. Unless the terrain is absolutely smooth and flat, all other images pictured will be displaced toward or away from the nadir (Section 3). By contrast, a reliable planimetric map presents all features in their correct plan positions, and the observer sees each detail from a truly vertical view. The question thus arises, "When can photographs be used as map substitutes?"

While there are no absolute answers to the foregoing question, it may be generalized that individual photos are reasonable map substitutes when: (1) the aerial exposure is truly vertical, (2) the ground relief is minimal, and (3) the image scale can be accurately determined. When photographic flights are planned, image displacement (i.e., vertical exaggeration) can be purposely minimized over given terrain features by using cameras with long focal lengths. At any specified photo scale, for example, a 24-in. focal length will result in only one-half as much relief displacement as a 12-in. focal length, because the former exposures will be taken from twice the altitude of the latter. And high-altitude, vertical photographs over reasonably level terrain constitute fairly useful map approximations.

Where a number of individual exposures are to be used as map substitutes, it may be economically justifiable to have the prints *rectified* and/or *ratioed* by commercial firms. Rectified prints are those which have been corrected for tilt, while ratioed prints are those which are opti-

cally enlarged or reduced to a common image scale.

### Mosaics as Map Substitutes

As discussed in Section 1, a mosaic is an assembly of as many individual, vertical photographs as may be required to cover a specified area; they are usually constructed to provide a pictorial representation and a planimetric approximation of a fairly extensive ground area. The principal kinds of mosaics, in order of ascending scale reliability are: (1) index or uncontrolled mosaics, (2) semi-controlled mosaics, (3) controlled mosaics, and (4) orthophotomosaics.

The index mosaic is simply an assembly of untrimmed contact prints that are pasted up in overlap and sidelap positions so that image detail is matched and the original flight-line position of each exposure is reconstructed. The entire layout is usually rephotographed at a smaller scale for use as a pictorial reference to individual prints (fig. 4-1). An uncontrolled mosaic is assembled in a similar fashion (i.e., without ground control) except that each frame is first trimmed down to its "effective" or non-overlapping area. Then, each trimmed portion is matched together like the segments of a jigsaw puzzle.

A semi-controlled mosaic differs from the uncontrolled type in that it is assembled with the aid of limited ground control points. It is thus intermediate in scale reliability, depending somewhat on the local relief of the area depicted.

A controlled mosaic is one that is directly tied to an extensive network of ground control points, and it is usually assembled from prints

that are both rectified and ratioed. As a result, the mosaic will approximate planimetric map accuracy in regions of flat to gently rolling terrain. On the other hand, distortions due to relief are *not* eliminated in controlled mosaics, and *some* images will be displaced from their true plan positions.

An orthophotograph is a reproduction, prepared from ordinary perspective photographs, in which image displacements due to tilt and relief have been entirely removed. When these unique photographs are subsequently assembled into an orthophotomosaic, the result is a picture-map, i.e., a photograph with both scale and planimetric detail of high reliability. When such mosaics are overprinted onto standard mapping quadrangles, they are referred to as orthophotoquads (fig. 5-1).

## Existing Base Maps

When special-purpose maps are to be compiled from aerial photographs, a common procedure is to transfer the interpreted detail to a base map of known scale and reliability. Since the compilation of a completely new base map can be both tedious and expensive, an obvious alternative is to make use of *existing* maps that can be adjusted to the approximate scale of photography.

The various map series produced by the U.S. Geological Survey or the Canadian Department of Energy, Mines, and Resources often constitute excellent base maps that are available at a nominal cost (Section 4). County maps issued by various state agencies (*viz.*, highway departments) can also be utilized in many instances. And in those regions where lands are subdivided into townships and sections, rectangular township grids can be constructed from field notes available at county courthouses or state capitols.

Irrespective of the kind of base map chosen, large differences between photographic and map scales must be adjusted in some way. This is usually accomplished by optically enlarging or reducing the photographs to the scale of the base map, or by redrawing the map at the approximate photo scale.

## Use of Map Projections

For relatively small segments of the earth's surface, existing base maps can be enlarged or reduced without concern for minor distortions due to the earth's curvature. However, where large regions (e.g., entire states) are to be mapped, inherent distortions make it increasingly difficult to represent the earth's surface precisely on a flat map sheet. In such cases, it may be desirable to utilize (or construct) a suitable map projection as a means of alleviating the difficulty.

The principal projections used for various maps in the United States are:

1. **Lambert conformal conic:** used for sectional aeronautical charts, and for areas having their long axis running in an east-west direction.
2. **Polyconic:** used for most topographic quadrangle maps that are compiled by U.S. government agencies.
3. **Universal transverse Mercator:** used for many geographic referencing systems, military charts, and navigational purposes. This projection has gained in popularity and use over the past several years.

Map projections are referenced in terms of longitude and latitude; state grids and other coordinate systems (e.g., the UTM grid system) may also be marked along map margins for locational purposes (Plate 3). Details on the construction of various projections may be obtained from cartography textbooks and from U.S. government training/instructional manuals.

## Mapping by Radial Line Plots

A radial line plot is a triangulation procedure, adjusted by ground control points, whereby individual aerial exposures are correctly oriented and positioned in proper relationship with one another. The principle of radial line triangulation can be demonstrated with any two overlapping, vertical exposures. Straight lines drawn from the principal points (nadirs) of each photo through images of the *same object* will intersect at the correct horizontal position of the object, provided the prints are lapped in mosaic fashion with their corresponding flight lines superim-

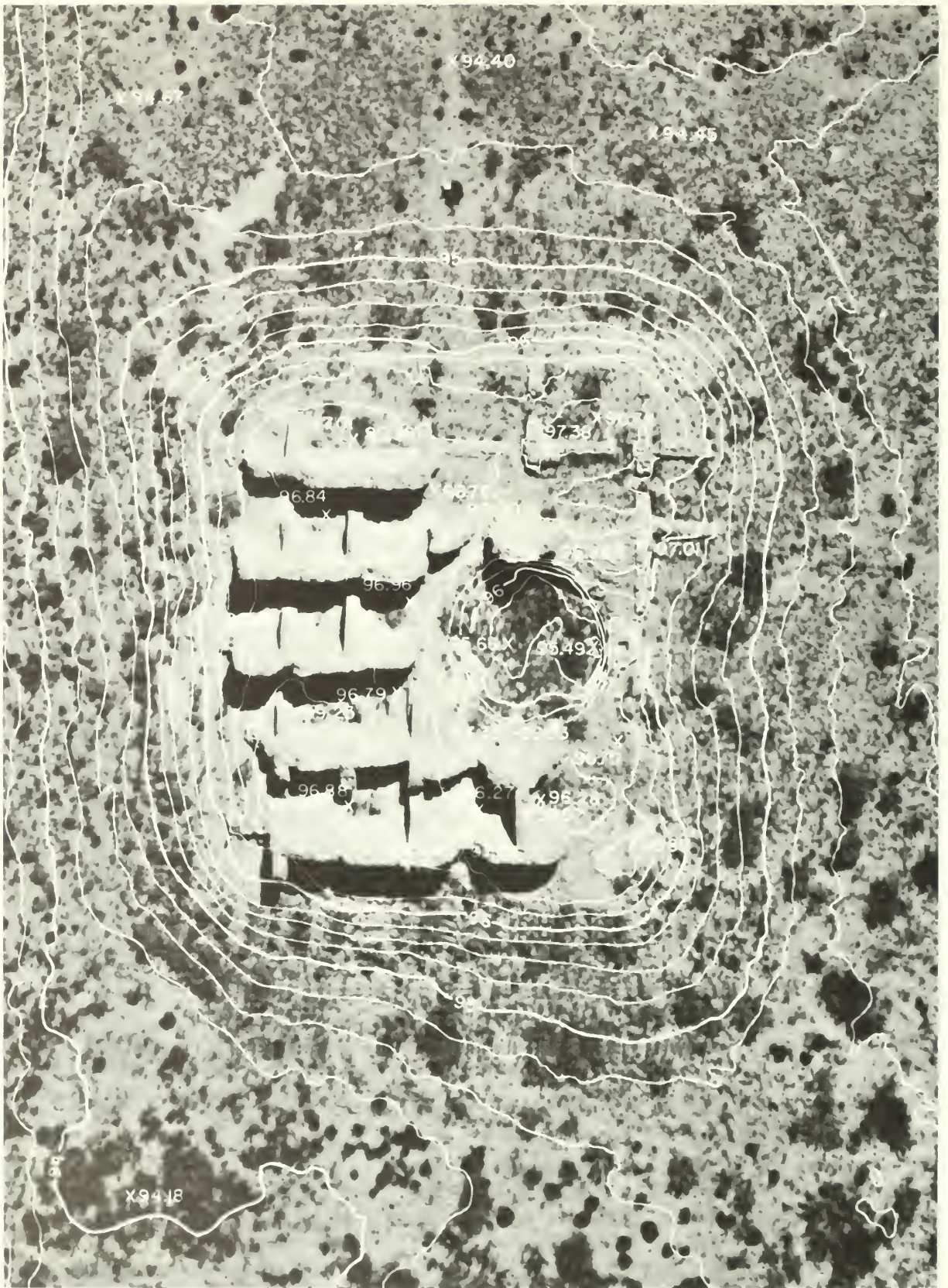

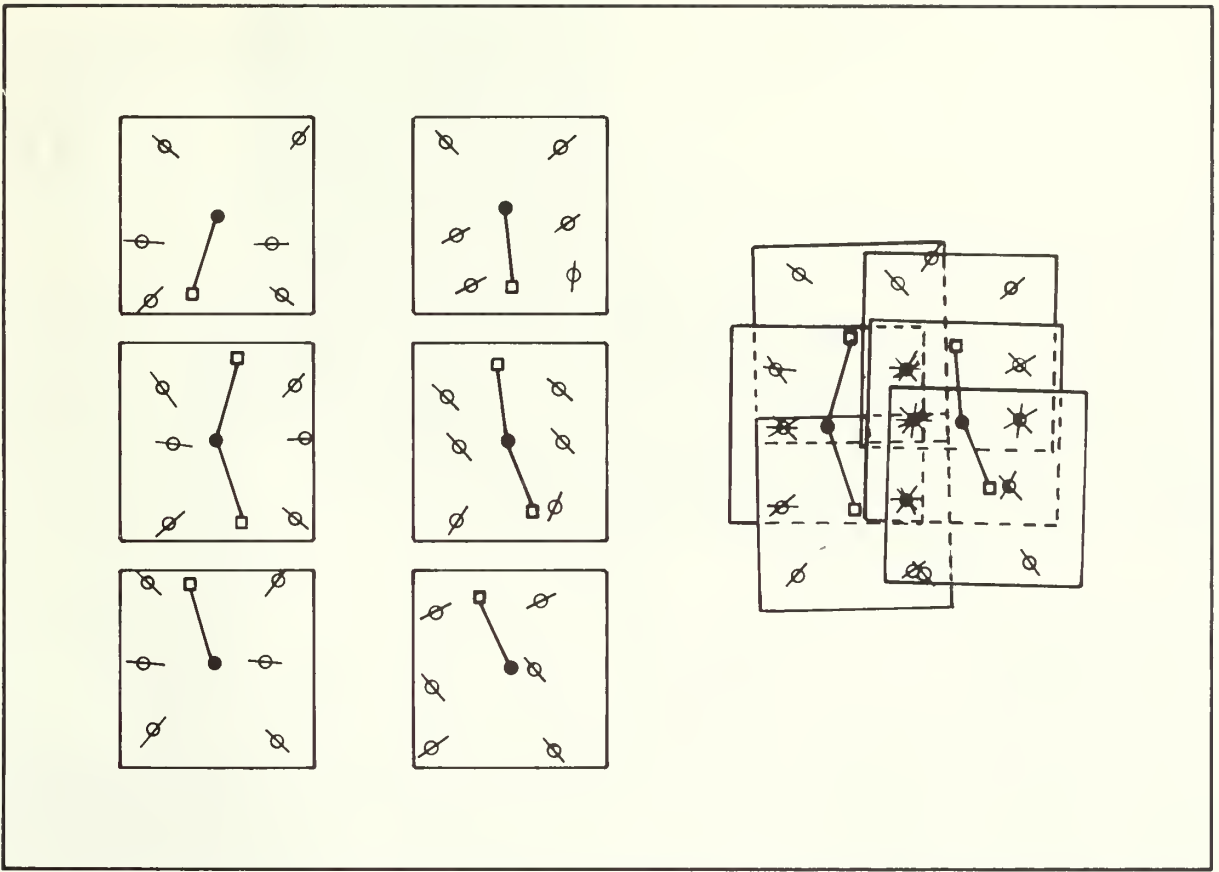

5-2 A schematic diagram of paper prints (left) and assembly into radial line plots (right). Reprinted by permission of Burgess Publishing Company. From *Interpretation of Aerial Photographs*, by Thomas Eugene Avery (1977).

5-1 An orthophotograph of New Alto in Chaco Canyon National Monument with superimposed topographic contours.

posed. By repeating this procedure for a network of control points on each photographic frame, an entire assembly of prints can be correctly oriented and tied to a base map (fig. 5-2).

A radial line plot does not eliminate image distortions due to relief displacement, but it does have the effect of averaging out the scale of an entire assembly of prints that span several flight lines. Once a radial line plot has been completed, the various points used for photo orientation and scale control are marked prominently on both the prints and the selected base map. This procedure permits the photographic imagery to be adjusted to the exact scale of the base map by simply matching up various combinations of corresponding control points.

## Photo Annotation and Delineation

Whenever feasible, photographic interpretation and the delineation of physical or cultural detail should be performed while viewing the prints stereoscopically. The greater clarity of detail provided by the third dimension is of invaluable assistance in the separation and recognition of many features.

Delineations of archeological features, physiography, vegetation, and soils can be drawn directly on prints under the stereoscope. As a rule, soft and bright-colored pencils are used for these annotations; colors such as yellow or magenta tend to show up most vividly. Paper prints

with a semi-glossy or semi-matte surface are the easiest to mark on with ordinary pencils. Where glossy prints and transparencies must be annotated, china-marking pencils will usually be preferred.

If several overlapping exposures are to be annotated, it is helpful to delineate the effective (non-overlapping) areas of *alternate* prints in each flight line *prior* to interpretation. In this way, annotations can be limited to every other print in each flight line — a technique that will simplify the later transfer of image detail with non-stereoscopic devices. If nine by nine in. prints have 60 percent endlap and 30 percent sidelap, alternate prints will have effective areas of about 6.3 by 7.2 in.

## Monocular Transfer of Photo Annotations

The transfer of photographic detail or delineations from single (nonstereoscopic) exposures can be accomplished by direct tracings or by use of specialized image-transfer devices. Tracing over a light table is efficient only when photographic and desired map overlay scales are essentially identical. One method reconciling minor scale differences is to construct two proportionate grid systems — one based on the average photo scale and the other based on the map scale. Since each grid is designed to cover the *same ground area*, the photo detail within each grid square can be ocularly transferred to the corresponding grid on the base map. This method will obviously work best where the photo scale is relatively uniform, i.e., in areas of gentle terrain.

Photogrammetric devices that are commonly used to transfer photo detail to base maps are of three general types: direct projectors, reflecting projectors, and camera lucidas. A basic example of the first type is to obtain or copy the annotated aerial imagery onto 35-mm. or 70-mm. positive transparencies; the imagery can then be enlarged to the map scale by using an ordinary slide projector. After photo and map are thus superimposed, the transfer of image detail becomes a simple tracing procedure.

Reflecting projectors are usually large, wall-mounted or table-top instruments that must be used under semi-dark conditions. Typical designs employ mirrors to reflect the photographic image through a lens system and onto a table top; thus their operation is somewhat analogous to that of photographic enlargers. Such devices offer a wide range of scale adjustments, but they tend to be non-portable and expensive.

Camera lucidas are devices that employ a semi-silvered mirror or prismatic “beam-splitter” that permits the viewer to see a reflected map and photographic image simultaneously. The photograph can be enlarged 1.5X to 2.0X with most camera lucidas to permit the matching of image detail to the exact map scale (fig. 5-3).

The greatest single disadvantage of the three transfer techniques discussed here is that only single exposures (monocular views) are seen by the observer. As a consequence, photos should be interpreted and annotated under the stereoscope prior to map-transfer operations.

## Stereoscopic Transfer of Photo Annotations

The simplest instruments designed for the stereoscopic transfer of photographic detail operate with paper prints that are assumed to be vertical exposures, i.e., those having less than one or two degrees of inherent tilt. Illustrative of this class of photogrammetric instruments is the Stereopret, a device built around a mirror stereoscope, an attached parallax device (stereometer) and a tracing pantograph (fig. 5-4).

In use, the floating mark of the Stereopret is adjusted within the stereo-model so that it lies in contact with the ground, or at the elevation of the detail to be transferred. Then, as delineations or images within the stereo-model are outlined with the floating mark, they are traced onto the base map through the pantograph linkage. The procedure is relatively simple, model setup time is minimal, and good results can be obtained when tilt-free photographs of gentle terrain are utilized. Comparable precision can be obtained with similar instruments from other manufacturers, of course.

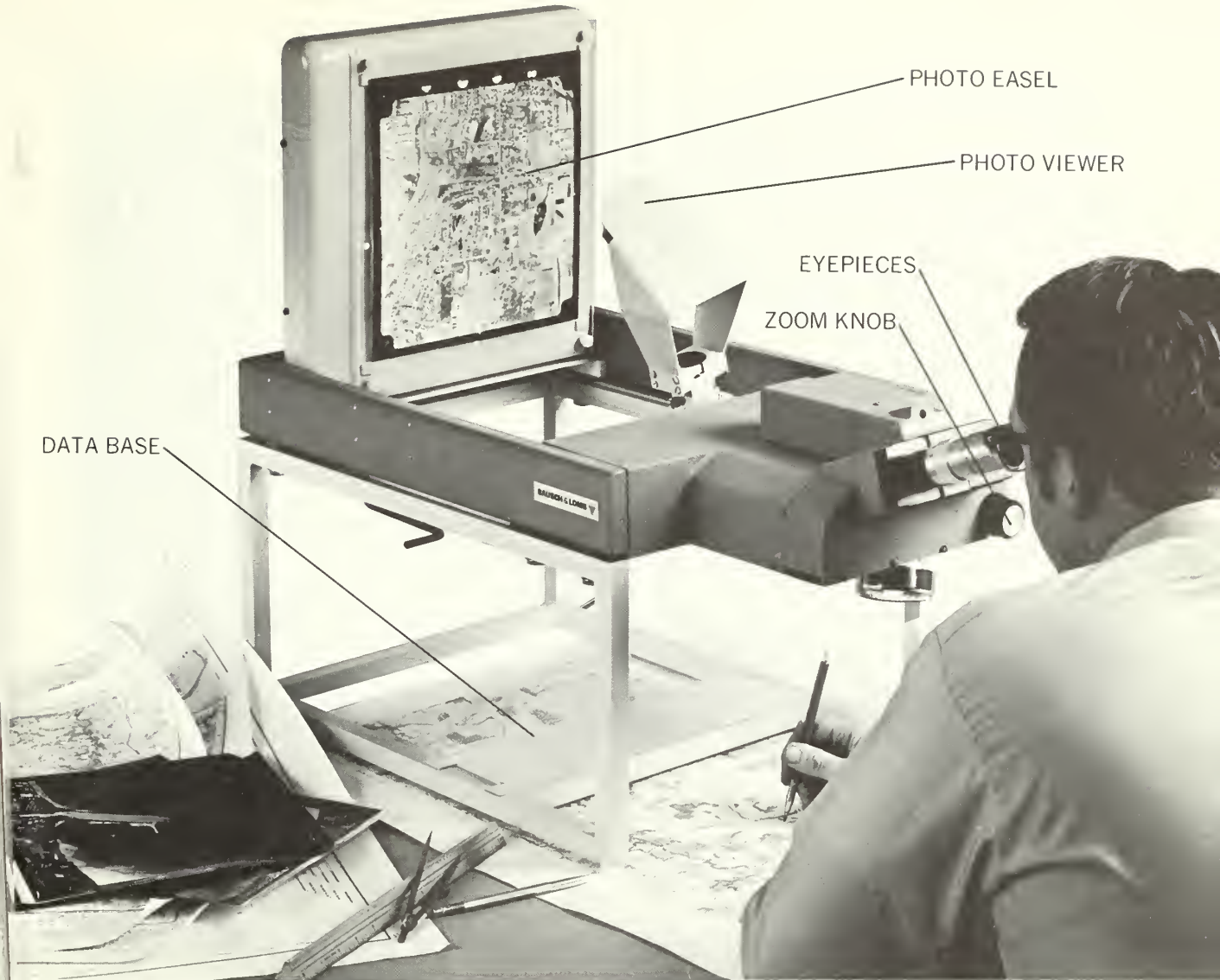

5-3 Zoom transfer scope, an instrument for transferring detail from single aerial photographs to base maps. *Courtesy Bausch and Lomb, Inc.*

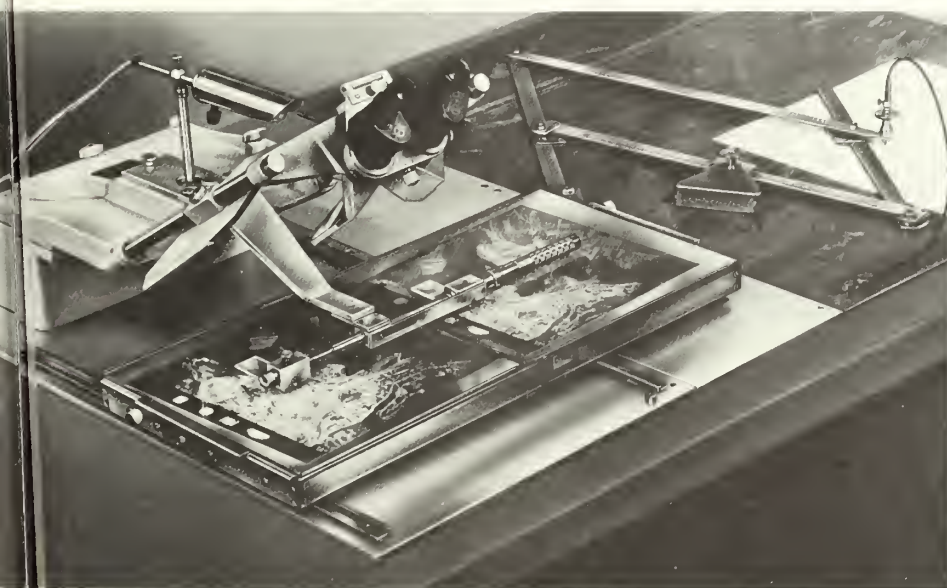

5-4 The Stereopret, a stereoscopic viewing and map transfer device. The system is based on a mirror stereoscope, stereometer, parallel-motion photo carriage, and tracing pantograph. Photo-scale adjustments range from 0.2X to 2.5X. *Courtesy Carl Zeiss, Oberkochen.*

## Form-Line Sketching

The preparation of precise topographic maps is not the usual objective of the photo interpreter-archeologist, but approximate contours or "form lines" can be sketched for small areas with simple, unsophisticated equipment. Form lines may be regarded as relative contours that are drawn to indicate general terrain conditions; they do not necessarily have uniform intervals nor represent exact elevations above sea level.

Basic equipment needed is a mirror stereoscope and a parallax device (stereometer) for determining ground elevational differences. The elevations of several points are measured within a stereo-model and referenced to the lowest point visible, e.g., the lowest water surface or deepest canyon. From the network of relative elevations thus established, approximate form lines are stereoscopically interpolated and sketched in by freehand techniques. With practice, skilled interpreters can differentiate form lines with intervals of 10 to 40 feet, depending on the image scale and amount of vertical exaggeration in the stereo-model.

## Topographic Map Compilation

Precision topographic maps are ordinarily compiled by commercial and governmental agencies that are equipped with complex stereo-plotters and staffed with highly skilled operators or stereo-compilers (fig. 5-5). The principal field work required is that of establishing a complete network of horizontal and vertical ground control to provide a basic framework and uniform scale for map compilation. This ground control also determines the accuracy with which planimetric detail and contours may be depicted and makes it possible to join maps of abutting quadrangles without a break in the continuity of plotted detail.

Ground control points are usually marked on the mapping photography and then tied to the preliminary base map (manuscript map) by the method of radial line triangulation. The scale of photography specified for a given mapping project is largely governed by the desired contour interval and the "contouring factor" (sometimes

called the C-factor) of the stereo-plotting instrument employed. The C-factor, multiplied by the least contour interval desired, determines the *maximum flight altitude* of photography that can be used for compiling contour maps of the specified accuracy. For example, if a plotter has an approximate C-factor of 1,200 and the desired contour interval is ten feet, the maximum flight altitude for the mapping photography would be  $1,200 \times 10 = 12,000$  feet above ground datum.

Most advanced stereo-plotters utilize glass diapositives made from aerial negatives in lieu of ordinary prints. When a given stereo-pair is placed in the instrument and correctly oriented to horizontal and vertical control, the three dimensional presentation of the exposure-overlap area is referred to as a stereo-model. The plotter operator moves a floating mark within this model to trace off planimetric detail and the specified contours. Completed manuscript maps are field-checked for errors and omissions; then they are ready for final drafting or "scribing", printing, and reproduction. Maps issued by the U.S. Geological Survey and similar agencies are compiled on a polyconic map projection and printed in four or five colors.



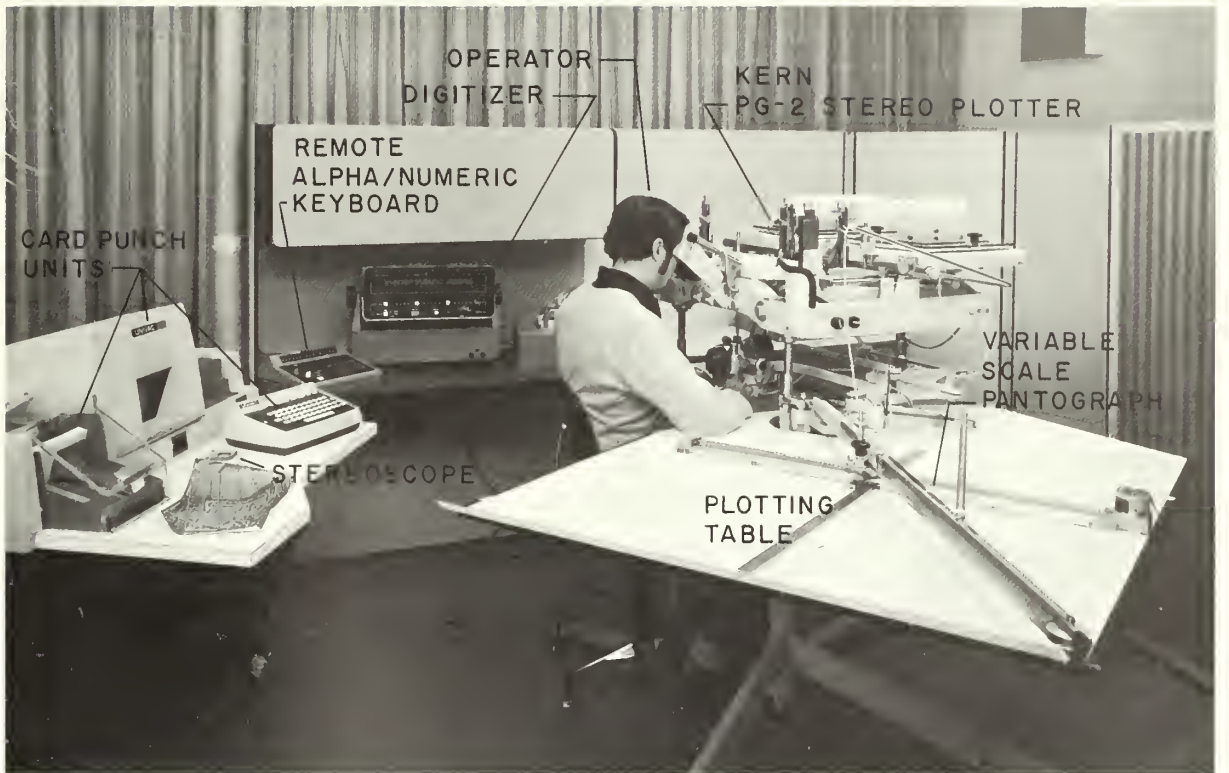

5-5 The Kern PG-2 plotter, a first-order instrument that employs the anaglyph principle to create a stereo-model of terrain features.

## Section 6

# Nonphotographic Sensors, Field and Laboratory Equipment

## Introduction

The abilities of the eye to see and the mind to interpret imaged phenomena are restricted because only limited portions of the electromagnetic spectrum are detectable, i.e., the visible and near visible ranges. Many natural and cultural phenomena not recognizable within these ranges can be identified, however, when their characteristic emissions from other regions of the electromagnetic spectrum are recorded. Many nonphotographic sensors are of this type and consist of those devices or instruments which record energies reflected or emitted from the earth's surface in either a pictorial or non-pictorial form without the use of optical lenses. Those instruments are described as "active" which generate and project energies and record reflected returns. Conversely, instruments which record naturally emitted or reflected energies are described as "passive".

The data gathered by either active or passive systems may be recorded on magnetic tape, viewed on a television monitor or cathode ray tube or converted into electrical impulses which in turn, through a photoelectric cell, expose a negative film thus producing an image of a target comparable to a photographic picture. Thus by means of the detection and measurement of radiation, much information can be obtained from the natural and cultural environments.

## Nonimaging Sensors

This group of sensing instruments measures the quantity and rate of radiant energies and

stores the recovered data in the form of traces such as an electrical resistivity curve or as data on magnetic tapes. A high degree of measurement accuracy is obtained but at the expense of a relatively low yield of information. This is evident when the data quantity from such systems is compared with the fund of data contained in a photo image. An advantage of these products, however, is their readily adaptable form for computer analysis.

There are several types of non-imaging instruments which are useful in archeological investigations. Non-imaging radar systems are employed to penetrate soils and rock in search of buried structures (fig. 6-1). Electrical resistivity devices and magnetometers have been successfully used for the same purposes.

Other non-imaging electromagnetic recorders include radiometers, spectrometers and scatterometers and are discussed in the technical supplement to this volume.

## Imaging Sensors

In addition to photography there are systems for sensing and recording radiations reflected or emitted from a target which convert the radiant energies into an image in which the eye recognizes visual forms. Such systems operate across that portion of the electromagnetic spectrum which includes the microwave, far and near infrared, visible and ultraviolet regions (fig. 6-2) and utilize video cameras, active radar and passive scanning instruments.

**Television** is one well-known system of this type, which, in comparison with the photographic system, has the advantage of viewing the

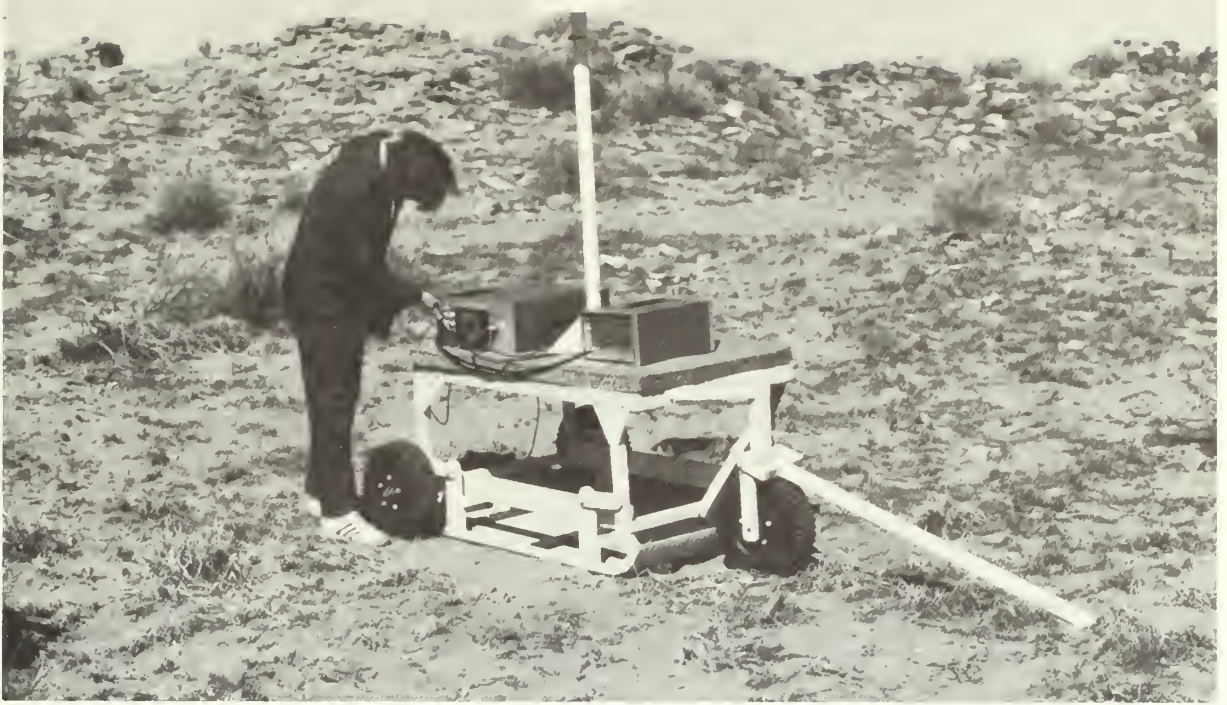

6-1 An active radar instrument with antennas on a hand-drawn cart. *Courtesy Stanford Research Institute.*

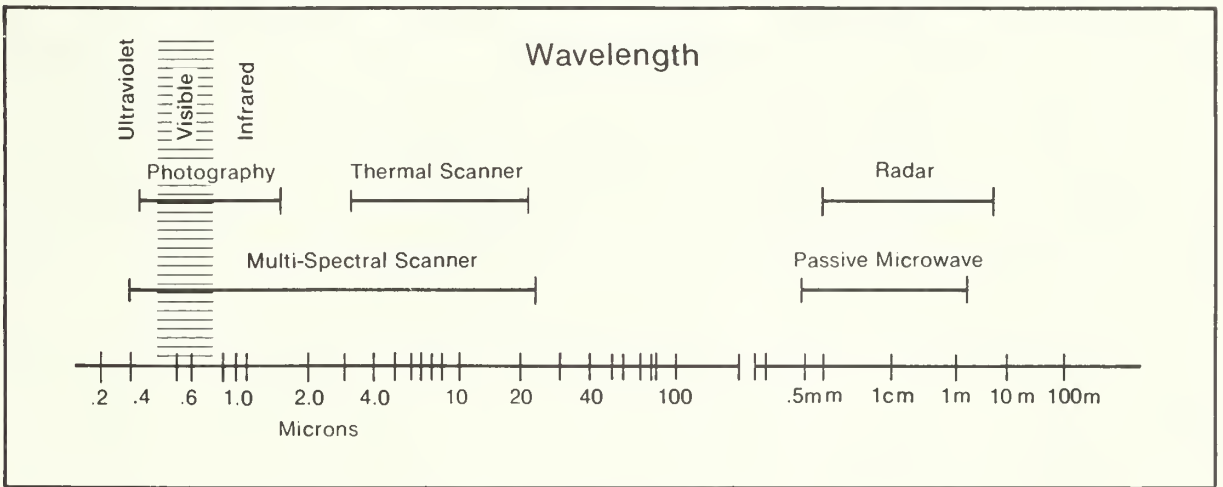

6-2 The electromagnetic spectrum—microwave to ultraviolet regions.

produced image in real time and of storing it on tape for later review. The spectral range covered by the video camera is approximately that of the photographic camera. However, the output has a much lower resolution than the photographic image. For cultural resource detection, the television system has the capability of portraying in sharp contrast, lineaments or alignments such as fence lines, wall traces, gridded field patterns,

roadways and the like. The television data output is in electrical form and consequently can be transmitted or can be recorded on tape or photographic film.

**Thermography**, or thermal infrared imagery, provides a representation of differences in object temperatures. Thermal radiations may result from the reflectance of solar energy or from internally generated heat. Whatever the cause, the

recording of the variable radiance can provide significant cultural resource information. Moist soils, for instance, have a greater capacity for heat radiation than dry soils and consequently contrasting patterns of emission. This contrast, then, results in spectral differences between old irrigation ditches, dormant springs, soil depressions and other like phenomena and the dryer surrounding areas (fig. 6-3).

**Multispectral scanning (MSS)** like multiband photography (see Section 1) is a tool of potentially great applicability to archeological studies.

The scanning instrument consists of an array of detectors each of which is designed to be responsive to different discrete portions of the electromagnetic spectrum. It thus provides synchronous filtered records of the object of study which reveal its different characteristics (fig. 6-4). Further, multispectral scanning lends itself to automatic methods of analysis and interpretation since it images a scene in several spectral regions and automatically makes these data comparable in terms of densities and patterns by specialized equipment.

6-3 An annotated thermal infrared aerial image of the Kin Bineola pueblo ruin and adjacent area in Chaco Canyon National Monument, New Mexico. Relatively warm areas appear in white and light shades.

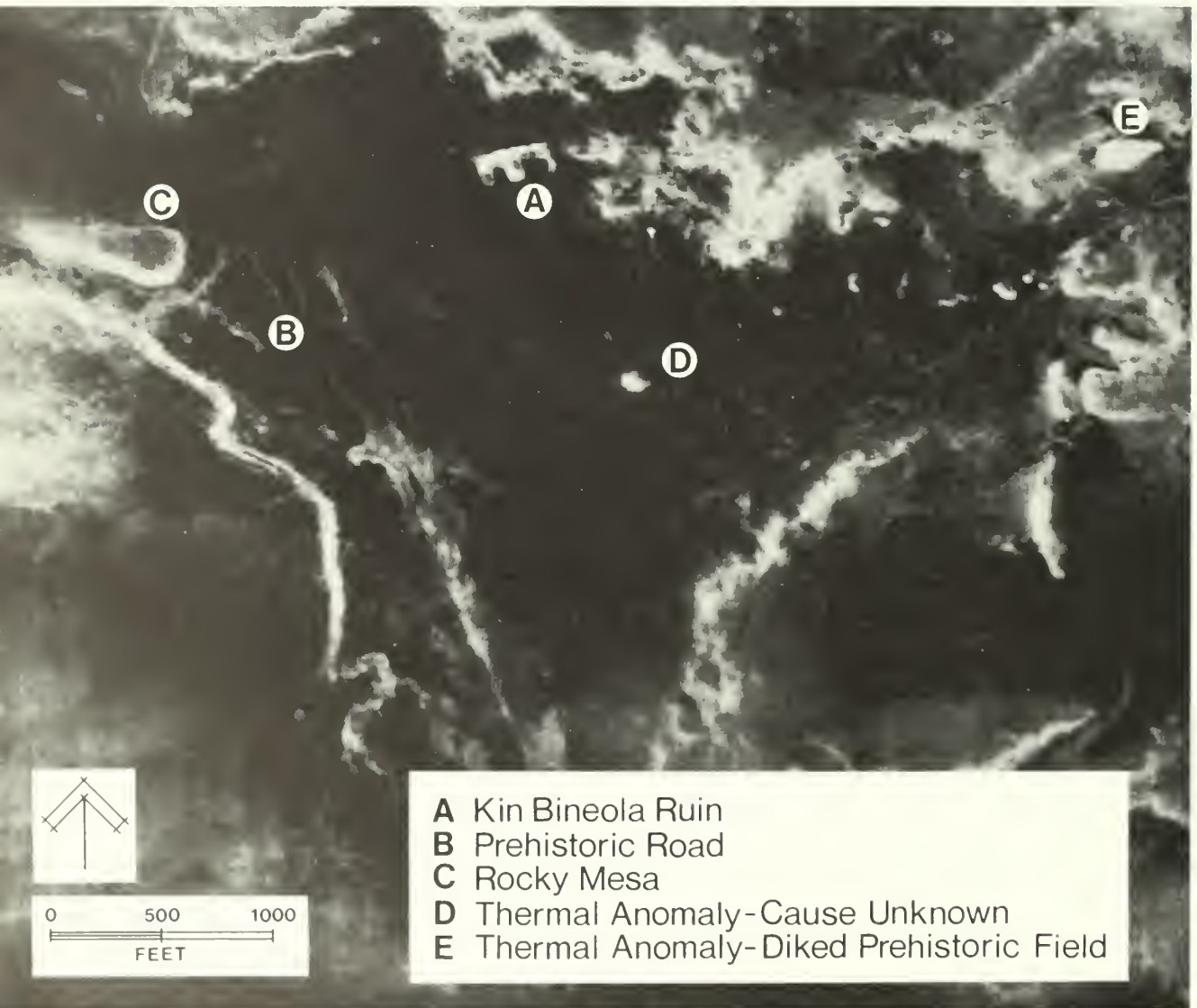

## Field Aids for Photointerpretation

The use of stereo pairs of aerial photography in the field is sometimes a trying experience. High winds and glaring sun are frequently encountered difficulties. Field kits have been devised which are quite helpful, and properly designed leather carrying cases for field equipment can be obtained from several manufacturing sources. The following are suggested items for inclusion in such a kit (fig. 6-5).

- pocket stereoscope or stereoscope lenses fitted to eyeglasses
- pocket stereoscope parallax bar
- various rules corresponding to the scale of the photographs
- lead and color pencils
- hinged metal plate, painted black
- six small magnets for securing prints on plates
- sharp stylus for pinpricking localities on prints

In addition, the individual interpreter will

6-4 A multispectral scanner (MSS) four-channel image from LANDSAT space craft of a large area in north-western New Mexico. This multispectral coverage provides the archeologist with information on environmental zones.

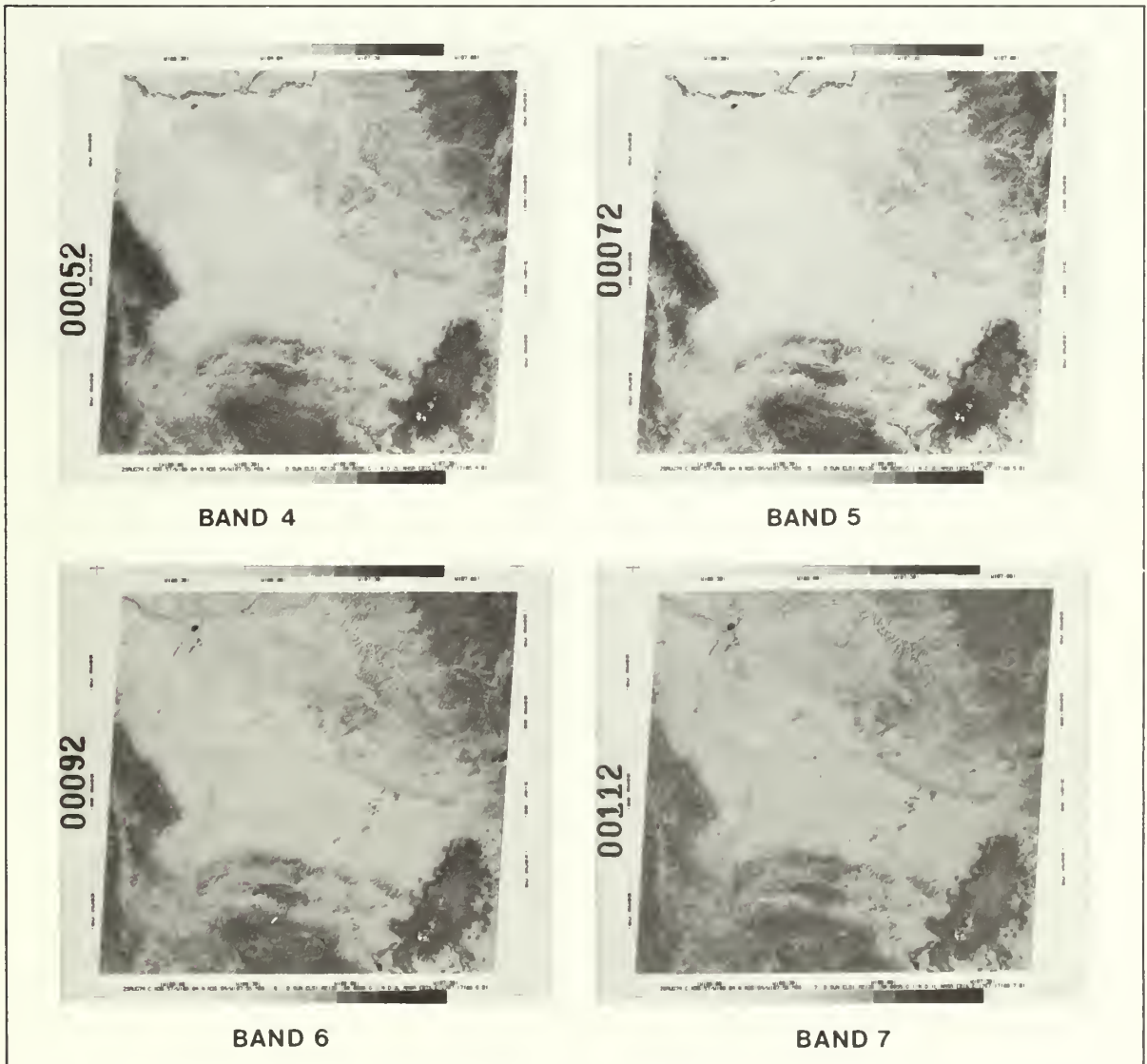

carry other items necessary or required for the specific field problem, e.g., camera, compass, notebook, etc.

6-5 Portable kit for interpreting aerial photographs in the field.



## Electronic Aids to Image Analysis

In addition to the instruments mentioned in Section 5 which are used principally for various kinds of mapping from aerial imagery, there are electronic devices, increasing in numbers and sophistication, designed for analytical use through image enhancement and isolation of image data. (See Instrumentation Supplement for further details).

### Additive Viewer

The multispectral additive viewer is one such instrument used for the analysis and interpretation of multiband or multispectral imagery. Normally this instrument consists of four or

more channels — each of which has a light intensity control and a blue, green, red, and infrared filter (fig. 6-6). There are various devices of this nature, and one standard type is able to handle four positive film chips or a roll of positive transparencies on which is a series of photos of a target taken with a four lens camera, each lens of which has been filtered to record data from different bands of the spectrum (fig. 6-7). The instrument has built-in x and y coordinate controls for the purpose of adjusting the positions of the images laterally and vertically into register.

With the aid of such a device and a developed skill of manipulating controls of light intensity and color filters, combinations can be portrayed on the screen which provide false color or infrared, natural color and other less conventional kinds of reproductions. In so doing, it is possible to isolate data of interest in the pictured



6-6 A multiadditive viewer for analysis of multiband imagery. *Courtesy International Imaging Systems.*

6-7 A four lens aerial multiband camera. *Courtesy International Imaging Systems.*

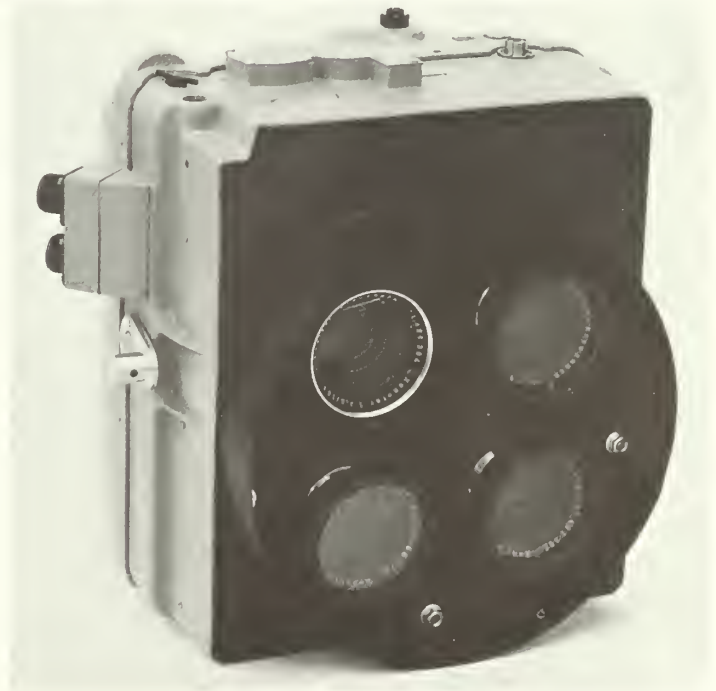

area: geological, biological, or cultural. Images derived from multispectral scanners can also be examined on this type of equipment.

### Closed Circuit Television Systems

Closed circuit television systems have been devised which possess a number of capabilities for image enhancement and data isolation. The system consists of a light table for positive or negative transparencies, a television camera which receives the transmitted light, and a series of screens or monitors which portray the information inherent in the image in different modes (fig. 6-8).

In this system, there is a color monitor which can portray on the screen one or more of thirty-two colors assigned arbitrarily to a density level or range within the viewed image. The

density levels or ranges thus identified are the responses to energies reflected or transmitted from the natural environment. A knowledge of ground conditions and ground checking as required will determine the nature of the observed phenomena, and consequently, it is possible to identify and map rock outcrops, plant communities, and man-made features of different types and age. The area of ground coverage and the density reading of each of the color bands portrayed on the monitor can be read out directly. (fig. 6-8).

Another element of this system is a black and white television monitor called an edge enhancer. Signals from the film transparencies on the light table are picked up by the camera and electronically reproduced within the system into positive and negative images which in turn are portrayed on the screen with slightly different degrees of offset. The net result is an image in which lineaments such as fence lines, railroad

6-8 A closed circuit television system with several image analysis capabilities. *International Imaging Systems.*

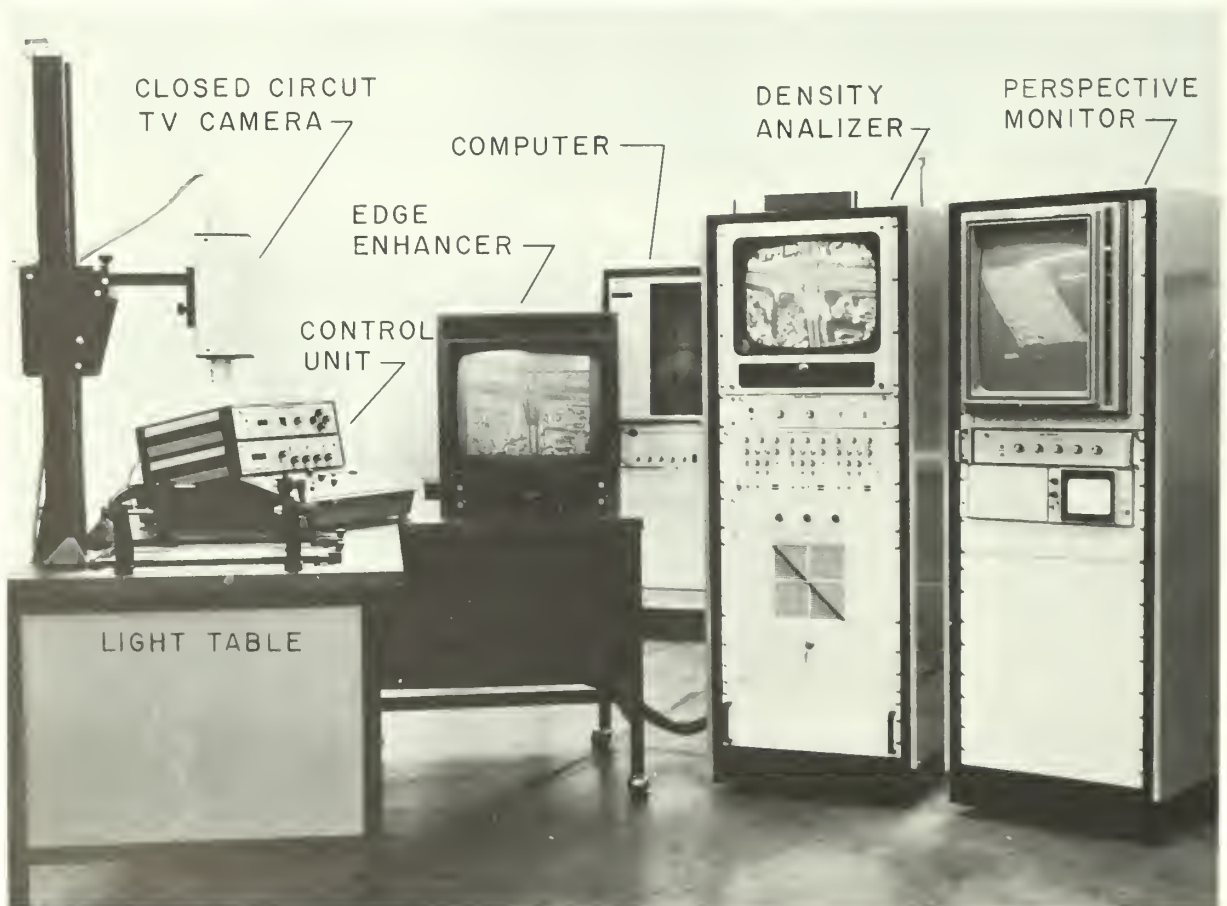



tracks, building walls, rock fractures, windrows and the like are visually enhanced (fig. 6-8). The scene can be viewed on this monitor as a simple black and white reproduction of the image or in various stages of the edge enhanced mode.

A monitor which presents a perspective view of the image on the light table is a third element in the system. The densities in the image are scanned and the resultant series of variable scan lines are portrayed on the monitor providing a perspective or apparent three-dimensional rendition of the subject (fig. 6-8). The perspective view can be rotated 360° or reversed so that elevated areas appear to be depressed and vice versa. This capability can be applied to topographic studies and the analysis of man-made structures.

### Integrated Television-Densitometer-Computer Systems

More sophisticated instruments are in use which possess the capability to digitize the densities of an image, and then combine these data with computer data handling and computer graphics capabilities for automatic data evaluation. Such instruments can use initially taped data generated by satellite multispectral scanners (fig. 6-9).

6-9 Schematic drawing of the integrated television-densitometer-computer system. *International Imaging Systems.*

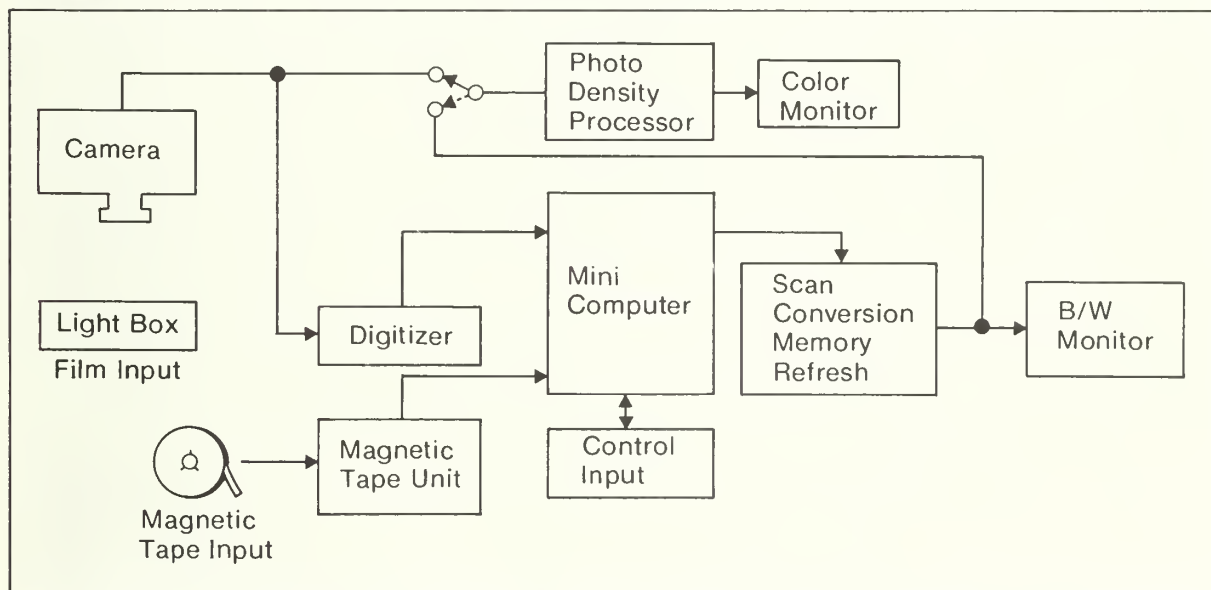

## Section 7

### General Interpretative Techniques

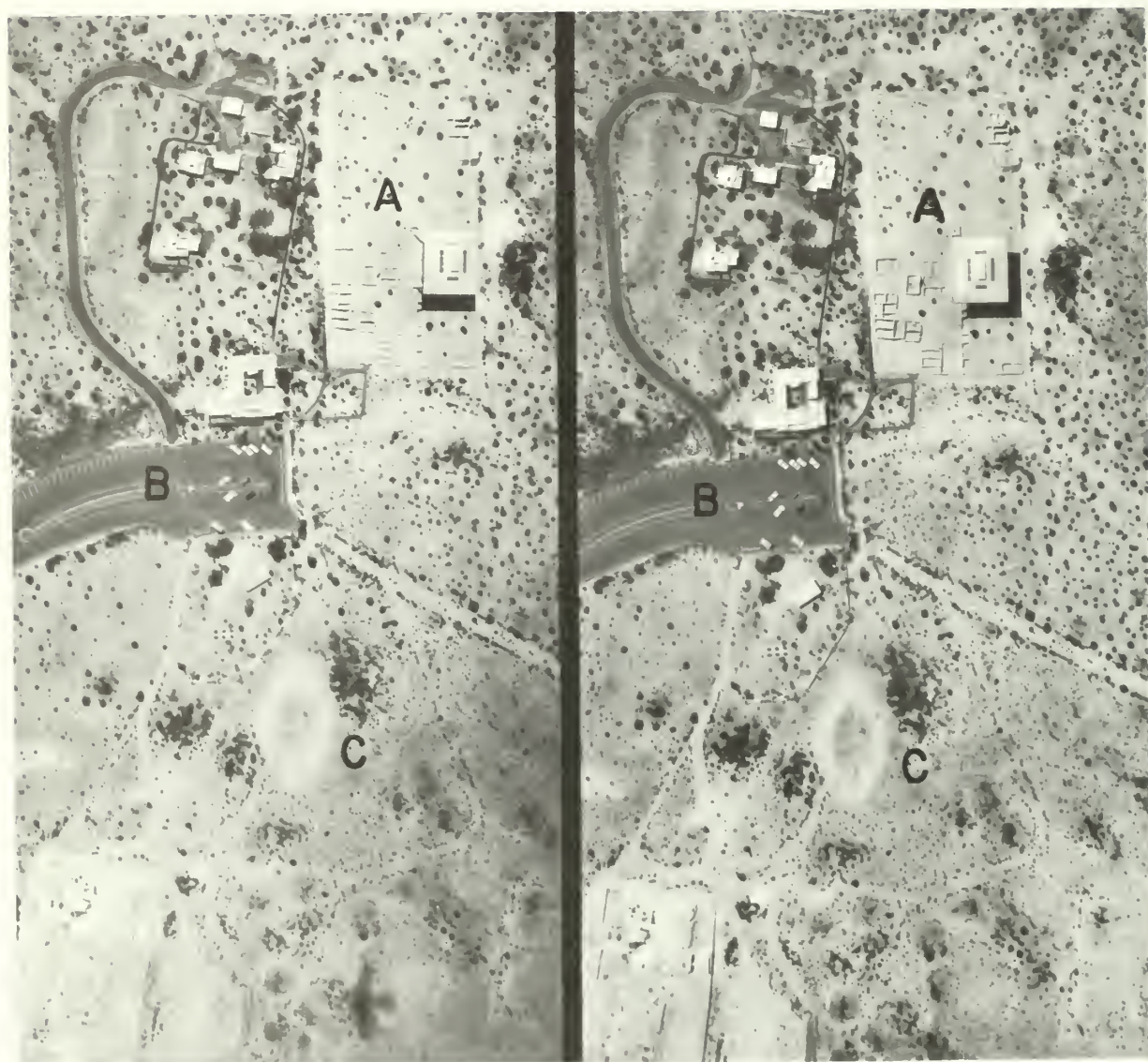

7-1 By the process of association, it may be inferred that the complex at "A" is an excavated archeological site and that "B" is a parking lot for visitors. When it is known that the site is located in southern Arizona, the feature at "C" would be interpreted as a ball court by an archeologist. Scale is 1:3000.

# What is Interpretation?

As mentioned in Section 2, photo interpretation is the art of identifying objects on aerial imagery, and determining the meaning or significance of those objects. For instance, if railroad tracks appear on opposite edges of an aerial photograph, the immediate recognition of the feature is an example of direct identification, a form of photo "reading". Conversely, if no tracks are visible across the *center* of the photograph, the presumption is that (1) both sets of tracks have terminated, or (2) a connecting link must exist in the form of a tunnel.

This chain of reasoning is a good example of *photo interpretation*, i.e., the probable identification of an unseen feature (the tunnel) by the mental process of logic and inference. This analogy is especially appropriate for archeologists, because they are often called upon to associate rather obscure clues in their searches for traces of buried or concealed sites.

Photographic interpretation may be defined as the recognition of objects that are imaged by remote sensors and the formulation of hypotheses or conclusions about the features of interest. The *mental* processes of association, logic and inference are often of greater significance than the visual processes. Two individuals may easily identify a surface mine, for example, but only the interpreter with a knowledge of the local geology and soils will be able to make valid inferences about the type and aggregate size of the extracted material. Similar inferences can be made from archeological data (fig. 7-1).

## Physical Attributes

It is obvious that image interpreters must possess a high degree of visual acuity. Specifically, they should have eyes of equal strength (or sight corrected by eyeglasses) so that they can develop a keen degree of stereovision. Individuals who discover that they have difficulty with the stereoscopic study of imagery are apt to be severely handicapped as interpreters. The continued emphasis on the use of aerial color imagery also makes normal color vision an essential physical attribute.

The complete evaluation of a person's visual perception is best performed by a professional ophthalmologist. However, there are several simple tests that can be administered in a laboratory with a minimum of equipment. Several government agencies and private corporations have devised simple tests that provide a measure of an individual's stereovision and depth perception (fig. 7-2). Similarly, the standard color test charts used by military recruiters can be employed to obtain a general indication of color perception.

It is worthy of mention that a much higher percentage of males than females tend to have deficiencies in color perception. As a rule, males also seem less adaptable to routine or repetitious tasks that require a high degree of patience and attention to minute detail. Consequently, females have assumed an integral role in diverse photo interpretation activities.

## Mental Attributes

The ideal interpreter is intelligent, imaginative, and has a high degree of learning capacity, patience, and judgment. Such persons also have an innate curiosity, along with a good memory retention regarding physical and cultural features that they have personally observed. As a result, they can often draw upon a personal experience or an innovative association in explaining the "how" or "why" of a feature seen on an aerial image.

If some of the desirable mental traits outlined here appear difficult to measure, it is also true that they are more-or-less ingrained or "imprinted" characteristics, i.e., they are *not* acquired as a result of on-the-job training. In brief, the best potential candidates as image interpreters are discovered and not made. A high I.Q. alone is not enough. Average intelligence, coupled with other characteristics, is a much better combination. Candidates with the desired mental traits, personality, and attitude can *then* be trained in the logic and technical aspects of image interpretation.

One simple evaluation of candidates' powers of observation and memory retention can be made by providing them with a block diagram showing outlines of the business structures on

X Y B O W U M Q P R C F  
 G J K Z V Q T G S A U M  
 B D F H H Z A R V Y E X  
 J F K L A W Q P N O O N  
 A D B N O N R O M E A L  
 P A S S W A R O P L M N  
 A D R E A G M R A E L E  
 M A R Q U E A B O U T A  
 A P O P R O F F E S Q Y  
 T H E R E I S H E R E J  
 A S A T H E R R O E S O  
 H I D D E N A M E S S A  
 M S O C C O A P E I O C  
 G E C A N Y O U R E A D  
 I T O P P E A R E N T S  
 S X Z W Y O Q P Z R Y L  
 C R E A P E T A I L O N

X Y B O W U M Q P R C F  
 G J K Z V Q T G S A U M  
 B D F H H Z A R V Y E X  
 J F K L A W Q P N O O N  
 A D B N O N R O M E A L  
 P A S S W A R O P L M N  
 A D R E A G M R A E L E  
 M A R Q U E A B O U T A  
 A P O P R O F F E S Q Y  
 T H E R E I S H E R E J  
 A S A T H E R R O E S O  
 H I D D E N A M E S S A  
 M S O C C O A P E I O C  
 G E C A N Y O U R E A D  
 I T O P P E A R E N T S  
 S X Z W Y O Q P Z R Y L  
 C R E A P E T A I L O N

7-2 A stereoscopic perception test.

7-3 A shopping center (B) and associated urban expansion are gradually eliminating such features as the agricultural lands and greenhouses (A). Older, single-family homes (C) are being replaced by apartments (D) and new residences (E). Location is Monroe County, N.Y. Scale is about 500 ft. per in.

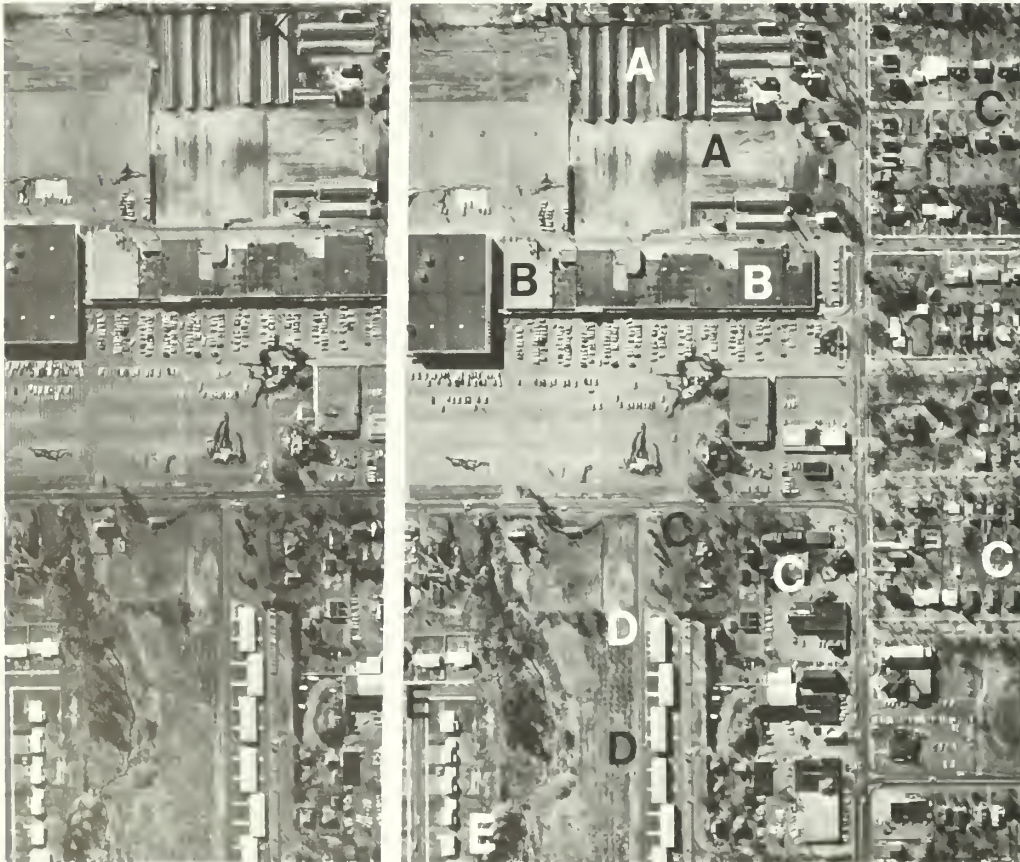

one block of Main Street (or a shopping center) in a locality where they have resided for a year or more. Those who can write in the identity of stores, banks, restaurants, etc. in the correct sequence have at least one attribute in their favor.

## Knowledge and Association

Another type of screening test might utilize a large-scale aerial photograph of a previously unseen shopping center (or similar feature). Here, candidates would attempt to *deduce* the business identifications (department stores, groceries, restaurants, etc.) from their own knowledge of the redundant nature of such features and their study of the relative locations, sizes of individual shops, parking patterns, and associated image details (fig. 7-3).

Interpreters that are expected to identify and evaluate physical and cultural patterns should have a sound knowledge of earth-surface features and the interrelationships of geology, soils, physiography, natural vegetation, and climate. Archeologists who can mentally correlate such environmental factors with past settlement patterns will have a decided edge as image interpreters. In fact, the ability to make inferences by associating acquired knowledge with what is seen on an aerial image is the hallmark of a skilled interpreter. As an example, the archeologist who understands how land elevation and precipitation tend to govern the distribution of vegetation in certain areas will be able to *predict* the kinds of plant communities that will likely be observed in a particular physiographic region.

## Interpretation Training

The development of skill and confidence in image interpretation is attained only by practice. The basic process is an iterative one: interpretation and ground verification, followed by more interpretation and additional field checking, etc. This learning pattern is essential, because persons who cannot identify an unfamiliar feature on the ground are even less likely to recognize it on a small-scale photograph. It should be emphasized here that remote sensing is *not* an alter-

native to archeological field work; it is an additional tool that can complement field examinations and assist in making more efficient use of time spent on sites (fig. 7-4).

Once an archeologist has acquired the basic skills of image interpretation, there are several kinds of aids available that may supply additional background knowledge for making associations and inferences. Such reference materials include various books written about the area of interest, existing maps on soils, geology, or vegetation, previous aerial imagery of the same area, and photo interpretation keys.

Comparative imagery, especially if acquired by a different sensor or during a different season, may enable the interpreter to detect otherwise unnoticed objects or activities, verify identifications, and establish approximate dates of activity. For example, features that may be easily seen and detected while under construction will be much harder to detect after the surrounding vegetation and landscape returns to a more normal condition.

## Interpretation Keys

Where available, image recognition keys can be a valuable adjunct to the self-instruction of neophyte interpreters. Image keys are most easily constructed and applied for man-made objects (e.g., transportation routes, industries, or ships) than for natural features. Nevertheless, there are some regional or local keys that provide aids to the identification of forest and rangeland vegetation, soils, or engineering construction materials.

Image recognition keys serve as: (1) a reference file for the trained interpreter, (2) a means of reducing the amount of field checking needed, (3) a method of ensuring some degree of consistency among different interpreters, and (4) a useful self-instructional device. The most valuable descriptive keys are accompanied by high-quality, annotated stereograms that provide visual comparisons with the imagery being analyzed.

The techniques and instrumentation involved in automated image interpretation are beyond the scope of this volume. Furthermore, while such techniques may be useful for simple land-use classifications (delineations of water, open lands, forests, etc.), they are more logically

applied to nonphotographic imagery than to standard aerial photographs. Basic photo interpretation and analysis are largely the output of human observation and inference.

7-4 Archeologist using an aerial photograph in the conduct of field examinations.

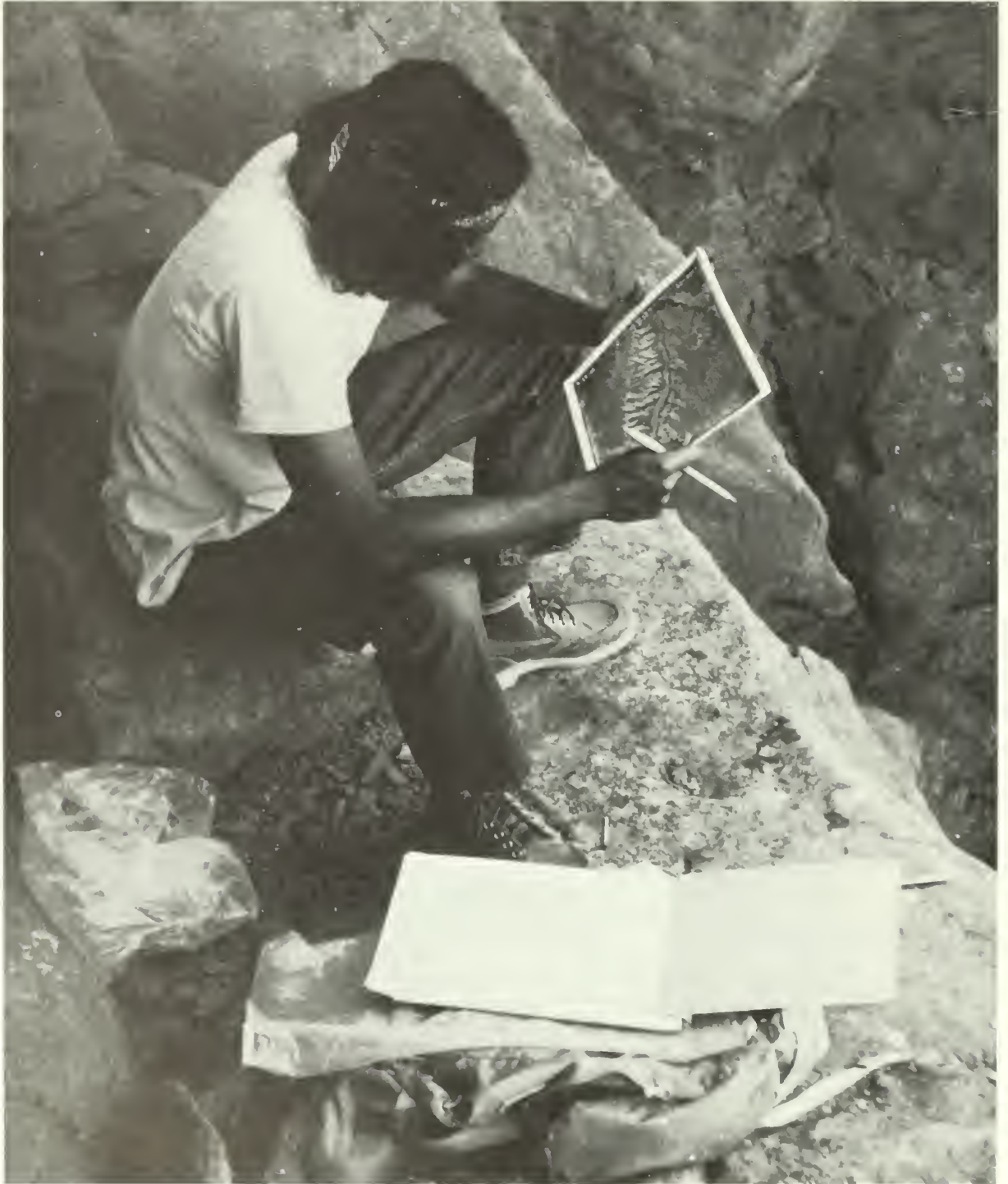

# Archeological Interpretation of Remote Sensor Data

## Introduction

Remote sensors on both aircraft and spacecraft provide a wide range and multitude of data in a uniquely compact form. This kind of agglomerated information lends itself, in terms of data type and quantity and of economy of handling to methods of archeological and related interdisciplinary research. Further, the synoptic overview obtained is the matrix of the observed cultural and environmental phenomena, that is, the context without which discrete phenomena can be described but not fully comprehended.

## Interpretation Skills

**Basic Skills.** Skills for the interpretation of remote sensor data among archeologists, as with others, is both inherent and acquired (see Section 7). Familiarity with the instrumental aids available to the interpreter is required as well as the physical and mental ability to read and study remote sensor data. The observer must cultivate the ability to correlate imaged data with environmental identities, to evaluate the cultural landscape and to apply derived information to the resolution of defined archeological problems. Thus, the improvement of inherent skills and the development of acquired skills are the goals of the archeological interpreter.

**Field Situations.** Wherever and whenever possible, a first hand knowledge of actual ground conditions in a study area should be acquired to provide a reference base for image interpretation. Familiarity with the landforms, erosion

processes, and climatic variables enable the interpreter to make many significant discriminations. It follows, of course, that a knowledge of the cultural configurations and time depth is invaluable to the archeological interpreter as well as field experience with soils and stratigraphic units which contain cultural materials. Such information enables him to mark distinctions between natural and human phenomena, between prehistoric, historic and modern cultural features and resources.

**Image reading skills** are the first requirement and consist, simply, of the ability to recognize and identify patterns within the image. Although much information can be acquired by studying single frames of imagery, much more can be derived from stereo pairs.

In order to interpret data, both inductive and deductive evaluations of apparent configurations must be made. To do this, a recognition pattern is to be developed using keys as described in Section 7.

A recognition pattern is defined as the interpretative tool which enables the investigator to relate an imaged pattern to its true identity. This requires the capability for stereoscopic vision and for relating a vertical perspective to the more normal horizontal or high oblique perspective. Another element of the recognition pattern normal to the individual is his background and experience in terms of education and familiarity with urban and rural areas and physiographic regions. Elements of the recognition pattern which the archeological interpreter must learn to recognize are shadow, crop, soil and snow marks discussed below. Further, the ability to differentiate between various types of lineaments is important to him since so much of modern

and prehistoric man's constructs are characterized by lineal geometry: architecture, roadway, gridded fields and the like. There are numerous forms of lineaments which must be recognized—rock fractures or joints, faults, some stream channels, etc.

When such learned skills are fully developed, the interpreter will be able to differentiate between cultural and environmental phenomena, to determine relative age of natural and cultural features in some instances, to recognize spacial relationships. In a word, he will see both the forest and the trees.

*Familiarity with equipment and instruments* used in remote sensing is a requirement for the investigative archeologist. As discussed in Section 2, the basic tool of the interpreter of remote sensor imagery is the stereoscope, either the pocket or mirror type. By far the greatest percentage of interpretative work is done with the stereoscope using stereo pairs or models of aerial photography. Stereo plotting devices also employ the stereo models for archeological purposes and provide many clues for the interpreter. Planimetric maps and topographic contours of a desired contour interval furnish a great deal of environmental information for an archeological study. In addition, architectural sites, both before and after excavation, can be mapped and much information normally lost in the destructive process of archeological digs can thus be retained (fig. 8-1). Archeological surveys can be made with the aid of a stereoplotter, and significantly large samples of the cultural resources within surveyed areas can frequently be identified and recorded in this manner (fig. 8-2).

Electronic aids, which have been discussed briefly in Section 6 enable the interpreter to isolate and manipulate data inherent in an image in order to achieve a desired result of site discovery and evaluation or environmental analysis. Some lineal features such as prehistoric roadways are for the most part invisible from a ground vantage point but appear as faint lines on some aerial photography (fig. 8-3). When this imagery is edge enhanced, many additional segments of the faint alignments appear.

Density slicing instruments aid in the study of environmental phenomena. For instance, physiographic features, floral communities, bare soils and rock outcrops can be differentiated and

their ecological relationships studied. Both density slicing and edge enhancing techniques are used in analyzing large culturally disturbed areas in the environment. Differing plant community patterns and alignments of subsoil structures can be brought into sharp contrast and more information often gained by this procedure than by visual scan (Plate 4 and fig. 8-4).

## Field Methods of Remote Sensing Site Survey

The scope of remote sensing research in archeology includes not only identification and location of cultural features but the environmental facts that relate to such manifestations. A site or a group of sites is studied in its geographic setting which may encompass scores or even hundreds of square miles. Traditional methods of ground investigations of such large regions can be thorough and exhaustive. But they can also be prohibitively expensive and time consuming. However, the sweep of aerospace perspectives provides a vantage point for rapid data gathering and economical interpretation, evaluation, and reporting. An example of this is archeological site surveying methods utilizing several remote sensing techniques.

The first use of aerial photography, for instance, in archeological survey is frequently as field mobility maps. Such use has traditionally been made of aerial photography by virtually all disciplines dealing in natural sciences. Ecological elements are important to the archeological surveyor and can often be identified and mapped with speed and precision on aerial photographs. These include the physiographic elements of terraces, bajadas, mesas, benches, canyons, hills, mountains and other ecological elements such as plant communities, bodies of water, soils, and the like.





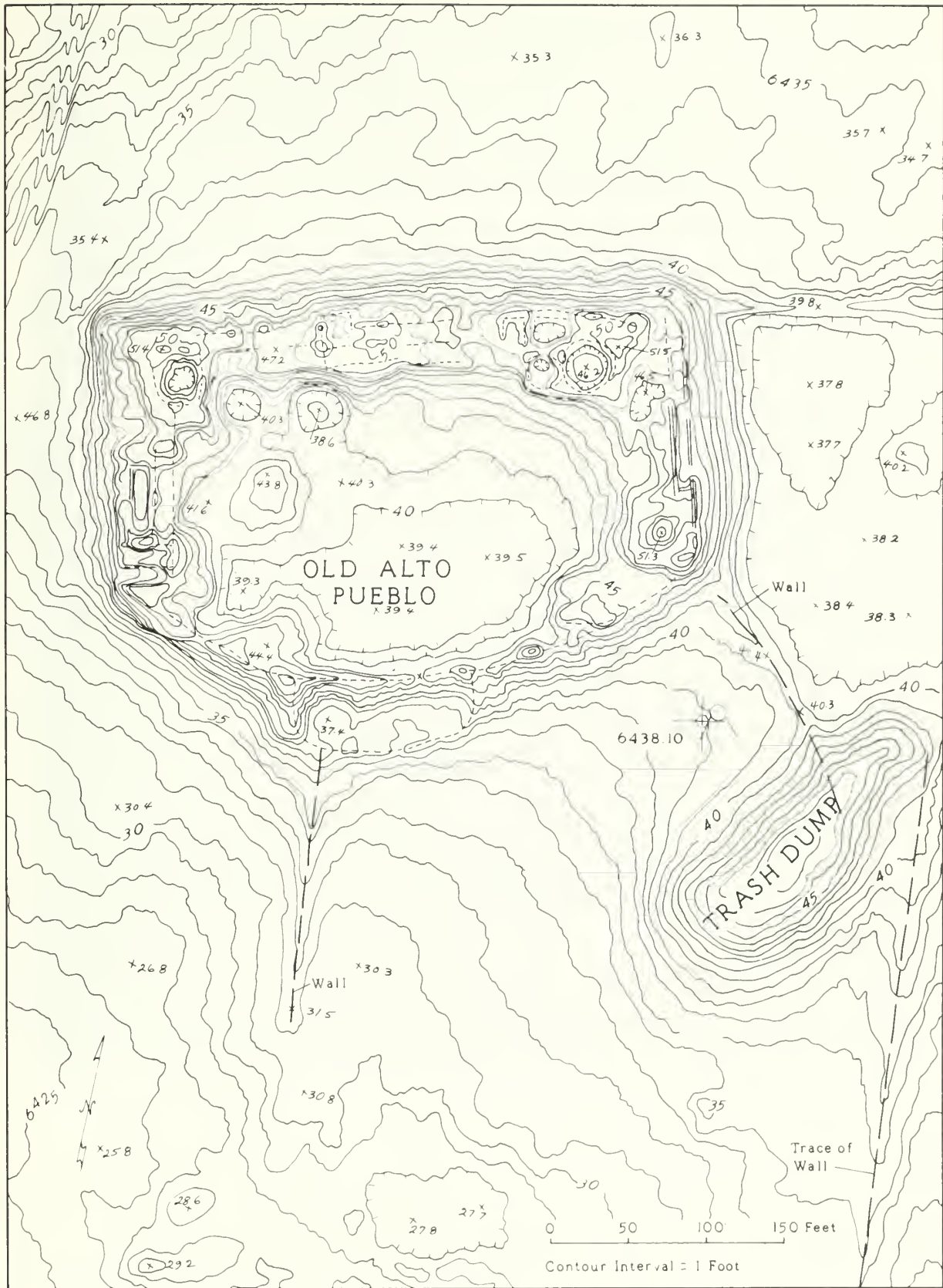

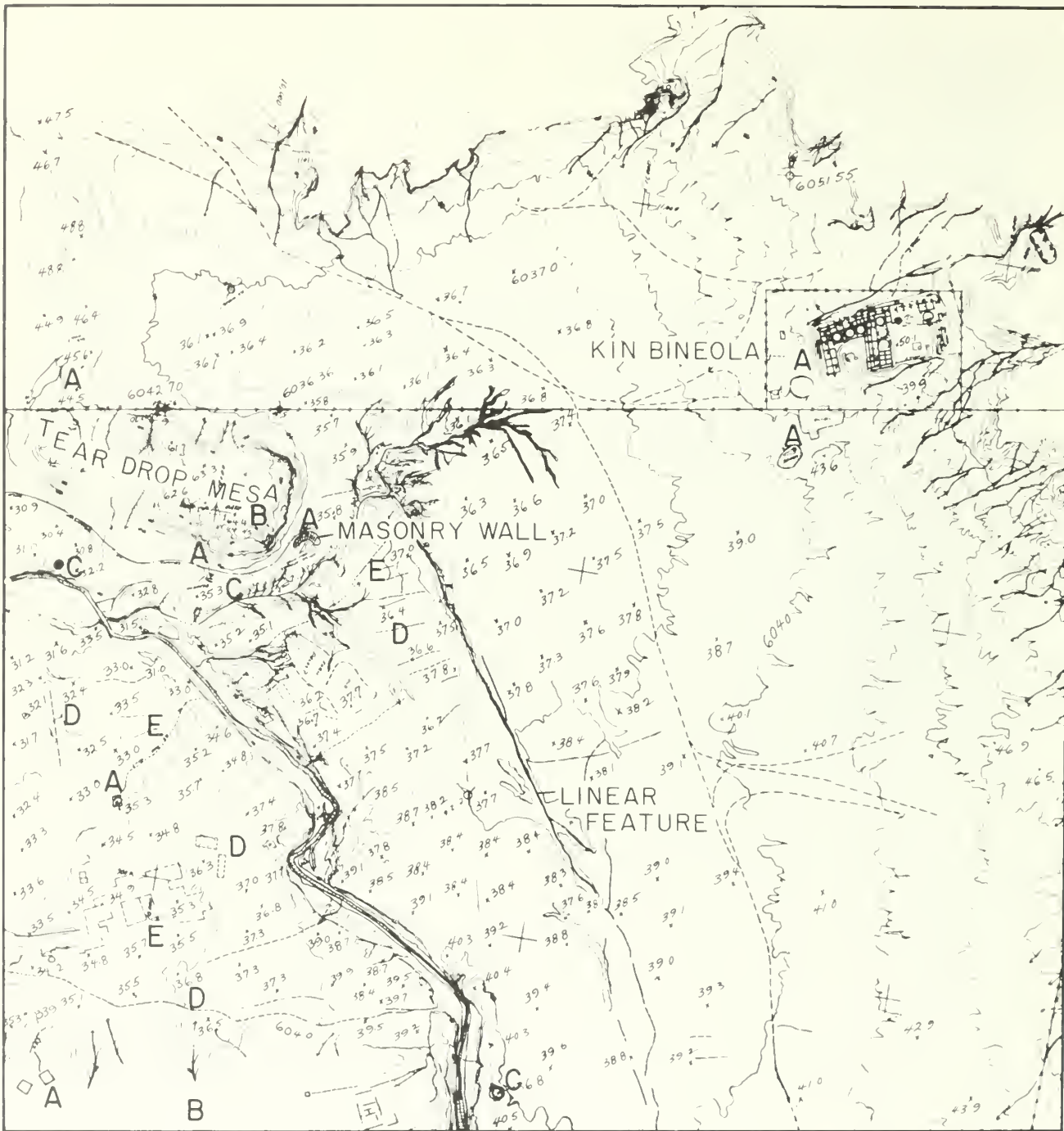



**8-1** A photogrammetric manuscript map of the Pueblo Alto Site, Chaco Canyon National Monument, before excavation, showing walls, trash dump, depressions, elevations, and terrain slope.







### LEGEND

- |   |                                     |   |   |   |
|---|-------------------------------------|---|---|---|
|  | Modern Vehicular Road               |  | A | Archaeological features located by photo interpretation and confirmed by surface survey |
|  | Barbed Wire Fence Line              |  | B | Historic features not located by photo interpretation but located by surface survey     |
|  | Vertical Control Point              |  | C | Cultural anomalies located by photo interpretation and identified by surface survey     |
|  | Horizontal & Vertical Control Point |  | D | Natural anomalies located by photo interpretation and identified by surface survey      |
|  | Contour Interval = 2 ft             |  | E | Anomaly located by photo interpretation but not recognizable in the ground              |
- 0 100 200 300 Feet

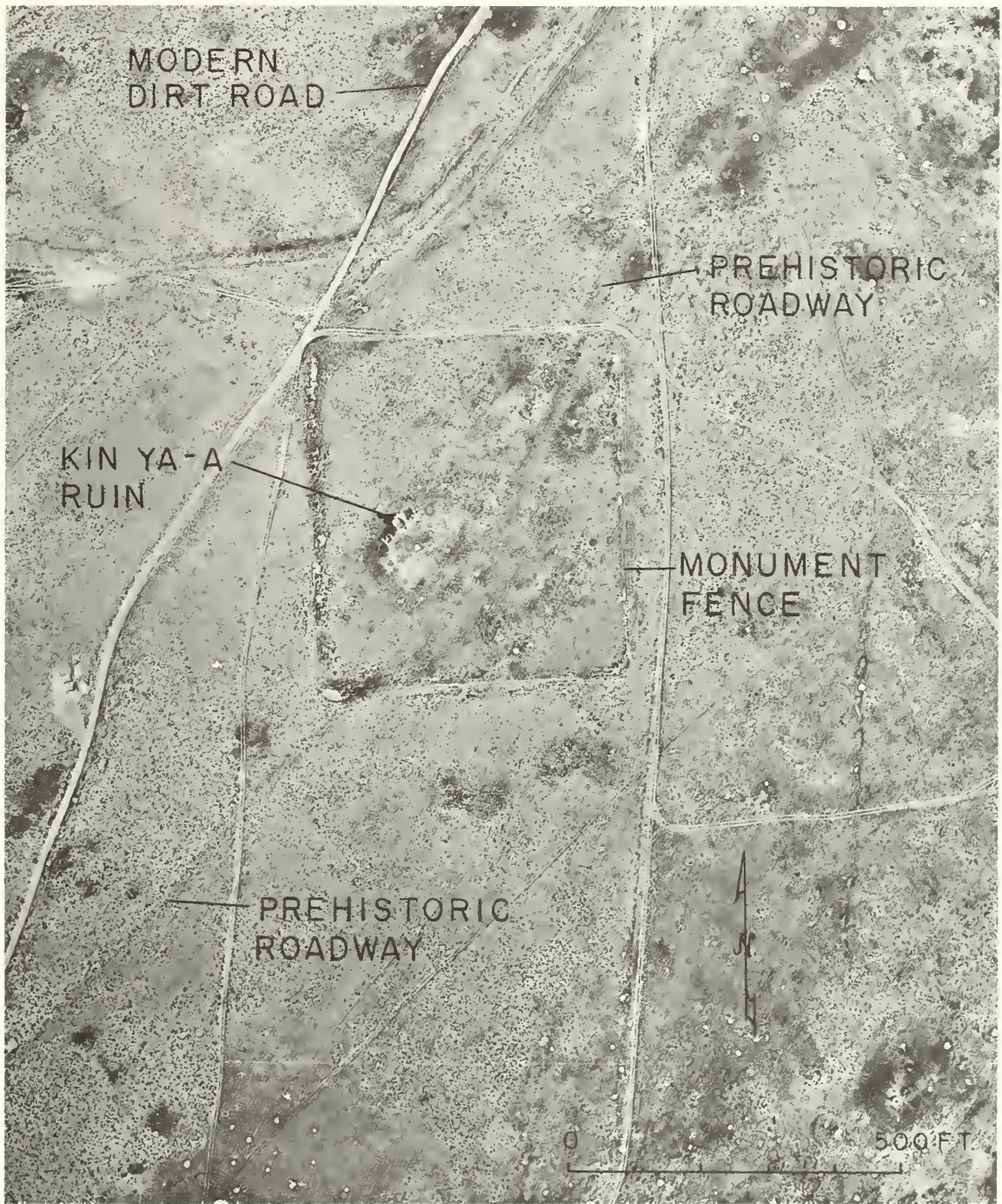

8-3 A vertical black and white aerial photograph of the Anasazi pueblo ruin of Kin Ya'a, Chaco Canyon National Monument, with prehistoric roadways identified.

8-2 A section of a photogrammetric manuscript map of the Kin Bineola Ruin area, Chaco Canyon National Monument, with archeological and natural anomalies identified.

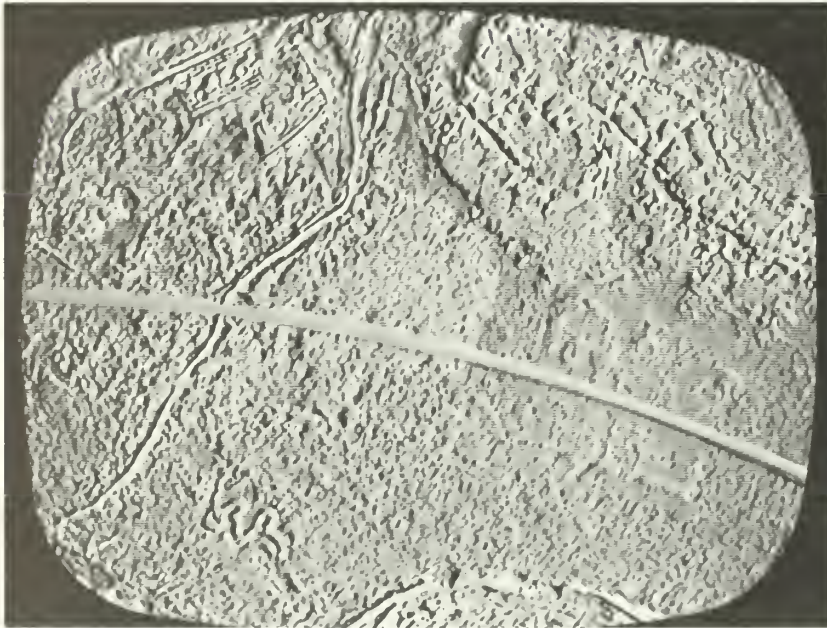
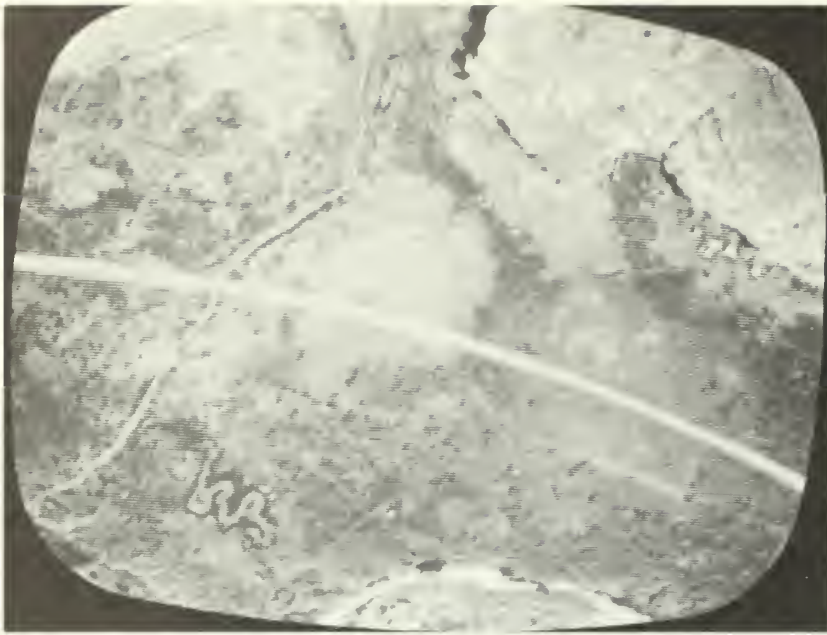

8-4 The same field portrayed in Plate 4 as seen on a black and white TV monitor (above) and an edge-enhancer monitor (below).

Archeological sites which are discovered during ground surveys are readily identified and plotted on aerial photography of a usable scale whether or not the site itself is visible on the image. This site identification and location on the photography is done by first of all finding oneself on a highly visible spot in the photograph—by a prominent tree or rock for instance—and using this as a reference point for

locating the site. Best results are obtained with the use of stereo pairs. When the site location is determined, its position is pricked on the photo with a stylus, circled and identified with its field number and later plotted on a mosaic or topographic map of the surveyed area. Semicon-trolled mosaics of many areas in the United States are available as explained in Section 4. After site locations are transferred to the mosa-

ics, overlay maps of their locations and ecological setting are easily traced. The sites are then positioned with sufficient accuracy for the study of relationships and distribution and for eventual relocation if necessary.

## An Approach to Site Discovery

Although some archeological sites are discovered purely by accident, there are systematic means of searching for and finding sites in any environmental region. Mankind's own brief recorded history provides many clues into past settlement patterns and activities of earlier civilizations. The various factors that led ancient peoples to select particular sites for their villages, forts, and burial grounds are still determinant forces today. This governing principle is especially apparent among agrarian, non-industrialized societies.

In aboriginal or tribal communities, the essential elements for the survival and perpetuation of a society were about the same as they are now:

1. A reliable source of water
2. A means of finding game and edible wild plants, or the capability of growing food crops
3. Shelter from the elements and protection from enemies
4. Land or water access routes for transporting essentials to a selected habitation site
5. A favorable climate, i.e., acceptable in relation to other alternatives known to be available.

If a given physiographic region is systematically surveyed with the foregoing criteria in mind, it will become apparent where the most hospitable habitation areas are situated. As a minimum, the search can be appreciably narrowed by applying these controlling factors in a "convergence of evidence".

It will be recognized that most of the controlling elements of human environments can be identified or inferred from the study of aerial photographs and/or nonphotographic imagery. Since the availability of water is the most critical requirement for large or advanced habitation

sites, preliminary searches should be concentrated near perennial streams and lakes. The hierarchical ranking of the other controls must be established on the basis of local considerations, because their relative importance will vary from one archeological period or physiographic region to another. The use of aerial imagery, coupled with a well-conceived search rationale such as that outlined here, can greatly improve the chances for site detection in relatively unexplored regions.

In a world faced with an ever-increasing population and accompanying food shortages, the unearthing of ancient civilizations can produce significant benefits to those who struggle for survival today. For example, the discovery of once-arable lands that supported earlier peoples may provide us with new insights on living in harmony with near-hostile environments. We can also derive valuable information on what *not* to do, *if* we are receptive to the lessons of history. There are numerous cases where formerly lush rangelands have been completely denuded by overgrazing. The signs are clear for those who can learn by observation.

## Site Detection from Plant Marks

Faint indications of buried or obscured sites are sometimes directly discernible on aerial imagery. Subtle outlines of ancient features may be produced by plant-growth anomalies, soil variations, or shadow patterns. Unfortunately, these faint delineations may be registered only at certain times of the day or during limited seasons of the year.

Differences in the color, density, or height of agricultural crops or grasslands will sometimes provide a clue to the existence of buried landscapes. And, the occurrence of different or unusual tree and shrub species may furnish additional evidence of subsurface features. A common explanation for these anomalies in plant growth is that the upper soil horizon has been disturbed and is no longer uniform, i.e., the zone of cultivation has become more fertile or less fertile due to subsurface changes. Consequently, plant growth directly above the affected areas will be either superior or inferior compared to that on uniform, undisturbed soils.

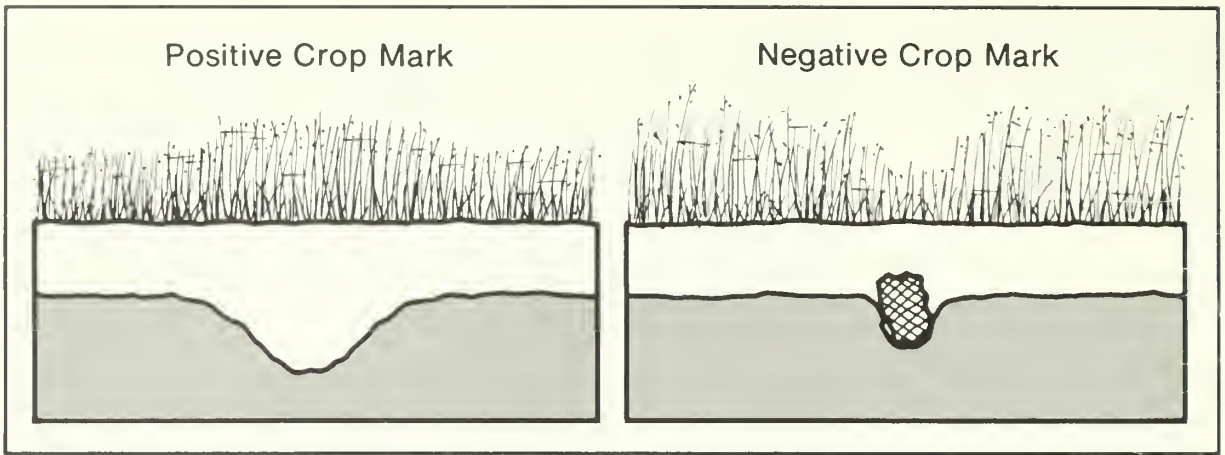

8-5 A schematic diagram of positive crop marks (left) and negative crop marks (right).

8-6 A terrain profile (above) showing how soil marks are produced with a vertical view of similar terrain (below).

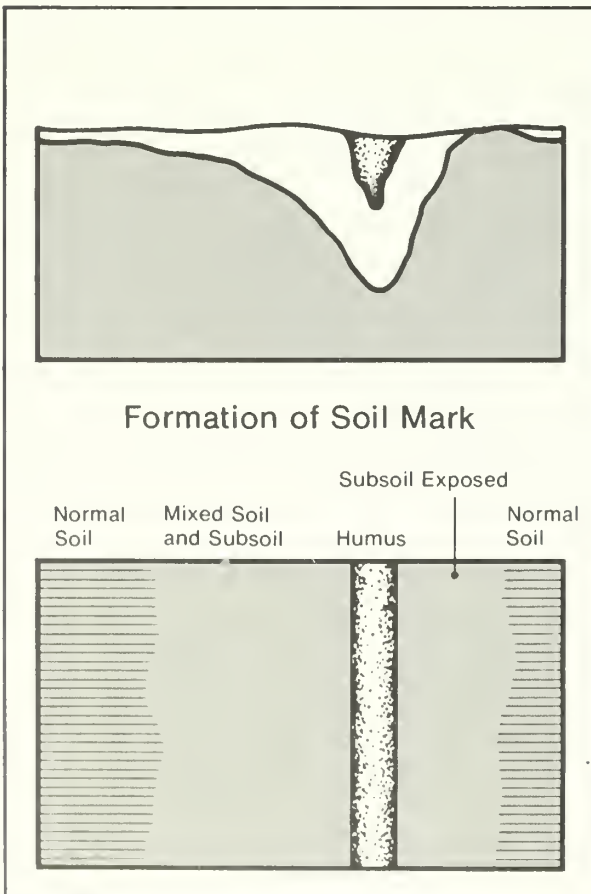

8-7 A terrain profile (above) showing how shadow marks result from a low sun angle with a vertical view of similar terrain in the lower view.

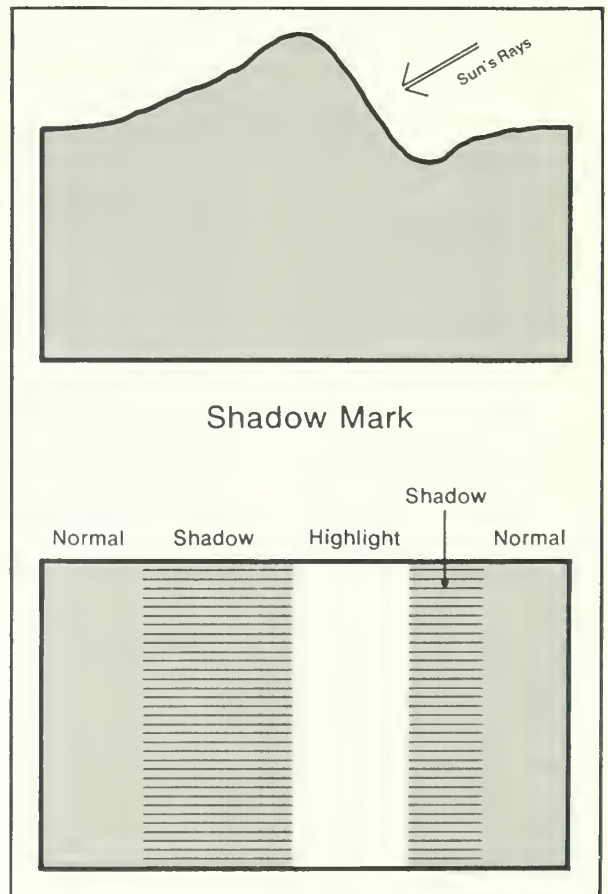

Plant growth differences due to root-penetration variations may result from the remains of features such as filled-in ditches or buried foundations. If the buried feature lies below the normal plowing depth, the crop marks may reappear each growing season. A stimulation of plant growth over filled-in ditches results in *positive* crop marks; where growth is inhibited, the surface indication is a *negative* crop mark (fig. 8-5).

Positive plant marks are often well-developed for subsoils composed of compacted gravels, chalk, or silt; limestone and loose gravels are apt to be much poorer for producing positive marks. The kind of subsoil has a lesser effect on negative marks, because buried impervious materials nearly always inhibit the growth of plants directly overhead.

Grains such as wheat are the best kinds of crops for producing distinctive marks, although native grasses are also good indicators. Vertical photography is preferred for registering crop marks that result from differences in plant density. Oblique views with a low sun angle may be more desirable for detecting subtle marks that are based on plant height or color differences, however. Photographic flights over cultivated areas are ideally planned for dry weather as the crops are nearing maturity.

## Site Detection from Soil Marks

When features such as ditches, depressions, or excavations are filled in, the result is an anomalous soil profile. In some cases, soils are mixed in such a way that the original subsoil appears at the surface. The variations in soil color, texture, or moisture can often be seen on aerial imagery as soil marks, even when such delineations are indistinguishable by terrestrial observation (fig. 8-6).

Soil marks may indicate the presence of buried archeological sites, although it will be recognized that similar markings can also result from more recent activities such as buried pipelines, underground utility cables, abandoned roads, or contemporary drainage ditches. The most striking soil marks are produced where there is a significant color contrast between the "normal" surface soil and the disturbed fill material. The marks usually show up best when the

soils are drying out—two or three days after a heavy rain.

Where there is little difference in soil coloration, marks or delineations may still be found on the basis of differential moisture retention. For detecting these kinds of soil-moisture differences, it is usually desirable to utilize an infrared film emulsion.

Soil marks are most easily seen when they occur in cultivated areas, and they may be especially vivid right after the plowing of fallow fields. The marks may remain visible for hundreds of years, provided the buried feature or disturbed soil is below plowing depth. Of course, as surface soils become more uniform due to cultivation, the soil marks will gradually become less distinct and they may even disappear altogether.

Soil marks are key diagnostic features in the aerial detection of covered archeological sites. The intelligent interpretation of unusual soil delineations has led to the discovery of many burial mounds, walled cities, fortifications, and ancient irrigation systems.

## Site Detection from Shadow Patterns

When the sun's rays fall obliquely on irregular terrain features, even minor surface configurations may be outlined by a distinct pattern of shadows. Such shadows can be useful site indicators of features that may pass unnoticed on the ground, e.g., eroded burial mounds, worn-down earthworks, old hedgerows, and wall fragments. These subtle relief differences are indicated by the contrasting tones of shadows, normal image shades, and highlighted zones (fig. 8-7).

Minor terrain irregularities require a very low sun angle for the production of useful shadow patterns. Therefore, early-morning or late-afternoon flights may be essential for obtaining the desired image characteristics. The sun's direction, as well as its elevation, can be important in revealing diagnostic shadows. For example, linear patterns are most clearly seen when the sun's rays strike the terrain feature at right angles; the same feature may be invisible if it happens to trend in a parallel direction. For exploratory flights, it is therefore desirable to obtain imagery during different times of the day.

Interpretation problems may be caused by shadows of obscuring objects, such as hills, trees, or buildings. The masking of indistinct shadow patterns by vegetation can be partially overcome by photographing forest regions when deciduous plants are leafless.

## Other Methods in Archeological Remote Sensing Interpretation

Remote sensing interpretation furnishes information for framing or restructuring research problems as well as much of the specific data necessary to resolve the posed questions. In order to take advantage of this capability, the archeologist should become proficient in determining the significance of the information derived through interpretative procedures. Illustrations of such determinations are too numerous for a complete listing. Some of the more general examples will be discussed here and others will be considered in the supplements to this volume.

**Site Prediction.** Site predictions have been made with considerable success in a number of regions utilizing remote sensing procedures in conjunction with a knowledge of the form, preferences, and habits of the cultures being studied. In addition, a considerable knowledge of the geomorphology or land form of the area is required.

In the Estancia Basin of central New Mexico, there was in the early Holocene, Pleistocene, and earlier geologic epochs, a large lake which, during a period of drying up and receding, etched beach terraces around its periphery. The cultural sequence of the area is well known and the locations of sites in the sequence were predictable. The Anasazi or prehistoric Pueblo Indians occupied the region after the lake had disappeared. Consequently, the areas above the ancient shore lines, the beach terraces and the lake bottom could safely be forecasted to contain archeological evidence of their former presence. The western archaic culture predated the Anasazi, and its artifactual remains too were found throughout the area. The paleo-Indian hunters were some of the earliest inhabitants of the region and disappeared before the lake had completely withdrawn. Consequently, the lithic re-

mains of their way of life are not sought on the lake floor but rather above the beach terraces and favorable hunting spots along the old shore line (fig. 8-8).

Some other land forms which are often more easily identified and studied on aerial photos than from a ground vantage point and which can be used in site prediction procedures are fossil stream channels, or bows, playas, bolsos, lynchets, lava flows, dune fields, moraines and other glacial features.

**Relative Age Dating.** *Relative dating* of archeological sites, that is, their correct temporal relationships can sometimes be accomplished with data derived from remote sensing interpretations. For instance, in Chaco Canyon, a masonry village was built directly on the trace of an old stream channel (Plate 5). In front of the structure, a younger channel scar is visible. Beyond it is the present day deeply entrenched arroyo.

Another example is in ancient Lake Estancia where the water had receded completely by approximately B.C. 4000. Consequently, western Archaic sites found on the lake bottom date from that point in time onward. Western Archaic sites found on or above the beach terraces and mapped on aerial photography, are of comparable age or older.

There are many other means of determining relative age of cultural features which are specific for different cultural and physiographic settings and some of which are set out in the supplements to this volume.

**Demographic Analysis.** Much prehistoric demographic information is derived from remote sensor data. A census of the Anasazi inhabitations of Chaco Canyon, New Mexico has been calculated by using an equation for determining populations based upon the area of domestic architecture of modern Indian pueblos and the quantified spatial data in photogrammetric maps of the ancient house blocks in the canyon. With this derived formula and a room count and measurements of the ancient Anasazi dwellings, estimates were computed which correspond closely with estimates based on different criteria.

**Functional Analysis.** A vast network of prehistoric roads was engineered by the Chacoan peoples in the Four Corners region of the Southwest



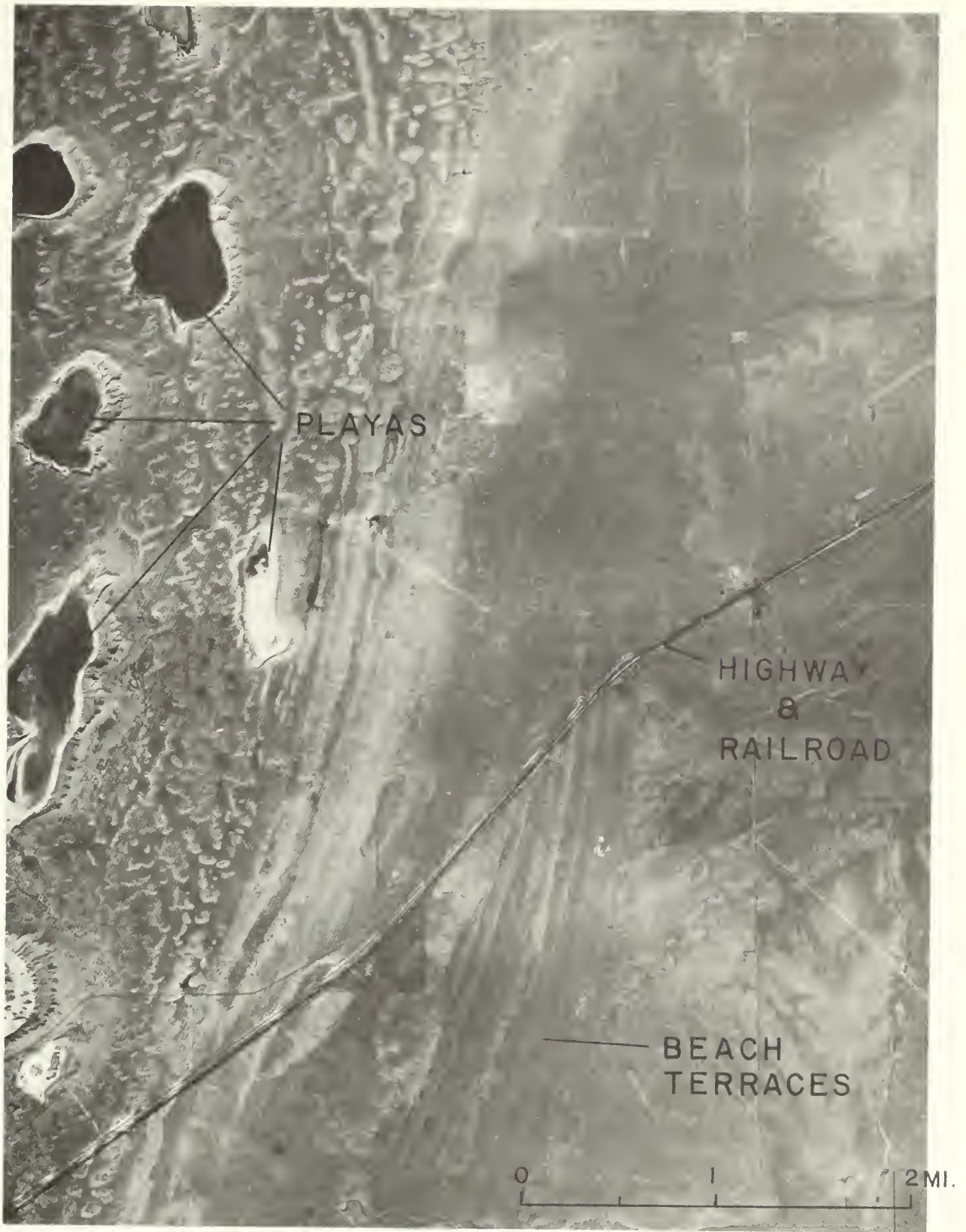

8-8 A vertical aerial photograph of the beach terraces of ancient Lake Estancia in central New Mexico.

approximately one thousand years ago (Plate 6). The only feasible method of mapping this network was by using aerial photography taken in different years and seasons and of various scales. The result was the realization that the segments, still visible as straight lineal scars on the surface, were part of a roadway system that connected far flung communities and resource areas.

In order to arrive at some concept of the function of the roadway system, a technique frequently applied to modern transport systems by geographers was called upon, that is, graph theory analysis. As a result of this work, the Chacoan system appears to be "unconnected", that is to say there were relatively few connections between major sites and between important terminals and activity areas as identified on the photographs. This characteristic together with the extreme straightness of the Chacoan roadways bring archeologists closer to an understanding of the nature of the traffic on these ancient highways. Unconnected, straight-line systems are today characteristic of railroads and superhighways and the function of the prehistoric system was probably comparable to that of the modern ones. Systems of this type are designed when their builders are disposed to expend a large amount of energy and resources in planning, engineering, and construction in order that eventual transport over the system would be direct, efficient and economical. Such planning and construction was reasonable only when large quantities of economically or ideologically important traffic flowed over the roads. This could be great numbers of people, goods or both.

**Volumetric Analysis.** Calculations of the volume of earth, stone and cultural debris have been made of sites prior to excavation using photogrammetric map data. These data are useful for arriving at precise estimates of the quantity of materials to be handled or removed during excavation. Comparative studies of site sizes and volumes are another possibility. Controlled sampling of a measured trash dump can be quantitatively analyzed and sound projections of artifact content developed.

**Excavation Recording.** The recording of features during the course of a dig is done in numerous established ways. However, phased photogram-

metric mapping records and saves a wealth of statistical information (see Section 9). Such maps are made from controlled vertical photographs taken at intervals. They preserve pictorially and graphically much of the evidence that is normally destroyed during the removal of earth, artifacts, structures and debris. These photos and resultant maps become historical documents which will furnish valuable information to subsequent investigators.

**Ecological Stratification.** At least two procedures can be followed in developing maps which portray ecological zonation. With sufficiently large scale aerial photos, plant types or plant communities can be mapped in considerable detail directly from the photographs in conjunction with concurrent field checking. Density analyzing equipment also can be applied to differentiating gross aspects of natural phenomena (Plate 7).

For topographic information, standard U.S. Geological Survey topographic quadrangles—currently constructed with stereoplotters and aerial photography—are available for much of the country. If not available in desired scales, however, the procedure for planimetry and form lining as described in Section 5 may also be applied.

## Remote Sensing in Cultural Resource Management

With the increase in pressures in the United States for more and more efficient management of our cultural resources, there is a need as well for new and productive methods of aiding administrators in planning and operations. Remote sensing techniques can help the manager in a number of ways. It is apparent that the exploration and discovery methods described elsewhere can provide information on resource inventories. In addition, photogrammetric base maps provide much environmental and statistical input for the manager and for such activities as those of ruin stabilization crews under his direction.

Perhaps one of the most useful aspects of remote sensing in cultural resource management is the capability of monitoring the impact of natural forces and visitation on areas set aside for

use by the public. Early aerial photography taken by the Soil Conservation Service and the U.S. Geological Survey provide what are in effect historic documents which depict environmental situations at a given time in the recent past. Current aerial photography then can be acquired and used for comparative purposes and for determining impact. In addition, repetitive space imagery is available and for some purposes is useful in monitoring large cultural resource areas. When imagery is acquired according to the need and specifications of particular cultural resource areas, it can be employed by managers in numerous ways: archeological surveys, floral studies and mapping, topographic and planimetric mapping, architectural studies, and exhibits.

Finally, the proper planning, use and application of remote sensing techniques in cultural resource areas will result in economic benefits since these procedures are often more economical to apply than many of the standard on-the-ground methods.

## Summary

Figure 8-9 was designed to furnish a review of the interpretative process. When the archeologist has defined a significant problem, it is assumed that he has or will acquire knowledge of field conditions to support his inferences. The next or concurrent step is a literature search on available information relevant to the problem and to appropriate remote sensing procedures. Following these steps, the archeologist determines the specification for the acquisition of the remote sensing data that will best lend themselves to the resolution of his problem. Two sources of data are available to him: 1) the extant photography and tapes from governmental and commercial organizations, and 2) data acquired on the basis of his specifications formulated with reference to his specific problem.

When the data are assembled, they are examined and selected for quality, contrast and other characteristics most applicable to the investigator's needs and the process of analysis begins. Into this analysis will feed biological, geological, geomorphological, pedological, geographical and other information. When this is completed, an interpretation is made and an in-

ferential analysis derived from the assembled information.

At this stage, a field check may or may not be necessary to determine the validity of conclusion derivations and inferences made during the data analysis. After any required field check or test and after necessary adjustments in the interpretation, there are two routes for the archeologist to follow in the presentation of the significance of his analysis which are not mutually exclusive. One is the evaluation or resolution of the problem as initially defined, and the other is the application of findings to cultural resource management, archeological or administrative. When these tasks have been completed, a report is prepared for presentation to a sponsoring agency or interested colleagues.

Figure 8-10 is a matrix of sensor systems mentioned above showing some of their uses in archeological remote sensing research. The chart is intended as a general guide to the selection of sensors for various combinations of direct and related ancillary culture resource investigations. It is apparent that conventional photography, particularly black-and-white photography, has the broadest range of application. However, the tabulation should not be construed as minimizing the value and utility of other systems which may indeed provide the critical information and capability in some interpretative endeavors.

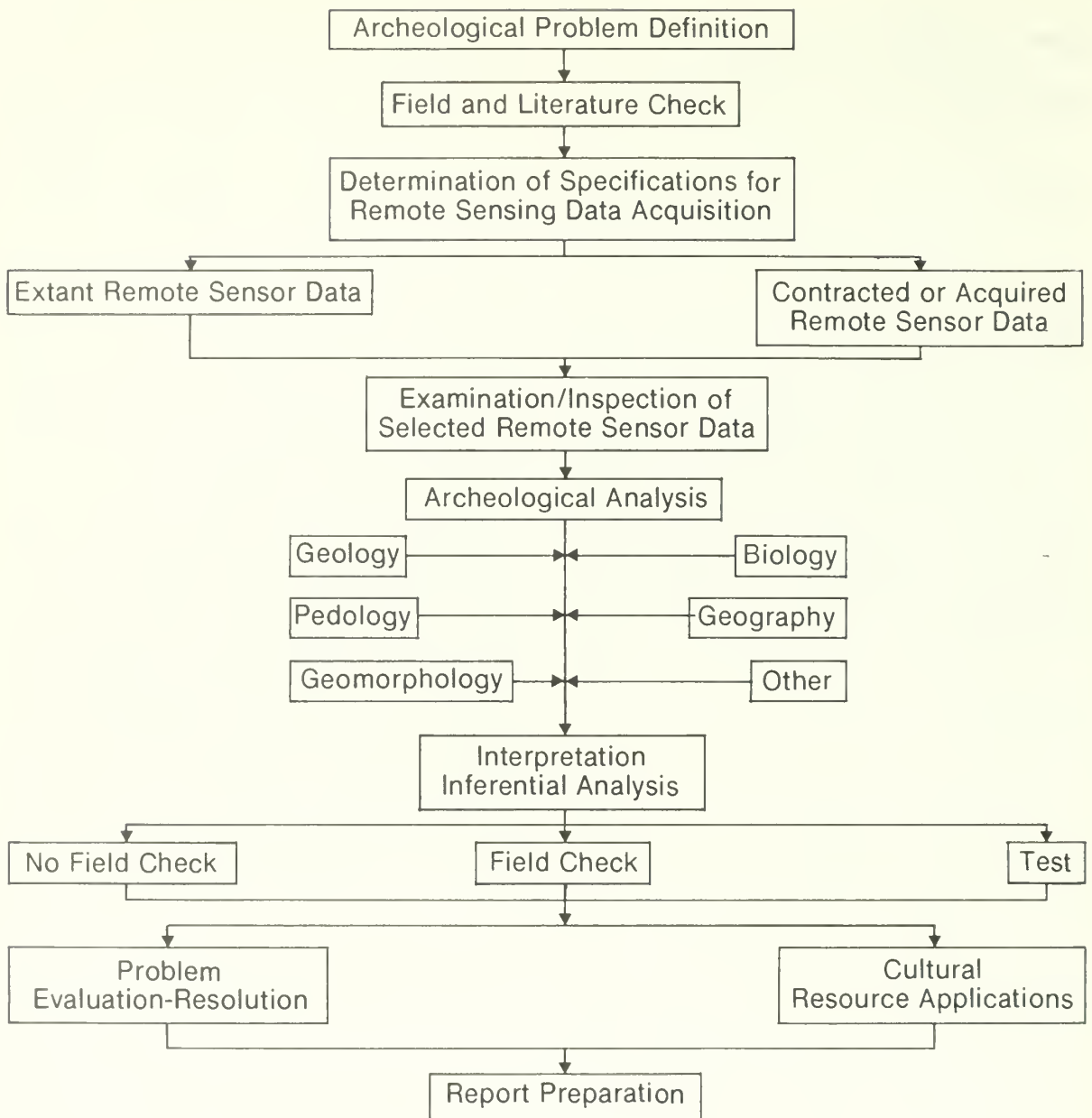

8-9 A suggested procedure in archeological remote sensing.

	Detection / Location	Site Component Analysis	Cultural Resource Analysis	Demographic Resource Monitoring	Demography	Settlement Patterns	Geomorphology	Topography	Paleogeomorphology	Vegetation Phytology	Vegetation Patterns	Rock Outcrop	Natural Resources Communities	Sedimentation	Erosion	Soil Types	Soil Temperature	Ground Water Discharge
--	----------------------	-------------------------	----------------------------	---------------------------------	------------	---------------------	---------------	------------	--------------------	----------------------	---------------------	--------------	-------------------------------	---------------	---------	------------	------------------	------------------------

**PHOTOGRAPHIC SENSOR SYSTEMS**

Black and White Photography	●	●	●	●	●	●	●	●	●	●	●	●	●	●	●	●	●	●
Black and White Infrared Photography									●	●		●	●					●
Color Photography	●	●	●	●	●	●	●	●	●	●	●	●	●	●	●	●	●	●
Color Infrared Photography	●		●					●	●		●							●
Multiband Photography	●	●	●	●	●	●	●	●	●	●	●	●	●	●	●	●	●	●

**NON-PHOTOGRAPHIC SENSOR SYSTEMS**

**Imaging Sensor Systems**

Thermal Infrared Scanner	●																●	●
Radar					●	●	●			●	●							
Multispectral Scanner	●		●		●	●	●	●		●	●						●	●
Television	●		●									●						

**Non-Imaging Sensor Systems**

Radar	●	●																
Electrical Resistivity	●	●																
Magnetometer	●	●																

8-10 Some Remote Sensor systems used in archeological and related investigations.

# Photogrammetric Methods in Archeology

## Introduction

Much of a prehistorian's field time is occupied not in physically digging and troweling but in sketching the details which unfold before him. Experiments in photogrammetric documentation of prehistoric structures indicate that, especially in the case of large archeological sites, photogrammetric techniques frequently save greater quantities of data, furnish higher levels of accuracy of stored information and accelerate the recording process.

The goals of many archeologists are: 1) to record and explain specific evidence found in the archeological record, and 2) to understand the basic adaptive processes operative in cultures in the past which served to cast the mold of the archeological record. There are other implicit and ancillary goals which the prehistorian cannot overlook. The archeological record constitutes one of the most complete, complex and potentially useful records at our disposal concerning human behavior. Consequently, preserving this record is as important an objective as safeguarding a great library. Accurate maps are valuable historical records which can be drawn upon in future research and serve as an archive should a site be totally excavated, accidentally destroyed or surreptitiously altered.

Cost estimates and reconstruction strategies are facilitated by the use of accurate maps and digitized coordinate data. The archeologist's investigations are also aided by pre-excavation maps which serve as a guide for sampling strategies and work/time estimates.

## Definition

Photogrammetry has been defined in a number of ways, each definition containing one or more of the following elements: technique, science, art, photography, imagery, data, information, mapping. The roots of the word itself are photograph and meter. Thus, a general definition of photogrammetry is expressed as the science, or techniques, of deriving quantitative measurements from photographs. The photographs may be either those taken from an air or space platform or from a terrestrial or ground station. This is a traditional definition which is still valid but which today must be amplified to include the manipulations of quantitative data from remote sensors other than photographic cameras. For instance, reduction of taped data from spacecraft provides maps of many varieties useful in environmental and land use studies (Plate 8). Thus an expanded definition reads: the techniques and science of deriving quantifiable information in graphic form from remote sensing instruments. This explanation of photogrammetry purposely excludes *interpretation* since interpretation is a separate function which encompasses, in addition to scientific procedures, a distinct element of art.

9-1 A terrestrial photogrammetric drawing of Mummy Cave Ruin, Canyon del Muerto, Arizona. Note architectural details and contours in the vertical plane.

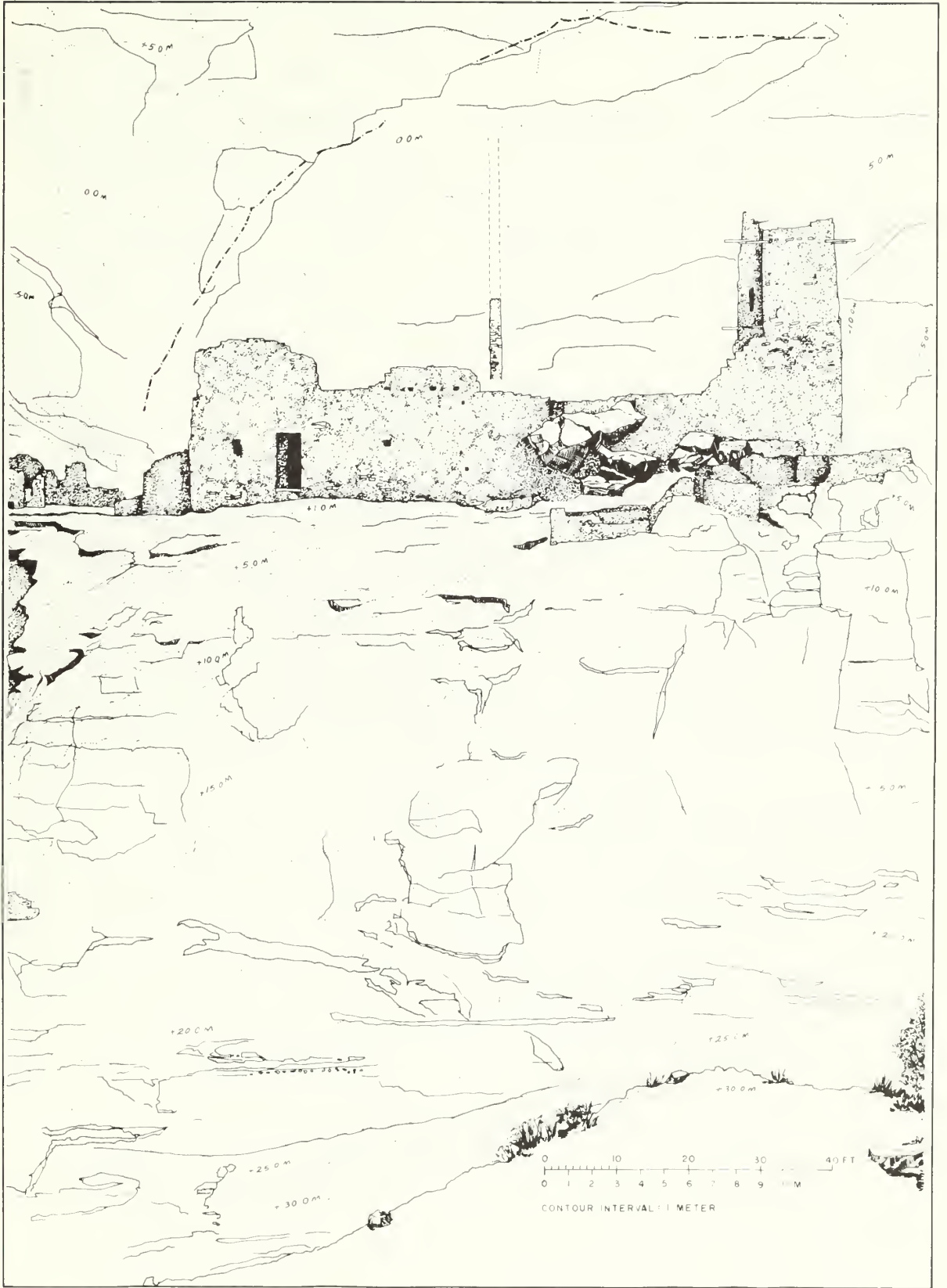

### Cartographic Photogrammetry

Cartographic or mapping photogrammetry has been used for detailed intrasite recordings of archeological digs and, under certain ideal circumstances of site visibility, for inventory maps containing a sizeable sample of the cultural resources. In addition, topographic and planimetric maps now commonly compiled with the aid of controlled aerial photography and a stereoplotter are invaluable to the field archeologist (fig. 8-1 and 8-2).

Photogrammetric techniques have been used extensively in mapping urban, suburban and rural population areas, and these methods can be applied to some problems of historical archeology where considerable physical remains are still evident, i.e., ghost towns, homesteads, trails, roads, etc. Environmental maps of various types have been plotted—geological, geomorphological, soils, vegetative, hydrologic, oceanographic, and bathymetric.

There are numerous other types of conventional and not-so-conventional maps which have been drawn photogrammetrically, e.g., military and planetary (planets and their satellites).

### Non-Cartographic Photogrammetry

Photogrammetric techniques are applied in ways other than mapping. In architecture, for instance, the elevations of buildings, wall profiles and wall features have been drawn (fig. 9-1). The facades and design elements of structures have been recorded in detail. In addition, deformation of building beams, rooflines, walls and the like have been detected by precision photogrammetric drawing.

The measurement of material volume is an important use and application of non-cartographic photogrammetry. The amounts of rock and gravel removed from quarries or gravel pits, road cut mass, and other earth quantities are readily and accurately calculated. This technique is of particular utility in estimating volumes of materials in tells, pyramids, trash dumps and similar mounded sites (fig. 8-1).

To adequately plan a photogrammetric program, the definition of archeological objectives is a prime consideration. The type of end products—maps, map scales, volumes, profiles, etc.—must be determined in order to coordinate the acquisition of imagery with the capabilities of the particular plotter to be used.

For visual stereoscopic interpretation, imagery of good pictorial quality is required. However, for measurement purposes, imagery of metric quality as well as of pictorial quality is needed. To obtain such photography, metric or calibrated cameras designed for use with plotting instruments must be used over the target area. Fine grained, high resolution aerographic film is an additional requirement (see Section 1). The film format used must also be compatible with the plotter. Generally, black-and-white, panchromatic, 9-inch roll film is flown; and stereo models are reproduced on diapositives or positive transparent glass plates for use in the plotter projectors.

In planning an archeological mapping project, there are a number of variables that must be coordinated. The principal consideration is the type and scale of the required graphics. For instance, if the planimetry and topography of a large pueblo ruin at a map scale of 1 in. = 40 ft. and with a contour interval of 1 ft. is desired, the scale of the acquired aerial photography must be compatible with the capabilities of the plotting instrument used in the map compilation. In this case, a photo ratio scale of 1:2400 (1 in. = 200 ft. or 1cm. = 24 m.) is required for use in a plotter with a five time enlargement ratio. The aerial photography for the project obtained by an experienced pilot and cameraman will have flight line overlap of 60 percent and sidelap of about 30 percent (see Section 2).

Stereoplotting instruments available today vary widely in their capabilities and limitations. Consequently, it is necessary to be familiar with the characteristics of the equipment to be used. There are several important factors to consider:

- a. The format or diapositive size accepted by the plotter.
- b. The enlargement ratio of the plotter from the scale of the diapositive to the map scale which may vary from 1 to 6 times.



- c. The principal distance of the plotter which is the distance from the plane of the diapositive to the projector lens and which normally corresponds to the focal length of the camera.
- d. The vertical performance latitude of the plotter which is based upon the projection distance. This, in turn, corresponds to camera height which should be flown at an elevation five times or more greater than the maximum topographic difference.
- e. The C factor of the plotting instrument which is the ratio of the height of the camera above ground level to the contour interval that can be drawn within specified limits of error.

When these variables are controlled, the area or extent of ground coverage should be determined for each stereogram or for each neat stereo-model, that is, that area completely covered by a stereopair of one flight line and partially by the sidelap in adjacent flight lines (fig. 9-2). This is particularly important to the archeologist since his area of interest frequently can be contained in a single stereomodel with proper planning and thereby reduce costs of image acquisition and plotting. From charts, such as Table 9-1, ground areas can be calculated readily for the needed coverage.

Horizontal and vertical ground control must be established for stereo-models used in plotters. This can be accomplished in two ways: 1) control set with the aid of highly visible panels (fig. 9-3) prior to overflight and surveyed for intervening distances and differences in elevation, and 2) control points identified on photos and surveyed after overflight. The setting of horizontal distances between panels is a function of the desired photo scale and can be determined by reference to Table 9-1. The number of vertical control points which should appear on each stereomodel is at least three and the number of horizontal points is three. When large areas are to be mapped, *bridging* may be employed in order to extend the control and thereby reduce the field survey work. Bridging consists of projecting a controlled model across intervening models with minimal or no control points to another controlled model in the flight line, thereby effecting a tie (fig. 9-4).

There is a great body of literature on the types, capabilities, operations and optical and mechanical characteristics of stereoplotters. The reader is referred to the accompanying bibliography for further details.

The foregoing discussion was based upon the use of vertical aerial photography. With slight variations the same principles apply to oblique aerial photography and to terrestrial photography taken for architectural or other purposes.

**Table 9-1** Method of determining necessary aerial photo scale and horizontal ground control for desired map scale.

Photo Scale	Maximum Horizontal Distance in Stereo Model	Negative Ratio Scale	Resultant Map Scale
1" = 500'	1800' × 3200'	1 : 6000	1" = 100'
1" = 250'	900' × 1600'	1 : 3000	1" = 50'
1" = 200'	720' × 1275'	1 : 2400	1" = 40'
1" = 150'	540' × 950'	1 : 1800	1" = 30'
1" = 100'	360' × 630'	1 : 1200	1" = 20'

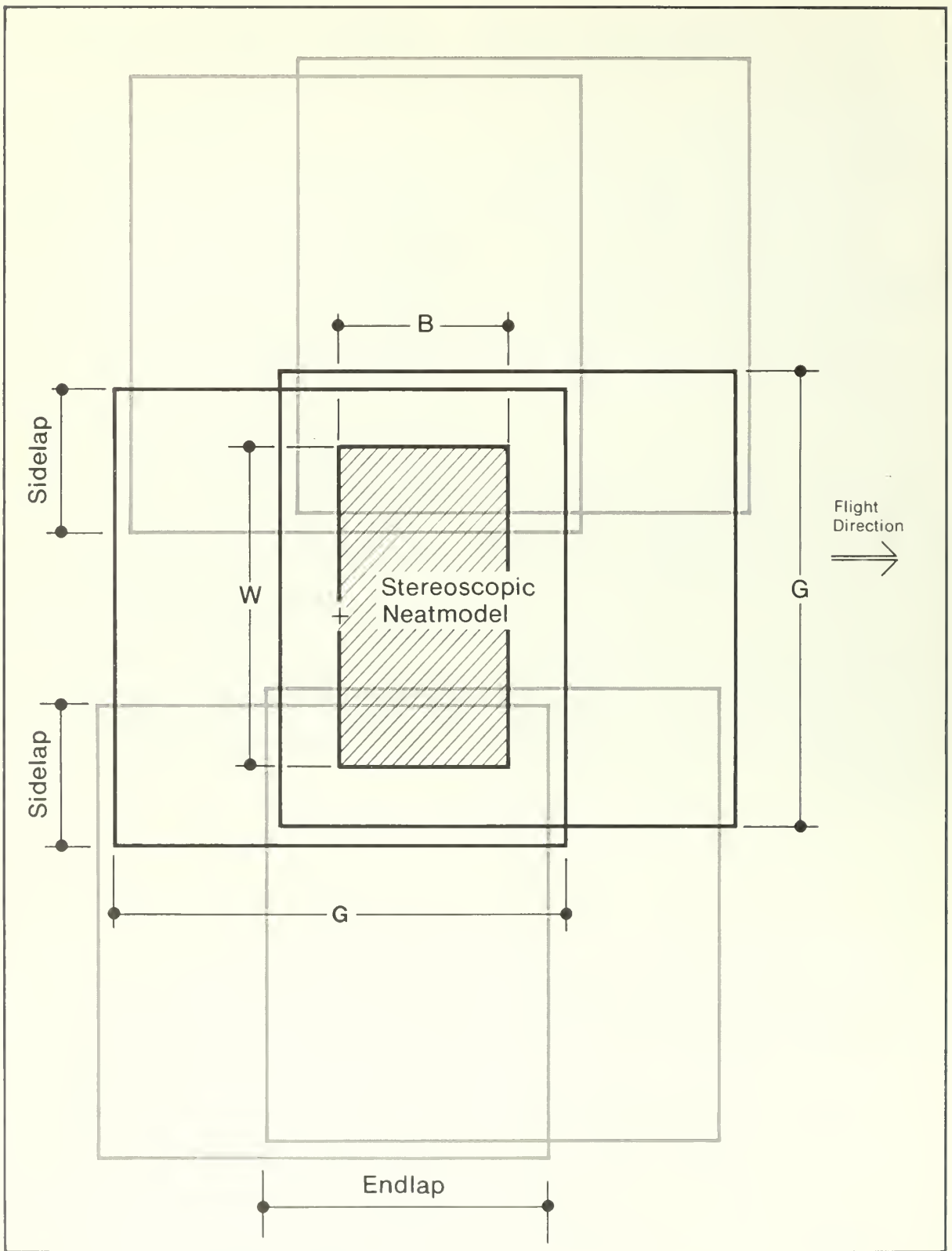

9-2 An example of a "neat" stereo model.



**Plate 1** An example of a color infrared photograph of a portion of Chaco Canyon National Monument, New Mexico. Different types of living vegetation can be distinguished in this oblique shot by their variable shades of red. Note light areas within the vegetation cover where mustard weed growing on culturally disturbed soil has rapidly matured and no longer appears as viable growth.

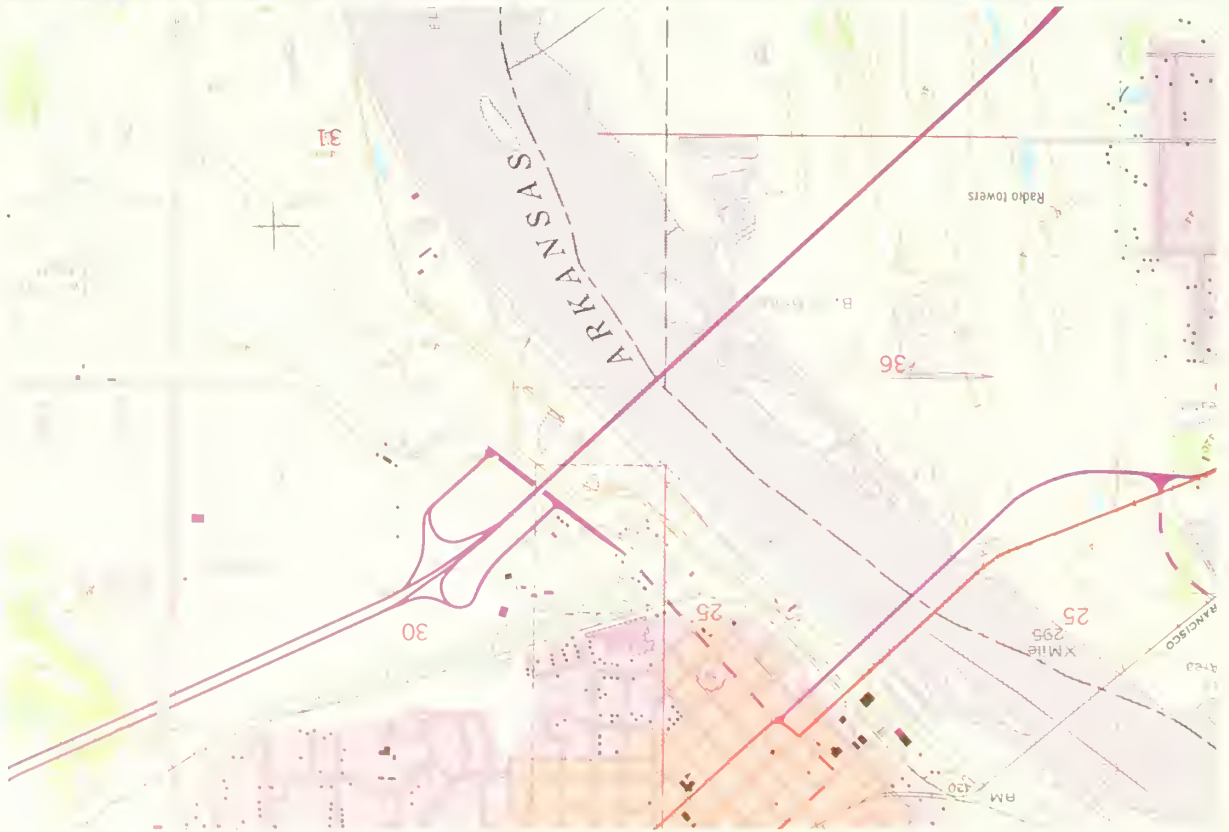

**Plate 2** Portion of topographic map (above) and aerial photograph of Fort Smith, Arkansas. *Courtesy U.S. Geological Survey and U.S. Department of Agriculture.*

**Plate 3** Portion of a USGS topographic map (right) based on the polyconic projection. Note that the map margin is referenced by geographic coordinates, by UTM grid marks, and by township-range designations. Scale is about 1:24000; contour interval is 20 feet.



Mapped, edited, and published by the Geological Survey

Control by USGS and USC&GS

Topography by photogrammetric methods from aerial photographs taken 1965. Field checked 1966

Polyconic projection 1927 North American datum  
 10,000-foot grid based on New Mexico coordinate system, west zone  
 1000-meter Universal Transverse Mercator grid ticks, zone 13, shown in blue

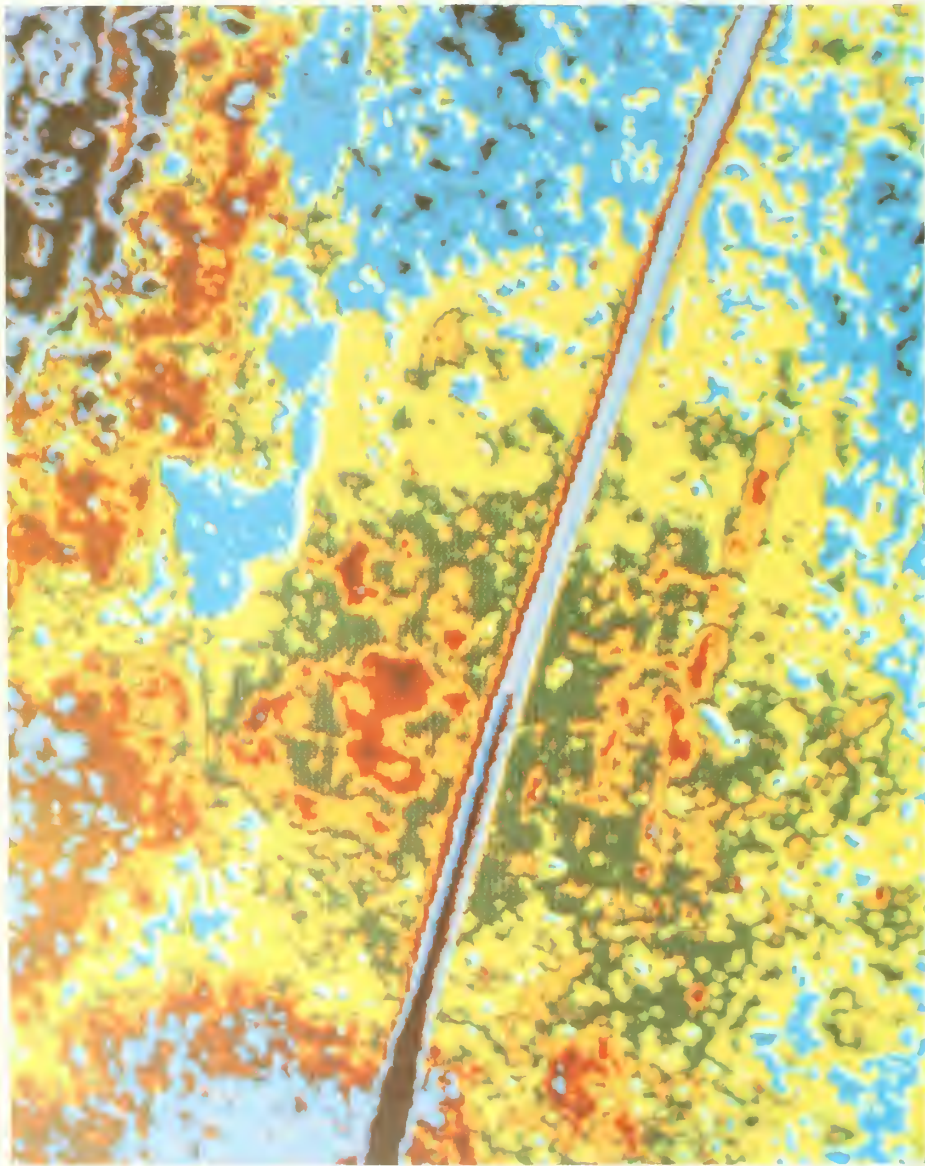

**Plate 4** A prehistoric agricultural field (left) portrayed on density analyzer. A modern road crosses the field.

**Plate 5** An aerial view (below) of the Pueblo ruin Wijiji in Chaco Canyon National Monument. The vegetation pattern indicates that the masonry structure was built on an old stream channel.



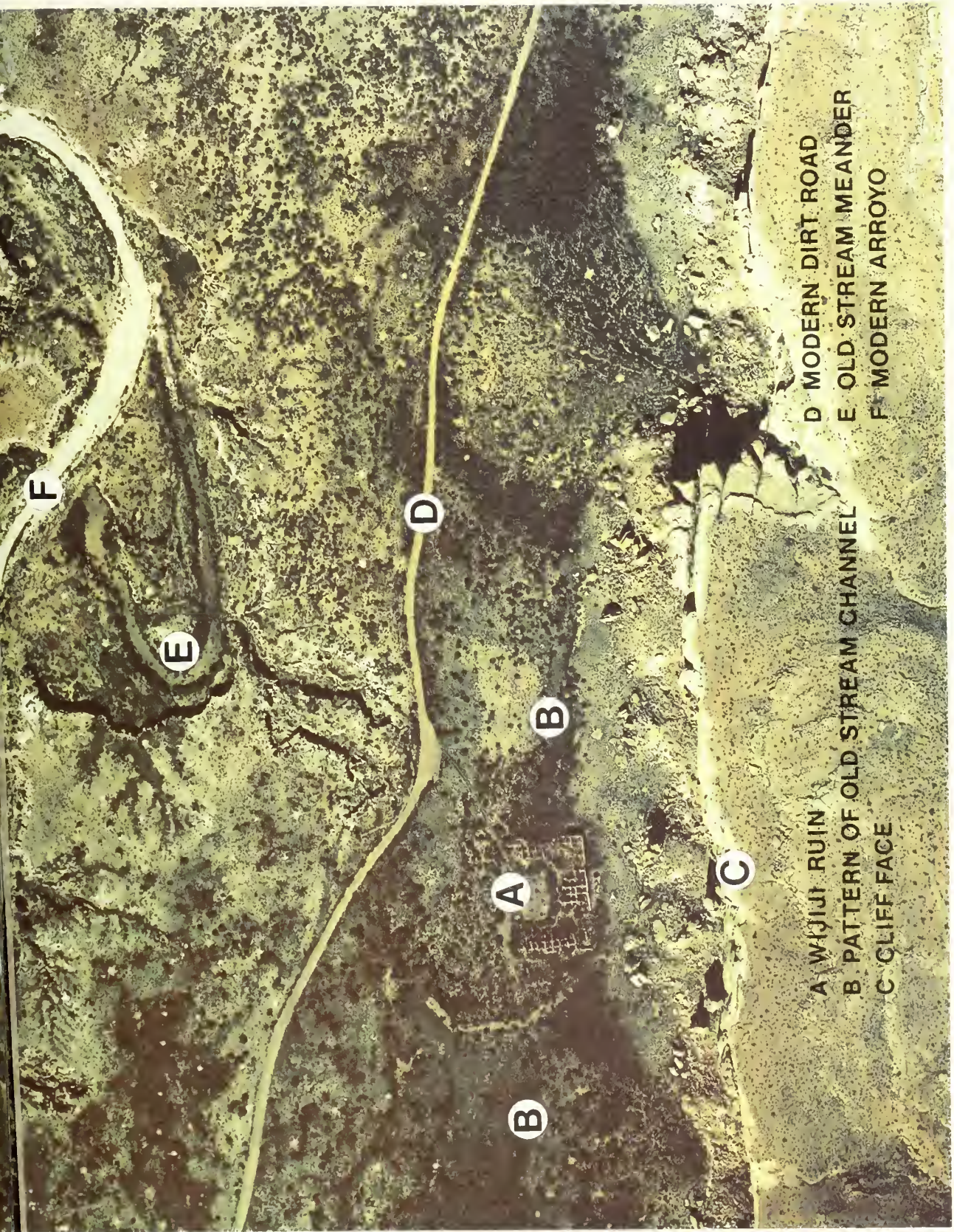

D MODERN DIRT ROAD  
E OLD STREAM MEANDER  
F MODERN ARROYO

A WIJITI RUIN  
B PATTERN OF OLD STREAM CHANNEL  
C CLIFF FACE





**Plate 6** A portion of a USGS topographic map of San Juan County, New Mexico, showing the location of some prehistoric roadways.

**Plate 7** Ecological variations (left) in the Chaco Canyon National Monument area of Northwest New Mexico are distinguished by the various color bands displayed on the TV monitor of a density analyzer.

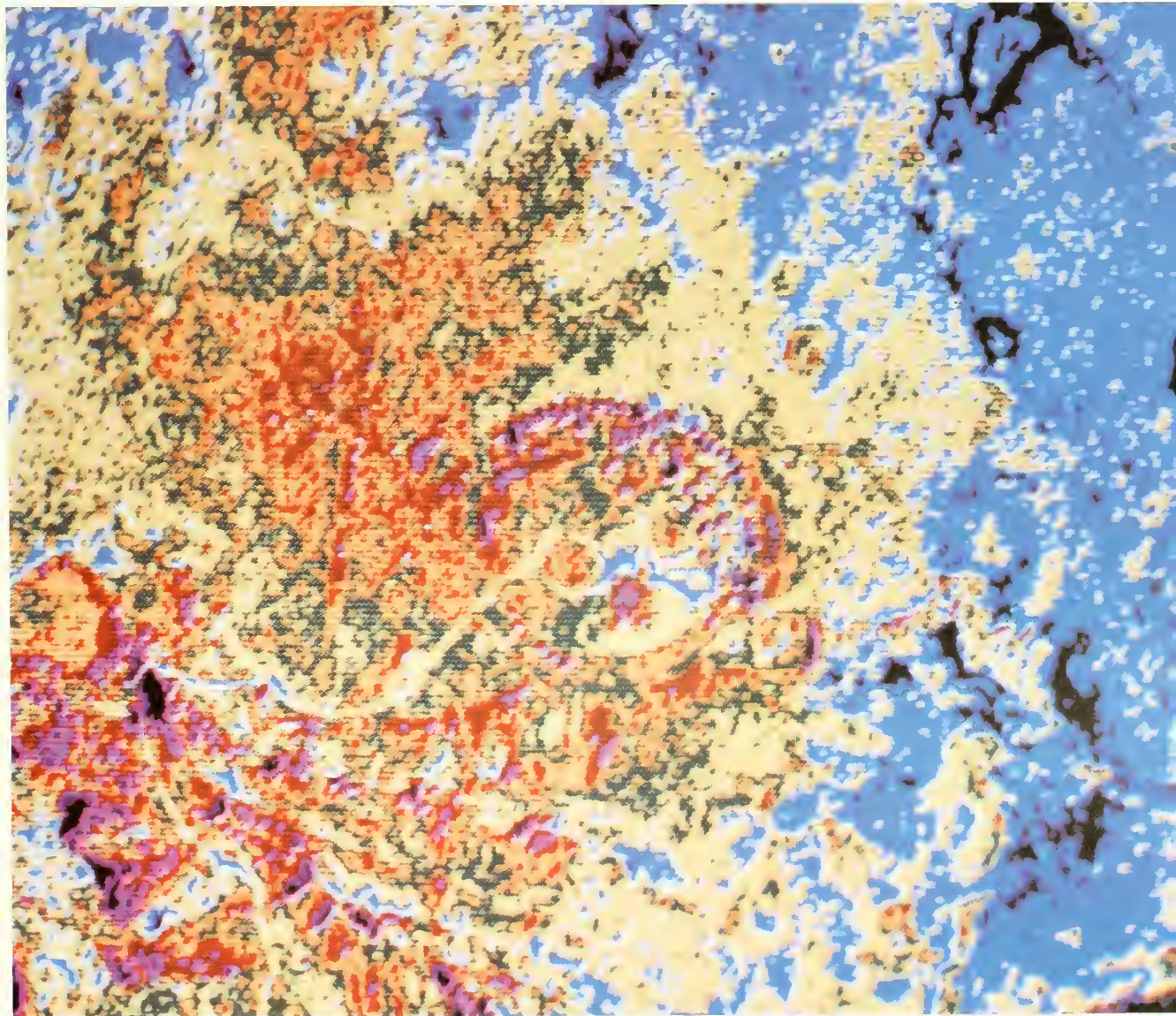

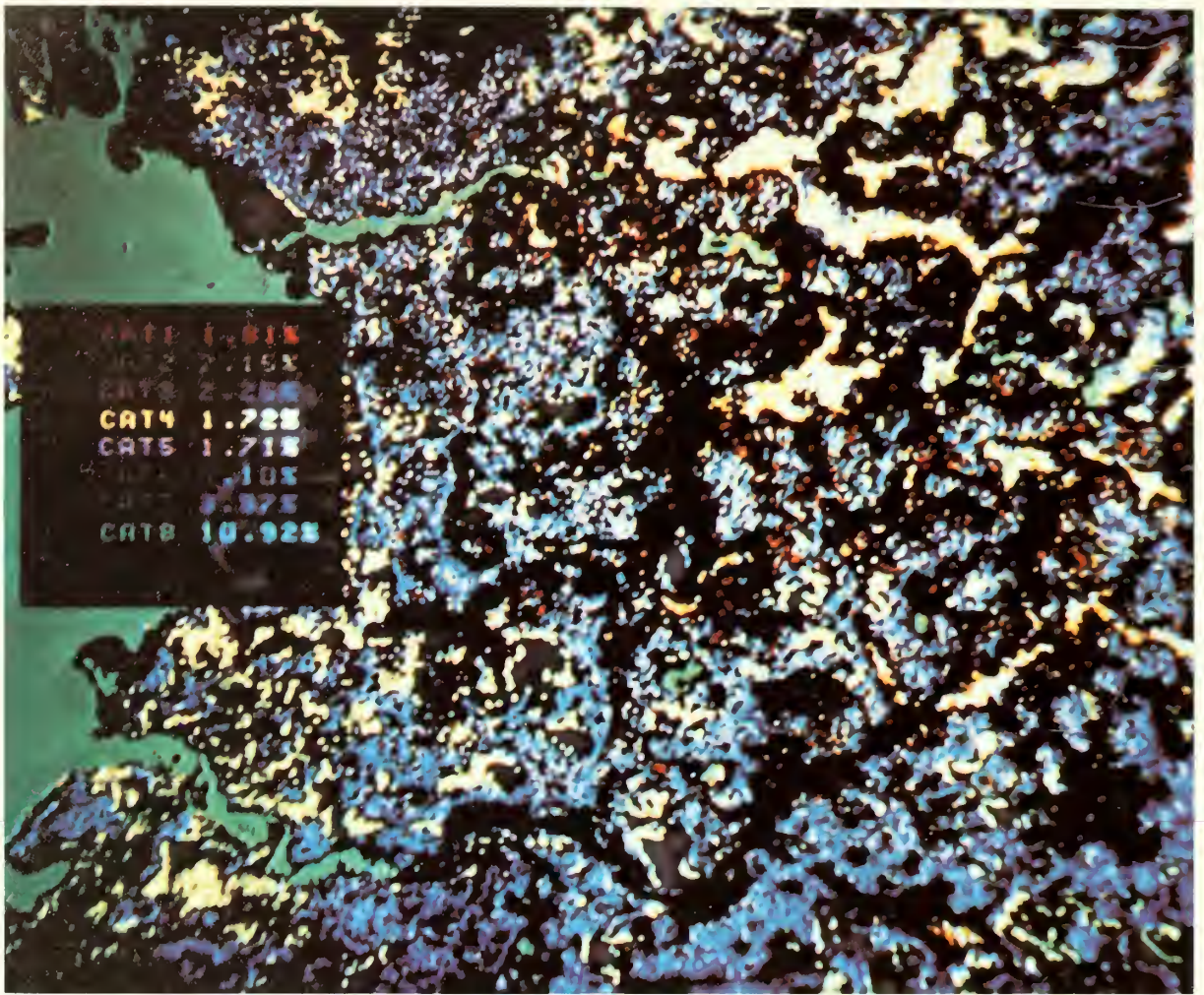
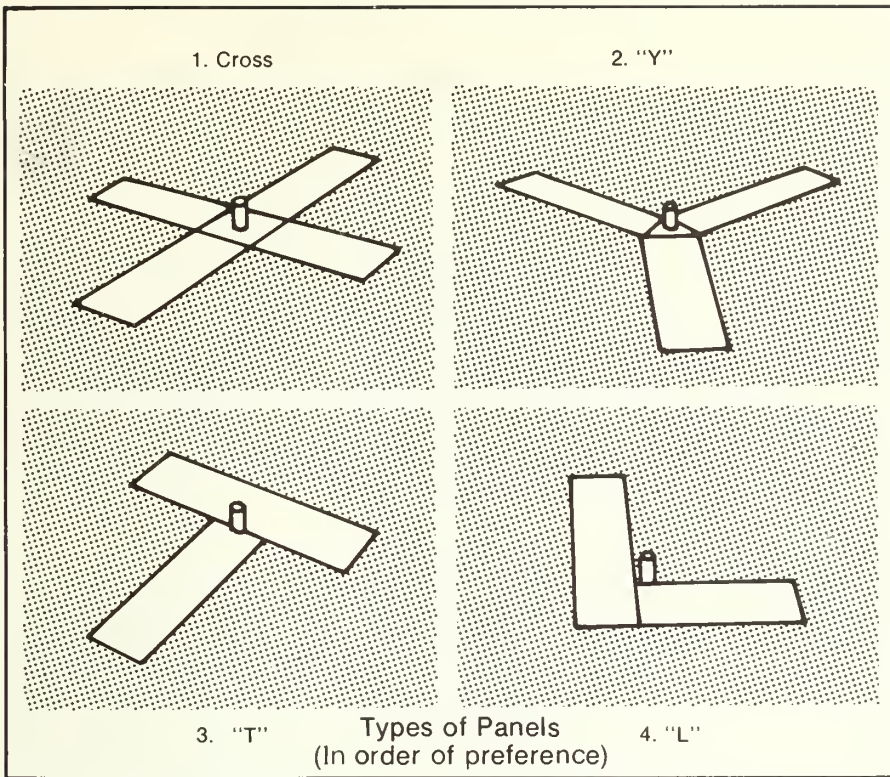
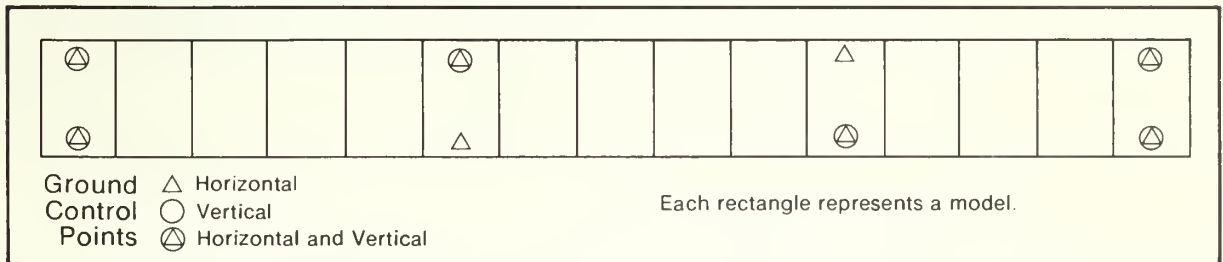

Plate 8 A vegetation thematic map of an area near Tampa Bay, Florida. Eight distinct biomes were identified and mapped from an ERTS image: 1) citrus groves and low field crops; 2) freshwater marsh; 3) meso-phytic hardwoods; 4) pine/oak uplands; 5) pine; 6) pine/oak scrub; 7) wet prairie; and 8) water. Note the relative area of each theme as listed in the inset. *Courtesy Dames & Moore.*



9-3 Types of plastic panel layouts used to pre-mark horizontal and vertical ground control points.



9-4 An aerial photographic flight line prepared for control extension or bridging and illustrating the location of horizontal and vertical ground control points.

## Archeological Applications of Photogrammetry

### Planning

As a rule of thumb, photogrammetric techniques are economically feasible for mapping sites that contain relatively complex features and are two or more acres in size. Planimetric and microtopographic site maps can be employed in planning excavation strategies, in spoil dirt re-

moval and disposal, in reconstruction analyses, and in ruin stabilization. From the data illustrated in figure 8-1, the volume of a large site and its trash dump was calculated using the photogrammetric contour data and available computer program for mass determination. These data then served for designing excavation sampling procedures and as a base for statistical extrapolations and comparisons.

Planimetric and microtopographic maps have numerous other uses in pre-excavation planning depending upon the specific nature or complexity of the sites to be dug.

## **Intra-site Maps**

An extension of the photogrammetric procedures used prior to excavation is phased photography and mapping. At opportune times during the excavation of a site, vertically controlled photography from aircraft, bipod, tripod or other stable platforms can be taken. In addition to affording the archeologist an exact record of conditions and progress at a specific time, it preserves a wealth of measurable data which is normally removed or destroyed in the process of digging. In order to extract analytic data from this photography, the same ground control previously established for the initial site map can be repanelled for each new photo mission. Concurrently, or at some future time, the imagery can be used to compile maps for different phases of the field work. This approach can help minimize interruptions caused by ground surveys of exposed site features.

## **Digitized Photogrammetric Data**

In the stereo compilation procedure, the development of data falls into three separate and distinct stages. Two of these have already been discussed, the plotting of cultural and natural planimetric features and of topography using small contour intervals. The third stage involves deriving digitized data on computer cards in the form of x, y and z coordinates of a site with the x and y coordinates defining horizontal position and the z coordinates defining elevations. The digitized coordinates can be established for wall remnants, wall intersections, floor features, artifact locations, terrain data, etc. These data are automatically punched on computer cards by the plotter operator or in accordance with the desired output (fig. 5-5). The storage of this information on computer cards affords the archeologist a wide range of computer functions to assist in analysis. The manipulation of these data can yield accurate profiles. With the aid of computer graphic programs, perspective drawings can be prepared from various vantage points (fig. 9-5). When the digitized photogrammetric data are coupled with quantitative field data, it is possible to again use graphic programs to reconstruct architectural sites, for instance, with greater verity than through the traditional use of the artist's conception.

## **Hard Access Documentation**

Many archeological sites are difficult to map because of their locations. Such sites often occur in caves or overhangs. Others are covered with lake or sea water or are found in areas of difficult ground access. Frequently, aerial or terrestrial photogrammetry provide the most adaptable and economical means for documentation. Photos for cave site mapping can be obtained either from ground stations or from aircraft with side looking cameras, and both architectural elevations and maps can be compiled from these data (fig. 9-1). In some instances, lake and sea waters are shallow and clear enough for site recording on photography.

## **Other Applications**

In previous discussions, various applications of photogrammetric technique have been noted such as the plotting of environmental maps and the monitoring of the impact of natural and human agents on cultural resources. Many other potential uses exist, some of which are specific to certain archeological or physiographic provinces and are discussed in the supplements to this volume.

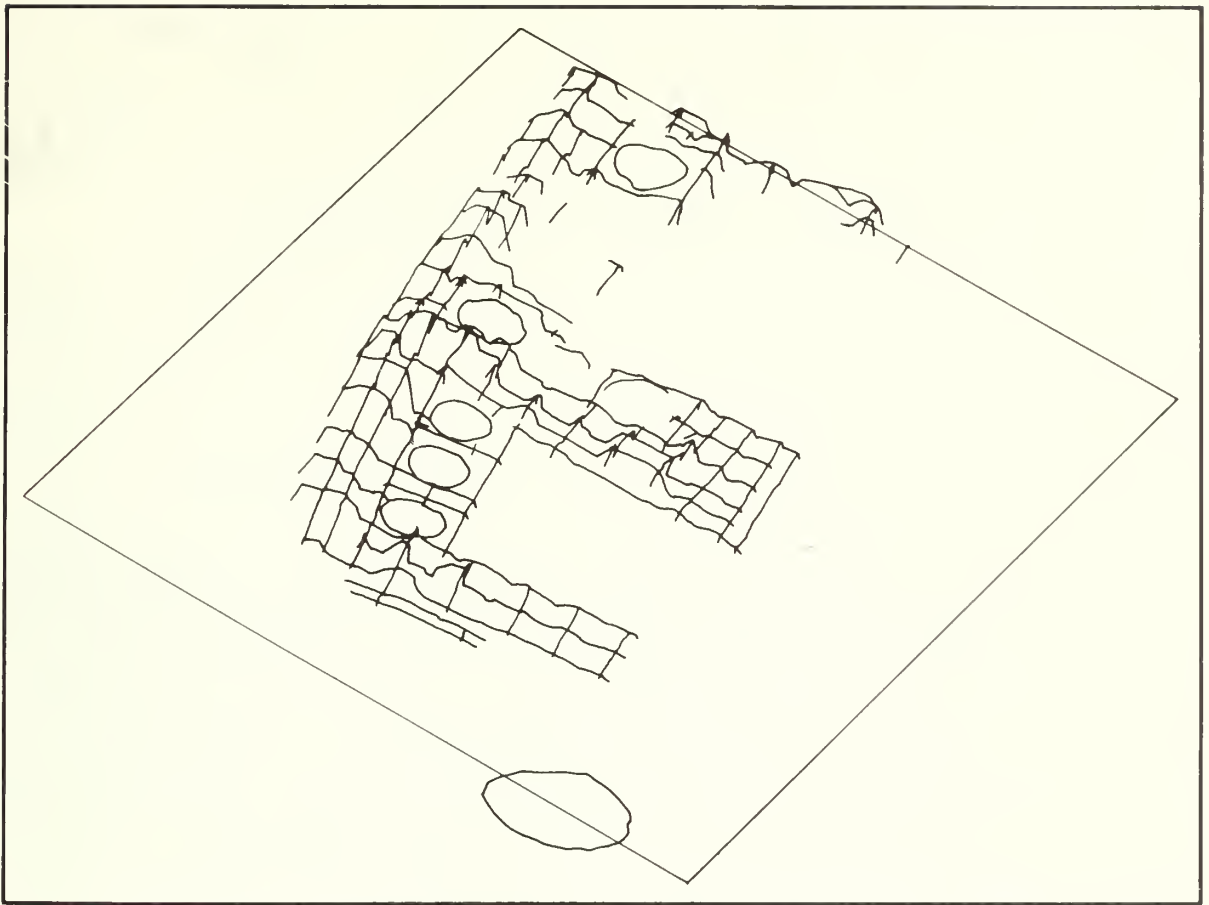

9-5 A computer plot of the Kin Bineola Ruin. Digitized horizontal and vertical photogrammetric data were used to produce this perspective drawing.

## Section 10

# Generalized Specifications for Archeological Photography

### Introduction

Existing photographic coverage may be unsuitable because of age, season, film-filter combination, or scale. As a result, there is considerable interest in the purchase of new photography taken specifically to meet the requirements of a given project. Although photo interpreters may rarely take their own photographs, they may have the responsibility of drawing up preliminary specifications or flight plans, estimating costs, and inspecting the finished product.

Both experienced personnel and modern equipment are essential for obtaining high-quality exposures that are necessary for precise photogrammetric work. Aerial photographs that fail to supply the quantity and quality of information desired cannot be considered inexpensive by any standard. It is therefore wise to negotiate only with reputable aerial survey firms that maintain high standards in their work.

Numerous trials of photographic and non-photographic sensors have been conducted to determine their suitability for archeological exploration. Since the major objective of each investigator tends to differ, however, a listing of rigid specifications cannot be set forth. On the other hand, there are general recommendations that can be made regarding imagery of ancient sites; those described here refer to conventional optical imagery.

As a general rule, vertical photographs are preferred for reconnaissance flights and for the detailed photogrammetric mapping of known sites. Oblique photographs are occasionally specified for detecting crop or plant marks, and they may also provide important records during site excavation or restoration.

### Season of Photography

The optimum season for scheduling photographic flights depends on the nature of features to be identified or mapped, the film to be used, and the number of days suitable for aerial photography within a given period of time. Unfortunately, extended periods of clear, sunny weather may not occur during the season when photography is desired. As evidence of this fact, Table 10-1 was compiled from weather records to illustrate the average number of "photographic days" per month in each state.

For the detection and evaluation of most archeological sites, drier seasons of the year are preferred over wetter periods, because the loss or retention of moisture by various soils provides more striking tonal contrasts during dry seasons. Density and condition of covering vegetation is an additional seasonal factor for consideration. It is obvious that growing-season photography is required for the detection and evaluation of crop or plant marks, for example.

Reconnaissance flights over humid regions are likely to be more successful when masking deciduous plants are leafless. And soil marks are most readily discernible after plowing but prior to the establishment of an agricultural crop. In summary, the photographic season must be selected on the basis of specific project objectives; there is no single period of the year that is "best" for all forms of archeological exploration.

### Time of Day

This specification is largely governed by the

**Table 10-1** Average number of days suitable for aerial photography, by state and month of year<sup>1</sup>

NAME OF STATE <sup>2</sup>	Jan.	Feb.	Mar.	Apr.	May	June	July	Aug.	Sept.	Oct.	Nov.	Dec.	Total per year
<i>Number of days</i>													
Alabama	6.4	6.4	6.9	6.5	6.2	4.1	2.4	2.9	5.9	11.4	9.7	6.3	75.1
Arizona	15.3	13.2	15.7	18.3	22.0	23.7	15.8	15.8	20.2	21.5	18.3	16.2	216.0
Arkansas	7.0	6.9	6.6	6.5	5.6	5.8	5.7	7.2	9.1	11.8	9.0	7.8	89.0
California	7.4	6.7	8.4	9.3	9.7	11.5	12.7	12.8	13.3	13.1	10.8	8.6	124.3
Colorado	7.5	5.8	5.7	4.6	4.6	7.0	5.5	5.4	10.3	11.3	9.4	8.4	85.5
Connecticut	6.1	7.1	7.6	6.4	6.8	5.2	5.4	6.4	6.7	9.1	6.1	6.6	79.5
Delaware	5.5	5.7	5.6	5.2	5.5	4.0	4.5	4.7	6.6	9.2	6.4	5.5	68.4
Florida	5.9	6.7	7.4	6.7	5.0	2.7	1.4	1.5	2.8	6.0	7.7	6.3	60.1
Georgia	6.8	7.1	7.9	7.3	6.6	4.1	2.4	3.0	5.6	10.8	10.6	7.3	79.5
Idaho	2.7	3.7	4.3	4.6	5.5	8.8	13.3	18.4	12.5	9.8	5.7	3.5	92.8
Illinois	4.9	4.7	4.8	5.1	5.1	4.5	6.3	6.5	7.9	9.0	6.4	5.1	70.3
Indiana	4.2	3.8	4.2	4.5	4.4	3.7	4.9	5.4	7.1	9.2	6.2	4.4	62.0
Iowa	5.8	5.4	4.8	5.3	5.0	4.8	7.2	6.6	7.8	8.9	5.9	5.4	72.9
Kansas	8.5	7.3	6.7	5.8	5.6	6.2	8.7	8.2	9.6	10.7	9.6	8.4	95.3
Kentucky	4.8	4.8	5.2	5.4	6.1	5.8	7.2	6.3	8.4	10.7	7.2	4.9	76.8
Louisiana	6.9	6.3	6.6	6.9	6.2	5.7	3.9	4.7	7.3	11.3	9.6	6.8	82.2
Maine	5.6	6.3	5.8	4.8	3.8	3.4	3.4	4.6	5.8	6.8	4.0	5.3	59.6
Maryland	5.2	5.5	5.4	5.0	5.0	3.8	4.1	4.3	6.3	8.9	6.0	5.4	64.9
Massachusetts	3.6	4.2	4.5	4.0	3.5	2.5	2.2	3.6	4.2	5.1	3.5	3.4	44.3
Michigan	2.2	3.1	4.1	5.0	4.8	4.6	5.4	4.6	4.6	4.3	1.9	1.9	46.5
Minnesota	5.4	5.8	5.2	5.8	5.6	4.9	7.1	6.8	6.2	6.3	4.2	5.1	68.4
Mississippi	6.3	5.8	6.8	6.3	5.7	5.5	3.2	3.8	6.6	11.8	9.4	6.2	77.4
Missouri	7.4	7.1	6.8	6.8	6.8	6.8	9.2	8.9	9.9	11.6	9.2	7.3	97.8
Montana	3.5	3.7	3.5	4.1	3.8	4.2	9.9	9.0	7.3	6.9	4.3	4.0	64.2
Nebraska	6.9	5.7	5.3	4.9	4.7	5.5	8.4	7.4	8.9	10.2	7.1	6.9	81.9
Nevada	6.7	6.2	7.5	8.4	8.7	13.8	18.6	18.8	16.9	14.2	10.1	7.4	137.3
New Hampshire	3.3	3.8	4.1	3.7	3.2	2.2	2.0	3.0	3.8	4.4	2.8	2.9	39.2
New Jersey	6.1	6.2	6.1	5.6	6.5	4.5	5.3	5.6	7.1	9.9	7.3	5.9	76.1
New Mexico	10.5	8.4	8.7	8.3	8.1	10.5	5.4	5.3	10.2	14.0	12.7	12.3	114.4
New York	2.3	2.9	4.1	4.9	5.5	4.8	4.8	4.7	5.5	5.1	2.5	2.0	49.1
North Carolina	6.8	6.8	7.3	7.1	6.7	4.2	3.6	3.9	6.1	11.1	10.1	7.4	81.1
North Dakota	5.0	4.9	4.4	5.3	5.1	4.3	7.5	7.2	6.7	6.6	4.3	5.3	66.6
Ohio	3.5	3.1	4.1	4.8	5.8	5.1	6.2	6.2	7.3	7.1	4.3	2.9	60.4
Oklahoma	8.0	6.7	6.5	5.8	5.4	6.7	7.6	8.7	9.5	10.8	10.3	8.3	94.3
Oregon	2.0	2.6	3.0	4.7	5.0	6.8	13.4	13.2	9.5	6.2	2.9	2.1	71.4
Pennsylvania	3.0	3.2	3.9	4.2	4.9	3.7	3.9	4.2	5.8	6.4	3.4	2.5	49.1
Rhode Island	4.9	5.3	6.6	5.8	5.9	4.0	5.1	6.1	6.6	7.8	5.3	4.4	67.8
South Carolina	6.4	7.0	7.1	7.0	6.0	3.3	2.3	2.9	5.0	10.1	10.3	7.2	74.6
South Dakota	5.9	5.4	4.9	4.8	4.5	5.0	8.2	8.3	8.6	8.9	6.4	6.7	77.6
Tennessee	5.3	5.5	6.2	5.4	5.7	4.5	4.2	5.1	7.1	11.2	8.8	5.9	74.9
Texas	7.8	6.3	7.2	7.1	6.4	7.4	5.7	6.7	7.6	11.1	8.9	7.9	89.1
Utah	7.1	5.8	7.0	7.1	7.8	12.6	11.0	11.3	14.2	13.7	10.4	7.6	115.6
Vermont	2.9	2.9	3.3	3.1	2.7	1.7	1.6	2.0	3.2	3.2	1.5	1.8	29.9
Virginia	5.4	5.6	5.6	6.1	5.9	4.1	4.3	4.4	6.0	9.2	7.1	5.6	69.3
Washington	1.3	2.1	2.6	3.7	3.8	5.1	11.6	11.1	7.5	4.9	1.6	1.2	56.5
West Virginia	2.3	2.2	3.6	3.8	4.2	3.0	3.2	3.0	4.0	4.7	3.2	2.0	39.2
Wisconsin	4.9	5.3	4.6	5.1	5.4	4.6	7.0	6.5	6.4	7.2	4.4	4.7	66.1
Wyoming	4.7	4.5	4.3	3.8	3.2	4.8	6.9	6.7	8.2	7.9	5.7	5.5	66.2

<sup>1</sup>Compiled from U.S. Weather Bureau Records. Figures shown represent the number of days per month with 10 percent cloud cover or less. Averages should be used with discretion, as wide variations may occur from one part of a state to another.<sup>2</sup>Data unavailable for Alaska and Hawaii.

desired sun angle on the date of photography. For any given latitude and day of the year, the sun's declination can be determined in advance from a solar ephemeris or from special charts available through aerial film manufacturers.

The detection of shadow marks, as noted previously, may require a very low sun angle. In such instances, early morning or late afternoon photography may be required, especially at the lower latitudes. For most vertical reconnaissance photography, however, a high sun angle is desired to minimize shadows and to obtain maximum illumination of terrain features. Adequate sunlight is especially important for producing correctly balanced color photographs.

When scheduling midday photographic flights at the lower latitudes, precautions should be taken (especially with wide-angle camera lenses) to avoid "hot spots" on the exposures. Such hot spots, or sunspots, result from the absence of shadows (light halation), and they may destroy the exposure detail on a portion of each photographic frame. Since hot spots occur near a prolongation of a line from the sun through the exposure station (camera lens), their probable occurrence can be predicted—and avoided—by careful planning and timing of flights.

## Photographic Scale

Here we must distinguish between reconnaissance flights covering large regions as opposed to detailed photography of known or excavated sites. In the first instance, scales of 1:10,000 to 1:20,000 have been successfully employed in several regions. This could be due to the fact that existing black-and-white photography in this scale range is available at nominal cost in many parts of the United States. On the basis of research reports, scales in the range of 1:3,000 to 1:10,000 appear to be actually preferred. The potential of very small-scale imagery that is transmitted from earth-orbiting satellites has not been fully evaluated from the archeological viewpoint, but certain linear features such as ancient irrigation canals and extinct stream channels and gross environmental variations have been discerned on such imagery.

For photographing known, exposed, or excavated sites, photographic scales of 1:500 to

1:5,000 have been utilized by various investigators. Here, the scale specified is governed by the physical extent of the site and the degree of detail required. Extremely large scales are usually limited to sites being excavated or photogrammetrically mapped, e.g., structures such as burial mounds, fortifications, small villages, or pueblos.

## Type of Film

Early archeological investigations utilized black-and-white panchromatic photography—probably because this was the least expensive and most common type of coverage available. Panchromatic exposures made with a minus-blue filter are still considered quite useful, and may be regarded as fairly "standard" for preliminary reconnaissance flights.

A number of investigators have reported tests that were conducted to compare color or color infrared exposures with black-and-white photography, but such comparisons have proven inconclusive due to differences in timing, scale, weather, or other non-controlled experimental factors. There does seem to be general agreement that color exposures are superior to black-and-white photographs, even when the gain is limited to a saving of interpretation time. And color infrared photography may be favored for mapping subsurface details, such as shallow buried foundations and walls. It may also be surmised that color or color infrared exposures are superior for detecting soil marks and certain classes of crop or plant marks.

It is somewhat surprising that only a few experiments utilizing black-and-white infrared emulsions have been reported. Since this film is useful in finding buried pipelines (soil marks), it should be more fully evaluated for other applications. There is obviously a need for the continued investigation of multispectral imagery and for comparing film positives versus paper prints for detailed interpretation.

## Cost Factors

Other things being equal, the two factors normally having the greatest influence on photo-



graphic costs are scale and size of area involved. Prices per square mile increase as scales become larger and as the area covered becomes smaller. When the scale is doubled (as from 1:15,480 to 1:7,920), four times as many prints are required, with a proportionate increase in cost. For coverage at 1:15,840 (4 inches per mile), a good camera crew can photograph 750 to 900 square miles in 5 to 8 hours of flying time. Hence, photo coverage of small tracts will be influenced more by the cost of moving the plane and crew than by the actual flying time that may be involved.

## Inspection of Contract Photography

Infrequent purchasers of aerial photography may have difficulty in evaluating the finished product, because acceptance or rejection of photographic flights often requires checks of such items as tilting, overlap, scale, and print quality. As a means of translating technical specifications into guides for the neophyte inspector, an itemized imagery inspection checklist may prove useful (fig. 10-1).

Because of the time required, photo-scale checks are seldom made for individual prints. Instead, 10 or more overlapping prints are selected from each flight line for a check of the average scale across an expanded geographic transect. After the prints have been taped down in mosaic fashion, the distance between two points is carefully measured. By computing a simple ratio between the photo measurement and the corresponding distance on the flight map, average print scale can be quickly read from Table 10-2. Allowing for variations in local relief, this average should be within  $\pm 5$  per cent of the specified scale.

## IMAGERY INSPECTION CHECKLIST

Place of inspection \_\_\_\_\_ Inspector \_\_\_\_\_  
 Date \_\_\_\_\_ Area \_\_\_\_\_ Flight line \_\_\_\_\_  
 Roll \_\_\_\_\_ Exposures \_\_\_\_\_ through \_\_\_\_\_ Altitude \_\_\_\_\_  
 Date Flown \_\_\_\_\_ Time of day \_\_\_\_\_ to \_\_\_\_\_

**1. Film titles and symbols**

Prints not dated \_\_\_\_\_  
 Project, roll or exposure not shown \_\_\_\_\_  
 Scale and time not shown: first and last exposure \_\_\_\_\_

**2. Flight line orientation and overlap**

Line position or bearing incorrect \_\_\_\_\_  
 Forward overlap excessive \_\_\_\_\_ deficient \_\_\_\_\_  
 Deficient lap at break in line \_\_\_\_\_ At end of line \_\_\_\_\_  
 Sidelap excessive \_\_\_\_\_ deficient \_\_\_\_\_  
 Improper print alignment \_\_\_\_\_ Tilt \_\_\_\_\_

**3. Scale checks - flight map scale of \_\_\_\_\_ (see Table 5-2)**

Map Distance	Photo Distance	Ratio	Photo Scale
_____	_____	_____	_____
_____	_____	_____	_____
_____	_____	_____	_____

**4. Print Quality**

Print detail blurred \_\_\_\_\_  
 Chemical stains or blemishes \_\_\_\_\_  
 Excess contrast \_\_\_\_\_ Insufficient contrast \_\_\_\_\_  
 Clouds or shadows \_\_\_\_\_ Long image shadows \_\_\_\_\_  
 Hotspots \_\_\_\_\_ Excessive snow cover \_\_\_\_\_  
 Floodwaters \_\_\_\_\_ Smoke or fog \_\_\_\_\_

**5. Recommendations.**

- ( ) Acceptance of entire flightline \_\_\_\_\_
- ( ) Conditional acceptance \_\_\_\_\_
- ( ) Rejection - reflights necessary for exposures \_\_\_\_\_

**Table 10-2** Conversion ratios for determining the average scale of aerial photographs<sup>1</sup>

Flight map scales (R.F.)					Aerial Photo
1:250,000	1:125,000	1:62,500	1:31,250	1:15,625	Scale (R.F.)
<i>Scale conversion ratios</i>					
35.7	17.8	8.9	4.52	3.43	1:7,000
33.3	16.7	8.3	4.22	3.20	1:7,500
31.2	15.6	7.8	3.96	3.00	1:8,000
29.4	14.7	7.4	3.73	2.82	1:8,500
27.8	13.9	6.9	3.52	2.67	1:9,000
26.3	13.2	6.6	3.33	2.53	1:9,500
25.0	12.5	6.2	3.17	2.40	1:10,000
23.8	11.9	6.0	3.02	2.28	1:10,500
22.7	11.4	5.7	2.88	2.18	1:11,000
21.7	10.9	5.4	2.75	2.09	1:11,500
20.8	10.4	5.2	2.64	2.00	1:12,000
20.0	10.0	5.0	2.53	1.92	1:12,500
19.2	9.6	4.8	2.44	1.85	1:13,000
18.5	9.2	4.6	2.35	1.78	1:13,500
17.8	8.9	4.5	2.26	1.71	1:14,000
17.2	8.6	4.3	2.18	1.66	1:14,500
16.7	8.3	4.2	2.11	1.60	1:15,000
16.1	8.1	4.0	2.04	1.55	1:15,500
15.6	7.8	3.9	1.98	1.50	1:16,000
15.2	7.6	3.8	1.92	1.45	1:16,500
14.7	7.4	3.7	1.86	1.41	1:17,000
14.3	7.1	3.6	1.81	1.37	1:17,500
13.9	6.9	3.5	1.76	1.33	1:18,000
13.5	6.7	3.4	1.71	1.30	1:18,500
13.1	6.6	3.3	1.67	1.26	1:19,000
12.8	6.4	3.2	1.62	1.23	1:19,500
12.5	6.2	3.1	1.58	1.20	1:20,000
12.2	6.1	3.0	1.54	1.17	1:20,500

<sup>1</sup>To use the table, several contact prints should be lapped in mosaic fashion. Measure distance between two points easily recognized on photos and flight-map. With a photo distance of 18.8 inches and a map distance of 2.0 inches, ratio is 9.4. Assuming a flight-map scale of 1:125,000, this ratio is interpolated above as representing a photo scale of approximately 1:13,250.

## References:

# Photogrammetry, Photo Interpretation, and Archeological Applications

### AMERICAN SOCIETY OF PHOTOGRAMMETRY

1968. *Manual of color aerial photography*. American Society of Photogrammetry, Falls Church, Va.

1966. *Manual of Photogrammetry*. American Society of Photogrammetry, Falls Church, Va. Two vols.

### AVERY, T. E.

1974. *Techniques of aerial archeology*. Proceedings, International Soc. of Photogrammetry, Comm. VII, Banff, Alberta, Canada, 12 pp.

1970. *Photo-interpretation for land managers*. Eastman Kodak Co., Rochester, N.Y. Pub. M-76, 26 pp., illus.

1977. *Interpretation of aerial photographs*, 3rd ed. Burgess Pub. Co., Minneapolis, Minn. 392 pp., illus.

1966. *Forester's guide to aerial photo interpretation*. USDA Handbook 308, Government Printing Office, Washington, D.C. 40 pp., illus.

1960. *A checklist for airphoto inspections*. Photogrammetric Engineering 26: 81-84, illus.

### —, AND MERLE P. MEYER

1962. *Contracting for forest aerial photography in the United States*. U.S. Forest Service, Lake States For. Expt. Sta., Station Paper 96, 37 pp., illus.

### CARBONNELLE, MAURICE

1974. *Historic center conservation*. *Photogram. Engineering*, 40: 1059-1070, illus.

### DE LION, PORIFIRIO GARCÍA

1974. *Recuperación de datos y la fotografía aérea*. XI Congreso Internacional de Americanistas, Simposio de arqueología, 41 pp., illus.

### DEUEL, LEO

1969. *Flights into yesterday*. St. Martin's Press, New York. 332 pp., illus.

### EDDY, JOHN A.

1974. *Astronomical alignment of the Big Horn medicine wheel*. *Science* 184: 1035-1043, illus.

### GUMERMAN, GEORGE J. AND JAMES A. NEELY

1972. *An archeological survey of the Tehuacán Valley, Mexico: a test of color infrared photography*. *American Antiquity* 37: 520-527, illus.

### GUMERMAN, GEORGE J. AND THOMAS R. LYONS

1971. *Archeological methodology and remote sensing*. *Science* 172: 126-132, illus.

### LYONS, THOMAS R., B. G. POULS, AND R. K. HITCHCOCK

1972. *The Kin Bineola irrigation study: an experiment in the use of aerial remote sensing techniques in archeology*. Proceedings, Third annual conference on remote sensing in arid lands, Univ. of Arizona, Tucson, Az., pp., 266-283, illus.

### MAGNUSSON, MAGNUS

1972. *Introducing archeology*. The Bodley Head, Ltd., London. 127 pp., illus.

### MARTIN, ANNE-MARIE

1971. *Archeological sites—soils and climate*. *Photogram. Engineering*, 37: 353-357, illus.

### ST JOSEPH, J. K. S. (editor)

1966. *The uses of air photography*. John Baker Publishers Ltd., London. 166 pp., illus.

### SCHABER, GERALD G. AND GEORGE J. GUMERMAN

1966. *Infrared scanning images: an archeological application*. *Science* 164: 712-713, illus.

### STRANDBERG, CARL H.

1967. *Photoarchaeology*. *Photogram. Engineering*, 33: 1152-1157, illus.

### STUART, GEORGE E. AND GENE S. STUART

1969. *Discovering man's past in the Americas*. National Geographic Society, Washington, D.C. 212 pp., illus.

### VORBECK, EDUARD AND LOTHAR BECKER

1973. *Carnutum: Rom an der Donau*. Otto Müller Verlag, Salzburg, Austria. 114 pp., illus.

### WHITTLESEY, JULIAN H.

1970. *Tethered balloon for archeological photos*. *Photogram. Engineering*, 36: 181-186, illus.

### WILFELY, GORDON R.

1966. *An introduction to American archeology*, Vol. 1: North and Middle America. Prentice-Hall, Inc., Englewood Cliffs, N.J. 530 pp., illus.

# Historical Geography and Archeology

## Books

- BARADEZ, JEAN. *Fossatum Africae. Vue Aérienne de l'Organisation Romaine dans le Sud-Algérien*. Paris: Ars et Metiers Graphiques, 1949.
- BERESFORD, MAURICE WARWICK. *The Lost Villages of England*. London: Lutterworth Press, 1954.
- . AND ST. JOSEPH, J. K. S. *Medieval England, An Aerial Survey*. Cambridge: Cambridge University Press, 1958.
- BRADFORD, JOHN. *Ancient Landscapes: Studies in Field Archaeology*. London: G. Bell and Sons, Ltd., 1957.
- BROTHWELL, DON (ed.). *Science in Archaeology: A Comprehensive Survey of Progress and Research*. New York: Basic Books, Inc. Publishers, 1963.
- BRUCE-MITFORD, R. L. S. (ed.). *Recent Archaeological Excavations in Britain. Selected Excavations, 1939-1955, With a Chapter on Recent Air-Reconnaissance*. London: Kegan Paul, 1956.
- CRAWFORD, O. G. S. *Archaeology in the Field*. London: Phoenix House, Ltd., 1953.
- . AND KEILLER, ALEXANDER. *Wessex from the Air*. Oxford: Clarendon Press, 1928.
- CURWEN, E. CECIL. *Air Photography and Economic History: the Evolution of the Cornfield*. London: The Student's Bookshop, Ltd., London School of Economics, 1928.
- HARTSHORNE, RICHARD. *Perspective on the Nature of Geography*. Chicago: Rand McNally and Company, 1959.
- HOSKINS, WILLIAM GEORGE. *Leicestershire; An Illustrated Essay on the History of the Landscape*. London: Hodder and Stroughton, 1957.
- . *The Making of the English Landscape*. London: Hodder and Stroughton, 1955.
- KNOWLES, DAVID, AND ST. JOSEPH, J. K. S. *Monastic Sites From the Air*. Cambridge: Cambridge University Press, 1952.
- MITCHELL, J. B. *Historical Geography*. London: The English Universities Press, Ltd., 1965.
- MARGARY, IVAN DONALD. *Roman Roads in Britain*. London: Phoenix House, 1955.
- . *Roman Ways in the Weald*. London: Phoenix House, 1948.
- POIDEBORD, PETE A. *La Trace de Rome dans le Desert de Syrie, le Limes de Trajan a la Conquete Arabe, Recherches Aeriennes, 1925-1932*. Paris: Paul Geuthner, 1934.
- REICHE, MARIA. *Mystery of the Desert*. Lima: Editora Medien Peruana, 1949.
- SCHMIDT, E. F. *Flights Over Ancient Cities of Iran*. Chicago: University of Chicago Press, 1940.
- . *Flights Over Ancient Cities of Peru*. Chicago: University of Chicago Press, 1940.
- SMITH, H. T. U. *Aerial Photographs and Their Applications*. New York: Appleton, Century, Crofts, 1943.
- STRANDBERG, CARL H., AND TOMLINSON, ROY. *Photoarchaeological Analysis of Potomac River Fish Traps*. Alexandria, Virginia: Itek Data Analysis Center, 1965.
- THOMAS, WILLIAM L., JR. (ed.). *Man's Role in Changing the Face of the Earth*. Chicago: University of Chicago Press, 1956.

## Publications of the Government, Learned Societies, and Other Organizations

- CRAWFORD, O. G. S. *Air Survey and Archaeology*. London: Ordnance Survey Professional Papers, No. 7, 1929.
- JOHNSON, GEORGE R. *Peru from the Air*. American Geographical Society Special Publication No. 12. Worcester: Commonwealth Press, 1960.
- JUDD, NEIL M. "Arizona's Prehistoric Canals from the Air." *Explorations and Field Work of the Smithsonian Institution in 1930*. Publication No. 3111. Washington: Government Printing Office, 1931. pp. 157-166.
- LEHMER, D. J. "Archaeological Investigations in the Oake Dam Area, South Dakota, 1950-51." *River Basin Surveys Papers*, No. 7. Bureau of American Ethnology, Bulletin 158. Washington, 1954.
- LEE, WILLIS T. *The Face of the Earth as Seen from the Air: A Study in the Application of Airplane Photography to Geography*. New York: American Geographical Society Special Publications No. 4, 1922.
- Manual on the Technique of Archaeological Excavations*. Paris: International Institute of Intellectual Cooperation (UNESCO), International Museums Office, 1940.
- MCKINLEY, A. C., AND WELLS, H. R. "Photos of Cahokia Mound." *Explorations and Field Work of the Smithsonian Institution, 1921*. Washington: Government Printing Office, 1921. pp. 101-104.
- PHILLIPS, PHILIP. FORD, JAMES A., AND GRIFFIN, JAMES B. *Archaeological Survey in the Lower Mississippi Alluvial*

- Valley, 1940-1947. Papers of the Peabody Museum of American Archaeology and Ethnology, XXV. Cambridge: Harvard University, 1951.
- RICH, J. I. *The Face of South America, an Aerial Traverse*. New York: American Geographical Society Special Publication No. 26, 1942.
- ROBERTS, F. H. H., JR. "River Basin Surveys," in Appendix 5, Report of the Bureau of American Ethnology, *Annual Report of the Smithsonian Institution, 1953*. Washington: Government Printing Office, 1954. pp. 60-62.
- SOLECKI, RALPH S. *Appraisal of the Archaeological Resources of the Cheatham and Old Hickory Reservoirs on the Cumberland River in Central Tennessee*. River Basin Survey, Smithsonian Institution. Washington: Government Printing Office, 1954.
- . *Appraisal of the Archeological Resources of the Glen Eder Reservoir, Mitchell and Osborne Counties, Kansas*. Missouri Basin Project, Smithsonian Institution. Washington: Government Printing Office, 1952.
- . "Photographing the Past", *Missouri River Basin Progress Report, September, 1952*. United States Department of the Interior, Interior Missouri Basin Field Committee. Billings: 1952.
- WALFORD, A. D. *Regional Air Photo Interpretation in an Old Land, the Staffershire Potteries*. Department of Geography, University of British Columbia, 1962.
- WEDEL, W. R. "Prehistory and the Missouri Development Program." Summary Report on the Missouri River Basin Archeological Survey in 1948, *River Basin Survey Papers, No. 1, Bureau of America Ethnology, Bulletin 154*. Washington: 1953. pp. 1-159.
- WILLEY, GORDON R. *Prehistoric Settlement Patterns in the Viru Valley, Peru*. Smithsonian Institution Bulletin No. 155. Washington: Government Printing Office, 1953.
- CHART, D. A. "Air Photography in Northern Ireland," *Antiquity*, IV (December, 1930), 453-459.
- CHEVALIER, R. "Bibliographie des Applications Archeologiques de la Photographie Aerienne." Bulletin d'Archeologie Marocaine, Tome II (Supplement). Edita-Casablanca, 1957.
- CLARK, A. H. "Geographical Change as a Theme For Economic History," *Journal of Economic History*, XX (December, 1960), 607-617.
- CRAWFORD, O. G. S. "Air Reconnaissance of Roman Scotland," *Antiquity*, XIII (September, 1939), 280-292.
- . "A Century of Air Photography," *Antiquity*, XXVIII (December, 1954), 206-210.
- . "Durrington Walls," *Antiquity*, III (March, 1929), 49-59.
- . "The Mile Ditches at Royston," *Antiquity*, VIII (June, 1934), 216-218.
- . "Some Recent Air Discoveries," *Antiquity*, VII (September, 1933), 290-296.
- . "Woodbury," *Antiquity*, III (December, 1929), 452-455.
- CURWEN, E. CECIL. "Neolithic Camps," *Antiquity*, XII (March, 1930), 22-54.
- . "Prehistoric Agriculture in Britain," *Antiquity*, I (September, 1927), 261-289.
- DARBY, H. C. "The Changing English Landscape," *Geographical Journal*, CXVII (December, 1951), 377-398.
- . "Historical Geography, Twenty Years After," *Geographical Journal*, CXXVI (June, 1960), 147-159.
- DECKER, K. U. AND SCOLLER, I. "Iron Age Square Enclosures in Rhineland," *Antiquity*, XXXVI (September, 1962), 175-178.
- EDEINE, BERNARD "Une Méthode Pratique pour la Detection Aérienne des Sites Archéologiques, en Particulier par la Photographie sur Films en Couleurs et sur Films Infrarouges." *Bulletin de la Société Préhistorique Française*, LIII (1956), 540-546.
- FAGAN, B. M. "Cropmarks in Antiquity," *Antiquity*, XXXIII (December, 1959), 279-281.
- FORD, JAMES A. "Additional Notes on the Poverty Point Site in Northern Louisiana," *American Antiquity*, XIX (January, 1954), 282-285.
- GILBERT, E. W. "What is Historical Geography," *Scottish Geographical Magazine*, XLVIII (May, 1932), 129-136.
- GONZOLEY, ALBERTO REX "La Fotografía y el Reconocimiento Aéreo en las Investigaciones Arqueológicas del n. o. Argentino." *Anales de Arqueología y Etnológica*, XII (1956), 41-63.
- GOODCHILD, R. G. "Eneesperides-A Devastated City Site," *Antiquity*, XXVI (December, 1952), 208-212.
- HAWKES, CHRISTOPHER. "The Roman Camp Site Near Castor on the Nene" *Antiquity*, XIII (June, 1939), 178-190.
- . "The Roman Siege of Masada," *Antiquity*, III (June, 1929), 195-213.
- JUDD, NEH M. "Pyramids' of the New World," *National Geographic Magazine*, XCIII (January, 1948), 105-128.
- KEDAR, YEHUDA "Ancient Agriculture at Shivtah in the Negev," *Israel Exploration Journal*, VII, No. 3 (1957), 178-189.
- . "The Use of Aerial Photographs in Research in Physiographic Conditions and Anthropogeographic Data in Various Historic Periods," *Photogrammetric Engineering*, XXIV (December, 1958), 584-587.
- . "Water and Soil from the Desert: Some Ancient

## Periodicals

- AGACHE, R. "Aerial Reconnaissance in Picardy," *Antiquity*, XXXVIII (June, 1964), 113-119.
- ATKINSON, R. J. C. "The Dorset Circus", *Antiquity*, XXIX (March, 1955), 4-9
- BEAZELLY, G. A. "Air Photography in Archaeology," *Geographical Journal* LIII (May, 1919), 330-335.
- . "Surveys in Mesopotamia During the War," *Geographical Journal*, LV (February, 1920), 109-127.
- BERESFORD, M. W. "Maps and the Medieval Landscape," *Antiquity*, XXIV (September, 1950), 114-118.
- BRADFORD, JOHN "Buried Landscapes in Southern Italy," *Antiquity*, XXIII (June, 1949), 58-72.
- . "Etruria from the Air," *Antiquity*, XXI (June, 1947), 74-83.
- . "Progress in Air Archaeology," *Discovery*, XIII (June, 1952), 177-181.
- . "A Technique for the Study of Centuriation," *Antiquity*, XXI (December, 1947), 197-204.
- CAMERON, H. I. "History from the Air," *Photogrammetric Engineering*, XXIV (June, 1958), 366-375.
- CARTER, GEORGE "Archeology as Human Geography," *Geographical Review*, I (January, 1960), 122-125.
- CASSAN, STANLEY "Archaeology from the Air," *Scientific American*, C1 V (September, 1936), 130-132.

- Agricultural Achievements in the Central Negev," *Geographical Journal*, CXXIII (June, 1957), 179-187.
- KELLEY, A. R. "Etowah, Ancient Cult Center in Georgia," *Archaeology*, VII (Spring, 1954), 22-27.
- KOSAK, PAUL, AND REICHE, MARIA. "Thy Mysterious Markings of Nazca," *Natural History*, LVI (May, 1947), 200-207, 237-238.
- KRUSE, H. "A Remarkable Aerial Photograph of a Mandan Village Site," *Minnesota Archaeologist*, XIII (1942), 80-81.
- LEES, G. M., and FALCON, N. L. "The Geographical History of the Mesopotamian Plains," *Geographical Journal*, CXVIII (March, 1952), 24-39.
- MACDONALD, SIR GEORGE. "Rome in the Middle East," *Antiquity*, VIII (December, 1934), 373-380.
- MADERIA, PERCY C. "An Aerial Expedition to Central America," *Museum Journal*, XX, Museum of the University of Pennsylvania, (1931), 95-153.
- MILLER, WILLIAM C. "Uses of Aerial Photographs in Archeological Field Work," *American Antiquity*, XXIII (July, 1957), 46-52.
- MARGARY, IVAN DONALD. "Roman Camp Site Near Castor," *Antiquity*, XIII (December, 1939), 455-458.
- PEAKE, H. "An Ancient Trackway on the English Downs," *Geographical Review*, XXIX (July, 1939), 431-446.
- PIGGOTT, C. M. "The Grim's Ditch Complex in Cranborne Chase," *Antiquity*, XVIII (March, 1944), 65-71.
- PIGGOTT, STUART, AND PIGGOTT, C. M. "Stone and Earth Circles in Dorset," *Antiquity*, XIII (June, 1939), 138-158.
- RADFORD, C. A. RALIEGH. "A Roman Villa at Ditchley, Oxon," *Antiquity*, IX (December, 1935), 472-476.
- RAINEY, F., AND RALPH, E. K. "Archeology and its New Technology," *Science*, CLV (December, 1966), 1481-1491.
- REES, L. W. B. "The Transjordan Desert," *Antiquity*, XII (December, 1929), 389-407.
- REEVES, DACHE M. "Aerial Photography and Archaeology," *American Antiquity*, II (October, 1936), 102-107.
- RHODES, P. P. "The Celtic Field Systems of the Berkshire Downs," *Oxoniensia*, XV (March, 1959), 1-28.
- RICKETSON, OLIVER, JR., AND KIDDER, A. V. "An Archaeological Reconnaissance by Air in Central America," *Geographical Review*, XX (April, 1930), 177-206.
- RILEY, D. N. "Aerial Reconnaissance of the Fen Basin," *Antiquity*, XIX (September, 1945), 145-153.
- . "Archaeology from the Air in the Upper Thames Valley," *Oxoniensia*, VII-IX (1943-1944), 64-101.
- . "The Technique of Air Archaeology," *Archaeological Journal*, CI (March, 1944), 1-16.
- . "Groups of Circles in the Silt Fens," *Antiquity*, XX (September, 1946), 150-153.
- SAVILLE, MARSHALL H. "The Ancient Maya Causeways of Yucatan," *Antiquity*, IX (March, 1935), 67-73.
- SCHAEDEL, R. P. "The Lost Cities of Peru," *Scientific American*, CLXXXV (August, 1951), 18-23.
- SCOLLER, IRWIN. "A Neolithic Enclosure at Spiennes, Belgium," *Antiquity*, XXIX (September, 1955), 159-161.
- SETZLER, FRANK M. "Seeking the Secret of the Giants," *National Geographic Magazine*, CII (September, 1952), 390-404.
- SHIPPEE, ROBERT. "The 'Great Wall of Peru' and Other Photographic Studies by the Shippee-Johnson Peruvian Expedition," *Geographical Review*, XXII (January, 1932), 1-29.
- SOLECKI, RALPH S. "Considerations in the Interpretation of Aerial Views in Archaeology," *Photogrammetric Engineering*, XXIV (December, 1958), 798-802.
- . "Practical Aerial Photography for Archaeologists," *American Antiquity*, XXII (April, 1957), 337-351.
- STEVENS, C. E. "African Corn-Fields. A Review," of *Atlas des Centuriations Romaines de Tunisie*, Ministère des Travaux Publics, des Transports et du Tourisme. Paris: Institut Geographique National, 1954, in *Antiquity*, XXXII (March, 1958), 25-29.
- ST. JOSEPH, J. K. S. "Aerial Reconnaissance in Wales," *Antiquity*, XXXV (December, 1961), 263-275.
- . "Air Photography and Archaeology," *Geographical Journal*, CV (January, 1945), 47-61.
- . "Air Reconnaissance in Britain, 1951-55," *Journal of Roman Studies*, (1955), 82-91.
- . "Air Reconnaissance of North Britain," *Journal of Roman Studies*, (1951), 52-65.
- . "Air Reconnaissance in Northern France," *Antiquity*, XXVI (December, 1962), 279-286.
- . "Air Reconnaissance of South Britain," *Journal of Roman Studies*, XLIII (1953), 81-97.
- STRANDBERG, CARL H. "Ancient Indian Fishtraps in the Potomac River," *Photogrammetric Engineering*, XXVIII (July, 1962), 475-478.
- TATOR, BEN A. "Some Applications of Aerial Photographs to Geographic Studies in the Gulf Coast Region," *Photogrammetric Engineering*, XVII (December, 1951), 716-725.
- WILLIAMS-HUNT, P. "Archeology from the Air in Southeast Asia," *Journal of the Siam Society*, (June, 1949), 3-8.
- . "Irregular Earth Works in Eastern Siam: An Air Survey," *Antiquity*, XXI (March, 1930), 30-36.
- ZAMMIT, T. "Prehistoric Cart-tracks in Malta," *Antiquity*, II (March, 1928), 18-25.

## Essays and Articles in Collections

- BOWEN, H. C. "Airphotos and the Study of Ancient Fields in England," *Proceedings of the International Symposium on Photointerpretation*, held at Delft, Netherlands, September, 1962.
- CLARK, ANDREW H. "Historical Geography," *American Geography: Inventory and Prospect*, Preston E. James and Clarence F. Jones (eds). Syracuse: Syracuse University Press, 1954. pp. 70-105.
- COLWELL, ROBERT N. "Uses and Limitations of Multispectral Remote Sensing," *Proceedings of the Fourth Symposium on Remote Sensing of Environment*, held at the University of Michigan, Institute of Science and Technology, April, 1966.
- ESTES, JOHN E. "Some Geographic Applications of Aerial Infrared Imagery," *Proceedings of the Fourth Symposium on Remote Sensing of Environment*, held at the University of Michigan, Institute of Science and Technology, April, 1966.
- HARRELL, DAVID E., CRAWFORD, NICHOLAS C., AND PEPLIES, ROBERT W. "Remote Sensor Returns as Historical Documents," *Proceedings of the Fourth Symposium on Remote Sensing of Environment*, held at the University of Michigan, Institute of Science and Technology, April, 1966.
- ROWE, J. H. "Technical Aids in Anthropology: A Historical Survey," *Anthropology Today*, prepared under the chairmanship of A. L. Kroeber. Chicago: University Press, 1953. pp. 895-940.

- SMITH, C. J. "Historical Geography: Current Trends and Prospects," *Frontiers in Geographical Teaching*. Richard J. Chorley and Peter Haggett, (eds). London: Methuen and Company Ltd., 1965. pp. 118-143.
- SOJECKI, RALPH S. "Photo Interpretation in Archaeology," *Manual of Photographic Interpretation*. Washington: American Society of Photogrammetry, 1960. pp. 717-733.
- ST JOSEPH, J. K. S. "A Survey of Pioneering in Air-Photography," *Aspects of Archaeology in Britain and Beyond*, Essays Presented to O. G. S. Crawford, W. L. Grimes (ed.). London: H. W. Edwards, 1951. pp. 303-315.
- . "Air Photography and Archeology in Britain: Recent Studies," *Proceedings of the International Symposium on Photointerpretation*, held at Delft, Netherlands, September, 1962.

### Unpublished Materials

- HARP, ELMER, JR. "Experimental Air Photo Interpretation in Archaeology." Paper read at the American Society of Photogrammetry 1967 Convention, March 5-10, 1967.
- PRENTICE, VIRGINIA L. "Contributions of Air Photo Interpretation to the Study of the History of Man." Paper read at the American Society of Photogrammetry 1967 Convention, March 5-10, 1967.
- STRANDBERG, CARI H. "Archaeological Findings with Color Aerial Photography." Paper read at the American Society of Photogrammetry 1967 Convention, March 5-10, 1967.

### Newspapers

- BRADFORD, JOHN "Mapping Two Thousand Tombs from the Air: How Aerial Photography Plays its Part in Solving the Riddle of the Etruscans," *Illustrated London News*, CCXXVIII (June 16, 1956), pp. 736-738.



# Glossary

**Aerial Photograph, Oblique:** A photograph taken with the camera axis intentionally directed between the horizontal and the vertical. Commonly referred to as an oblique.

a. High oblique: an oblique photograph in which the apparent horizon is shown.

b. Low oblique: an oblique photograph in which the apparent horizon is not shown.

**Aerial Photograph, Vertical:** An aerial photograph made with the optical axis of camera approximately perpendicular to the surface of the earth.

**Aerial Photography, Composite:** Aerial photographs made with a camera having one principal lens and two or more surrounding and oblique lenses symmetrically placed. The several resulting photographs may be rectified in printing to permit assembly as verticals with the same scale.

**Air Base (photogrammetry):** The line joining two air stations or the length of this line; also, the distance (at the scale of the stereoscopic model) between adjacent perspective centers as reconstructed in the plotting instrument.

**Altitude:** Height of a point or object in space above a datum plane.

**Altitude, Absolute:** Height above the surface of the earth as differentiated from altitude (height above sea level). It is sometimes referred to as radar or radio altitude.

**Anaglyph:** A stereogram in which the two views are printed superimposed in complementary colors. Red and green have been universally used for this purpose. Since a picture of one pure color disappears when viewed through a glass of the same color, the views can be rendered mutually exclusive by a pair of spectacles in which one lens is red and one green. The light spaces

in the scene appear in both views and the complementary colors fuse to appear white. (See Vectograph.)

**Angle of Coverage:** The apex angle of the cone of rays passing through the front nodal point of a lens. Lenses generally are classified according to their angle of coverage, as follows:

Narrow-angle—Less than 60°.

Normal-angle—60° to 75°.

Wide-angle—75° to 100°.

Super-wide-angle or ultra-wide-angle—greater than 100°.

**Angle of Depression (camera):** The angle between the axis of an obliquely mounted aerial camera and the horizontal. This is the complement of the tilt angle.

**Angle of Field:** A property of a lens. The angle subtended by lines that pass through the center of the lens and locate the diameter of the maximum image area within the specified definition of the lens. Also called angular field.

**Annotated Print:** Reproduced imagery on which the interpreter has indicated details by words or symbols.

**Annotations:** Markings placed on imagery or drawings for explanatory purposes. Annotations are used to indicate items or areas of special importance.

**Antenna (radar):** That device which directs and transmits the energy from the radar transmitter and receives the energy reflected from the target.

**Anti-Vignetting Filter:** A filter bearing a deposit graduated in density to correct for the uneven illumination given by certain lenses, particularly wide angle types.

**Aperture, Relative:** The ratio of the equivalent focal length to the diameter of the entrance pupil

of a photographic lens. Expressed f:4.5, etc. Also called f-number, stop, aperture stop, diaphragm stop, or speed.

**Azimuth:** The direction of a line given as an angle measured clockwise from a reference direction, usually north.

**Base, Photo:** The distance between the principal points of two adjacent prints of a series of vertical aerial photographs. It is usually measured on one photograph after transferring the principal point of the other print.

**Blackbody (infrared):** A hypothetical object which absorbs all, and reflects none, of the radiation incident on its surface. A blackbody is also the perfect emitter. As the name implies, a blackbody can usually be approximated by black, sooty surfaces.

**Camera Calibration:** The determination of the focal length, the lens distortion in the focal plane, and the location of the principal point with respect to the fiducial marks. The settings of the fiducial marks and the positioning of the lens are ordinarily considered as adjustments, although they are sometimes performed during the calibration process. In a multiple-lens camera, the calibration also includes the determination of the angles between the component units.

**Camera Magazine:** The removable part of a camera in which the unexposed and exposed portions of film are contained.

**Camera Station:** The point in space, in the air, or on the ground occupied by the camera lens at the moment of exposure. Also called the exposure station. In aerial photogrammetry, the camera station is called the air stations.

**Camera, Stereometric:** A combination of two cameras mounted with parallel optical axes on a short, rigid base, used in terrestrial photogrammetry for taking photographs in stereoscopic pairs.

**Comparative Cover:** Cover of the same area or object taken at different times to show any changes in detail.

**Contact Print:** A print made from a negative or a diapositive in direct contact with sensitized material.

**Contrast:** The actual difference in density between the highlights and the shadows on a negative or positive. Contrast is not concerned with the magnitude of density, but only with the difference in densities. Also, the rating of a photographic material corresponding to the relative

density difference which it exhibits.

**Control:** A system of accurate measurements used to determine the distances and directions or differences in elevation between points on the earth.

**Control, Horizontal:** Control which determines horizontal positions only, as with respect to parallels and meridians or to other lines of reference.

**Control, Vertical:** Control which determines positions with respect to elevation.

**Controlled Mosaic:** A mosaic made of aerial photographs corrected for scale, rectified, and laid to ground control to provide an accurate representation of distances and direction.

**Crab (aerial photography):** The condition caused by failure to orient the camera with respect to track of the airplane, indicated in vertical photography by the sides of the photographs not being parallel to the principal-point base line. (See Drift.)

**Crab (air navigation):** Any turning of an airplane which causes its longitudinal axis to vary from the track of the plane. (See Drift.)

**Crown Closure:** A photo measure or estimate of the density of a forest stand. As seen on the vertical photograph, crown closure is the percentage of ground area occupied by tree crowns.

**Datum:** A reference element, such as a line or plane, in relation to which the positions of other elements are determined. Also called the reference plane or datum plane.

**Densitometer:** A device for measuring the density of a negative. The instrument measures the magnitude of the light transmitted through the exposed and developed film.

**Depth of Field:** The distance between the points nearest to and farthest from the camera which are acceptably sharp.

**Diapositive:** A positive photograph on a transparent medium.

**Displacement, Image:** Any dimensional change in a photograph reducing its usefulness as a true representation of the perspective conditions. It may result from imperfections in the optical system or in the sensitive material. Commonly used to denote the change of position of an image which occurs as the result of relief and tilt.

**Displacement, Relief:** The difference in the position of a point above or below the datum, with respect to the datum position of that point, owing to the perspective of an aerial photograph.

Relief displacement is radial from a point on the photograph corresponding to the ground position vertically beneath the camera. In vertical photography, relief displacement is radial from the principal point of the photograph. Also called relief distortion.

**Distance, Hyperfocal:** The distance from the lens of a camera to the nearest object in focus when the lens is focused at infinity.

**Distance, Interocular:** The distance between centers of rotation of the eyeballs of an individual. Used interchangeably with interpupillary distance.

**Distance, Principal:** The perpendicular distance from the internal perspective center to the plane of a particular finished negative or print. This distance is equal to the calibrated focal length corrected for both the enlargement or reduction ratio and the film or paper shrinkage or expansion. It maintains the same perspective angles from the internal perspective center to points on the finished negative or print as existed in the camera at the moment of the exposure. This is a geometrical property of each particular finished negative or print.

**Dodging (photographic):** The process of holding back light from certain areas of the sensitized paper in making a print, in order to avoid overprinting those areas. In projection printing, it is accomplished by inserting an opaque medium of proper shape and size between the lens and the easel, and in contact printing either by varying the illumination in given areas of the negative or by inserting translucent or opaque paper between the light source and the negative. Dodging may also be performed automatically by means of specially designed electronic or fluorescent printers.

**Drift (air navigation):** The horizontal displacement of an aircraft, caused by the action of the wind, from the track it would have followed in still air.

**Drift (aerial photograph):** Sometimes used to indicate a special condition of crab wherein the photographer has continued to make exposures oriented to the predetermined line of flight while the airplane has drifted with the wind. (See Crab.)

**Effective Area:** For any aerial photograph that is one of a series in a flight strip, that central part of the photograph delimited by the bisectors of overlaps with adjacent photographs. On a verti-

cal photograph, all images within the effective area have less displacement than their conjugate images on adjacent photographs.

**Electromagnetic Radiation:** Energy emitted or reflected in the form of electromagnetic waves which include, in order of increasing wavelength, cosmic rays, gamma rays, X-rays, ultraviolet radiation, visible light, infrared radiation, microwave radiation, and radio waves.

**Electromagnetic Spectrum:** The total frequency range of electromagnetic radiation. (See Electromagnetic Radiation.)

**Elevation:** Vertical distance from the datum, usually mean sea level, to a point or object on the surface of the earth. Not to be confused with altitude, which refers to points or objects above the surface of the earth.

**Emissivity:** The ratio of radiation emitted by a surface to the radiation emitted by a blackbody at the same temperature and under the same conditions. This may be expressed for the total radiation from all wavelengths or for restricted bands of wavelengths. Targets are described in terms of their apparent emissivity. The following categories are generalized target descriptions (assuming a target and its background have the same emissivity):

a. **Warm Target:** A target that is warmer than its background will image lighter than its background on the film (positive).

b. **Hot Target:** A target that is much warmer than its background will image much brighter than its background.

c. **Cool Target:** A target that is cooler than its background will image darker than its background.

d. **Cold Target:** A target that is much colder than its background will image much darker than its background.

**Emulsion (photographic):** A suspension of a light-sensitive silver salt, usually silver chloride or silver bromide, in a colloidal medium, usually gelatin, used for coating photographic films, plates, or paper.

**Exposure (photographic):** The function of the duration of time and the intensity of illumination upon photographic material.

**Ferrottype:** To give a gloss to a photographic print by squeegeeing facedown while wet on a polished plate and allowing to dry.

**Fiducial Marks:** Index marks, rigidly connected with the camera lens through the camera body,

which form images on the negative. The marks are adjusted so that the intersection of lines drawn between opposite fiducial marks defines the principal point.

**Film:** A thin, flexible, transparent sheet coated with light-sensitive emulsion, for use in the camera. Formerly, the skin of sensitive material alone.

**Film Base (photography):** A thin, flexible, transparent sheet of stable plastic material which is coated with a light-sensitive emulsion and used for taking photographs.

**Filter (infrared sensor):** An optical material inserted in the infrared system in front of the detector; it limits the radiation to that between the specified wavelengths.

**Filter (optical):** A transparent material used in the optical path of a camera lens to absorb a certain portion of the spectrum and prevent its reaching the sensitized negative.

**Filter Factor:** The amount that film exposure must be increased to offset the reduction in light resulting from the use of a filter. A filter absorbs part of the light passing through it; therefore, less light reaches the film. The lens diaphragm must be opened wider or the shutter longer for correct exposure of the film. A filter factor of 2 means that the normal exposure must be doubled.

**Flight Line:** A line drawn on a map or chart to represent the track of an aircraft.

**Floating Mark (photogrammetry):** A mark seen as occupying a position in the three dimensional space formed by the stereoscopic fusion of a pair of photographs and used as a reference mark in examining or measuring the stereoscopic model. The mark may be formed (1) by one real mark lying in the projected object space, (2) by two real marks lying in the projected or virtually projected spaces of the two photographs, (3) by two real marks lying in the planes of the photographs themselves, and (4) by two virtual marks lying in the image planes of the binocular viewing apparatus.

**Focal Length:** The distance measured along the lens axis from the rear nodal point to the plane of best average definition over the entire field used in the aerial camera.

**Focal Plane (aerial photography):** The plane (perpendicular to the axis of the lens) in which images of points in the object field of the lens are focused.

**Format:** Actual size of negative, oscilloscope, or

other medium on which an image is produced.

**Form Lines:** Lines drawn to represent the shape of terrain; unlike contour lines, they are drawn without regard to a true vertical datum or regular interval.

**Frame:** An individual exposure contained in a continuous sequence of imagery.

**Gamma (photography):** A numerical measure of the extent to which a negative has been developed, indicating the proportion borne by the contrast of the negative to that of the subject on which it was exposed. The numerical figure for gamma is the tangent of the straight-line (correct exposure) portion of the curve resulting from plotting exposure against density. A gamma of 1.0 indicates a negative which has the same contrast as the subject photographed. A gamma of 1.2 indicates a negative which has greater contrast than the subject photographed.

**Generation:** The number of reproductive steps in which a negative or positive photographic copy is separated from the original. Thus, the original negative would be the first generation; any positive made from the original negative would be the second generation copy; and duplicate negative made from a second generation positive would be a third generation copy, and any positive made from the third generation negative would be a fourth generation copy.

**Grainy:** Characterized by a lack of smoothness of the silver deposit, caused by clumps or groups of particles. Excessive graininess reduces quality, especially when magnified or enlarged.

**Ground Resolution:** The ground size equivalent of the smallest resolvable image and its associated space, usually expressed in feet per side.

**Halation:** A spreading of light beyond its true boundaries from bright parts of a photographic image into adjacent darker parts as a result of reflection from the back surface of the film or plate.

**Haze:** A lack of transparency of the atmosphere, caused by the presence of foreign matter, such as dust, fog, or smoke.

**Image:** Representation of an object on any medium by optical or electronic means.

**Image Interpretation:** The use of systems, techniques, or processes of analyzing imagery in order to produce significant, reliable, and detailed information concerning the natural or cultural features of the area imaged and to determine or infer the factors which the observable

presence, conditions, or use of these features imply.

**Imagery:** Images collectively. Produced electronically or by optical means on film, electronic display devices, or other media.

**Index, Photo:** An index map made by assembling the individual photographs into their proper relative positions and copying the assembly photographically at a reduced scale.

**Infrared Imagery:** That imagery produced as a result of sensing electromagnetic radiations emitted from a given target surface in the infrared portion of the electromagnetic spectrum.

**Infrared Radiation:** Energy emitted or reflected in the form of electromagnetic radiation. Wavelengths of infrared radiation range from 0.72 microns to about 1,000 microns (1 millimeter) and are frequently divided, in order of increasing wavelength, into near, middle, and far infrared. (See Electromagnetic Radiation.)

**Intervalometer:** A timing device for automatically operating the shutter of a camera at regular intervals.

**Inverted Stereo:** A three-dimensional impression of relief which is the reverse of that actually existing.

**Iris Diaphragm:** A continuously variable circular aperture in a lens which makes it possible to control the amount of light passing through the lens. Also called a stop.

**Isocenter:**

a. The unique point common to the plane of a photograph, its principal plane, and the plane of an assumed truly vertical photograph taken from the same camera station and having an equal principal distance.

b. The point of intersection on a photograph of the principal line and the isometric parallel.

c. The point on a photograph intersected by the bisector of the angle between the plumb line and the photograph perpendicular. The isocenter is significant because it is the center of radiation for displacements of images owing to tilt.

**Key, Image Interpretation:** A device or other reference material designed to aid image interpreters in the rapid, accurate identification of an object from the study of its image.

**Lens:** A piece, or combination of pieces, of glass or other transparent material shaped to form an image by changing the direction of rays of light.

**Lens Assembly:** A complete unit composed of lens elements, diaphragm, and lens barrel.

**Map, Flight:** A map on which are indicated the desired lines of flight and/or positions of exposure for the taking of aerial photographs, or the map on which are plotted, after photography, selected air stations and the tracks between them.

**Map, Planimetric:** A map which presents only the horizontal positions of represented features; distinguished from a topographic map by the omission of relief in measurable form. The natural features usually shown on a planimetric map include rivers, lakes, seas, mountains, valleys, marshes, plains, forests, prairies and deserts. The cultural features include cities, farms, transportation routes, public utility facilities, and political and private boundaries. A planimetric map intended for special use may present only those features which are essential for its purpose.

**Map, Topographic:** A map which presents relief or the vertical position of features, as well as their horizontal positions, in measurable form.

**Microwave:** A very short electromagnetic wave; any circuitry-produced wave shorter than about 30 centimeters in wavelength.

**Milliradian (infrared):** One thousandth of a radian. It is approximately the angle subtended by an arc 1 foot in length at 1,000 feet and is the basic factor in determining ground resolution of a given system.

**Mosaic, Controlled:** A mosaic made of aerial photographs corrected for scale, rectified and laid to ground control to provide an accurate representation of distances and direction.

**Mosaic, Semi-controlled:** A mosaic composed of uncorrected vertical aerial photographs laid to a limited ground control.

**Mosaic, Uncontrolled:** A mosaic composed of uncorrected prints, the detail of which has been matched from print to print without ground control or other orientation.

**Multispectral Imagery:** That imagery which is produced as a result of combining two or more types of sensings on a single image format, thus producing a compound target image such as infrared (camouflage detection) film.

**Nadir:** That point on the celestial sphere directly beneath the observer and directly opposite the zenith.

**Nadir, Photograph:** The point at which a vertical line through the perspective center of the camera lens pierces the plane of the photography.

**Negative:** (1) A photographic image on film, plate, or paper, in which the tones are reversed. (2) A film, plate, or paper containing such a reversed image.

**Orthostereoscopy:** A condition wherein the horizontal and vertical distances in a stereoscopic model appear to be at the same scale.

**Overexposure:** The result of too much light being permitted to act on a light-sensitive material, with either too great a lens aperture or too slow a shutter speed or both. Results in excessive image density.

**Overlap:** The amount by which one photograph includes the area covered by another photograph, usually expressed as a percentage. The overlap between successive aerial photographs on a flight line is called forward overlap. The overlap between photographs on adjacent parallel flight lines is called sidelap.

**Orientation, Relative:** The determination (analytically or with a photogrammetric instrument) of the position and altitude of one of a pair of overlapping photographs with respect to the other photograph.

**Pair, Overlapping (photographic):** Two photographs taken at different exposure stations in such a manner that a portion of one photograph shows the same terrain which appears on a portion of the other photograph. The term covers the general case and does not imply that the photographs were taken for stereoscopic examination. (See Stereoscopic Pair.)

**Parallax, Absolute:** In a pair of truly vertical photographs which have equal principal distances and are taken from equal flight heights, or in a pair of rectified photographs, the term denotes the algebraic difference, parallel to the air base, of the distances of the two images from their respective principal points. Also called x-parallax.

**Parallax Difference:** The difference in the absolute parallaxes of two points imaged on a pair of photographs. Customarily used in determination of the difference in elevation of objects.

**Parallax Wedge:** A simplified stereometer for measuring object heights on a stereoscopic pair of photographs. It consists of two slightly converging rows of dots or graduated lines printed on a transparent template which can be stereoscopically fused into a single row or line for making parallax measurements to the nearest 0.002 inch.

**y-Parallax (photogrammetry):** The difference between the perpendicular distances of the two images of a point from the vertical plane containing the air base. The existence of y-parallax is an indication of tilt in either or both photographs and/or a difference in flying height and interferes with stereoscopic examination of the pair. Also called want of correspondence and vertical parallax, though the latter is not preferred.

**Pass Point:** A point whose position is determined from photographs by photogrammetric methods and which is intended for use after the manner of a ground control point in the orientation of other photographs.

**Passive Sensor:** A sensor which collects radiation emitted from another source, such as daylight and infrared energy.

**Pattern:** In a photo image, the regularity and characteristic placement of tones or textures. Some descriptive adjectives for patterns are regular, irregular, random, concentric, radial, and rectangular.

**Photogrammetry:** The science or art of obtaining reliable measurements by means of photography.

**Plan Position Indicator (PPI):** A radar indicator with a rotating time base line which provides a map-like presentation of the terrain below the aircraft.

**Plane:** A surface, real or imaginary, in which if any two points are taken, the straight line that joins them lies wholly in that surface; or, a surface any intersection of which by a like surface is a straight line.

**Power, Resolving:** A mathematical expression of lens definition, usually stated as the maximum number of lines per millimeter that can just be resolved, that is, seen as separate lines in the image. Often used interchangeably with resolution.

**Principal, Point:** The foot of the perpendicular from the interior perspective center to the plane of the photograph; that is, the foot of the photograph perpendicular. (See Fiducial Marks.)

**Print, Ratio:** A print whose scale has been changed from that of the negative by photographic enlargement or reduction.

**Print, Semimatte:** A print approximately intermediate in glossiness between a matte and a glossy print.

**Print, Transformed:** A photographic print made by projection in a transforming printer. (See

Rectification.)

**Projector, Map:** A specially designed optical instrument by means of which the image of a photograph or a drawing is projected onto a table where it can be traced or compared with another drawing. The instrument is usually equipped with a mirror to erect the projected image and is always arranged so that the scale of the projected image can be varied. The instrument does not provide for the rectification of the photograph.

**Radar:** The science of locating and/or identifying distant objects by means of radio techniques. Radar depends on two processes; one, the reflection of radio waves by material bodies, and the other, the use of short pulses of high frequency energy to make possible the accurate measurement of distance.

**Radar Resolution:** (1) Range Resolution: The minimum size of objects and the space between them that will show as separate returns on the radarscope when one object is farther than the other in range. (2) Track Resolution (Azimuth): The minimum size of objects and the space between them that will show when the targets are aligned parallel to the flight path.

**Range, Slant (SR):** The distance measured along the line of sight from the aircraft to an object on the ground.

**Raster:** A two-dimensional scan presentation on a cathode ray tube.

**Ratio Print:** A print the scale of which has been changed from that of the negative by photographic enlargement or reduction.

**Rectification:** The mathematical, optical-mechanical, or graphical procedure by which a tilted aerial photograph is converted into one having no tilt.

**Representative Fraction (R.F.):** The relationship between map or image distance and ground distance, expressed as a fraction (1/25,000) or often as a ratio (1:25,000) (1 inch on map = 25,000 inches on ground). Also called scale.

**Resolution (photographic):** The ability of the entire photographic system, including lens, exposure, processing, and other factors, to render a sharply defined image. It is expressed in terms of lines per millimeter recorded by a particular film under specified conditions. (See Radar Resolution.)

**Resolving Power:** A mathematical expression of lens definition, usually stated as the maximum number of lines per millimeter that can be re-

solved (that is, seen as separate lines) in the image.

**Scale, Gray:** A term used to describe the various tonal graduations on an imagery recording.

**Scanner (infrared):** An optical-mechanical image-forming device that receives electromagnetic radiation from objects during successive scans across the plane of the object. It converts the radiation to electrical signals that subsequently modulate the output of light from a recording device to form a photographic image of the relative levels of radiation in the scanned scene.

**Sensitivity, Color (photography):** The sensitivity of a photographic emulsion to light of various wavelengths.

**Sensitometry:** The measurement of the response of a photosensitive material to the action of light.

**Sensor:** A technical means to extend man's natural senses; an equipment which detects and indicates terrain configuration, the presence of military targets, and other natural and man-made objects and activities by means of energy emitted or reflected by such targets or objects. The energy may be nuclear, electromagnetic including the visible and invisible portions of the spectrum, chemical, biological, thermal, or mechanical, including sound, blast, and earth vibration.

**Shutter:** The mechanism of a camera which, when set in motion, permits light to reach the sensitized surface of the film or plate for a predetermined length of time.

**Shutter, Between the Lens:** A shutter located between the lens elements of a camera; usually consisting of thin metal leaves which open and close or revolve to make the exposure.

**Shutter, Focal-Plane:** A shutter located near the focal plane; usually consisting of a curtain with a slot which is pulled across the focal plane to make the exposure.

**Side Looking Airborne Radar (SLAR):** An airborne radar that produces an image of a portion of the surface of the earth by means of one or more antennas viewing at approximately right angles to the longitudinal axis of the aircraft.

**Sidelap:** See Overlap.

**Signature:** That physical feature or pattern of physical features by which a target can be recognized on imagery.

**Solar Angle (Sun Altitude):** Usually expressed in degrees referring to the angular position of the sun above the horizon. If the solar angle is less than 30 degrees, deep shadows will be encoun-

tered in aerial photography.

**Speed, Emulsion (photography):** A measure of the sensitivity of the emulsion. It determines the exposure required to produce the desired image.

**Stereogram:** A set of photographs or drawings correctly oriented and mounted for stereoscopic viewing.

**Stereographic Coverage:** Photographic coverage with overlapping aerial photographs to provide a three-dimensional presentation of the picture; 60-percent overlap is considered normal and 53-percent is generally regarded as the minimum.

**Stereometer:** A stereoscope with special attachments for measuring parallax. Also called stereocomparator.

**Stereoscope:** A binocular optical instrument for assisting the observer to view two properly oriented photographs or diagrams to obtain the mental impression of a three-dimensional model.

**Stereoscopic Image:** That mental impression of a three-dimensional object which results from stereoscopic vision.

**Stereoscopic Pair:** Two photographs with sufficient overlap and consequent duplication of detail to make possible stereoscopic examination of an object or an area common to both.

**Stereoscopic Plotting Instrument:** Any instrument for plotting a map or obtaining spatial solutions by observation of stereoscopic models formed by stereo-pairs of photographs.

**Stereoscopic Vision (Stereo Vision):** That application of binocular vision which enables the observer to view an object simultaneously from two different perspectives (as two photographs taken from different camera stations) to obtain the mental impression of a three-dimensional model.

**Stereoscopy:** The science or art which deals with three-dimensional effects and the methods by which these effects are produced.

**Template:** (1) A pattern or guide used to shape, delimit, or locate an area. (2) A device used in radial triangulation to represent the aerial photograph; the template provides a record of the directions of radials taken from the photograph.

**Template, Slotted:** A mechanical template on which the radials are represented by slots cut in a sheet of cardboard, metal, or similar material.

**Texture (photography):** In a photo image, the frequency of change and arrangement of tones. Some descriptive adjectives for textures are fine, medium or coarse, and stippled or mottled.

**Thermal Imagery (infrared):** Imagery produced by measuring and recording electronically the thermal radiation of objects.

**Tilt, Axis of:** The line through the perspective center perpendicular to the principal plane. The term is arbitrarily restricted to this definition. The axis of tilt could be any one of several lines in space, for example, the isometric parallel or the ground line; but the present definition is the only one which permits the concept of tilting the photograph without upsetting the positional elements or exterior orientation.

**Tilt, Relative:** In a nearly vertical photograph, the tilt of the photograph with reference to an arbitrary plane, not necessarily a horizontal plane, such as the preceding or subsequent photograph in a strip.

**Tilt, x- and y-:** Tilt expressed as resultant rotations about each of two stationary rectangular axes lying in a horizontal plane, the x-tilt being the resultant rotation about the x-axis and the y-tilt the resultant rotation about the y-axis. In an aircraft, the x-axis is the longitudinal axis of the aircraft, lengthwise through the fuselage; the y-axis is the transverse axis, from wing tip to wing tip.

**Tone:** Each distinguishable shade variation from black to white.

**Ultraviolet Imagery:** That imagery produced as a result of sensing ultraviolet radiations emitted from a given target surface in the ultraviolet portion of the electromagnetic spectrum (shorter wavelengths than 0.4 microns).

**Underexposure:** The result of insufficient light being allowed to pass through the lens to produce all the tones of an image, or of sufficient light being allowed to pass for too short a period of time.

**Vectograph:** A stereoscopic picture whose three-dimensional effect is obtained by means of polarization. A vectograph has a blurred appearance to the eye, like that of a double exposure. The right-eye picture of a stereoscopic pair is prepared on polarized film with its polarization axis at 90 degrees to the axis of the left-eye film. The pictures, slightly offset, are placed on a transparent base. When the vectograph is examined through polaroid spectacles, the right eye sees only the right-eye picture and the left eye, the left-eye picture. Thus, the two are readily fused into a single three-dimensional impression. (See Anaglyph.)



**Vignetting Filter:** A filter which gradually decreases in density from the center toward the edges. It is used in certain cases, in photography or printing processes to produce a photograph of uniform density.

**Windows (infrared):** A piece of optical material used with a system to permit the passage of infrared radiation. The word "window" also is used to denote a region of the electromagnetic spectrum in which radiation is only slightly attenuated as it propagates through the atmosphere.

Source:

U.S. Departments of Army, Navy, and Air Force  
Image Interpretation Handbook, Vol. I.  
Government Printing Office, Washington, D.C.  
7 chapters, plus appendix, illus., 1967



# Index

- Absolute stereoscopic parallax, 22, 23  
Active sensors, 40  
Additive viewer, 44-46  
Aerial cameras, 4  
Aerial photography, 1, 64, 70, 82: as field mobility maps, 6, 54; as historical data, 1, 64, 65, 84; oblique, 1, 30, 31, 61, 71, 84; sources, 27-31; types, 1-2; vertical, 18, 30, 32, 61, 64, 71, 84, 86  
Aerographic film, 70  
Agricultural Stabilization and Conservation Service (ASCS), 27, 28  
Air base. *See* Photo base length  
Aircraft as camera platform, 2, 31, 53, 82  
Air Force, 27  
Altitude: flight, 38; effective, 16  
American Society of Photogrammetry, 30  
Annotation, photo, 35-36  
Archeology: feature delineation, 35; photogrammetry in, 68-83  
Archeological applications of photogrammetry, 55, 56, 81-83; planning, 81; intra-site maps, 55, 82; digitized data, 82, 83; hard access documentation, 82  
Archeological interpretation of remote sensor data, 53-67; demographic analysis, 62; ecological stratification, 64; excavation recording, 64; functional analysis, 62-64; relative age dating, 62; site prediction, 62; volumetric analysis, 64  
Architectural elevations, 69, 70, 71, 82  
Area coverage, 4-5, 28, 71; measuring methods, 20-21  
Areameters, 21  
Atlas sheet, 30  
Average photo scale, 14, 89  
Axis of tilt, 16, 18
- Balloons, 4  
Bar, parallax, 22, 23, 23, 25, 43  
Base length. *See* Photo base length.  
Basic interpretation skills, 53  
Beam-splitter, 36  
Binocular vision, 11  
Bipods, 4, 82
- Black-and-white film. *See* Panchromatic film.  
Black-and-white infrared film, 5, 86  
Black-and-white television monitor, 46  
Bridging, 71, 81  
Bureau of Land Management (BLM), 30
- Camera types: aerial, 4; hand-held, 4; light-weight military-reconnaissance, 31; metric or calibrated, 70; multiband, 7, 42, 44, 45; press, 31  
Camera Lucidas, 36  
Camera platforms, 2-4; aircraft, 2, 31, 53, 82; balloons, 4; bipods, 4, 82; helicopters, 2; tripods, 4, 82; spacecraft, 2  
Canadian government: imagery, 30; maps, 31, 33  
Captive balloons, 4  
Cartographic photogrammetry, 64, 70  
C-factor, 38, 71  
China-marking pencils for delineation, 36  
Closed-circuit television systems, 46, 46, 47  
Color film, 5, 6, 86  
Color infrared film, 5, 6, 7, 61, 73, 86  
Color perception, 49  
Color television monitor, 46, 76  
Commercial photography, 30  
Comparative imagery, 51  
Composite photographs, 1  
Computer applications: in image analysis, 41-47; in photogrammetry, 82, 83  
Contouring factor, 38, 71  
Contours, 34, 38, 54  
Contract photography inspection, 87, 88  
Control, ground. *See* Ground control.  
Controlled mosaics, 1, 30, 32  
Convergence of evidence, 59  
Conversion factors, 16, 17, 24, 25, 89  
Corps of Engineers, 27  
Cost factors, 86-87  
Coverage, 28, 71  
Crop marks, 53, 60, 61, 84, 86  
Cultural resource management, 64-65, 82

- Datum plane, 14, 20  
 Declination of sun, 86  
 Delineation of archeological features, 35  
 Demographic analysis, 62  
 Densitometer, 47  
 Density slicing, 54, 76  
 Diapositives, 38, 70  
 Difference in elevation, stereoscopic determination of, 20  
 Difference, parallax, 22, 23  
 Differential parallax, 22  
 Digitize: densities, 47; photogrammetric data, 82, 83  
 Displacement, 16-20; photo image, 16-18; relative image, 20; relief, 16, 18-20, 18, 19, 20, 32; tilt, 16, 18  
 Distortions, 16; relief, 16; tilt, 16  
 Dot grids, 21, 21
- Earth-orbiting spacecraft as camera platform, 2  
 Ecological stratification, 1, 64, 77, 79, 80, 82  
 Edge enhancer, 46-47, 54, 58  
 Effective altitude, 16  
 Electrical resistivity devices, 40  
 Electromagnetic spectrum, 5, 5, 40, 41  
 Electronic aids to image analysis, 44-47, 54; closed-circuit television systems, 46, 46, 47; color monitor, 46, 76; edge enhancer, 46-47, 54, 58; perspective monitor, 47; integrated television-densitometer-computer systems, 47; multispectral additive viewer, 44-46, 45  
 Elevation, architectural, 69, 70, 71, 82  
 Endlap. *See* Overlap.  
 Enlargement ratio of plotters, 70  
 Environmental maps, 1, 64, 77, 79, 80, 82  
 Equipment. *See* Remote sensing instruments, electronic aids to image analysis, stereoscopes.  
 EROS data center, 30  
 Error factors, 16  
 Exaggeration, vertical, 13, 32  
 Excavation recording, 4, 64, 82  
 Existing photography, sources of, 27-31, 86
- False color. *See* Color infrared film.  
 Familiarity with equipment and instruments, 54  
 Fiducial marks, 15  
 Field checking, 51, 64, 65  
 Field mobility maps, 6, 54  
 Field situation skills, 53  
 Field work in mapping, 38  
 Film sensitivity, 5  
 Film types, 5-7, 86; aerographic, 70; black-and-white infrared, 5, 86; color, 5, 6, 86; color infrared, 5, 6, 7, 61, 73, 86; near infrared, 6; modified infrared, 6; panchromatic, 5-6, 70, 86  
 Fixed-wing aircraft as camera platform, 2, 31, 53, 82  
 Flight altitude, 38  
 Flight line, 81; overlap, 11, 32, 36, 70; sidelap, 32, 36, 70  
 Flight planning, 61, 84  
 Floating dot or mark, 38  
 Focal length/altitude method of scale determination, 14, 15, 16  
 Forest Service, 27, 28  
 Form-line sketching, 38, 64  
 Formula, parallax, 22, 23  
 Functional analysis, 62
- Geological Survey, 27, 28, 30, 31, 31, 33, 38, 64, 65  
 Glass diapositives, 38, 70  
 Glossy prints, 27  
 Government agencies as sources of maps, 31; photography, 27-28, 30; ASCS, 27, 28; BLM, 30; Forest Service, 27, 28; Geological Survey, 27, 28, 30, 31, 31, 33, 38, 64, 65; SCS, 27, 28, 65; National Ocean Survey, 27  
 Ground Control: horizontal and vertical, 38, 71, 71, 81; panels, 71, 81, 82; points, 32, 38; photoidentification, 71  
 Ground coverage for stereograms, 71, 71  
 Ground stereograms, 4, 13
- Halation, light, 86  
 Hand-held cameras, 4  
 Hard access documentation, 82  
 Helicopters as camera platforms, 2  
 High altitude imagery, 30  
 High oblique, 1  
 Historical data: aerial photos as, 1, 64, 65, 84; maps as, 68  
 Hot spots, 86
- Image analysis. *See* Electronic aids to image analysis.  
 Image displacement. *See* Photo image displacement.  
 Image reading skills, 53  
 Image recognition key, 13, 51-52  
 Image resolution, 4-5  
 Imaging sensors: multispectral scanners, 1, 30, 42, 46, 47; television, 40-41; thermography, 1, 41, 42  
 Impact monitoring, 64-65, 82  
 Index mosaics, 28, 32  
 Index sheets, 28, 29, 30  
 Infrared, 5, 6, 7, 61, 73, 86; thermal, 1, 41-42, 42  
 Inspection of contract photography, 87, 88  
 Integrated television-densitometer-computer system, 47  
 Interpretation key, 13, 51-52  
 Interpretation skills, 53-54; basic, 53; field situation, 53; familiarity with equipment and instruments, 54; image reading skills, 53  
 Interpretation training, 51  
 Interpupillary distance, 11, 13  
 Intra-site maps, 82  
 Isocenter, 18

- K-20 camera, 31
- K-25 camera, 31
- Key, photointerpretation, 13, 51-52
  
- Lambert conformal conic projection, 33
- LANDSAT, 30, 43
- Lens separation for stereoscopic photography, 13
- Lens stereoscope, 11, 13
- Light halation, 86
- Light wavelength, 5
- Lightweight military-reconnaissance cameras, 31
- Linear scale, 14
- Local photographic coverage sources, 28
- Low oblique, 1
  
- Magnetic tape, 40
- Magnetometers, 40
- Magnifying stereoscope, 11
- Manual of Photogrammetry*, 18
- Map approximations: aerial photos as, 6, 54; mosaics as, 2, 32
- Map projections: Lambert conformal conic, 33; polyconic, 33, 38, 75; universal transverse Mercator, 33
- Maps: approximations, 2, 6, 32, 54; digitization, 82; existing, 33; historical records, 68; intra-site, 82; microtopographic, 81; planimetric, 16, 32, 38, 54, 64, 70, 81; substitutes, 32-33; topographic 31, 38, 58, 64, 70, 74, 75
- Metric cameras, 70
- Microtopographic site map, 81
- Minus-blue filter, 27, 86
- Mirror stereoscope, 11, 12, 23, 38
- Model. *See* Stereomodel.
- Modified infrared, 6
- Monitoring impact, 82; natural forces, 64-65; visitation, 64-65
- Monocular transfer, 36; disadvantage, 36
- Monocular vision, 9-11
- Mosaics, 1-2, 32, 58; controlled, 1, 30, 32; index, 28, 32; map approximations, 2, 32; ortho-photomosaics, 32, 33; semi-controlled, 32, 58; uncontrolled, 2, 32
- Multiband photography, 7, 42, 44, 45
- Multispectral additive viewer, 44-46, 45
- Multispectral scanners, 1, 30, 42, 43, 46, 47
  
- Nadir, 18, 19, 20, 32, 33
- NASA, 30
- National Air Photo Library of Canada, 30
- National Ocean Survey, 27
- Natural scale, 14
- Near infrared, 6
- Neat stereomodel, 71, 72
- Negative crop marks, 60, 61
- Nominal scale, 14, 20
- Non-cartographic photogrammetry, 70
- Nonimaging sensors: magnetometers, 40; radar, 1, 40, 41; radiometers, 40; resistivity, 40. scatterometers, 40; spectrometers, 40
- Nonphotographic sensors, 1, 40-42, 52, 84; ground-based radar, 40; multispectral scanners, 1, 42, 43; side-looking airborne radar, 1; television, 40-41; thermal scanners, 1, 41-42, 42
- Normal color film. *See* Color film
  
- Oblique photographs, 1, 13, 30, 31, 61, 71, 84
- Optical center, 15
- Orthophoto, 33, 34; mosaic, 32, 33; quads, 33
- Overlap, flight line, 11, 32, 36, 70
- Overlay maps, 59
  
- Panchromatic film, 5-6, 70, 86
- Panels, ground control, 71, 81, 82
- Pantograph, 36
- Parallax, 22-28; absolute stereoscopic, 22, 23; bar, 22, 23, 23, 25, 43; definition, 22; device, 22, 36, 38; difference, 22, 23; differential, 22; formula, 22, 23; wedge, 22, 23, 24
- Passive sensors, 40
- Patterns as photo interpretation factor, 9
- Penetration of soil and rock, 40
- Perspective television monitor, 47
- Perspective view, 19, 82
- Phase mapping, 64
- Phase photography, 4, 64, 82
- Photo annotation and delineation, 35-36
- Photo base length, 13, 20, 22, 24
- Photogrammetric Engineering and Remote Sensing*, 30
- Photogrammetry: archeological, 64, 68-83, 69; cartographic, 64, 70; general, 8, 84; non-cartographic, 70
- Photographic days per month, 85
- Photographic resolution, 4
- Photographs, 1-2; composite, 1; map substitutes, 6, 32-33, 54; mosaic, 1; oblique, 1, 13, 30, 31, 61, 71, 84; sources, 27-31, 86; taking your own, 30; terrestrial, 1, 2, 13, 71, 82; trimetrogon, 30; vertical, 1, 13, 14, 18, 30, 32, 61, 63, 64, 71, 82, 84, 86
- Photo/ground distance method of scale determination, 14-16, 15
- Photoidentification of ground control, 71
- Photo image displacement, 16-18
- Photo index sheets, 28, 29, 30
- Photo interpretation, 8-9, 9, 49-52; definition, 8, 49; factors, 8-9; field aids, 43-44; patterns, 9; shadow, 8, 53, 60; shape, 8; size, 8; surrounding objects, 8-9; texture, 9; tone, 9
- Photointerpretation key, 13, 51-52
- Photo mosaics. *See* Mosaics.
- Photo scale. *See* Scale.
- Planimeters, polar, 21
- Planimetric map, 16, 32, 38, 54, 64, 70, 81; digitization, 82

- Plant marks, 59-61, 84, 86
- Platforms, 2, 4, 53, 82
- Plotter. *See* Stereoplotter.
- Plumb point, 18, 19, 20, 32, 33
- Pocket stereoscope, 11, 43
- Points, ground control, 32, 38
- Polar planimeters, 21
- Polyconic projection, 33, 38, 75
- Positive crop marks, 60, 61
- Precision of height measurements, 24
- Principal distance of plotters, 71
- Principal point, 15, 16, 18, 33
- Projectors: camera lucidas, 36; direct, 36; reflecting, 36
- Proportionate grid systems, 36
- Pseudoscopic effect, 11
- Radar systems, 1, 40, 41
- Radial line plot, 33-35, 35
- Radial line triangulation, 33, 38
- Radiometers, 40
- Ratioed prints, 32, 33
- Recognition pattern, 53-54
- Rectified prints, 32, 33
- Reflectance, spectral, 5, 5
- Reflecting stereoscope, 11, 38
- Relative age dating, 62
- Relative image displacement, 20
- Relief displacement, 16, 18-20, 18, 19, 20, 32
- Remote sensing, 66; definition, 1; instruments. *See* Remote sensing instruments.
- Remote sensor imagery, 53; as historical data, 1, 64, 65, 84
- Remote sensing instruments, 65, 67; active, 40; magnetometers, 40; multispectral scanners, 1, 42; passive, 40; photography, 84; radar, 1, 40; radiometers, 40; resistivity devices, 40; scatterometers, 40; SLAR, 1; spectrometers, 40; television, 40-41, 46-47; thermal scanners, 1, 41-42; thermography, 1, 41-42
- Representative fraction (RF), 14-16
- Resistivity devices, 40
- Resolving power, 4
- Resolution: image, 4-5; limits, 16; resolving power, 4
- Root-penetration variations, 61
- Satellite, 2; imagery, 30, 47
- Scale, 14, 17, 31, 86; adjustment, 32; average photo, 14, 89; changes due to relief, 20; choice of, 4, 31; determinations, 14-16, 31, 71, 87; focal length/altitude method, 14, 15, 16; linear, 14; map distance method, 16; nominal, 14, 20; photo/ground distance method, 14-16, 15; quick laboratory check of, 16
- Scatterometers, 40
- Season of photography, 84
- Semi-controlled mosaic, 32, 58
- Semi-matte prints, 27, 28, 36
- Sensitivity, film, 5
- Sensors. *See* Specific types, such as Nonimaging sensors, passive sensors, etc.
- Sequential photography. *See* Phase photography.
- Settlement pattern analysis, 2
- Shadow, as photointerpretation factor, 8
- Shadow patterns, 53, 60, 86
- Shape, as photointerpretation factor, 8
- Sidelap, 32, 36, 70
- Side-looking airborne radar, 1
- Site detection, 59-62; crop marks, 53; plant marks, 53, 59-61; shadow patterns, 53, 61-62; soil marks, 53, 61
- Site discovery, 59
- Site identification and location, 58
- Site prediction, 62
- Site survey, field methods, 54-59
- Size, as photo interpretation factor, 8
- Soil Conservation Service, 27, 28, 65
- Soil marks, 53, 60, 84, 86
- Solar ephemeris, 86
- Sources of imagery, 27-31, 86
- Spacecraft as camera platform, 2, 53
- Spectral reflectance, 5
- Spectral sensitivity, 5
- Spectrometers, 40
- Spectrum, 5, 5, 40
- Stereograms, 13, 51; ground, 4, 13; ground coverage of, 71; vertical, 2, 3, 19
- Stereometer, 22, 36, 38
- Stereo model, 11, 38, 54, 70, 71, 72
- Stereopair, 11, 38, 54; orientation method, 11-13
- Stereoplotters, 38, 39, 54, 64, 70; C-factor, 38, 71; enlargement ratio, 70; principal distance, 71; vertical performance latitude, 71
- Stereopret, 36, 37
- Stereoscope, 11, 43, 54; lens, 11, 13; magnifying, 11; mirror or reflecting, 11, 12, 23, 38; pocket, 11, 43; zoom, 11, 12
- Stereoscopic: fusion, 19; parallax, 22, 23; perception, 50; transfer, 36
- Stereovision, 11, 49
- Surrounding objects, as photo interpretation factor, 8-9
- Synoptic overview, 53
- Taking your own photographs, 30
- Television, 40; closed-circuit analysis systems, 46-47; as an imaging sensor, 40-41
- Terrestrial photogrammetry, 69, 82
- Terrestrial photographs, 1, 2, 71, 82
- Tethered balloons, 4
- Texture, as photo interpretation factor, 9
- Thermal radiations, 41

Thermal scanning, 1, 41-42, 42  
Thermography, 1, 41-42, 42  
Three-dimensional heightening effects, 13, 19  
Tilt: axis of, 16, 18; definition, 15; displacement, 16,  
18; distortions, 16  
Tilted photograph, 1  
Time of day, 84-86  
Tone, as photo interpretation factor, 9  
Topographic maps, 31, 31, 34, 38, 58, 64, 70, 74, 75;  
digitization, 82  
Transfer: monocular, 36; stereoscopic, 36, 37  
Triangulation by radial line plot, 33, 38  
Trimetrogon, 30  
Tripods, 4, 82  
  
Uncontrolled mosaics, 2, 32  
Universal transverse Mercator projection, 33  
US Forest Service, 27, 28  
US Geological Survey, 27, 28, 30, 31, 31, 33, 38, 64,  
65  
  
Vegetative zone studies, 1, 64, 77, 79, 80, 82  
Vertical performance latitude of plotters, 71  
Vertical photographs, 1, 13, 14, 18, 30, 32, 61, 63, 64,  
71, 82, 84, 86  
Vision: binocular, 11; monocular, 9-11; stereo, 11, 49  
Volumetric analysis, 64, 70, 71  
  
Wavelength, 5  
Wedge, parallax, 22, 23, 24  
  
Zoom stereoscope, 11, 12



As the Nation's principal conservation agency, the Department of the Interior has responsibility for most of our nationally owned public lands and natural resources. This includes fostering the wisest use of our land and water resources, protecting our fish and wildlife, preserving the environmental and cultural values of our national parks and historical places, and providing for the enjoyment of life through outdoor recreation. The Department assesses our energy and mineral resources and works to assure that their development is in the best interests of all our people. The Department also has a major responsibility for American Indian reservation communities and for people who live in Island Territories under U.S. administration.







## NOTIFICATION SERVICE

Within the next five years, the National Park Service will publish several supplements to this handbook. They will include training and instrumentation supplements, a bibliography, and other publications dealing with regional applications of remote sensing for the archeologist and cultural resource manager. If you are interested in receiving notification of these publications as they become available, fill out the address form below, and mail to the Superintendent of Documents.

Please enter my name on mailing list N-557 to be notified when supplements to the Remote Sensing Handbook are available for purchase. Also, please notify me when other publications of a related nature are issued.

**Mail to me at:**

Name — First, Last	
Company Name or Additional Address Line	
Street Address	
City	State
	Zip Code
Please print or type	
(or) Country	

