

I 29.89:T 81
Tugboat Hercules, Histori...

TUGBOAT HERCULES

Historic Structure Report



San Francisco Maritime National Historical Park



Printed on Recycled Paper

TUGBOAT *HERCULES*

Historic Structure Report

1990

Prepared for
The San Francisco Maritime
National Historical Park
The National Park Service,
Fort Mason, Building 204
San Francisco, California 94123



Prepared by
Tri-Coastal Marine, Inc.
200 Burrows Street
San Francisco, California 94134



Digitized by the Internet Archive
in 2012 with funding from
LYRASIS Members and Sloan Foundation

<http://archive.org/details/tugboatherculesh00tric>

Table of Contents

Table of Contents	iii
List of Figures	v
Introduction	1
Management Synopsis	2
SECTION 1 ADMINISTRATIVE DATA	3
1-2. Administrative Data	5
1-2.1. Project Identification	5
1-2.2. Proposed Use of the Structure	5
1-2.3. Justification for Such Use	5
1-2.4. Recommendations for Preservation of the Work Products of this Study	5
SECTION 2 PHYSICAL HISTORY AND ANALYSIS	7
2-1. Cultural History	9
2-2. Chronology of Physical History	15
2-2.1. Oceangoing Tug: 1908 to 1924	17
2-2.2. Railroad Harbor Tug: 1924 - 1962	23
2-2.3. Layup and Service as Museum Vessel: 1962 to Present	31
2-3. Existing Condition	35
2-3.1. Particulars	35
2-3.2. General Arrangement	35
2-3.3. Summary of Existing Condition	36
2-4. Significance of Fabric and Features	41
2-4.1. Background	41
2-4.2. Purpose and Methodology	41
2-4.3. Rating of Elements	41
2-4.4. Form and Character	45
2-4.5. Conclusions	46
2-5. Measured Scale Drawings	47
2-6. Analysis of Treatment Alternatives	49
2-6.1. Previous Planning	49
2-6.2. Alternatives	49
2-6.3. Conclusions	51
2-7. Proposed Treatment	53
2-7.1. Overview of Treatment	53
2-7.2. Enumeration of Steps	54
2-7.3. Interpreting Hercules	73

2-6.4. Operation	75
2-8. Cost Estimates and Schedule of Implementation	77
2-8.1. Proposed Sequence of Work	77
2-8.2. Schedule and Cost by Fiscal Year	79
2-9. Impact of Proposed Treatment	81
2-9.1. Impacts	81
2-10. Recommendations for Further Study	83
2-10.1. Floodable-length Study	83
2-10.2. Historic Furnishings Report	83
2-10.3. Taking Lines of the Hull	83
2-10.4. Documentation of Machinery	83
2-10.5. Plans and Specifications	83

SECTION 3 APPENDIX **85**

3-1. Survey Findings	87
3-1.1. Hull Interior	87
3-1.2. Hull Exterior	92
3-1.3. Main Deck	93
3-1.4. Bulwarks	93
3-1.5. Superstructure	94
3-1.6. Boat Deck	100
3-1.7. Pilothouse	101
3-1.8. Stack	101
3-1.9. Main Propulsion Engine	102
3-1.10. Boiler	102
3-1.11. Auxiliary Machinery and Associated Equipment	103
3-1.12. Piping Systems	108
3-1.13. Electrical Systems	108
3-1.14. Deck Machinery and Equipment	109
3-1.15. Radio and Navigational Gear	112
3-2. Ultrasonic Survey of Hull Thickness	113
3-3. Bibliography	115
3-3.1. Physical History References	115
3-3.2. General References	115
Credits	116

List of Figures

Fig. 1. Steel Tug HERCULES at the Moore Drydock Company.	9
Fig. 2. Changes in HERCULES' configuration.	10
Fig. 3. HERCULES and her sister vessel GOLIAH.	12
Fig. 4. HERCULES towing five-masted schooner-barge W.J. PIERRIE.	13
Fig. 5. HERCULES in the colors of the Rolph Coal and Navigation Company.	14
Fig. 6. Tug HERCULES owned by Rolph Navigation & Coal Company.	15
Fig. 7. HERCULES at Moore Drydock Company pier.	16
Fig. 8. HERCULES towing car float on San Francisco Bay, 9 January 1932.	16
Fig. 9. HERCULES on dry dock following collision with steamer SAN PEDRO, 9 May 1933.	17
Fig. 10. Rudder and propeller damage resulting from collision with steamer SAN PEDRO.	18
Fig. 11. The first attempt at a doghouse.	19
Fig. 12. At dock with Western Pacific Railroad Barge No. 3.	20
Fig. 13. HERCULES towing Western Pacific Railroad Barge No. 3 in Oakland Estuary.	20
Fig. 14. HERCULES' new steel captain's cabin and wheel house under construction, Moore Drydock, October 1941.	21
Fig. 15. Boiler room of HERCULES ca. 1935-1940.	22
Fig. 16. Boiler room, ca. 1940-1961.	23
Fig. 17. HERCULES in drydock for enlargement of her rudder, Oakland, California, February 1940.	24
Fig. 18. HERCULES and HUMMACONNA at Western Pacific pier, August 1957.	25
Fig. 19. HERCULES at her berth along east side of Hyde Street Pier, ca. 1981.	27
Fig. 20. HERCULES in her temporary restoration berth at Lower Fort Mason.	29
Fig. 21. Wastage typical of that seen in local areas of HERCULES' deckhouse.	31

Fig. 22. View of the front end of HERCULES' boiler during restoration in the mid-1980s. 32

Fig. 23. HERCULES' triple-expansion engine. 36

Fig. 24. Kingpost bitt on foredeck. 37

Fig. 25. The smoke stack as viewed from aft. 38

Fig. 26. Boat Deck, looking forward from port side, 1989. 55

Fig. 27. The boiler safety valves. 58

Fig. 28. The galley, as seen from the starboard entrance. 63

Fig. 29. Proposed Modifications. 66

Fig. 30. Modifications for public access. 68

Introduction

When launched in 1907, HERCULES was among the largest and most powerful tugboats. Built for long distance offshore towing, she immediately proved her prowess by delivering herself, with her sister ship in tow, from New Jersey to San Francisco by way of the Straits of Magellan. Owned by the Shipowners and Merchants Tug Boat Company, she worked the lumber trade along the West Coast from Alaska to Central America. Her later career was spent with the Western Pacific Railroad, for whom she towed rail car barges across San Francisco Bay until her retirement in 1962.

HERCULES is one of the last remaining examples of a type of vessel that has played a vital role in the development of the American West Coast. Her history is integral with that of San Francisco, where she has been a significant actor in commerce and industry for more than eighty years.

HERCULES was acquired by the National Park Service in 1977, along with the rest of the State Historic Park fleet. Since that time, she has been visible to the public, but has not been restored or made accessible to visitors. A significant amount of restoration has been undertaken by volunteers, but her full restoration, interpretation, and operation remain unrealized potentials.

The Historic Structure Report offers a proposed treatment that will achieve these potentials, while ensuring long-term preservation. In addition, the Report provides documentation of HERCULES through measured scale drawings, and a physical history that chronicles the physical changes the vessel has undergone. A baseline for treatment is provided by a survey of existing condition.

It is hoped that the Report will serve as a resource for those engaged in HERCULES' restoration, as well as a guiding document for the preservation and interpretation of this valuable cultural resource.

Management Synopsis

The steam tug HERCULES, a National Historic Landmark vessel, is part of the fleet of historic ships of the San Francisco Maritime National Historical Park. She is locally, regionally, and nationally significant, and is the only intact example of an oceangoing steam tug remaining in the United States.

To date, HERCULES has received little preservation funding and has not yet been adequately stabilized. At present, she continues to deteriorate, with resultant loss of historic fabric.

The alternatives for treatment range from stabilization to adaptive use, and are assessed based on the degree to which they protect, preserve, and interpret the resource:

- Stabilization is considered the minimum requirement for preservation, but would not provide adequate interpretation of the vessel.
- Restoration for use as an excursion vessel is not recommended, as the necessary alterations would result in major impact to historic integrity.
- Restoration as a floating exhibit is recommended. This treatment will allow public access and interpretation without undue impact to historic integrity. A degree of operational capability is proposed as a means of enhancing interpretation and generating volunteer interest that will in turn benefit the preservation and maintenance of the vessel.

A four-phase program is recommended for implementation of the proposed treatment. The schedule of implementation would place the highest priority on preservation measures, followed by public access and interpretation. The cost breakdown would be as follows:

Phase I	\$495,750
Phase II	214,000
Phase III	176,300
Phase IV	260,000
Total Cost for Four-phase Project	\$1,146,050

The first phase of implementation includes a major drydocking period to address deterioration resulting from years of deferred maintenance. This will result in a significant front-end loading of program cost. After completion of Phase III, the primary preservation requirements will have been achieved. The remaining restoration work could therefore be completed over an extended period without risking further deterioration of the resource.



SECTION 1 ADMINISTRATIVE DATA

1-2. Administrative Data

1-2.1. Project Identification

The steam tug HERCULES, part of the collection of San Francisco Maritime NHP, is docked at Pier 1, Fort Mason Center. Fort Mason Center is owned by the National Park Service, and administered by Golden Gate National Recreation Area. Cooperative agreements between Fort Mason Center and Golden Gate National Recreation Area provide San Francisco Maritime National Historical Park with a rent-free slip.

The HERCULES is identified as a primary resource of the park in the San Francisco Maritime National Historical Park Act of 1989, Public Law 100-348, June 27, 1988.

The HERCULES is No. SS-05 on the National Park Service List of Classified Structures (LCS), and was placed on the National Register of Historic Places in 1975. HERCULES was declared a National Historic Landmark in 1986.

1-2.2. Proposed Use of the Structure

The HERCULES is listed on the LCS in the Management Category A: Must be Preserved. Currently, the vessel provides only limited access to the public. The proposed treatment of this historic ship is preservation/interpretation. Successful implementation of this treatment plan—in a series of orderly phases—will ensure long-term preservation, restore limited operation, and provide an unparalleled interpretive resource.

1-2.3. Justification for Such Use

Preservation and interpretation of the HERCULES is in keeping with NPS policies and guidelines, and is consistent with the goals of the San Francisco Maritime National Historical Park. The Golden Gate National Recreation Area General Management Plan, and the Golden Gate National Recreation Area National Maritime Museum draft Interpretive Prospectus, both support preservation and increased interpretation of the HERCULES.

1-2.4. Recommendations for the Preservation of Work Products

All objects, documents, records, photographs, negatives and files collected or produced as a result of this study must become part of the park's museum collection to be preserved, managed, and stored in the Division of Collections Management, San Francisco Maritime National Historical Park, at the conclusion of this study.



SECTION 2 PHYSICAL HISTORY AND ANALYSIS

2-1. Cultural History

The HERCULES is a large, steel-hull, single-screw, steam tugboat built for long hauls in the open ocean. She is a rare surviving link with the era of steam power, and represents the finest of American maritime industrial technology as found in the first decade of the twentieth century.

There are now no oceangoing steam tugs still active in the United States, and fewer than ten steam tugs of any type preserved in museums and shipyards across the country. HERCULES is outstanding, even among this select company, because she retains her historical and structural integrity as an example of broad nationwide patterns of U.S. maritime history.

Around the turn of the twentieth century, San Francisco was a great center of international commerce and trade, and the busiest Pacific port of the United States. Steamers carried passengers and cargo from the far corners of the world into San Francisco's Bay, while windjammers by the score still plowed their stately way through the swells.

Competition was fierce to tow sailing ships into and out of the bay. There were two major competitors in the towboat business in San Francisco at the time: the "Blackstack" tugs of Spreckels Towboat Company; and the "Redstack" tugs of Shipowners' and Merchants' Towboat Company.

In 1900, Shipowners' and Merchants' embarked on a program of new building to replace its aging fleet. Five wooden-hulled boats were ordered from local builders. In 1907, the company sent its superintendent, Captain William J. Gray, one of the outstanding towboat pioneers of the Pacific Coast, to Camden, New Jersey. Gray was to supervise the construction of two powerful new oceangoing tugboats contracted to be built at the yards of John H. Dialogue & Son.

Dialogue had previously built one boat for Shipowners', the iron-hulled SEA LION of 1884. Dialogue's business on the Delaware River dates back to 1858. This East Coast yard was selected because of its reputation of turning out high quality tugboats. In 1882, it was reported that, "This yard has been established for many years and has had its ups and downs; but it has now proved the superior excellence of iron hulls for tugs, and builds four or five of that class of boat every year..." Of special

note is the fact that the frigate U.S.S. CONSTITUTION was reconstructed there in 1876.

The story is told that:

Captain Gray got to worrying about HERCULES and her sister, the GOLIAH, during their building. He went back to Dialogue's yard and had another look at them in the sleet and snow of wintertime. HERCULES had been framed and plated, but the GOLIAH was still in frame.

He said later that he stood looking at them and then went into the office. He said to Dialogue: "You know a vessel looks different in the drawings and the model than when you see the real thing starting to take shape. These tugs are a little too narrow and too deep. I am going to be losing men off them when a sea comes aboard."

The old formula was half the beam to the length. The reason for building a deep hull was so that she didn't throw her wheel (propeller) out and also to get enough room for coal and water. The bug-a-boo of tugboatmen was what we called cavitation—getting air to the wheel in heavy weather on a lee shore. A good pulling heavy weather tugboat is apt to be a bit wet.

Well, Dialogue apparently agreed and they talked it over. The builder said that he couldn't do anything about the HERCULES because she was already plated, but he could widen the GOLIAH a bit by heating up the frames and bending them out. "That way it will give you a foot more beam at the deck, and a foot more molded depth amidships."

Captain Gray said afterward that the HERCULES was hard on men, but she was always pulling. He often said that the positions of the two tugs on the Pacific Coast should have been reversed—that the GOLIAH should have been stationed in San Francisco for sailing ship work, short hauls, and the HERCULES up on the (Puget) Sound for the longer hauls, worse weather, and log raft work. (1)

HERCULES and GOLIAH were fitted out and readied for sea at the beginning of 1908. Since they were built so close to the great Appalachian coalfields, it was considered unusual that the sisters were oil burners. However, they were intended for West Coast service and reflected western conditions. Coal was not nearly as

abundant as in the east, and oil was the fuel of the future on the Pacific shore (and ultimately elsewhere).

HERCULES' maiden voyage was extraordinary. She towed her sister nonstop 14,000 miles, all the way around South America to San Francisco. Their route was through the Straits of Magellan. Each vessel was topped off with 105,000 gallons of oil. The GOLIAH acted in the role of tanker for her sister.

In a harkening back to the earliest days of steam navigation, sails were rigged on fore and after masts of each vessel to take advantage of favorable winds. As near as can be determined, this was the longest non-stop tow in history at the time, and occasioned much comment in nautical circles.

The HERCULES was commanded by Dan Thomsen, a colorful captain, and highly regarded on the West Coast. The weather was so rough as they set out that the pilot was unable to get aboard, and they were forced to lay over one day in the lee of the Delaware breakwater. Captain Thomsen recalled that:

"Two spells of foul weather hit us coming out. Crossing the Gulf shortly after leaving Delaware breakwater we ran into a heavy gale, and we had all we could do to keep the craft free. For eight days the storm lasted, but when it abated we had fair weather until we emerged from the Straits of Magellan on March 12.

"It shut in thick with hail and rain squalls. The HERCULES stood up on end at times, and had it not been for the automatic towing machines on the whipping hawser we would have parted. Some of the hands thought we never would weather it. (2)

But weather it they did—completing a non-stop tow of 13,460 miles in 68 1/2 days. The two tugs arrived in San Francisco and dropped anchor off Fisherman's Wharf on April 11, 1908. After a short trip to the drydock, and HERCULES began an eventful career in oceangoing towing.

Throughout the oceangoing portion of her career the HERCULES generally carried a crew of three firemen, three oilers, a chief and two assistant engineers, three deckhands, a cook, two mates, and a captain—enough manpower to work three shifts while at sea, four hours on and eight off.

Life on an oceangoing tug could be quite uncomfortable. The deep, narrow hull rode so low in the water that the main deck was likely to be awash much of the

time. There were, however, many offsetting advantages to the trade.

Tugboat captains, for instance, were generally well-known, highly respected, and well paid. It took considerable experience and judgement to operate both the tug and its powerful towing equipment to safely pull heavy loads through heavy seas in bad weather. And West Coast ports were characterized by shallow bars and narrow entrances. (3)

Along the Pacific Coast, where the prevailing winds blow from the northwest, it was common for sailing ships with a charter deadline to hire a tug to tow them up the coast. Log rafts, barges and an occasional disabled steamer were the mainstays of the southbound business. During the period from 1908 to 1924, HERCULES came into contact with the widest spectrum imaginable of Pacific Coast maritime trade.

In 1908, she towed the disabled steam schooner ABERDEEN from Eureka to San Francisco. ABERDEEN is notable because she was later wrecked off the Golden Gate in 1916. Another wrecked steam schooner, SANTA CLARA, made the same tow behind HERCULES entirely waterlogged and awash. (4)

In 1912, HERCULES towed a caisson, for the first drydock at Pearl Harbor, from San Francisco to Hawaii. She made several subsequent voyages to the Hawaiian Islands.

During the construction of the Panama Canal, HERCULES towed a caisson for the Miraflores Locks to Balboa from San Francisco's Union Iron Works. Upon completion of the canal, HERCULES took advantage of the shortcut in her first coast-to-coast trip since her maiden voyage. She hauled the dredge SAN DIEGO to Jacksonville, Florida, from San Pedro, California, in 27 days—approximately one-third of the time of her first voyage.

Lumber was the premier coastal cargo of the Pacific Coast. Sailing lumber schooners had been carrying timber cargo southward to the burgeoning cities since the 1850s. In 1895, the first successful attempt was made to tow logs down the coast, chained together in huge rafts. Seven million board feet could be delivered—a dozen times the load of an average schooner. But it was slow and disagreeable work. HERCULES' 1913 log raft tow from Astoria, Oregon, to San Diego took 29 days—longer than the voyage to Florida via the new canal. A mate on another tug summed up his feelings about the business:

"You turn in at night, und dere iss a lighthouse outside your cabin vindow. In de morning you gets up—and dere, py Yesus iss de same damn lighthouse! You stand und talk mit somebody until you get sick of him, so you valk away. You go around de deckhouse—and you run right into him head-on. Dese tugs iss so little you can't get away from nobotty!" (5)

HERCULES made at least six more log raft tows. However, the feelings of her crew were not necessarily in agreement with the just-quoted mate. One of HERCULES' firemen recalled such a voyage more fondly:

"Out through the Golden Gate, the most beautiful harbor in the world. North, towing this barkentine to Port Washington in Canada. Thence south, empty to Astoria where we picked up six million feet of timber in a raft to tow south to San Diego. Long, slow lazy days, making no more than three knots, even the patent log would not work. We rigged a fishing line on it and caught beautiful king salmon on the way.

Catch one at 11 o'clock, off with head and tail, clean and slice into steaks. Ready to eat at 11:30 and go on watch with full belly. The rest of us eat at 12 noon but there was always plenty of salmon. We had no refrigerator, just a cooler on top deck and the meat got pretty raunchy after a couple of weeks, so lovely salmon was a Godsend.

"The weather off the coast of Oregon in summer can get rough. We had extra planks in our bunks, hands against bulkheads, backside to the plank, knees drawn up and try to sleep without falling out.

"All good things come to an end however and eventually we arrived in San Diego. Quite a tricky channel there, but we made it and hit for home empty. Arrived in "Frisco" as the sailormen called it, we staggered ashore trying to find our land legs. The nearest speak-easy helped a lot and soon we were ready to ship out again." (6)

The year 1916 was a significant one for HERCULES. While up in Seattle, Washington, it was noted in the press that:

"The Hyde Automatic Brake, a device for bringing vessels to a sudden stop, was tried on the tug HERCULES in the harbor yesterday. The tug was crossing the bay at an 8-knot clip when J.H. Hyde of Tacoma, the inventor of the brake, gave the signal ... a number of other mariners who were aboard as Hyde's guests, forgot to hold on to something solid. The tug came to a dead stop in 10 feet, sending Lounsberry sprawling over the deck, while several of the other mariners capsized completely. The brake

consists of steel plates attached to the bottom of the hull of the ship in such a way that they can be opened outward." (7)

Perhaps this device worked too well, for it was never mentioned on HERCULES again, and certainly never became a common feature of vessels on this or any other coast.

Later that same year, HERCULES towed the schooners ESPADA and C.A. THAYER from San Francisco to Port Townsend, Washington. This routine towing job is now significant because the C.A. THAYER survived wear and time to be preserved alongside HERCULES as a National Historic Landmark.

HERCULES also towed Hawaii's museum ship FALLS OF CLYDE to the San Francisco Bay port of Oleum to load a cargo of crude. HERCULES, however, was not in her element docking a ship—she was a deep-water tug. It is said that the FALLS' jibboom raked over the wharf and bent the dolphin striker, knocking off its tip.

In 1918, the Shipowners' and Merchants' Redstack fleet was acquired by a syndicate headed by Thomas Crowley. Crowley was a former whitehall boatman who had moved into gasoline-powered launches and tugs. He had tried to enter the steam tug business in 1912, but had been squeezed out by Redstack. His takeover of Shipowners' and Merchants' was accomplished with a somewhat vengeful aura. Crowley's maritime enterprises have since grown to worldwide significance in the tug-boat, barge, launch and harbor cruise fields.

Not long after the takeover, HERCULES was sold to the colorful Mayor of San Francisco, and future Governor of the State of California, James "Sunny Jim" Rolph, Jr. Rolph was a major San Francisco sailing ship owner. In 1918, he told his son that "As long as the wind blows, there will always be sailing ships!"

It has been said that he was always a shipowner first and Mayor second. In 1917, just after the United States' entry into World War I, he entered the shipbuilding business by purchasing the venerable Fairhaven, California, yard of Hans Bendixsen and prospered mightily in those boom times.

Rolph was an original member of Crowley's syndicate, and the value of his shares in Redstack was apparently part of the deal to purchase the HERCULES. His Rolph Navigation and Coal Company took over HERCULES, changed her plain red stack to black with a

big white "R," but otherwise operated her in much the same service as before. During her tenure for Rolph, she made a particularly noteworthy voyage when:

The Rolph tug HERCULES has just completed a record, long-distance tow. This was the British motorship LAUREL WHALEN which the HERCULES towed from Papeete, Tahiti Islands ... The tug HERCULES left San Francisco and, arriving at Papeete, started with the crippled motorship for Vancouver on March 3 of this year. With her tow, the HERCULES put in to Honolulu on March 21 for fuel, departing the following day. (8)

Not long after, HERCULES went to Mare Island Naval Shipyard in Vallejo, California, to tow the newly launched battleship U.S.S. CALIFORNIA to Hunter's Point Naval Shipyard in San Francisco for further fitting out. A short tow, but significant because of the CALIFORNIA's role in U.S. naval history. On December 7, 1941, she was hit and sank to the bottom of Pearl Harbor during the surprise air raid that propelled the U.S. into World War II.

Between about 1920 and 1922, the HERCULES was operated as part of a new Blackstack Line, a company formed to oppose the Crowley/Shipowners' and Merchants' monopoly of San Francisco steam tug operations. The principals included William Gray and Clem Randall, both former Shipowners' officers fired when Crowley took over; Henry Peterson, a long-time rival of Crowley in the gas tug and launch business; and James Rolph. Rolph Coal and Navigation retained formal ownership of the HERCULES throughout this period. The effort failed due to the collapse of the shipping market during the post-war slump and to the Redstacks entrenched position in the local tug industry.

In 1923, HERCULES passed briefly through the hands of Moore Drydock Company. The head of the drydock company was a brother-in-law of Rolph and had lent him money for the purchase of the HERCULES. When Rolph fell on hard times during the post-World War I shipping bust, Moore apparently foreclosed on his loan and took over the HERCULES.

In 1924, she was sold to the Western Pacific Railroad Co. for \$62,500. Her career changed significantly at this time, for she no longer served as a deepwater towboat. Entries in her logbooks document her workaday life from the 1920s through the 1950s as she shuttled railroad car barges back and forth across San Francisco Bay between terminals in Alameda, Oakland and San Francisco's northern waterfront.

In 1941, her foremast was removed and the wheelhouse raised in order to improve visibility over the railroad car barges. HERCULES now operated around the clock, using two, twelve-hour watches daily, and changing crews early in the evening and morning. A schedule of three, eight-hour watches was instituted just before World War II.

By the late 1940s, HERCULES worked only one or two eight-hour shifts per day. Towards the end of her career, as railroad traffic declined, she was often laid up for days at a time. (9)

In 1962, she was retired by Western Pacific—a victim of changing nationwide trends in rail transportation, and of the introduction of the diesel-powered, self-propelled car float LAS PLUMAS. She changed hands again, passing to Oakland tugboat operator John Seaborn, who kept her from the scrapyards. She was, however, threatened with conversion to diesel power when a spirited fundraising drive led to her acquisition by the California State Park Foundation for the San Francisco Maritime State Historic Park.

Now a part of the San Francisco Maritime National Historical Park, HERCULES is a floating demonstration of significant, broad and changing patterns in United States maritime history during the first half of the twentieth century. Her association with noteworthy vessels, shipowners, industries and patterns of trade, combined with her excellent physical integrity, make her worthy of the status: National Historic Landmark.

Excerpted with permission from an article by Stephen Haller, which first appeared in Sea Letter, the National Maritime Museum Association's maritime history journal.

NOTES

1. Transcript of conversation between Karl Kortum, Chief Curator of the National Maritime Museum, and Jim Cary, son of George Cary of Cary-Davies Towboats; 3/19/1965; on file at the National Maritime Museum, San Francisco.
2. As quoted in *Pacific Motor Boat*, December 1950, p. 15 "In Those Days There Were Sixteen Men in the Foc'sle" by Albert Y. Websthoff.
3. *San Francisco Historic Ships*, NPS, p. 41.
4. *Humboldt Standard* of April 4, 1910; compiled by Wallace C. Martin for publication in *Sail and Steam on the Northern California Coast, 1900 - 1950*, National Maritime Museum.
5. *Ships of the Redwood Coast*, J. McNairn and J. MacMillan, Stanford University Press, p. 118.
6. Interview with Albert J. Hooy by Stephen W. Hastings of the National Maritime Museum, San Francisco. Transcript on file at the J. Porter Shaw Library.
7. *Humboldt Standard*; February 22, 1916; cited by Martin; op. cit.
8. *Humboldt Standard*; April 14, 1920; cited by Martin; op. cit.
9. Catalog File GOGA 11805-20; of August 2, 1983; by H. Leigh Newcomb, on file at National Maritime Museum, San Francisco.

BIBLIOGRAPHY

- McNairn, J. and MacMullen, J. *Ships of the Redwood Coast*. Stanford, CA: Stanford University Press.
- Newell, G. and Williamson, J. *Pacific Tugboats*. Seattle, WA: Superior Publishing Co., 1957.
- Files of the National Maritime Museum, San Francisco' specifically: Transcripts of Interviews, Catalog files, San Francisco Marine Exchange Index Cards.
- Personal Conversations with: Karl Kortum, Chief Curator, National Maritime Museum, San Francisco; Christopher Hoskins, Tugboat Restoration Volunteer, National Park Service; Charles Hopkins, Tugboat Restoration Volunteer, National Park Service; H. Leigh Newcomb, Museum Technician, National Maritime Museum, San Francisco; Theodore Miles, Assistant to the Curator, National Maritime Museum, San Francisco.

2-2. Chronology of Physical History

HERCULES' history may be divided into three periods:
1908—1924

Period in service as a long-distance deep-sea tow-boat, transporting sailing vessels, barges, "log rafts," and heavy equipment coastwise and to distant destinations such as Panama, Florida, and across the Pacific. She also served in this period as a harbor tug for oceangoing vessels entering and leaving port, and occasionally towed car floats across the bay. From 1907 to 1918 she was owned by Shipowners' & Merchants' Tug Boat Company who had commissioned her building. After 1918 ownership went to the Rolph Coal & Navigation Company.

1924—1962

Period in service towing "car floats"—barges equipped with railroad tracks for transport of railroad cars—across San Francisco Bay. Owned by the Western Pacific Railroad Company.

1962—Present

Period of lay-up under various ownership, and as a museum vessel (though never opened to the public) under state and federal ownership.

Other than the progressive change in the configuration of her pilot house, HERCULES has undergone relatively little structural alteration since her construction in 1907. Several minor changes took place, including the

removal of her foremast and the replacement of her wood mainmast with a steel one, the addition and subsequent removal of wireless shackles forward of the mainmast, and the removal of her donkey boiler. In addition, her bow chocks were modified, a heavy steel guard (rub rail) was added on her starboard side, and her rudder was enlarged (see Figure 2). Her paint scheme on deckhouse, pilot house and stack was changed along with changes of ownership.

Documentation of the vessel's cultural history exists in the form of logs, press notices, and oral histories. For the period of ownership by the Western Pacific Railroad Company, some business records are preserved by the San Francisco Maritime National Historical Park (SFMNHP). Photographs in the collection of the SFMNHP are the principal documentation of HERCULES' physical changes. Some of these are precisely dated and highly reliable while others lack accurate dating. Unless otherwise noted, photographs cited from SFMNHP archives are identified by catalogue number.

As a working vessel, and subsequently a museum ship, HERCULES' history has been a constant process of renewal, repair, and replacement of worn or failed parts. These activities fall under the category of ship maintenance and are not considered significant to the physical history. The following is a chronology of changes in her fabric or configuration over the three periods of her life.

Fig. 1. Steel Tug HERCULES at the Moore Drydock Company, Oakland, California. December 20, 1923.

SFMNHP B4.8,262n1



CHANGES IN CONFIGURATION

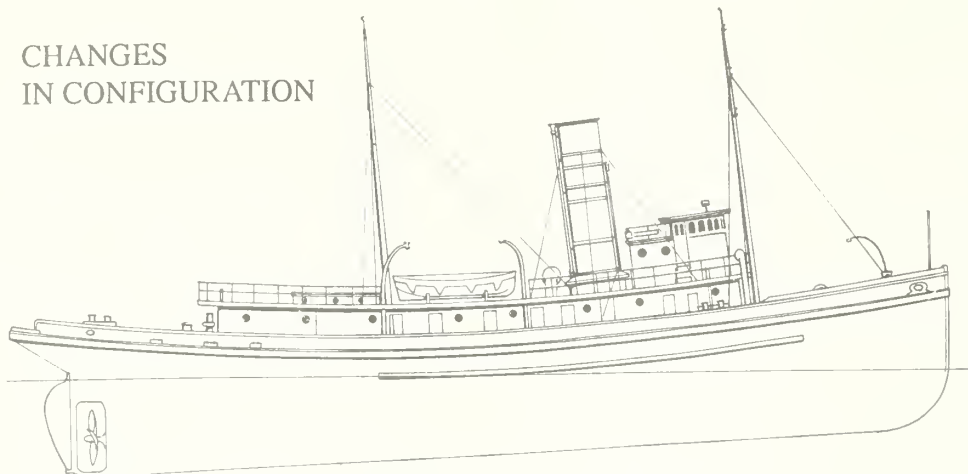

A. In Service to Red Stack, 1908-1918

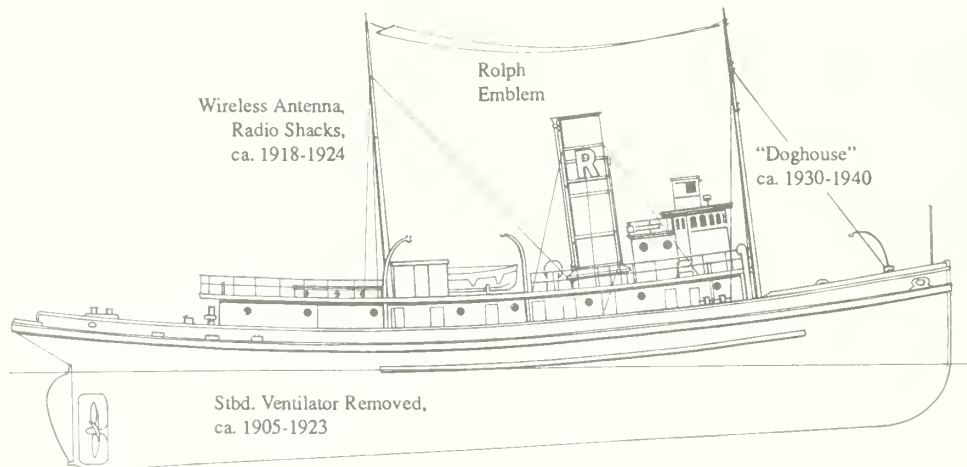

Wireless Antenna,
Radio Shacks,
ca. 1918-1924

Rolph
Emblem

"Doghouse"
ca. 1930-1940

Subd. Ventilator Removed,
ca. 1905-1923

B. Changes 1918-1940

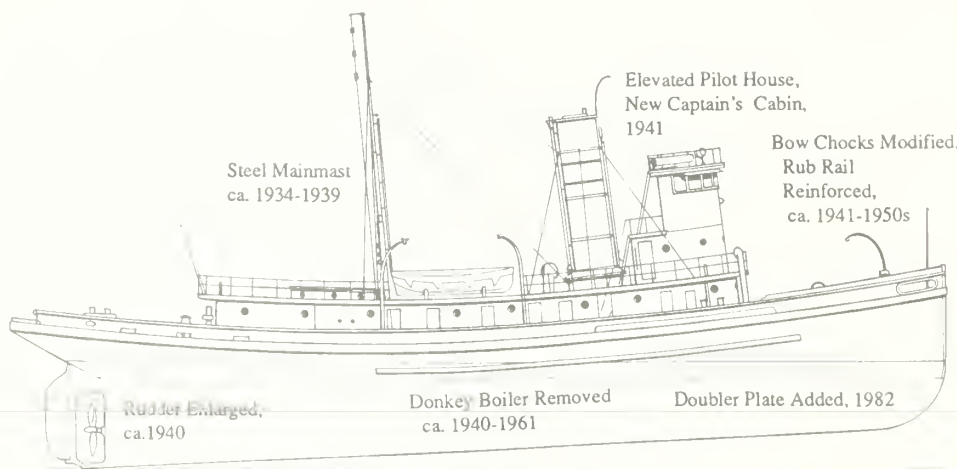

Steel Mainmast
ca. 1934-1939

Elevated Pilot House,
New Captain's Cabin,
1941

Bow Chocks Modified,
Rub Rail
Reinforced,
ca. 1941-1950s

Rudder Enlarged,
ca. 1940

Donkey Boiler Removed
ca. 1940-1961

Doubler Plate Added, 1982

C. In Service with W.P.R.R., 1924-1962

Fig. 2. Changes in HERCULES' configuration.

Graphics: David Canright

2-2.1. Oceangoing Tug: 1908 to 1924

1907
Construction

Steam tug HERCULES and her sister vessel GOLIAH were built in Camden, New Jersey, at the shipyard of John H. Dialogue & Son, to the order of the Shipowners & Merchants Tug Boat Company ("Red Stack") of San Francisco.

"The HERCULES and the GOLIAH are of the following general dimensions:

Length between perpendiculars	140 ft
Length overall	150 ft.
Beam	27 ft.
Depth of hold	17 ft.
Gross tonnage	414 tons
Net tonnage	221 tons

"They are constructed of steel throughout, with complete steel deck, steel bulkheads for oil tanks (with necessary subdivisions), high coamings, and steel deck houses. Both boats have, in addition to the transverse oil-tight bulkheads, longitudinal bulkheads to prevent the movement of the oil, the stern as well as both the forward and after bitts being especially constructed for this particular service. They are fitted with a complete railing around the upper deck as well as around the roof of the pilot house. The deck house is arranged so that it will be possible to go from one end of the boat to the other without going outside. The crew's accommodations are, as usual, located in the forecabin, with a special dining room for their use, the senior officers being located in the forward end of the deck house, and the junior officers housed just behind the fire room.

"As the tugs will use oil for fuel on the Pacific Coast, they have been fitted in the East to use this kind of fuel instead of coal, so that on their arrival at San Francisco it will not be necessary to make any changes in their arrangements, and they may be put to work at once. They have a tank capacity of about 105,000 gallons of fuel each, which will give them a cruising radius of not less than 8,000 miles apiece.

"The engines are of the usual vertical, inverted, direct acting triple-expansion type, having cylinders 17 in., 24 in., and 41 in., by 30 in. stroke, constructed for a working pressure of 180 pounds. The air and bilge pumps are connected to the main engine, and the circulating, donkey, fire, and sanitary pumps are independent.

"All stuffing boxes are fitted with metallic packing. There is a special pump for circulating water in the boilers while getting steam. Two oil pumps with heaters are also provided for supplying air for combustion. Steam towing engines suitable for taking care of 1-3/4 in. diameter of wire hawser have been fitted. There is also a complete electric light installation, including searchlight, of 7 1/2 K.W., made by General Electric Company, all wires being run in iron pipe. Steam steering engine of the Williamson Bros. Co. type has been fitted. Steam windlass, suitable for 5/8-in. chain, made by the Hyde Windlass Company, of Bath, Maine, is included. Steam capstans have been supplied by the builders of the vessels, everything in them being of the latest improved type and thoroughly modern throughout.

"The boilers are of the Scotch type, 15 ft. diameter by 12 ft. long, each having four furnaces, and constructed for a working pressure 180 lbs. The furnaces are of the "Fox" type and are arranged for burning oil as fuel.

"Each boat is provided with a steel hawser 200 fathoms long. In addition, one of the boats is provided with a manila hawser 200 fathoms long. Both boats are likewise provided with a donkey boiler arranged for burning coal or oil as fuel, as may be required" (*Nautical Gazette* 1908).

The GOLIAH is reported to have had one foot greater beam than HERCULES, the result of Capt. William J. Gray, Senior, construction supervisor from Red Stack, deciding while the GOLIAH was still in frame that they were too narrow: "I am going to be losing men off them when a sea comes aboard." The HERCULES was already plated and could not be altered, but the GOLIAH's frames were heated and bent outward, giving her more beam at the deck and a foot less molded depth amidships (Carey 1965).

Source: *Nautical Gazette*, 6 February 1908. "Two New Dialogue-Built Tugs for Service on the West Coast," as transcribed for Harry Dring. Written for a trade publication, this contemporary report may be considered quite reliable.

Carey, J. 6 March 1986. Transcript of conversation with Karl Kortum. Carey's father was a San Francisco tugboatman and heard the story firsthand from Capt. Gray. Though a third-hand account, some credence may be given to this story, and the difference in dimensions is corroborated in an article by Albert T. Westhoff in *Pacific Motorboat*, December 1950.

Fig. 3. HERCULES and her sister vessel GOLIAH (obscured by large sheerlegs behind aft end of HERCULES' deckhouse) at their builder's yard in 1907. Square yards and staysails are rigged for the long voyage to the West Coast.

Photo: SFMNH 11.7910n



1908, 24 January — 12 April
Delivery

"Two vessels left the Delaware River last week on what promises to be a memorable as well as record-breaking voyage. They were the new seagoing tugboats HERCULES and GOLIAH, built at the shipyard of John. H. Dialogue & Son, ship and engine builders, Camden, N.J., for the Shipowners and Merchants' Tugboat Co., (sic) of San Francisco. They are bound for San Francisco, via the Straits of Magellan

"Our illustration shows the HERCULES as she appeared a few days before leaving the shipyard. The GOLIAH lies under the shears at the end of the pier. As will be noticed the tugs have two masts, the foremast being placed just forward of the main deck house, and the main mast about equidistant between the smokestack and after end of the deck house. During the voyage a large square sail on the foremast may be used on both boats for raising in order to take advantage of any favorable wind" (*Nautical Gazette* 1908). Capt. Thomsen mentions the use of this sail, and of "fore and aft sails" in his log of this voyage (Thompson 1908).

Source: *Nautical Gazette*. 1908.

Capt. Thomsen. 1908. Log of the tug HERCULES. Copy of manuscript in Documents Collection of the SFMNH.

1907—1918
Shipowners & Merchants Tug
Boat Company ("Red Stack")

Photographs from this period show HERCULES unchanged but for the absence of the square yard on the foremast mentioned on her departure from Camden. Her duties included towing vessels in and out of San Francisco Bay, and making many offshore tows up and down the coast, to Panama, and around the Pacific.

Fig. 4. HERCULES towing five-masted schooner-barge W.J. PIERRIE, ca. 1910.

Photo: SFMNH/J5.28,407n1





Fig. 5. HERCULES in the colors of the Rolph Coal and Navigation Company; black stack with large white "R." Note wireless shacks at mainmast, and antenna wires between masts.

Photo: SFMNHP A1.8415n

Some recorded examples of her work are as follows:

- 1915, 7 July-3 September: Towed log raft, Astoria, Oregon to San Diego, California.
- 1916, 20 April-10 May: Towed caissons from San Francisco to Honolulu for construction of U.S. Drydock at Pearl Harbor.
- 1916, 4-14 September: Towed schooners C.A.THAYER and ESPADA, San Francisco to Port Townsend.

Source: S.F. Marine Exchange Index Cards.

1918
Change in Ownership

In 1918, the Shipowners & Merchants Tug Boat Company was bought out by Thomas Crowley's Launch and Tugboat Company, the combined fleets retaining the name "Red Stack." (Lindley, et al 1927). Crowley, less interested in the deep-sea and coastal business than the harbor towing services, sold the HERCULES in April of that year to James Rolph's Rolph Navigation & Coal Company of San Francisco ("Black Stack"), for \$350,000.

Source: *Humboldt Standard*, 25 April 1918. Article transcribed by Wallace E. Martin in his book *Sail & Steam, 1900-1950*. 1984. Reliable.

Lindley, W. P., with Gray, W. J., and Harvey, G.H. January 1927. *Red Stack, Black Stack, and Griff's Pacific Marine Review*. A highly reliable, firsthand account of San Francisco tugboat history.

Ca. 1918
Modifications and Additions

With her change of ownership, HERCULES' smokestack was painted black with the large white "R" emblem of the Rolph Coal & Navigation Co. During this period she was also fitted with wireless equipment. Two small shacks were mounted just forward of the main mast on the deckhouse and antenna wires rigged between the fore and main masts. The forward shack housed the batteries and the after shack the transmitter and wireless operator. This separation was necessary due to the dangerous fumes produced by the batteries (Hoskins 1989). Source: Undated photograph (SFMNHP Photo No. AI.8415n) showing wireless gear. Rolph Company "R" emblem seen on stack dates photograph to ca. 1918. Reliable as to identification of vessel and configuration while under Rolph ownership (1918-1921).

Moore Drydock Company. 20 December 1923. Photographs (SFMNHP No. B4.826n1 and P81-005a) show vessel alongside pier, with wireless gear and radio shack in place, lacking the "R" emblem on stack. Reliable as to date, identity of vessel, and specific alterations noted.

Hoskins, C. 1989. Research notes by longtime HERCULES volunteer with knowledge of period radio equipment. Reliable.

1919
Repair

Boiler disassembled for major repairs.

Source: Moore Drydock Company. 2 October 1919. Photograph (SFMNHP Photo No. P81-005.316a) showing lower front head of boiler removed. Highly reliable as to subject and date.

Fig. 6. "Tug HERCULES owned by Rolph Navigation & Coal Company. Showing lower front head removed from boiler. Repairs being made by the Moore Shipbuilding Company. Oakland. Cal. Oct. 2, 1919." (Photo Caption)

Photo: SFMNHP P81.005.316a

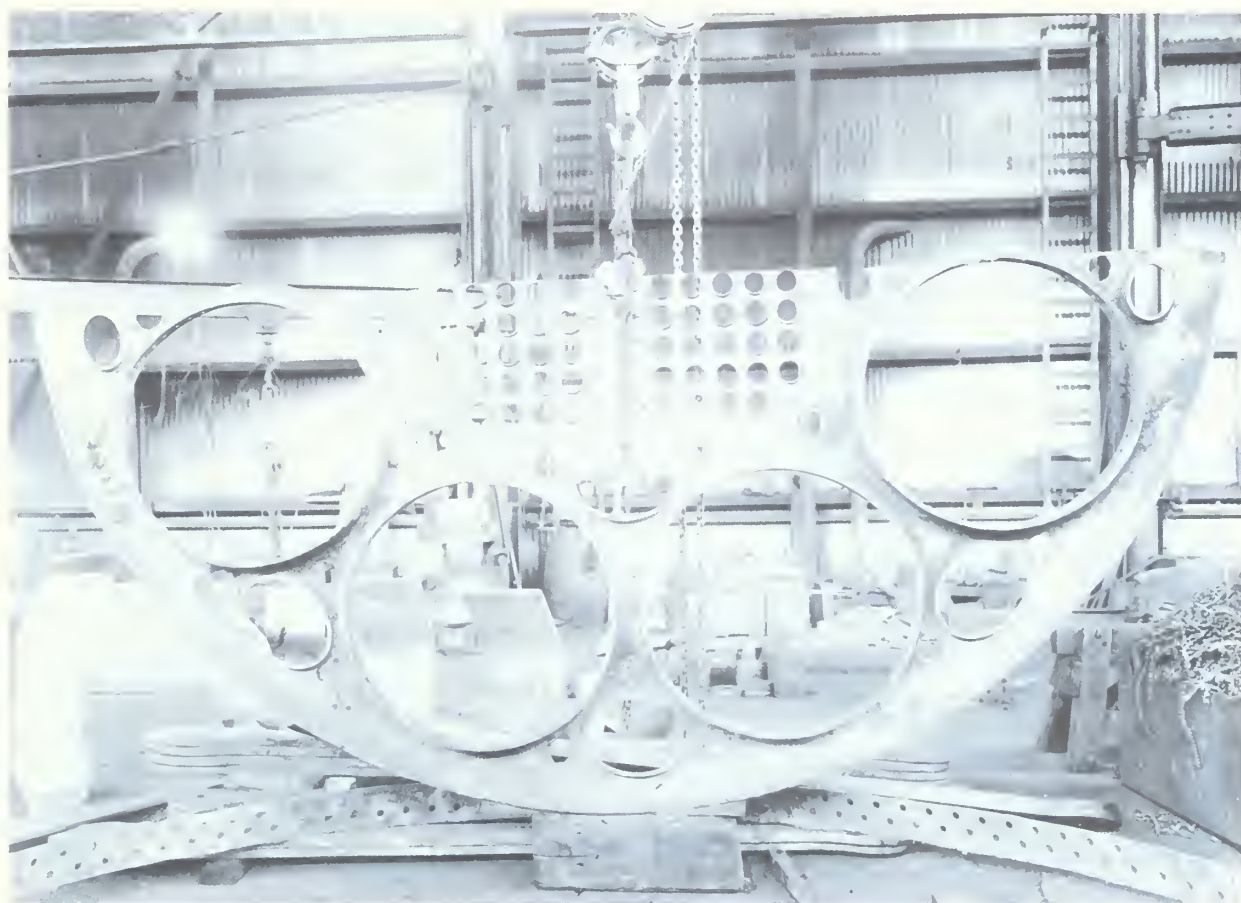

Fig. 7. HERCULES at Moore Drydock Company pier during brief period of ownership by the company, 1923. Photo: SFMNHP B4.8253



1921
Change of Ownership

The post-World War I depression hit James Rolph particularly hard, and in 1921 he dissolved most of his maritime interests (Lyman 1949). Ownership of the HERCULES apparently came at this time to the Moore Drydock Company of Oakland, California which had done most of her repair work and continued to do so for years afterward.

Source: Lyman, J. 1949. *Log Chips* (transcription by Karl Kortum). Highly reliable.

Fig. 8. HERCULES towing car float on San Francisco Bay, 9 January 1932. Western Pacific Railroad emblem is seen on stack. Foremast and wireless shacks have been removed, pilot house has not yet been altered.

Photo: John W. Proctor. SFMNHP B5.21,068n



2-2.2. Railroad Harbor Tug: 1924 to 1962

1924, 28 April
Change of Ownership

In April of 1924, HERCULES was sold by Moore Drydock Company to Western Pacific Railroad Company for \$62,500.

Source: Copy of Western Pacific Railroad Bill for Voucher. Reliable.

1924
Alteration

The four original oil burners on the boiler are replaced with four burners manufactured by the Coen Company.

Source: Voorheis, T. 1989. Interview of Temple Voorheis, president of the Coen Company, by Don Birkholz. Reliable as to subject and date.

Ca. 1924
Alteration

When purchased by Western Pacific Railroad Company, HERCULES' stack was given the emblem of the line on a square signboard.

Source: Proctor, J.W. 9 January 1932 (SFMNHP Photo No. B5.21,068n). One of numerous photos of HERCULES in that service. Exact date of application of emblem is not certain.



Fig. 9. HERCULES on dry dock following collision with steamer SAN PEDRO, 9 May 1933.

Photo SFMNHP SCR: 55n p106n

Tugboat HERCULES

1925, September
Damage and Repair

Propeller suffers damage and is replaced at Moore Drydock.

Source: Western Pacific Railroad. HERCULES Boatlog, vol. dated 3 May 1925 - 26 February 1926 (SFMNHP Catalog No. 11807). Highly reliable.

Ca. 1932
Alterations

At some point during her service with Western Pacific Railroad, HERCULES' foremast and anchor davit were removed. The 1923 photograph at Moore Drydock (B4.8253) shows both fore and main masts stepped. The wireless shacks, antenna, and anchor davit are still in place. A photograph dated 9 January 1932 (B5.21,068n) shows her at work with only her wooden mainmast in place, and wireless gear and anchor davit removed. Wireless would not have been necessary for harbor work and was probably removed shortly after HERCULES began this phase of her career. The anchor davit was probably removed because of the lack of need for anchoring in the Bay.

Source: Proctor, J.W. 1932 (SFMNHP Photo No. B5.21,068n).

1933, 25 May
Collision and Repairs

HERCULES in collision with McCormick lumber steamer POINT SAN PEDRO near Grove Street Terminal, San Francisco; tug sustains considerable damage to bow, propeller, stern frame, and rudder. Hauled out at Moore Drydock for repairs.

Source: *San Francisco Chronicle*. 26 May 1933.

Moore Drydock Company. 29 May 1933 (SFMNHP Photo Nos. SCR:55N p107n and SCR:55N p106n). Highly reliable.

Fig. 10. Rudder and propeller damage resulting from collision with steamer SAN PEDRO.

Photo: SFMNHP SCR: 55N pg 107



Fig. 11. The first attempt at a doghouse, or raised viewing position, can be seen just above the pilothouse top, on the starboard side.

Photo: Roy Taft



1934, 24 February
Collision

"Hit barge in tow of gas tug while backing out into Oakland slip. Smashed after starboard end of house" (WPRR).

Source: Western Pacific Railroad. HERCULES Boatlog, volume dated 6 November 1933-3 February 1935. SFMNH Catalogue No. 11809.

1934-1939
Alteration

A "doghouse" is added to top of the pilothouse, and a steel mast replaces the original wood mainmast. HERCULES' most significant change in configuration was occasioned by the need to provide visibility for the helm over the top of the railroad cars which were on barges towed "on the hip" (lashed to the starboard side of the tug). Her original low pilothouse was adequate for long tows astern and was actually preferable for the rough conditions on the open sea, especially the steep seas encountered at the shallow bars which crossed many West Coast harbor entrances. "The reason the bar boats had a low house, or sometimes didn't have houses at all, was that you couldn't keep a house on them" (Grey 1965).

Fig. 12. At dock with Western Pacific Railroad Barge No. 3 made fast to starboard side. The second-generation doghouse is mounted above her pilothouse. The pilot house paneling has been covered over with horizontal tongue and groove sheathing. Note the original bow chock and stump of foremast. Photo: Arlie Roberts, ca. 1940.

Photo: SFMNH P85-054.

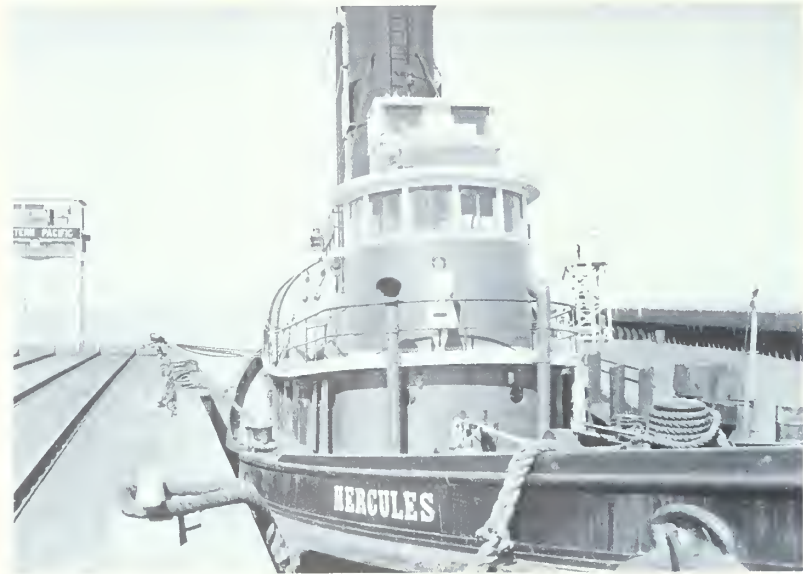

Fig. 13. HERCULES towing Western Pacific Railroad Barge No. 3 in Oakland Estuary.

Photo by H. Dring, undated.
SFMNH B5.23,607n



Collisions like the one reported in February of 1934 may have brought home the need for a higher steering station in the car float service. A photograph ca. 1935 shows HERCULES with a small doghouse added to the top of the aft portion of the original pilot house. A later photograph shows a somewhat larger doghouse atop what is presumably her original pilothouse, although the decorative wood paneling which formerly covered the forward part of that structure has been replaced with horizontal tongue and groove sheathing (Roberts). This photo also shows a steel mainmast.

Source: Gray, J. 1965. Transcript of conversation with Karl Kortum. Reliable reminiscences by son of a West Coast tugboatman.

Taft, R. ca. 1935. Photograph from the Taft collection. Subject clearly visible, date uncertain.

Roberts, A. ca. 1934-1940. Photograph (SFMNH Photo No. P85-054.3n) showing HERCULES with Western Pacific barge No. 3 alongside. Subject clearly visible, date uncertain.

1941, September-October
Alteration

The second stage of the vessel's conversion to railroad work was the fitting of a raised wheelhouse and captain's cabin. The plain steel construction involved no exterior wood paneling, and required some adaptation of the steering engine. The work was performed at Moore Drydock.

Source: Moore Drydock Company. September 1941. Photograph (SFMNHP No. P87-001.31n) showing pilot house deck partially removed and steering engine exposed.

Moore Drydock Company. October 1941. Photograph (SFMNHP No. P87-001.45n) showing staging around newly constructed wheelhouse. Both photos are reliable as to date and features shown.

Fig. 14. HERCULES' new steel captain's cabin and wheel house under construction, Moore Drydock, October 1941.

Photo: SFMNHP P87-001.45

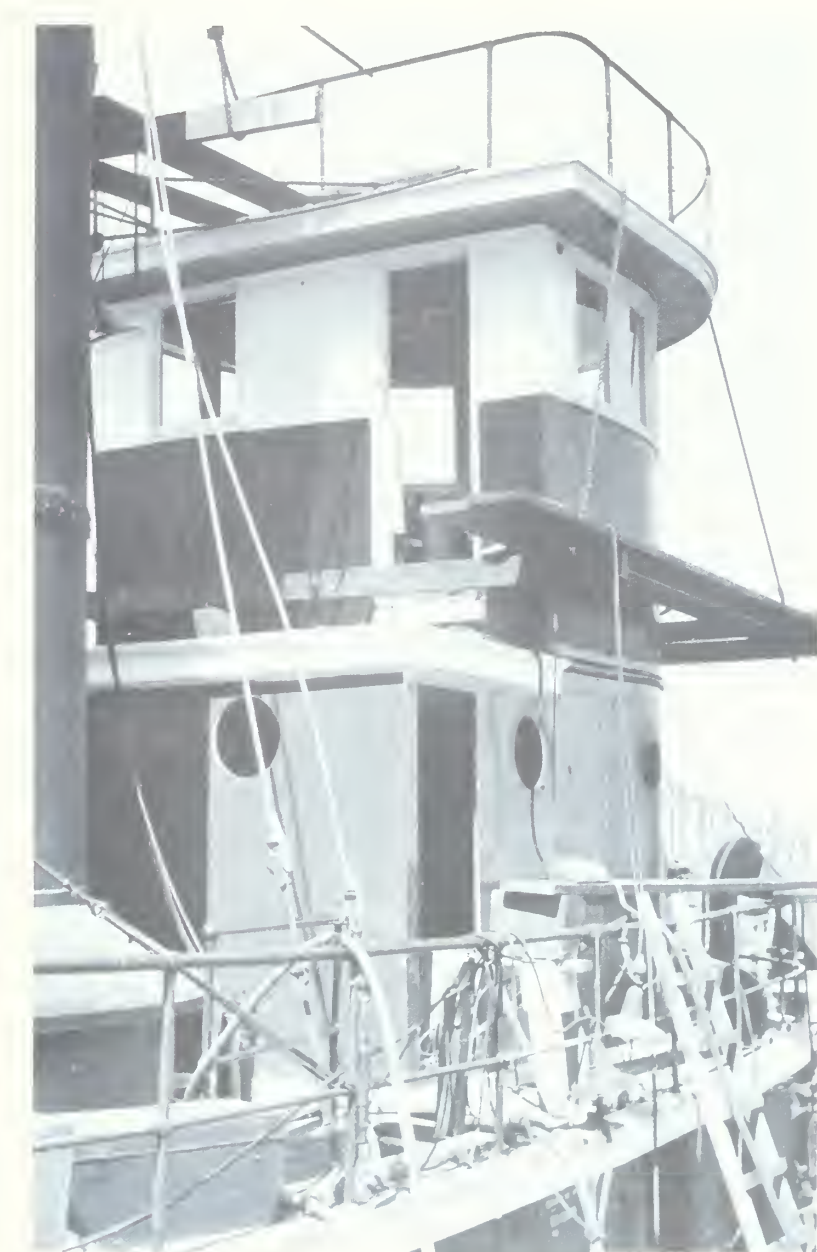

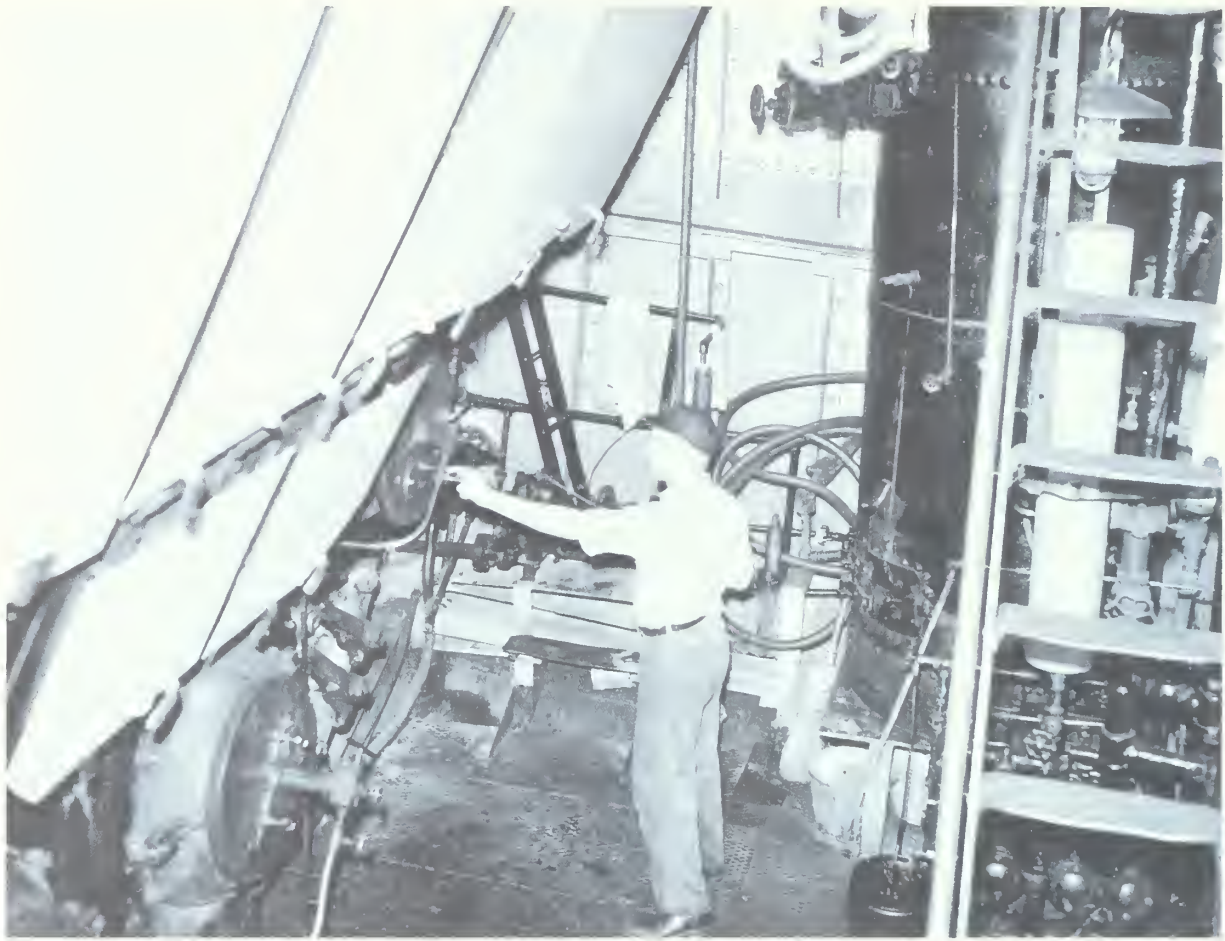

Fig. 15. Boiler room of HERCULES, crew member Howell Roberts (brother of photographer), ca. 1935-1940. Donkey boiler is visible at right (starboard side) beyond ladder to main deck engine room grating.
Note: This is approximately the view afforded to the public from the gallery addition proposed in the section "Interpretation" of this report.

Photo: Arlie Roberts. SFMNH P85-054.6

1941-ca. 1950s
Alterations

Two alterations were made to better suit the vessel for towing barges alongside, but cannot be accurately dated. Her bow chocks or hawse holes through the bulwark forward were greatly enlarged from the oval casting seen as late as 1941, and an arrangement of roller fairleads was fitted (MacGregor ca. 1941). These are in place today and are obviously welded additions. The enlarged openings appear in a photo dated "1950s" (Taft).

The second alteration during this period was a welded reinforcement to the upper guard, on the starboard bow (HERCULES seems to have typically carried her barges on the starboard side), approximately thirty feet long and beginning about twenty feet abaft the stem.

Late in this period (ca. 1950s), a metal awning or visor was added under the overhanging roof of the pilot house, as was a rope bow fender (Taft ca. 1950s). Source: Unaccredited photograph. February 1940 (SFMNHP Photo No. P87-001.02n). Reliably dated, clearly shows original configuration of bow chock and rub rail.

MacGregor, B. ca. 1941. Photograph published in *HERCULES Mileposts* vol. II-3, December 1987, "courtesy Bruce MacGregor collection." Although the caption states "circa 1941," the final modification of her wheelhouse dates the photo after October 1941. This photo clearly shows her originally-configured bow chocks. The starboard rub rail cannot be clearly seen.

Taft, R. ca. 1950s. Photograph published in *HERCULES Mileposts* vol. II-3, December 1987, captioned "Ready for drydocking, 1950's." Reliably shows enlarged bow hawse, reinforced rub rail, bow fender and pilot house awning. Date is questionable.

Ca. 1935-1961 Alteration

The donkey boiler is removed from the boiler room. Two photographs of the boiler room show the location (starboard side, aft), and later absence, of the donkey boiler described as part of her original equipment in the *Nautical Gazette*, 1908. The dates of both photographs are uncertain, and the date of the removal of the donkey boiler therefore cannot be determined with accuracy.

Source: Roberts, A. Undated photograph (no SFMNHP number) of boiler room, looking to starboard. Donkey boiler may be clearly seen on starboard side, beyond boiler room ladder. Reliable as to features shown. Date of event not certain.

Oliveri, W.J. ca. 1954-1961 (SFMNHP PhotoNo.P85.053.1n). Photo taken from similar viewpoint as above shows absence of donkey boiler. Reliable as to features shown, date of event not certain.

Fig. 16. Boiler room, ca. 1954-1961. Note absence of donkey boiler.

Photo: William J. Oliveri (person at left) SFMNHP P85-053.1n



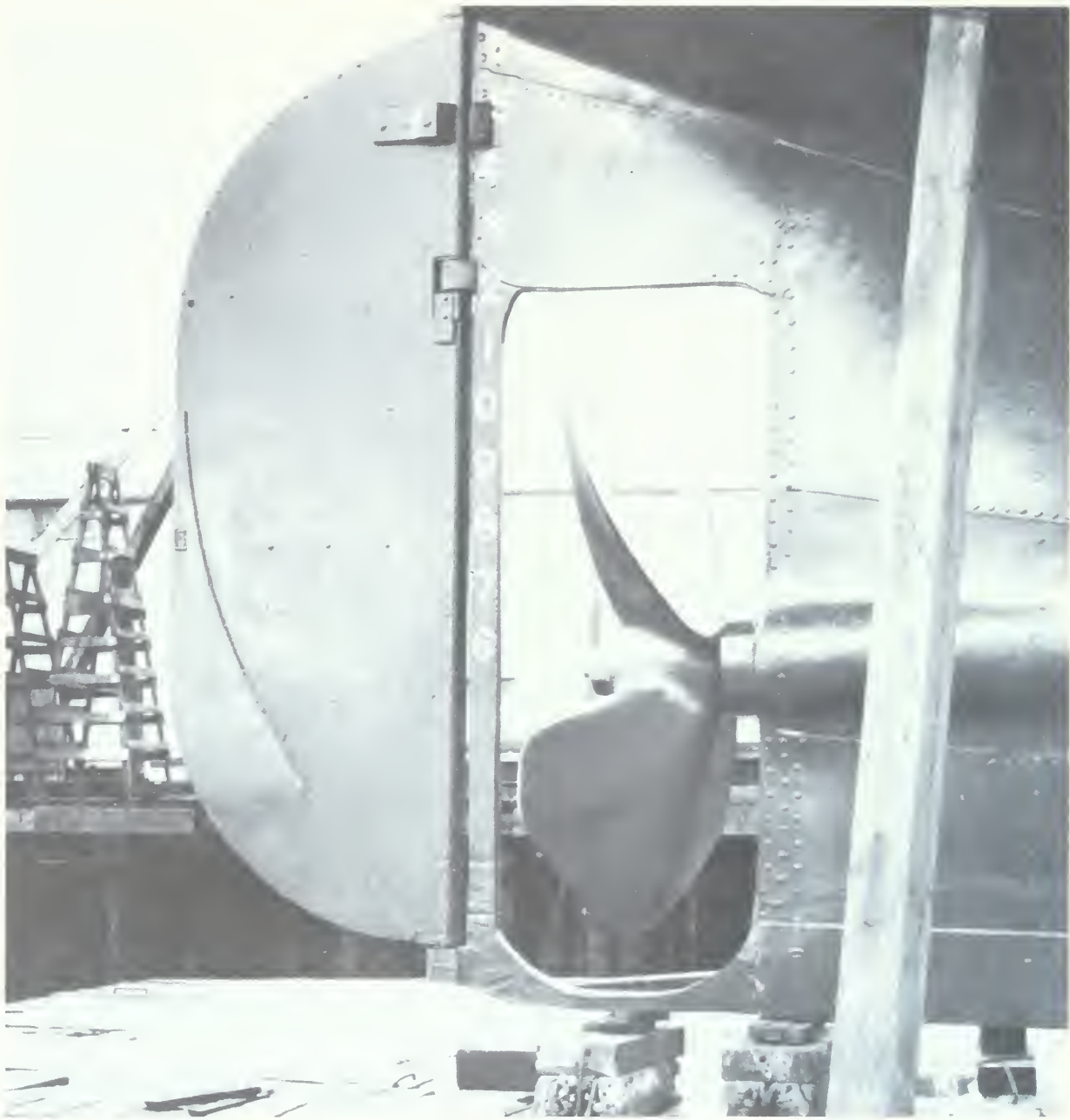

Fig. 17. HERCULES in drydock for enlargement of her rudder, Oakland, California, February 1940. Added portion can be seen at lower left side of rudder.

SFMNHP P87-001.68n

1948, February
Alteration

Rudder area increased approximately 17% by addition to lower aft edge of rudder.

Source: Moore Drydock Company. February 1948. Photo (SFMNHP No. P87-001.68n) clearly shows new rudder configuration. Reliable as to work performed, questionable as to date.

1950
Alteration

"Radio installed on tug HERCULES and in working order" (Western Pacific 1950). This is very likely the first installation of communication equipment since removal of the wireless, ca. 1924.

Source: Western Pacific Railroad. 1950. HERCULES Boatlog, volume April 1949 - June 1951. Entry in log dated 21 February 1950. Highly reliable as to event and date.

1961
Change of Ownership

Sold to Thomas and Brown Shipbuilding Company, Oakland, California, and the Alaska Aggregate Corporation of Anchorage, Alaska. Her new owners planned diesel conversion of the vessel.

Source: *San Francisco Chronicle*. 22 September 1961. Reliable.

2-2.3. Lay-up and Service as Museum Vessel: 1962 to Present

1962
End of active service

“Her Western Pacific service ended in 1962 when her boilers (sic) were condemned” (Dring 1973). Sold to John Seaborn, the Seaborn Towing Company. In 1972 she was “loaned” to S.F. Maritime State Historic Park, while efforts to purchase her moved forward.

Source: Dring H. 1973. Letter to California Historical Society, dated 29 August. Reliable, though he omits the episode of ownership reported by the *Chronicle* above.

1975
National Register

HERCULES is placed on the National Register of Historic Places.

Fig. 18. HERCULES and HUMMACONNA at Western Pacific pier, August 1957. Roller chocks added during Western Pacific Railroad years are visible through enlarged bow hawse, as is the attachment of rope bow fender.

Photo: Karl Kortum. SFMHP B2.524 #6n



Tugboat HERCULES

1975, 23 July
Change of Ownership

Purchased by California State Parks Foundation for inclusion in the California State Historic Park at Hyde Street Pier. Included in the purchase price of \$33,333.33 were a steam-powered circulating pump (which had been removed by John Seaborn and installed aboard his tug RESPECT) and a skiff not original to the vessel.

Source: Bell H. 1975. Letter from Bell (attorney for State of California) to Patmont & Meyers, Insurance, dated 8 July. Reliable.

1975
Haul-out, Restoration and Repair

Work included the return of the paint scheme to the "Red Stack" colors (black topsides, dark red deckhouse, and red smokestack), the removal of the Western Pacific emblem from the stack, and the epoxy filling of wasted rivet heads (as well as routine cleaning, painting, and minor repairs).

Source: State of California. 1975. Contract document dated 10 September.

1976 June
Restoration

By this time, all auxiliaries were "operable," running off a 90-pound, 75 cfm air compressor. Auxiliaries included steering engine, steam capstan, pumps, generators, and whistle. The main engine had been overhauled and well lubricated, and turned over with hand-jacking gear.

Source: Dring H. 1976. Letter to O.C. Thomsen, 22 July. Highly reliable.

1982
Restoration

A continuous doubler plate measuring 36" x 5/16" was welded full length along port and starboard topsides at the area of wind-and-water. Voids behind the doubler were filled with compound to prevent corrosion.

Source: Van Riper, V. 1986. "Survey of Tug HERCULES," dated 9 July. Reliable.

1983, August
Alteration for Public and Staff
Safety

Asbestos insulation removed from steam pipes.

Source: National Park Service. 1983. Signed Contract for asbestos removal from HERCULES (\$3,500), and EUREKA. In Dring files at SFMNH. Reliable.

1985, June
Restoration

Bridge and engine room telegraphs are mounted in vessel, replacing original pieces stolen from vessel. Charles Hopkins donated the engine room telegraph; the wheelhouse telegraph came from the steam schooner KLAMATH.

Source: Museum Technician. 1985. Memo to Supervisory Curator, dated 10 June. Reliable.

Hoskins, C. 1989. As a volunteer involved in this work, Hoskins' account is considered highly reliable. Written review of draft Physical History text. October 1989.

1986

HERCULES designated a National Historic Landmark.

1988

HERCULES moved from Hyde Street Pier to berth at Lower Fort Mason for continued restoration work.

1975 to Present
Restoration and Maintenance

Since her acquisition by the California State Maritime Historic Park in 1975, and through her subsequent acquisition by the National Park Service and the San Francisco Maritime Historical Park, HERCULES has undergone more or less steady preservation, maintenance, and restoration by Park staff and especially by a dedicated group of volunteers. While too numerous to list in detail, these efforts have included:

- Historical research and the initiation of contacts with persons connected with the vessel's active career
- Scaling and repainting deckhouse and some interior compartments
- Scaling boat deck with roofing material
- Scaling and painting stack and mast

- Welding doubler plates over holes in main deck, and scaling and coating deck
- Sandblasting and painting pilothouse
- Stripping the originally varnished paneling in the engine room
- Restoring, replicating or reinstating various small items of equipment such as signal bells and engine room telegraph
- Opening up engine, inspecting, and lubricating
- Research, preparation, and considerable work in returning the boilers to steaming condition, including removal of lagging, scaling of boiler shell, re-tubing of boiler and repair of boiler saddles
- Overhaul of boiler valves and associated pumps and machinery
- Installation of electric air compressor in boiler room
- Overhaul and restoration of the galley stove to operating condition
- Overhaul of towing engine
- Fabrication and installation of new engine room deck plates
- Fabrication and installation of new hot-well and atmospheric drain tank
- Installation of smoke, bilge, and security alarm systems
- Installation of impressed current cathodic hull protection

Source: HERCULES volunteers. 1987-1989. *HERCULES Mileposts*, vols. I-III. Reliable.

Hoskins, C. 1989. Written review of draft Physical History. Reliable.

Fig. 19. HERCULES at her berth along east side of Hyde Street Pier, ca. 1981. In 1988 she was moved to Lower Fort Mason.



2-3. Existing Condition

2-3.1. Particulars

Dimensions as taken in 1989:

Length overall	151.0 ft.
Beam	26.1 ft.
Depth	18.0 ft.
Draft (approx.)	
forward	9.0 ft.
aft	15.8 ft.
Gross Tonnage	409*
Net Tonnage	120*

* Numbers seen stamped in deck beam forward of boiler room.

2-3.2. General Arrangement

HERCULES is of riveted-steel construction and is characterized by a plumb stem, high sheer, counter stern, and long deckhouse. Her major alteration from original configuration is the replacement of her wooden pilot-house with a raised steel one. Her hull is narrow and deep for her length, and is typical of seagoing tugs of her period. Her machinery consists of a single-end, four-furnace, oil-fired Scotch boiler, and a triple-expansion engine.

HERCULES was designed for oil firing and long distance steaming. Her hull is therefore largely devoted to tankage of boiler feed water and fuel oil. The forepeak, from frames 1 (stem) to 8, was used for feed water. The

Fig. 20. HERCULES in her temporary restoration berth at Lower Fort Mason.

Photo: Tri-Coastal Marine



forehold, frames 8 to 23, has a t'ween deck occupied by the windlass engine room, crew's forecastle, and small storerooms. Beneath this deck is the chain locker and a potable water tank.

The boiler room, frames 23 to 36, is aft of the forehold, being separated from it by a non-watertight bulkhead in which an access hatch has been cut. The boiler room is dominated by the single Scotch boiler. Aft of the boiler room and approximately midships, frames 36 to 51, are the fuel tanks. The tanks are integral with the hull and are full depth, from the deck to the keel. They are divided by a longitudinal centerline bulkhead into the port and starboard tanks.

The engine room, frames 51 to 70, contains the majority of the auxiliary machinery as well as the triple-expansion main engine. A shop and tool locker is located at the upper operating platform level, across the after half of the engine room. According to historic markings, this space was originally used as a "crew's wash room." Aft of the engine room are two full-depth water tanks, the aft peak tank from frames 70 to 77, and the lazarette tank from frame 77 to the stern. The transom, at frame 80, has radiating cant beams framing the counter abaft the stern post.

The main deck and bulwarks are riveted steel. Numerous doubler plates have been added over the years as the original plating has wasted away due to corrosion. The fore and aft ends of the bulwarks have been modified to accept fairleads for tow cables. The wood cap rail, which originally ran the perimeter of the vessel, is now missing in places. Outboard are an upper and lower level of guards (rubrails). At the bow is a single-post bitt with cross arms and an anchor davit set in it. Aft of this is the steam-powered anchor windlass.

The deckhouse is a riveted-steel structure with a wood top which forms the boat deck. It is approximately eighty-five feet long and contains the crew's mess, galley, the upper level of the boiler and engine rooms, and cabins for officers and crew. There is a centerline passage between the boiler room and the engine room. An enclosure for a head is located abaft the engine, to port. In the aft end of the deckhouse is the winch room which houses the massive towing engine. On the deck abaft the deckhouse, there is a steam capstan to port and tow bits on centerline. The large quadrant for the steering gear occupies the aft end of the deck.

The boat deck is a canvas-covered planked deck which is enclosed by a two-course pipe railing. The only access to the boat deck is a stair set into the deckhouse on

the forward starboard side. The welded steel pilothouse is located at the forward end of the boat deck. It has two levels: the lower level housing the master's cabin and steering engine, and the upper level, or wheelhouse, serving as the piloting station. The wheelhouse is reached by an exterior ladder. Aft of the pilothouse is the stack and vents for boiler room and fuel tanks. Aft of the stack, a lifeboat is located to starboard, and a work skiff to port, each with a set of radial davits. The steel mast for towing lights, and the engine room skylight are located on centerline. No evidence remains of the two small shacks (for the wireless equipment and battery) which were mounted on the boat deck at one time.

2-3.3. Summary of Existing Condition

HERCULES is largely intact and has remained essentially unchanged since the end of her working career in 1962. Her present condition varies from good to marginal, and appears to be relatively stable, with exception of the boat deck, main deck, and portions of her hull. The condition and rate of deterioration of the underwater hull cannot be fully determined without drydocking.

Much of the deterioration seen in HERCULES appears to predate her acquisition by the San Francisco Maritime State Historical Park in 1972. Physical evidence indicates that maintenance was deferred during the latter part of her working career. Repairs made in this period are of lesser quality and were probably carried out with the intent of squeezing a few more years of service out of a tired old vessel.

Although efforts by the NPS to preserve HERCULES have been limited, there has been consistent volunteer involvement since the late 1970s. The major focus of their work has been the boiler and auxiliary equipment, and in the last two years some of that equipment has been returned to operational condition.

The assessment of existing condition is based on surveys performed by Tri-Coastal Marine in 1987 and 1989. This summary is divided into the major components of hull, superstructure, machinery, and equipment. A more detailed accounting of condition is given in Appendix 3-1. Survey Findings.

2-3.3.1. Hull

The overall condition of the hull is fair, yet some severe deficiencies exist. The frames, beams, stringers,

and bulkheads are in reasonable condition, except where they are adjacent to water tanks or below the cement in the bilges. In the area of the forepeak and afterpeak tanks, the hull is covered with thick rust scale and has suffered appreciable wastage. While precise condition cannot be determined until scale is removed, it is reasonable to expect an overall loss of material of between 25% and 33%. Fortunately, these tanks represent a small portion of the overall hull and are located in the ends of the vessel where hull girder strength is less affected by such wastage.

The framing below the cemented bilges of the forehold, boiler room, and engine room is suspect; heavy rust scale is seen in these areas and corrosion may be ongoing below the cement.

To summarize condition of the shell plating, the hull can be considered as four distinct longitudinal bands:

1) The sheer strake and upper topsides are generally sound, with little exterior or interior corrosion. A

greater degree of corrosion exists in the band of shell plate behind the chafing guards, though this is not considered critical to hull integrity.

2) The area of the wind-and-water line was found to be dangerously thin during drydocking in 1982, and the problem was corrected by installing a belt of welded doubler plates.

3) The shell below waterline and above the turn-of-bilge has suffered from external pitting and corrosion over the years, but still averages .250" or better. This is sufficient for hull strength and watertight integrity, but gives little allowance for additional wastage.

4) The area below the turn-of-bilge has suffered similar exterior corrosion and has also been subject to internal corrosion due to the free movement of bilge water. Internal corrosion is severe in areas where the hull is difficult to maintain due to limited access.

Fig. 21. Wastage typical of that seen in local areas of HERCULES' deckhouse.

Photo: Tri-Coastal Marine



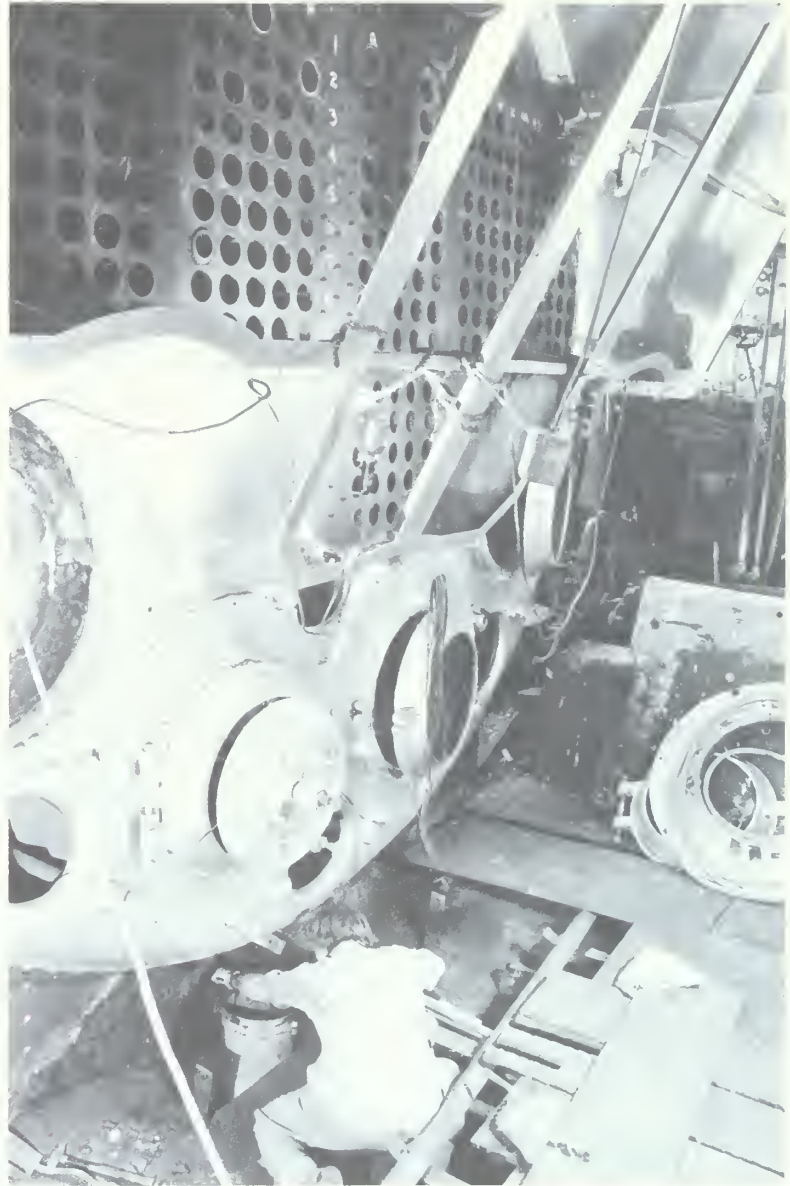

Fig. 22. View of the front end of HERCULES' boiler during restoration in the mid-1980s. Doors of the "front connection" have been removed for replacement of fire tubes.

Photo: L. Newcomb

A rough assessment of the shell is that approximately 50% of the total hull area (the upper topsides and upper bottom) is adequate; another 25% (the wind-and-water line) has been repaired and is stabilized; and an additional 25% (below the turn-of-bilge) remains dangerously thin. This last portion presents a serious problem; failure to drydock and repair the hull will result in further deterioration and an increase in the danger of sinking.

The original riveted-steel deck has been repaired with welded doubler plates over the years. The deck shows evidence of corrosion and pitting, though some areas have recently been stabilized by sandblasting and painting. The bulwarks remain relatively sound, but are

unsightly due to later welded additions, and damage to the original structure. The guards along the hull, port and starboard, are in poor condition and continue to deteriorate. The steel portions are rusting away and the wood members are rotting and contributing to wastage of the hull beneath. Preservation and repairs will be required to prevent further deterioration of the deck, bulwarks, and guards. Restoration is recommended for the long-term, but is not considered an immediate priority.

2-3.3.2. Superstructure

The superstructure consists of the steel deckhouse, wooden boat deck, steel pilothouse, and stack. The deck-

house shows numerous localized areas of corrosion and wastage, none of which require immediate attention other than stabilization. All such areas will need to be repaired in order to restore and maintain the deckhouse.

The boat deck is leaking in many places, and is contributing to deterioration of structures below. This deck has been covered with roofing material in an effort to stop leakage. Permanent repair will require renewing at least one-third to one-half of the deck.

The pilothouse is in fair condition, inside and out. The roof of the pilothouse, like the boat deck, is rotten and has been covered over with roofing material. The exterior of the pilothouse has recently been painted.

The stack appears to be in fair condition overall, although a complete inspection has not been made due to limited access to the interior. There are numerous local areas of corrosion on the stack exterior. The portions of the interior which can be seen are in fair condition. The stack should undergo major preservation work, including structural repairs, but is not considered an immediate liability.

2-3.3.3. Machinery

The machinery is largely intact, and almost all of the pieces are still in place. At the time HERCULES was acquired as a museum ship, many of the elements, including the boiler, auxiliaries, and associated valves and piping, were worn out by years of service and minimal maintenance. Some of these elements have been rebuilt since 1976, others are in the process of overhaul. The main engine is complete and rotates freely. The condenser is presently disassembled and is being re-tubed. Most of the auxiliaries are complete and have been tested on compressed air in the last few years. The boiler has been re-tubed, and hydro tested (pressure tested using water), and is being readied for operation at reduced pressure.

The foundation of the main engine is severely wasted in the area of the bilge cement. Further survey is necessary before an accurate determination can be made as to condition and need for repairs. The boiler saddles were also severely wasted, but have been partially repaired. The webs supporting the saddles will require further welded repair. The fuel tanks are in good condition internally, but are no longer tight at the deck and bulkheads. They are therefore not considered suitable for holding fuel. The tanks are presently being used for water ballast.

The anchor windlass is missing many of its important elements, but the remaining portions, including the foun-

dation, shaft, and warping heads, are in good condition. The towing engine has been partially overhauled and is intact.

The electrical wiring is a mixture of old and new wiring and fixtures. The portions of the system in use today are only marginally suitable for the ongoing restoration work. The condition of much of the steam, water, and fuel piping is not known and cannot be determined without testing. The main and auxiliary steam lines have been tested under pressure, but may require further testing to determine if they have become brittle through years of service. If so, they will have to be annealed before they can be reactivated.

On balance, it is extremely fortunate that all major components of the vessel's machinery are in place and are either intact or repairable.

2-3.3.4. Equipment

Most of the equipment which was permanently secured to the vessel, such as davits and bits, is still in place. Other items, like the ship's bell, have disappeared. The original steering pedestal and wheel are mounted in the wheelhouse, along with a nearly identical replacement for the original engine room telegraph, which has been lost. The historic name boards are in museum storage. Numerous other items, such as interior furnishings, will have to be reproduced.

2-3.3.5. Conclusions

HERCULES' existing condition makes possible a variety of treatment alternatives. These range from restoration as a static exhibit to reactivation as a fully-operational steam vessel. The most immediate preservation need is the stabilization of those elements which are continuing to deteriorate unabated. This will require dry-docking for hull repairs, weatherproofing of decks, and preservation of machinery and interior spaces.

2-4. Significance of Fabric and Features

2-4.1. Background

HERCULES is recognized as a significant cultural resource, having been placed on the National Register of Historic Places in 1975, and given National Landmark Status in 1986. She is one of only seven remaining steam tugs in this country, and one of the two remaining ocean-going steam tugs (Brouwer 1985).

The vessel is remarkably intact and has undergone few alterations since her launching in 1907, thus retaining a large percentage of her original fabric. She managed to avoid the fate of many steam tugs—conversion to diesel power—and came into Museum hands with a nearly complete inventory of steam equipment.

HERCULES was designed and built for ocean towing and served in this capacity from 1907 to 1924. She remained essentially unaltered during this time, with the exception of the installation of wireless equipment. The purpose of HERCULES' form and features is best reflected during this period, most of which was spent under the ownership of the Merchants and Shipowners Tug Boat Company. This is also the period in which she achieved national, regional, and local significance. Her national significance lies in the fact that she was involved in the construction of the Panama Canal. She earned regional significance through her years in coastwise service, ranging the length of the West Coast of the United States. Local significance comes through her homeporting in San Francisco Bay. The rest of her working career (1924-1962) was spent exclusively on San Francisco Bay, primarily moving rail car barges. She gradually underwent alteration to better suit this purpose. This period has historic significance on a local level. The period of lay-up that followed (1962-1972) is not considered historically significant, nor is her period under museum ownership.

2-4.2. Purpose and Methodology

The assessment of significance of the various physical elements of the vessel is intended to establish which elements contribute to the overall significance of the vessel. In addition, the assessment will identify those elements that do not contribute, or that adversely impact overall significance.

The assessment of significance should serve to:

- 1) Guide preservation, restoration, or reconstruction efforts.
- 2) Help insure that treatment does not adversely impact significant elements.
- 3) Focus documentation efforts on significant, rather than nonsignificant, elements.
- 4) Allow a more representative and informative interpretation of the vessel.

The significance of the individual physical elements of HERCULES has been rated according to the following definitions.

Highly Significant Elements: Elements which were incorporated in her original construction, or which date from her most significant period (1907-1924). At the top of this list are prominent elements which are major contributors to the historic character of the vessel, and unique elements manufactured specifically for the vessel.

Significant Elements: Additions, replacements, or alterations made during her later working period (1924-1962).

Nonsignificant Elements: Additions or alterations made after her working period (1962 to present).

Information on the origin and present state of physical elements is taken from the physical history research and from the survey of existing condition.

2-4.3. Rating of Elements

The following physical elements have been rated in descending order of significance. A general assessment of condition is given for each element, along with comments on the factors that affect significance.

2-4.3.1. Highly Significant Elements

Prominent and One-of-a-Kind Elements

These elements are considered of greatest significance due to their uniqueness and the degree to which they contribute to the historic character of the vessel.

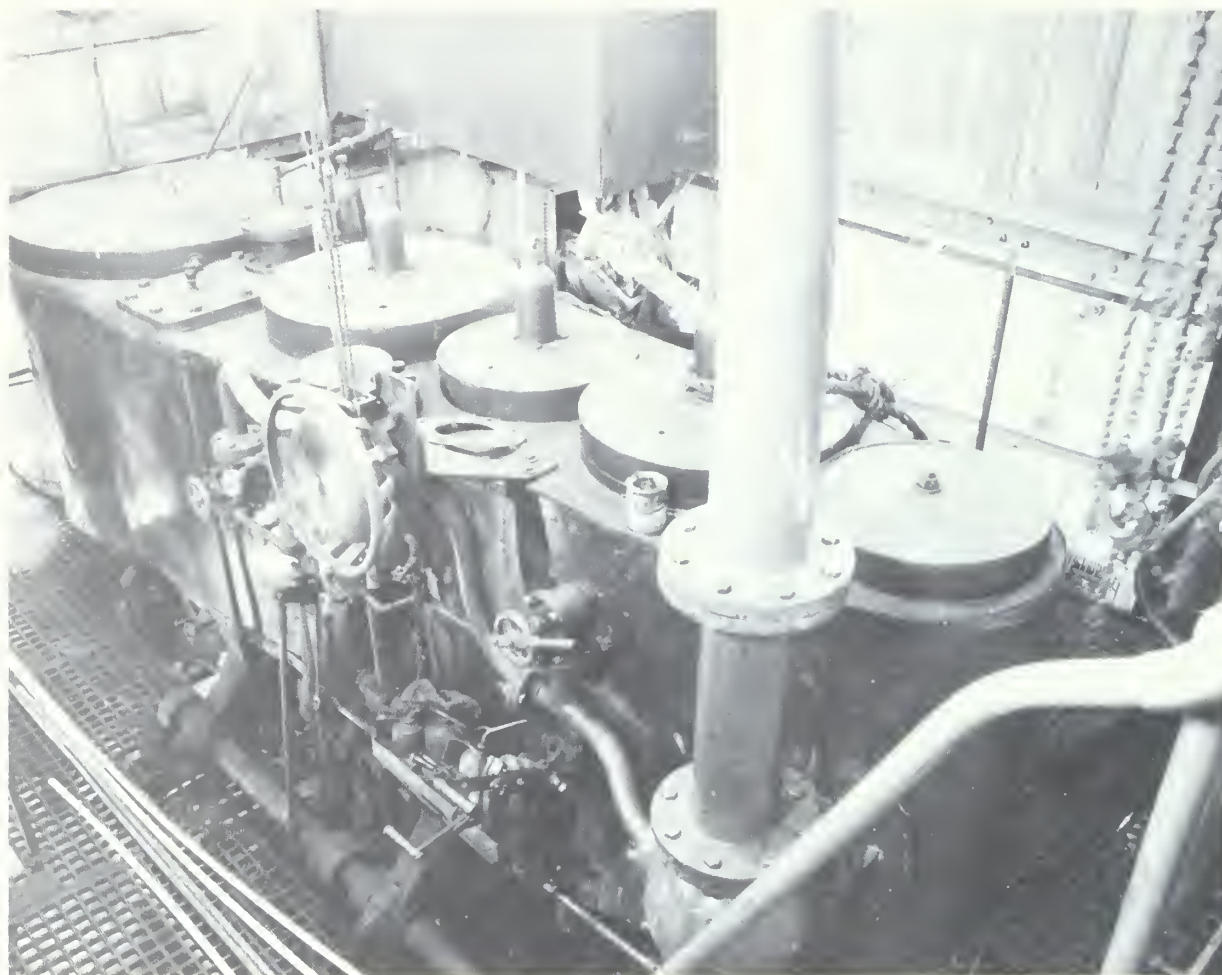

Fig. 23. HERCULES' triple-expansion engine—the “centerpiece” of her historic machinery—as viewed from the forward port side. Note cherrywood engine room paneling at upper left and right.

Photo: Tri-Coastal Marine

Hull, Including Maindeck, and Bulkheads: Intact and original, except for addition of a starboard guard rail (ca. 1941-1950), and the installation of a doubler plate along the waterline (1982). The maindeck has been repaired with welded plates which affect its original appearance. The forward boiler room bulkhead has been breached for access to the forecabin. These changes have resulted in only minor impact to the overall historic integrity of the hull.

Deckhouse: Intact and original with exception of the addition of steel deck beams over the forward end of the house (1941), and minor alterations to the interior compartments. Some of the exterior steel doors have been replaced during the post-historic period.

Boiler: Intact and largely original; major repairs have been undertaken in the post-historic period, includ-

ing replacement of all boiler tubes and eighteen combustion chamber stay rods, and repair of boiler saddles. These repairs have been made in-kind and have no significant impact on historic integrity.

Engine, Including Condenser, Vacuum Pump, and Beam Pumps: Intact and original with exception of the internal elements of the condenser which have been renewed during the post-historic period.

Equipment, Including Whistle, Ship's Wheel, Steering Pedestal, and Engine Room Gong and Telegraph: Intact and original, with exception of the whistle and telegraph which are later historic additions.

Custom Deck Fittings, Including Bow Bitt, Mooring Bitts, and Towing Bitts: Intact and original, with exception of the anchor davit mounted on the bow

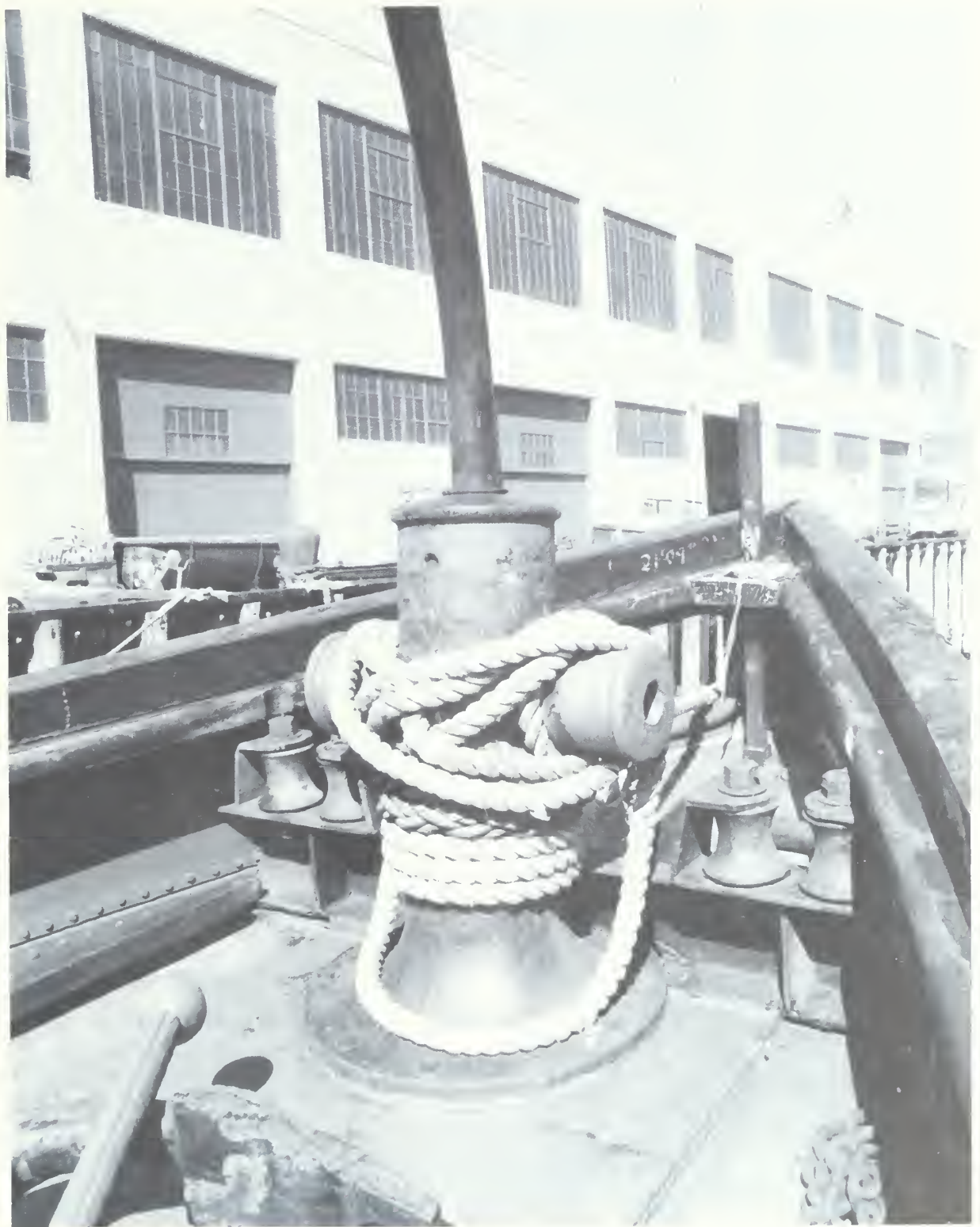

Fig. 24. Kingpost bitt on foredeck, one of several original custom-made items HERCULES is fitted with. Roller-chocks to port and starboard of the bitt are a later addition.

Photo: Tri-Coastal Marine

bitt. The davit was taken from a Pacific Telephone cable barge in the 1970s.

2-4.3.2. Other Highly Significant Elements

These elements are believed to be original to the vessel, but are not unique. Many were manufactured for general marine use and identical examples very likely exist elsewhere.

Deck Machinery, Including Towing Winch, Anchor Winch, and Capstan: Original and intact with exception of the anchor winch which is missing the chain drums, hand pump, and brakes.

Auxiliary Machinery, Including General Service Pumps, Hydrokinetor Pump, Boiler Room Bilge Pump, Feed Water Heater, Injectors, Steam Reciprocating Generator, Boiler Feed Pump, and Main Circulating Pump: Mostly original and intact; various repairs made in post-historic period.

Fig. 25. The smoke stack as viewed from aft. The stack has been rebuilt at least once during HERCULES' working life, as evidenced by a combination of welded and riveted construction, but retains its original form. The tall stack is a significant feature of steam tugs.

Photo: Tri-Coastal Marine



2-4.3.3. Significant Elements

These elements contain little or no original fabric. Some retain their original form but are largely comprised of replacement fabric. Other items in this class are additions or alterations made during the later historic period (1924-1962).

Pilothouse: Intact, dates from 1941, replaced original wood pilothouse. The railing around the top of the pilothouse has been removed, along with the spotlight and running lights. The spotlight is presently in museum storage.

Smoke Stack: Intact and retains original form but has been rebuilt and contains mostly replacement fabric. The tall stack is a characteristic unique to steam vessels.

Mainmast: Intact, exact date of installation unknown, replaces original wood mainmast.

Bulwarks: Partly original, but damaged and altered. Larger bow chocks were installed, ca. 1941-1950.

Propeller and Rudder: Propeller replaced in 1925. Rudder enlarged in 1940. Condition unknown.

Boat Deck and Railings: Intact and in original form, but in poor condition. Railings were probably replaced during the historic period. Skylight is not original but from the later historic period.

Forecastle Accommodations: Not original, date and origin are unknown. The original accommodations were designed for long offshore passages and would have been considerably different from the existing arrangement, which probably dates from the later period of service on San Francisco Bay.

Auxiliary Equipment, Including Turbine Generator, Steam Powered Air Compressor: Intact, added in the later historic period. These items are standard railroad (locomotive) equipment.

2-4.3.4. Nonsignificant Elements

Nonsignificant elements include post-historic additions, alterations, and unauthentic repairs. Some of these items are intended to be temporary and exist only to facilitate the ongoing restoration effort.

Steel Doubler Plates on Hull Exterior: Doubler plates were added along the wind-and-water line in 1982 as

a repair for thin hull plating. These have a visual impact on the appearance of the hull when viewed up close, but are considered a necessary repair.

Electric Compressor: The electric compressor was installed to test the steam-powered auxiliary machinery. This compressor, or one like it, may be needed over the long term to facilitate operation and maintenance as a museum ship.

Shore-power Electrical System: Much of the shore-power system has been installed to facilitate restoration, and is not adequate as a permanent addition.

Exterior Security Lighting and Alarm System: These additions were made for protection of the vessel. They impact historic integrity to a minor degree, but are necessary for protection in the present berth.

Deck-mounted Fuel Tank: This is a temporary addition to hold diesel fuel for test firing of the boiler.

2-4.3.5. Missing Elements

Some prominent elements dating from the most significant historic period (1907-1924) have been removed from the vessel. These elements are worth noting as they contribute to HERCULES' original character and appearance.

Historic Name Boards: These exist and are in fair condition. They are presently in the SFMNH museum storage and are considered highly significant.

Foremast and Original Mainmast: Both of the wood masts were removed during the later historic period. The foremast was probably removed to improve visibility from the pilothouse. The mainmast was likely replaced due to deteriorated condition. It is highly unlikely that either are still in existence.

Donkey Boiler: The donkey boiler was removed sometime between 1940 and 1961. Boilers are durable pieces of equipment and this one may still exist, though its location is unknown.

Lifeboat and Skiff: The lifeboat and skiff that were on board the vessel at the end of her working career have been removed for preservation. Both are believed to date from the later historic period and are therefore significant.

2-4.4. Form and Character

HERCULES' historic form and character are also important contributors to the vessel's overall significance. Form and character are not solely derived from the physical elements listed above and should therefore be assessed individually.

2-4.4.1. Profile

The profile of HERCULES' hull, characterized by the uninterrupted run of sheer with a dramatic rise forward, is an important characteristic of her type. The high bow and low stern were necessary features for towing, particularly when offshore. The profile of the hull remains physically unchanged, though that of her superstructure has been altered by the 1941 addition of a taller pilot-house, a feature which is incompatible with oceangoing service.

2-4.4.2. Arrangement

The interior layout and arrangement of compartments is a product of the vessel's original service as a long distance voyager. The layout of hull and superstructure remains unchanged with the exception of alteration to the steel bulkhead at frame 23, minor changes to wood joiner bulkheads in the deckhouse, and removal of furnishings.

2-4.4.3. Method of Construction

A significant characteristic is the vessel's original riveted-steel construction. Though once common, this method of construction has given way to welded construction in shipbuilding. Today, few riveted vessels remain in the United States. Prominent examples of her riveted structure are seen in the hull, main deck, bulwarks, and deckhouse. Welded repairs made over the years have had an impact on the appearance of each of these items.

2-4.4.4. Color Scheme, Name, and Insignias

The present color scheme is incomplete and does not accurately reflect any historic period. A color scheme, including any insignias, consistent with a single historic period is considered a significant feature.

2-4.5. Conclusions

HERCULES' overall significance can be attributed to the large percentage of historic fabric she retains and the relatively unaltered state of most of her prominent features. HERCULES' period of ocean service (1907-1924) is considered her most significant historic period. The major contributors to overall significance are those elements and features which reflect her origins as an oceangoing steam tug. These are the elements which are judged to be highly significant. Special mention should be given to the steam equipment, including boiler, engine, auxiliaries, and piping. These constitute a rare example of an intact marine steam plant and have potential for use in interpreting this rapidly vanishing form of marine propulsion.

The fact that HERCULES is the last example of her type lends even greater importance to her intact state and suggests that treatment would best be directed toward preserving the integrity of the vessel as a complete entity, rather than favoring a subset of elements.

2–5. Measured Scale Drawings

The measured scale drawings of the Historic Structure Report are the result of documentation of HERCULES between May and October of 1989. The drawings represent the vessel as she appeared during that period, though items temporarily installed onboard to facilitate ongoing restoration were not documented.

The general hull outlines used in the structural drawings are based on hull lines developed from offsets taken inside the hull. The lines were faired by David J. Seymour, Naval Architect. Due to lack of accessibility in some locations of the lower hull, the exact shape and structure of the keel and garboard area of the hull remains somewhat ambiguous. Upon drydocking of HERCULES, a more accurate documentation of these areas will be possible.

ABBREVIATIONS (APPLICABLE TO ALL NOTES)

AP AFT PERPENDICULAR
 APT AFT PEAK TANK
 ARRGT ARRANGEMENT
 AUX AUXILIARY
 BHD BULKHEAD
 BKT BRACKET
 BLWK BULWARK
 BTWN BETWEEN
 CL CENTERLINE
 CIRC CIRCULATING
 CONN CONNECTION
 CTRS CENTERS
 CYL CYLINDER
 DBL DOUBLE
 DISCH DISCHARGE
 DK DECK
 DN DOWN
 DWR DRAWER
 ENG ENGINE
 EXH EXHAUST
 FLG FLANGE
 FO FUEL OIL
 F.O.T. FUEL OIL TANK
 FP FWD PERPENDICULAR
 FPT FORE PEAK TANK
 FWD FORWARD
 HP HORSEPOWER
 H.P. HIGH PRESSURE
 HTR HEATER
 INTMDT INTERMEDIATE
 LKR LOCKER
 L.O. LUBRICATING OIL
 LOC'N LOCATION
 LONG'L LONGITUDINAL
 L.P. LOW PRESSURE
 L.T. LONG TONS (2240 lbs)

M.H. MANHOLE WAS BUILT AS ONE OF TWO NEARLY
 M.P. MEDIAL FULL OCEAN CLASS NARROW-BEAM, DEEP-
 NOM NOMINUGS. SISTERSHIP WAS THE "GOLIAH".
 N.T. NON (INCIPAL AND SERVICE MACHINERY (MAIN,
 O.T. OIL TANK, STEERING, AND WINDLASS ENGINES), AS
 O.V.D. OVERBOARD PUMPS) ARE STEAM-DRIVEN.
 PLATE PLATE AS SHOWN REPRESENTS CURRENT CONDITION.
 P/S PERTURBATIONS SUCH AS ELEVATED PILOTHOUSE,
 RAD RADIA TOWING AND FOREDECK MOORING ARR'G'TS,
 RM ROOM AT CONFIGURATION, FOREMAST REMOVAL, AND
 SGL SINGLE ALTERATIONS ARE DETAILED OR NOTED ON
 STAN STANQUENT SHEETS.
 TK TANK OF SURVEY, VESSEL WAS MOORED ALONGSIDE,
 T&G TONGUE HANGING OFF EAST SIDE OF PIER 'A', FORT
 TRANSV TRANS CENTER, SAN FRANCISCO. SHE IS DEEMED
 TYP TYPICALLY FAIR TO GOOD CONDITION WITH MINIMAL
 VAR VARIOUS OF LEAKAGE. MACHINERY IS EITHER
 VL. VERTICAL OR READILY CAPABLE OF BEING
 W/ WITH RESTORED TO OPERATING CONDITION RESTORATION
 W.L. WATER CURRENTLY ONGOING.
 W.T. WATER
 WTR WATER

STEEL STRUCTURE
 Z ANGLE
 T "T"-SHAPE
 C CHANNEL
 MC MISC. (SPE)

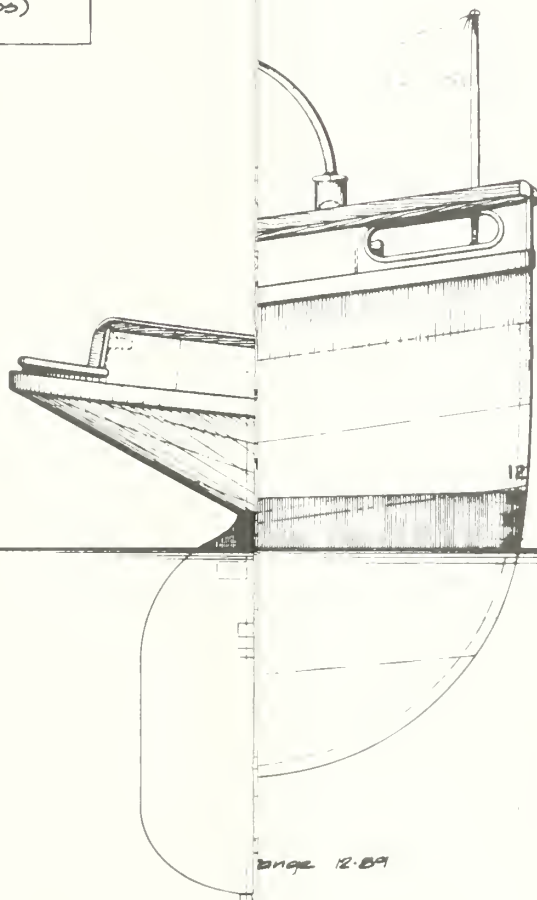

DATE 12-89

BASELINE

AP

CONTRACTOR
 21-COASTAL
 MARINE
 AWN
 D STRANGE
 CHECK REVIEW
 BIRKHOLZ
 DATE 12/89

STEAM TUG "HERCULES"

OUTBOARD PROFILE

SAN FRANCISCO MARITIME
 NATIONAL HISTORICAL PARK

DRAWING NO
 350
 60000

PRG NO SHEET
 1
 OF 5

ABBREVIATIONS (APPLICABLE TO ALL SHEETS)

AP	AFT PERPENDICULAR	M.H.	MANHOLE
PT	AFT PEAK TANK	M.P.	MEDIUM PRESSURE
ARR	ARRANGEMENT	NOM	NOMINAL
AUX	AUXILIARY	N.T.	NON (WATER) TIGHT
BULK	BULKHEAD	O.T.	OIL TIGHT
BRACK	BRACKET	OVBD	OVERBOARD
BULW	BULWARK	PL	PLATE
BETW	BETWEEN	PLATF	PLATFORM
CEN	CENTERLINE	P/S	PORT & STARBOARD
CIRC	CIRCULATING	RAD	RADIATOR
CON	CONNECTION	RM	ROOM
CEN	CENTERS	SGL	SINGLE
CYL	CYLINDER	STAN	STANCHION
DBL	DOUBLE	TK	TANK
DIS	DISCHARGE	T&G	TONGUE & GROOVE
DECK	DECK	TRNSV	TRANSVERSE
DOWN	DOWN	TYP	TYPICAL
DRAW	DRAWER	VAR	VARIOUS
ENG	ENGINE	VL	VERTICAL LADDER
EXH	EXHAUST	W/	WITH
FLANG	FLANGE	WL	WATERLINE
FUEL	FUEL OIL	WT	WATERTIGHT
FWD	FWD PERPENDICULAR	WTR	WATER
FP	FORE PEAK TANK		
FOR	FORWARD		
HORSE	HORSEPOWER		
HIGH	HIGH PRESSURE		
HEAT	HEATER		
INT	INTERMEDIATE		
LOCK	LOCKER		
LUB	LUBRICATING OIL		
LOC	LOCATION		
LONG	LONGITUDINAL		
LOW	LOW PRESSURE		
LONG	LONG TONS (2240 lbs)		

STEEL STRUCTURAL SHAPES

Z	ANGLE BAR
T	"T" SHAPED BAR
C	CHANNEL BAR (STANDARD)
MC	MISC. (SPECIAL) CHANNEL

PRINCIPAL CHARACTERISTICS

LENGTH OVERALL	131'-0"
LENGTH BETWEEN PERPENDICULARS	141'-0"
BREADTH (MOLDED)	26'-0"
BREADTH (EXTREME OVER GUARDS)	27'-6"
DEPTH AMIDSHIPS	18'-0"
DRAFT FWD (SEE SHEET 2, NOTE 1)	9'-0"
DRAFT AFT (" " " ")	15'-6"
GROSS TONNAGE	409
NET TONNAGE	120
BUILDERS	JOHN H. DIALOGUE & SON, CAMDEN, N.J.
YEAR BUILT	1907
MAIN ENGINE	500 HP TRIPLE EXPANSION STEAM RECIPROCATING, BORE: 17", 24", & 41" x 30" STROKE
BOILER	LUKENS 132 TUBE SCOTCH SINGLE-END 177 PSI, 4-BURNER, OIL-FIRED, NATURAL DRAFT.

INDEX TO DRAWINGS

SHEET 1	OUTBOARD PROFILE
SHEET 2	INBOARD PROFILE
SHEET 3	ARR'GT MAIN DECK & ABOVE
SHEET 4	HOLD ARRANGEMENT
SHEET 5	MIDSHIP & MACHINERY SECTIONS

REFERENCES

350/60000 P1	FRESH & SALT WATER PIPING
350/60000 P2	FUEL OIL, LUBRICATING OIL, & COMPRESSED AIR PIPING.
350/60000 P3	PROPULSION & AUXILIARY STEAM PIPING
350/60000 E1	ELECTRICAL SYSTEM

GENERAL NOTES

- VESSEL WAS BUILT AS ONE OF TWO NEARLY IDENTICAL FULL OCEAN CLASS NARROW-BEAM, DEEP-DRAFT TUGS. SISTERSHIP WAS THE "GOLIAH".
- ALL PRINCIPAL AND SERVICE MACHINERY (MAIN, TOW WINCH, STEERING, AND WINDLASS ENGINES, AS WELL AS PUMPS) ARE STEAM-DRIVEN.
- VESSEL AS SHOWN REPRESENTS CURRENT CONDITION. MODIFICATIONS SUCH AS ELEVATED PILOTHOUSE, FAULT TOWING AND FOREDECK MOORING ARR'GTS, LIFEBOAT CONFIGURATION, FOREMAST REMOVAL, AND BERTHING ALTERATIONS ARE DETAILED OR NOTED ON SUBSEQUENT SHEETS.
- AT TIME OF SURVEY, VESSEL WAS MOORED ALONGSIDE, BUT STANDING OFF EAST SIDE OF PIER A, FORT MASON CENTER, SAN FRANCISCO. SHE IS DEEMED TO BE IN FAIR TO GOOD CONDITION WITH MINIMAL EVIDENCE OF LEAKAGE. MACHINERY IS EITHER OPERATIONAL OR READILY CAPABLE OF BEING RESTORED TO OPERATING CONDITION. RESTORATION WORK IS CURRENTLY ONGOING.

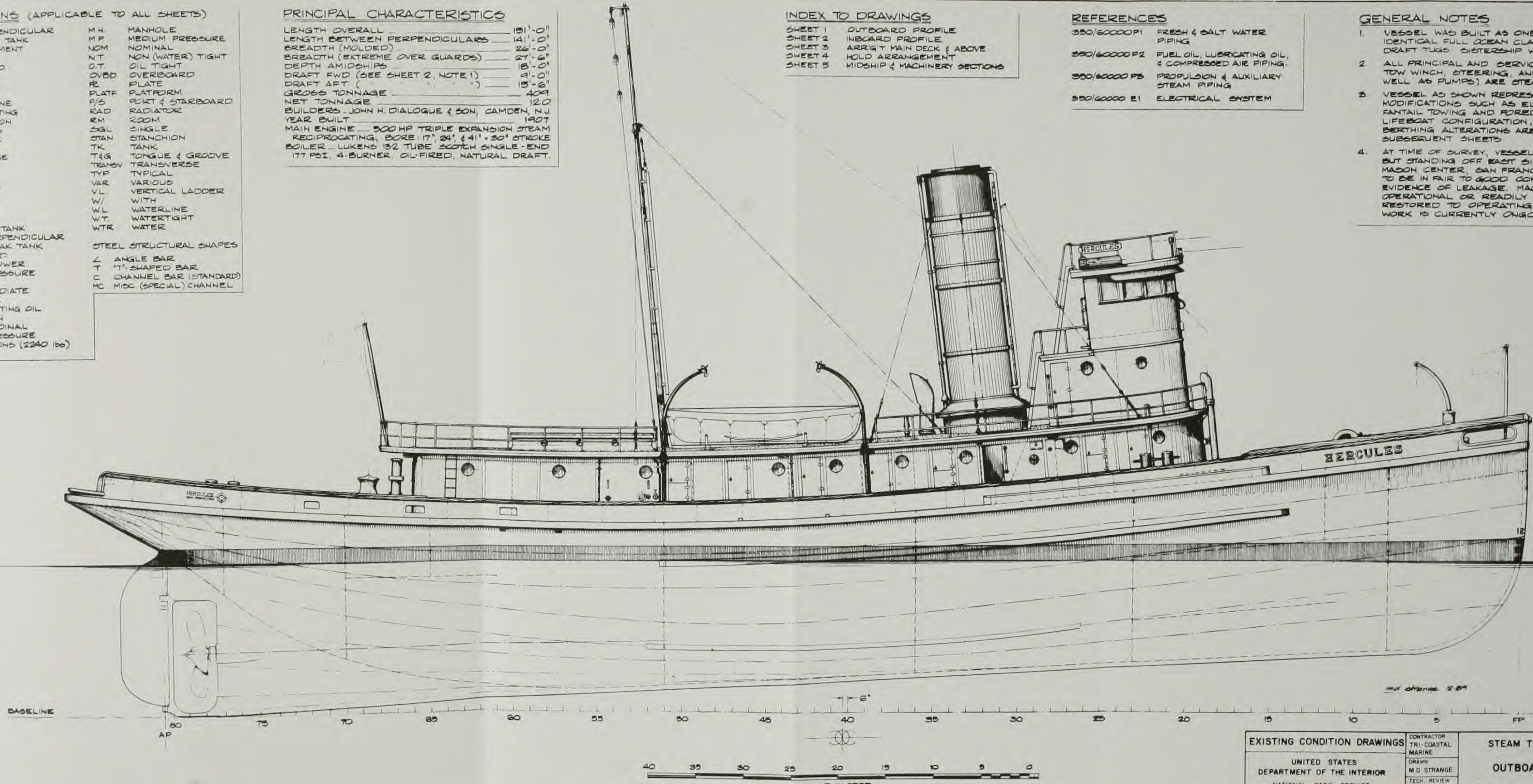

EXISTING CONDITION DRAWINGS	CONTRACTOR	TRI-COASTAL MARINE	DRAWING NO. 350/60000
	UNITED STATES DEPARTMENT OF THE INTERIOR	NATIONAL PARK SERVICE	
STEAM TUG "HERCULES"		OUTBOARD PROFILE	
SAN FRANCISCO MARITIME NATIONAL HISTORICAL PARK		PRG. NO.	SHEET 1 OF 5
DATE 12/89			

NOTES

1. VESSEL IS CURRENTLY MOORED DOCK DRAFT (9'-0" KEEL DRAFT FWD) WITH MIDSHIP FILLED APPROXIMATELY 75 % WITH FRESH WATER AND PEAK TANKS EMPTY. DESIGNED FULL DRAFT ASSUMED TO BE IN THE AREA OF 16'-6".
2. RUDDER AREA WAS ENLARGED OVER OR BELOW) TO PROVIDE INCREASED MANEUVERABILITY UNDER VARIOUS OPERATING CONDITIONS.
3. ALTHOUGH SKEG AND STERNFRAME PROFILES WERE NOT DOCUMENTED FROM PHOTOGRAPHS, THE CURRENT PROFILES SHOWN ARE ASSUMED TO BE CORRECT, BEING INACCESSIBLE FOR CURRENT SURVEY.

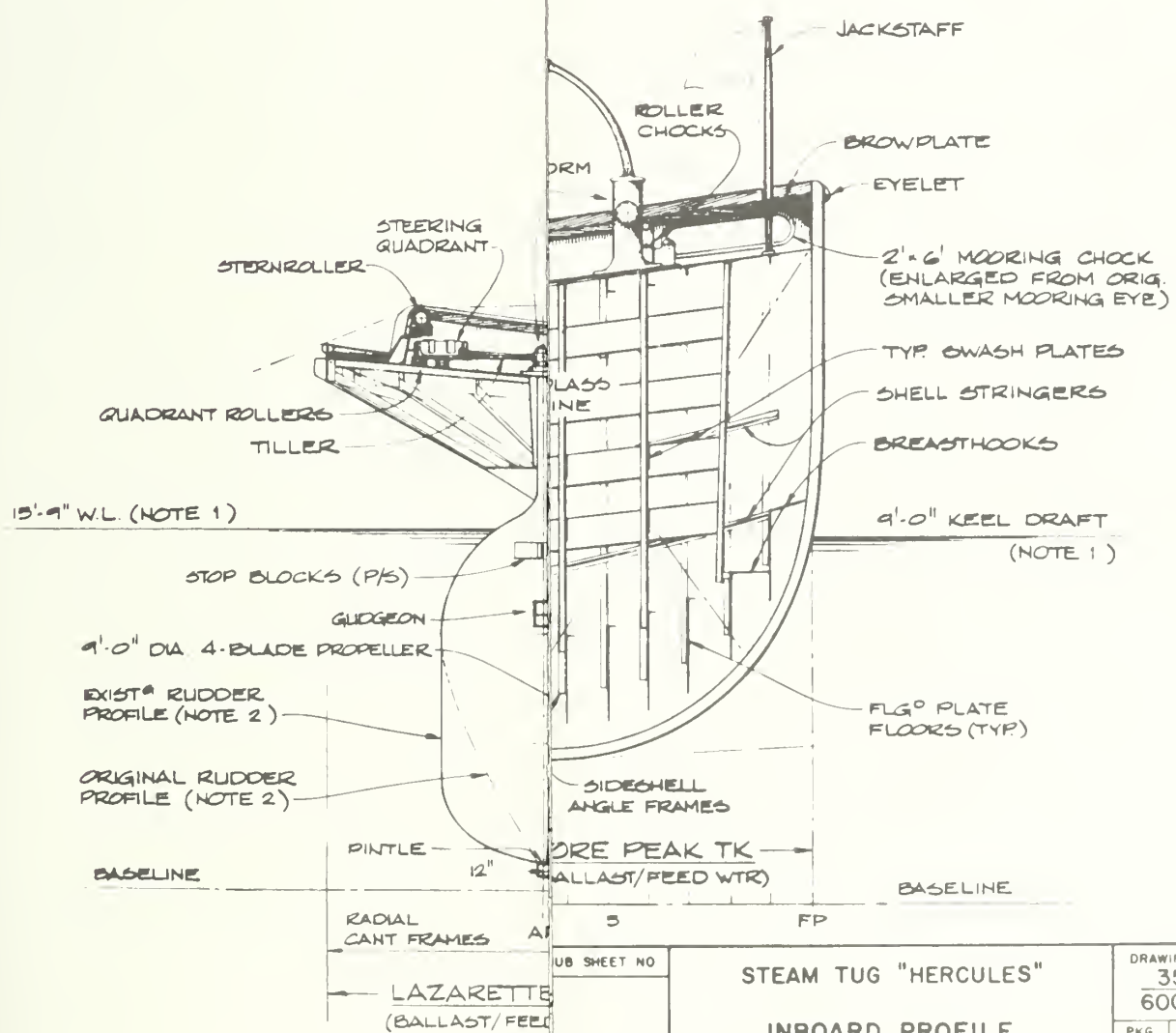
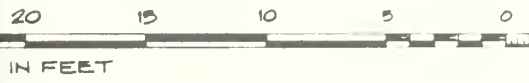

SUB SHEET NO	DRAWING NO	
	350	60000
STEAM TUG "HERCULES"		PKG NO
INBOARD PROFILE		SHEET
SAN FRANCISCO MARITIME NATIONAL HISTORICAL PARK		2
		OF 5

VESSEL IS CURRENTLY MOORED DOCKSIDE ON A 15'-9" BASELINE DRAFT (9'-0" KEEL DRAFT FWD) WITH MIDSHIP FUEL OIL TANKS P/S FILLED APPROXIMATELY 75% WITH FRESH WATER, AND LAZARETTE AND PEAK TANKS EMPTY. DESIGNED FULL LOAD WATERLINE IS ASSUMED TO BE IN THE AREA OF 16'-6".

RUDDER AREA WAS ENLARGED OVER ORIGINAL DESIGN IN 1941 (SEE BELOW) TO PROVIDE INCREASED MANEUVERABILITY FOR BAY TOWING CONDITIONS.

ALTHOUGH SKEG AND STERNFRAME PROFILE HAS BEEN FAIRLY WELL DOCUMENTED FROM PHOTOGRAPHS, THE TYPE OF CONSTRUCTION HAS NOT BEEN ACCESSIBLE FOR CURRENT SURVEY.

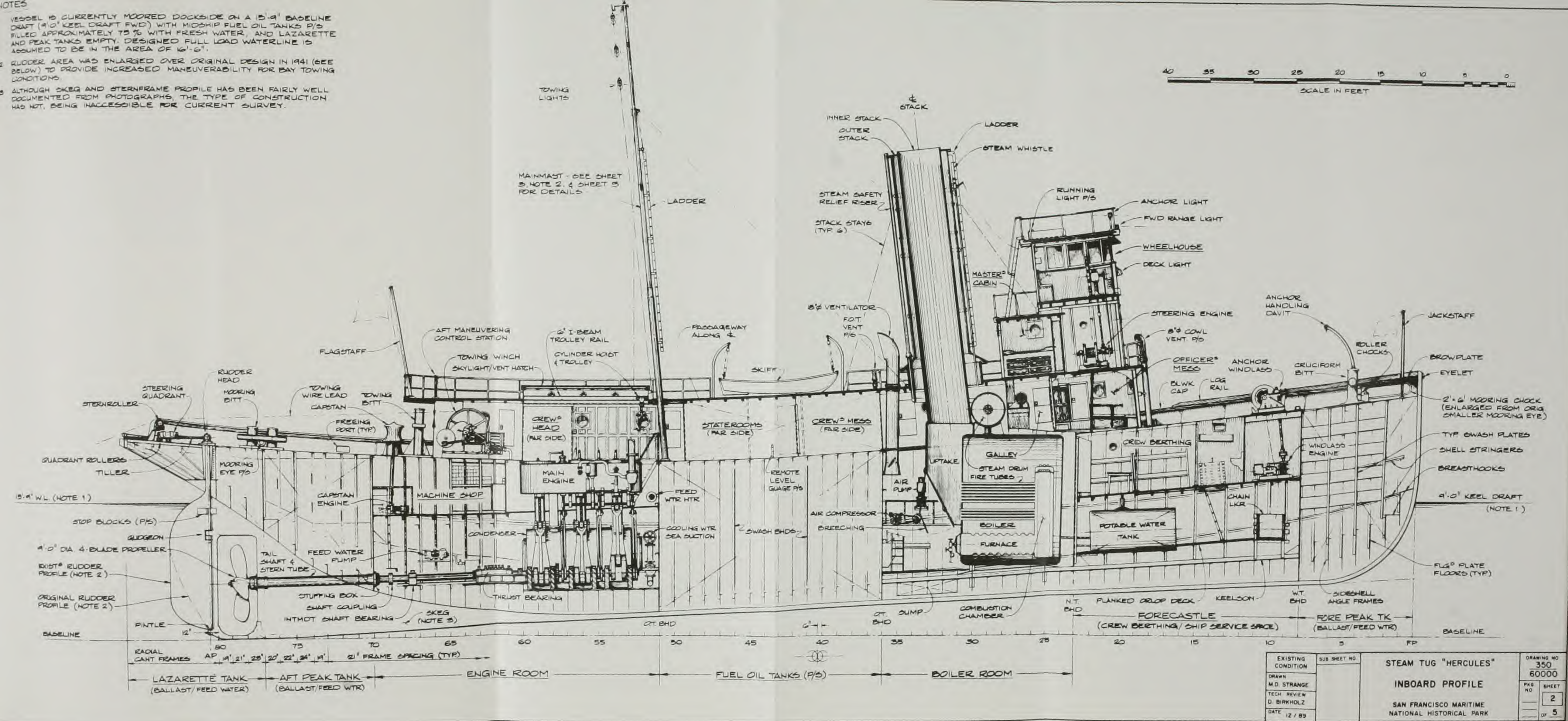
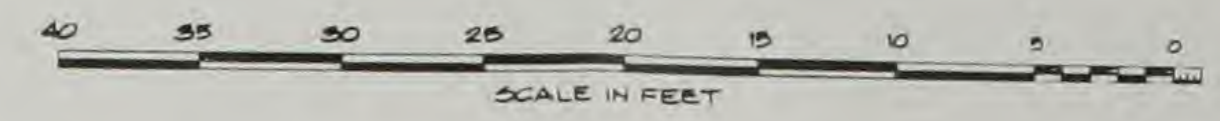

EXISTING CONDITION	SUB SHEET NO.	STEAM TUG "HERCULES"		DRAWING NO.
DRAWN M.D. STRANGE		INBOARD PROFILE		350
TECH REVIEW D. BIRKHOFF		SAN FRANCISCO MARITIME NATIONAL HISTORICAL PARK		60000
DATE 12 / 89		PKG NO.	SHEET	2
			OF	5

NOTES:

1. ORIGINAL WHEELHOUSE WAS BUILT APPROX DECK INSTEAD OF CURRENT ELEVATED POS
2. VESSEL WAS ORIGINALLY EQUIPPED WITH A W/ YARD & HEADSAILS (LOC'N SHOWN ON MAIN MAST DESIGN AS SHOWN IS NOT ORIGINAL)
3. WHILE ASSIGNED TO OCEAN SERVICE, TUG LIFEBOATS OF SIZE & CAP'Y SHOWN; 1 PORT OPPOSITE ONE ANOTHER. (PORT SIDE DAVIT SHOWN ON STBD). A WORKBOAT WAS KEPT OVER THE PORT LIFEBOAT.
4. STATEROOMS FR 41-49 PORT & FR 39-45 1/2 "CERTIFIED FOR 2 SEAMEN". HOWEVER, THESE BERTHS (W/ DRAWERS UNDER) & ARE BELIEVED BERTHING. VESSEL MANNING REQUIREMENTS GREATLY REDUCED WHEN TUG WAS TRANSFERRED OCEAN TO BAY TOWING SERVICE.
5. COMPARTMENT @ FR 36-41 PORT IS TAGGED "CREWS' MESS". HOWEVER, NO PERMANENT FIX OR CONFIRM THIS LABELLING. (SPACE IS CURRENTLY SHIP'S OFFICE DURING RESTORATION PROCESS)
6. HEAD LOCATED FR 57-60 PORT APPEARS TO SEE SHEET 4, NOTE 3 FOR ORIGINAL LOCATION
7. VESSEL UNDERWENT NUMEROUS CHANGES AS TO EQUIPMENT, ETC. CHECK SURVEY REPORT FOR

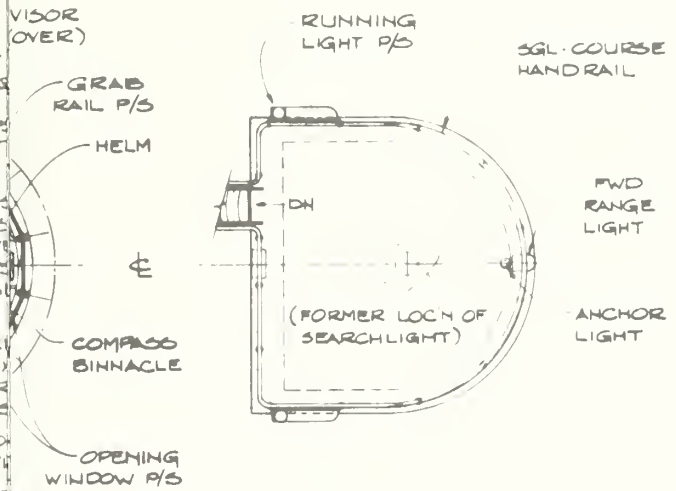

TOP OF WHEELHOUSE

DECK

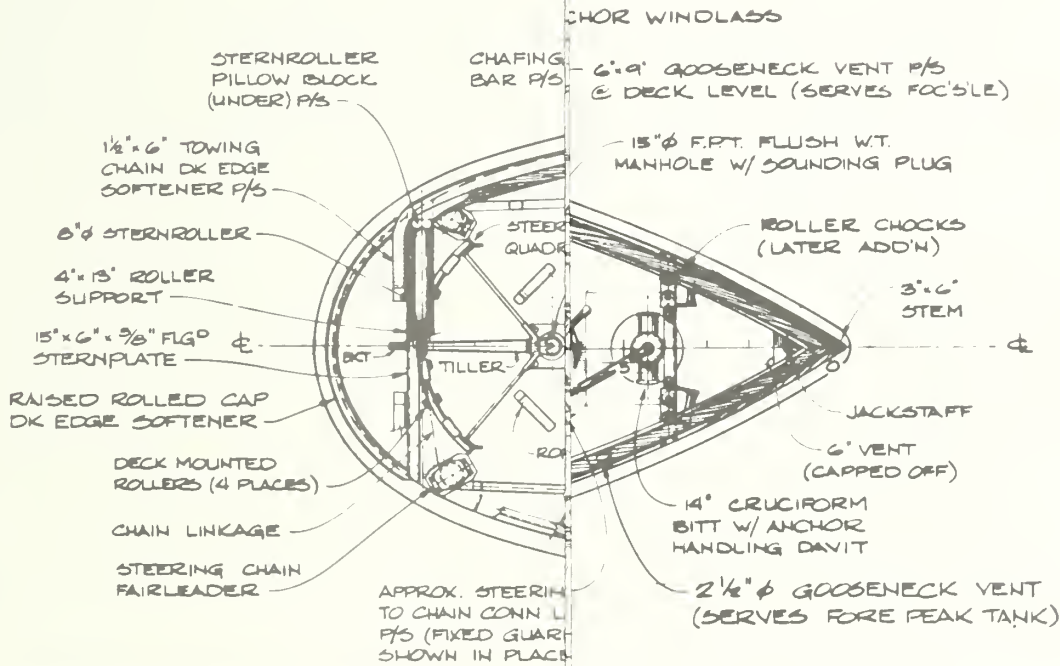

NOTE: STERNROLLER & BULWARK SHOWN CUT AWAY STBD TO EXPOSE DECK MOUNTED STEERING ASS'Y.

JOB SHEET NO

STEAM TUG "HERCULES"
ARRANGEMENT
MAIN DECK & ABOVE
SAN FRANCISCO MARITIME
NATIONAL HISTORICAL PARK

DRAWING NO
350
60000

PKG NO SHEET
3
OF 5

NOTES:

1. ORIGINAL WHEELHOUSE WAS BUILT APPROX. 42" ABOVE BOAT DECK INSTEAD OF CURRENT ELEVATED POSITION.
2. VESSEL WAS ORIGINALLY EQUIPPED WITH A FOREMAST COMPLETE W/ YARD & HEADSAILS (LOCN SHOWN ON MAIN DECK PLAN). MAIN-MAST DESIGN AS SHOWN IS NOT ORIGINAL. LOCN IS, HOWEVER.
3. WHILE ASSIGNED TO OCEAN SERVICE, TUG WAS EQUIPPED W/ 2 LIFEBOATS OF SIZE & CAP'Y SHOWN, 1 PORT & 1 STBD DIRECTLY OPPOSITE ONE ANOTHER. (PORT SIDE DAVITS WERE SIM. TO THOSE SHOWN ON STBD) A WORKBOAT WAS KEPT SWING IN THE DAVITS OVER THE PORT LIFEBOAT.
4. STATEROOMS FR 41-49 PORT & FR 39-45 & STBD ARE TAGGED "CERTIFIED FOR 2 SEAMEN". HOWEVER, THESE ROOMS HAVE SINGLE BERTHS (W/ DRAWERS UNDER) & ARE BELIEVED TO BE OFFICER BERTHING. VESSEL MANNING REQUIREMENTS WERE MOST LIKELY GREATLY REDUCED WHEN TUG WAS TRANSFERRED FROM FULL OCEAN TO BAY TOWING SERVICE.
5. COMPARTMENT 8 FR 36-41 PORT IS TAGGED "CERTIFIED FOR CREWS MESS". HOWEVER, NO PERMANENT FIXTURES EXIST TO DENY OR CONFIRM THIS LABELLING. (SPACE IS CURRENTLY BEING USED AS SUP'S OFFICE DURING RESTORATION PROCESS)
6. HEAD LOCATED FR 57-60 PORT APPEARS TO BE A LATER ADDITION. SEE SHEET 4, NOTE 3 FOR ORIGINAL LOCATION.
7. VESSEL UNDERWENT NUMEROUS CHANGES ABOVE DECK RE: WIRELESS EQUIPMENT, ETC. CHECK SURVEY REPORT FOR SPECIFICS.

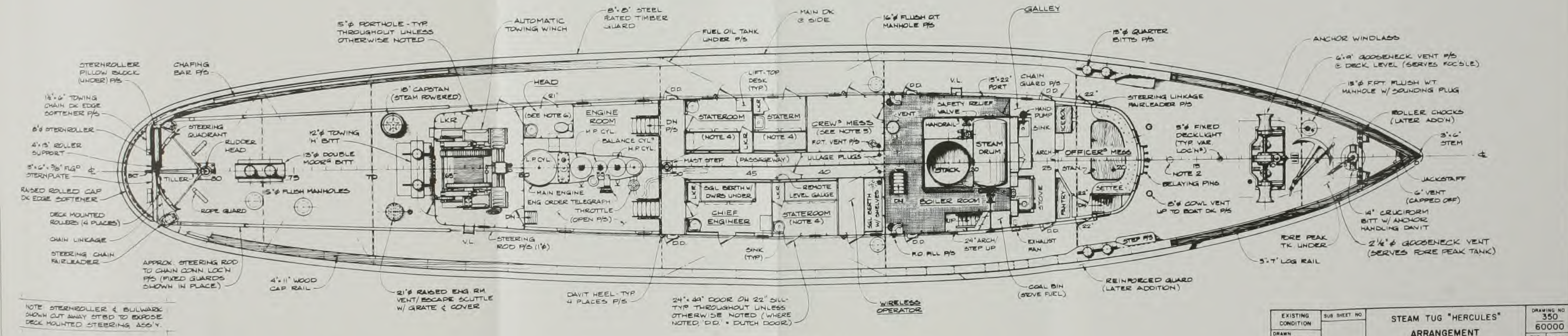
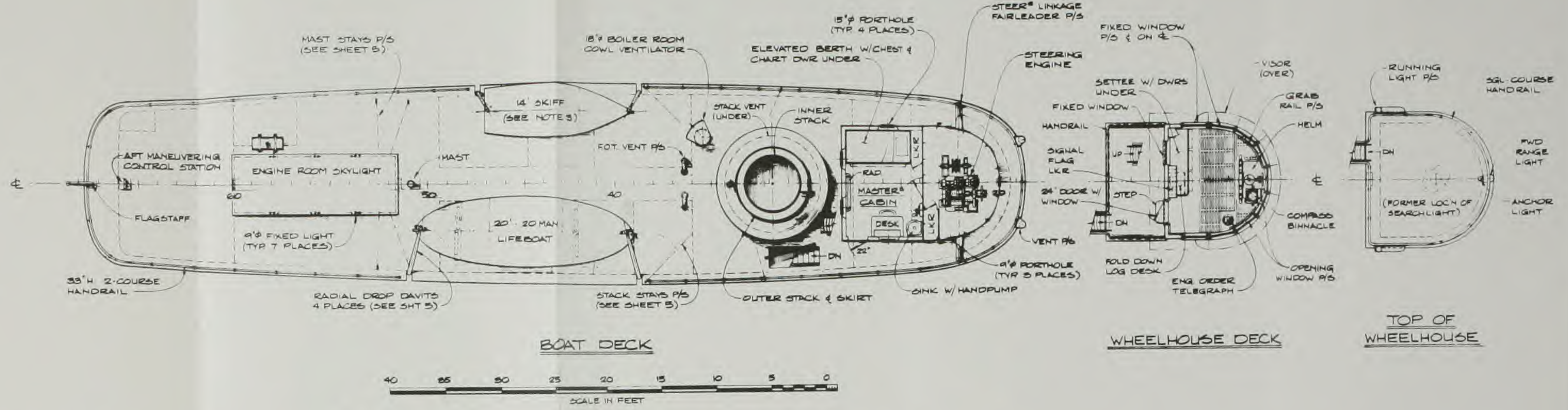

EXISTING CONDITION	SUB SHEET NO.	STEAM TUG "HERCULES" ARRANGEMENT MAIN DECK & ABOVE SAN FRANCISCO MARITIME NATIONAL HISTORICAL PARK	DRAWING NO. 350
DRAWN M.D. STRANGE			PKG. NO. SHEET 3
TECH REVIEW D. BIRKHOFF			OF 5
DATE 12/89			

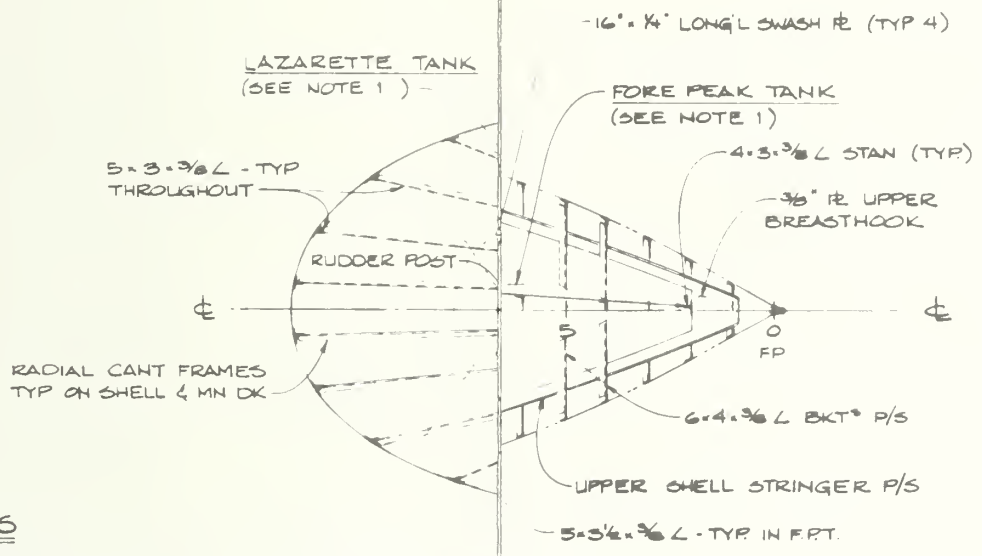

NOTES

1. FORE PEAK, AFT PEAK, & LAZARETTE TANKS WERE USED FOR BALLAST OR BOILER FEED W STORES (TACKLE, ETC.)
2. FORECASTLE FLAT IS A NON-WATERTIGHT DECK RESERVED FOR CREW BERTHING. CURRENT AREA APPEARS TO BE HISTORICALLY INACCURATE AS BERTHING REQUIREMENTS WOULD HAVE BEEN 8' CURRENT WOOD PARTITIONED STORES AREA PROBABLY WOULD HAVE PROVIDED ADD'L BERTHING ALONG WITH 3-TIER BUNKS.
3. MACHINE SHOP FLAT IS A NON-WATERTIGHT DECK HISTORICAL PURPOSE SEEMS TO HAVE BEEN USED FOR THE ENGINEERING CREW. STORAGE BINS AND P/S RESEMBLE 3-TIER BERTHS. STORAGE AREA PORT IS TAGGED 'CERTIFIED FOR CREWS HERE'.
4. A PHOTOGRAPH WAS LOCATED SHOWING THAT DONKEY BOILER EXISTED IN THE CURRENT PORT OIL HEATER LOCATION. ORIGINAL HTR LOC'N UNKN.
5. ALL MACHINERY IS STEAM-DRIVEN UNLESS NOTED OTHERWISE.
6. SEE SHEET 5 FOR STRUCTURAL INFORMATION CALLED OUT ON THIS PLAN.

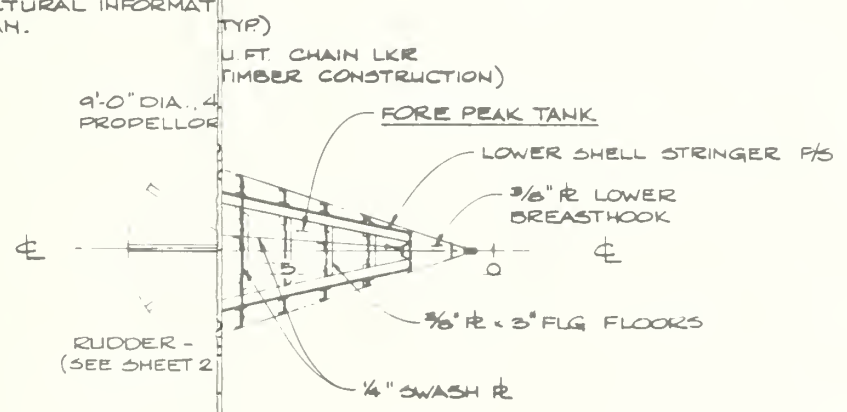

SUB SHEET NO	STEAM TUG "HERCULES"	DRAWING NO	
		350	60000
	HOLD ARRANGEMENT	PKG NO	SHEET
			4
	SAN FRANCISCO MARITIME NATIONAL HISTORICAL PARK	OF 5	

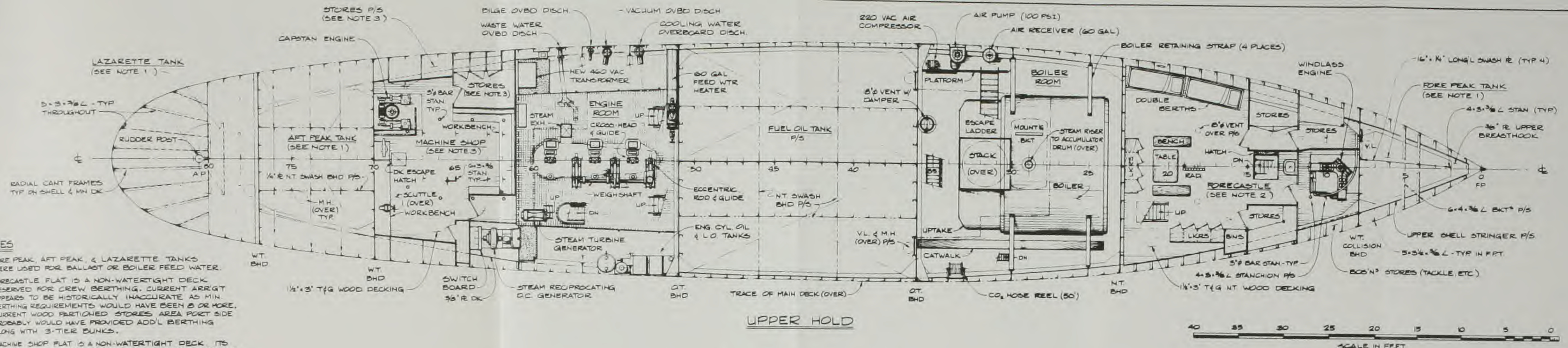

UPPER HOLD

- NOTES**
1. FORE PEAK, AFT PEAK, & LAZARETTE TANKS WERE USED FOR BALLAST OR BOILER FEED WATER.
 2. FORECASTLE FLAT IS A NON-WATERTIGHT DECK RESERVED FOR CREW BERTHING. CURRENT ARR'GT APPEARS TO BE HISTORICALLY INACCURATE AS MIN. BERTHING REQUIREMENTS WOULD HAVE BEEN 3 OR MORE. CURRENT WOOD PARTITIONED STORES AREA PORT SIDE PROBABLY WOULD HAVE PROVIDED ADD'L BERTHING ALONG WITH 3-TIER BUNKS.
 3. MACHINE SHOP FLAT IS A NON-WATERTIGHT DECK. ITS HISTORICAL PURPOSE SEEMS TO HAVE BEEN BERTHING FOR THE ENGINEERING CREW. STORAGE BINS AFT FR 65 TO RESEMBLE 3-TIER BERTHS. STORAGE AREA FR 61-65 PORT IS TAGGED 'CERTIFIED FOR CREWS HEAD'.
 4. A PHOTOGRAPH WAS LOCATED SHOWING THAT A SMALL DONKEY BOILER EXISTED IN THE CURRENT FUEL OIL HEATER LOCATION. ORIGINAL HTR LOCN UNKNOWN.
 5. ALL MACHINERY IS STEAM-DRIVEN UNLESS NOTED OTHERWISE.
 6. SEE SHEET 5 FOR STRUCTURAL INFORMATION NOT CALLED OUT ON THIS PLAN.

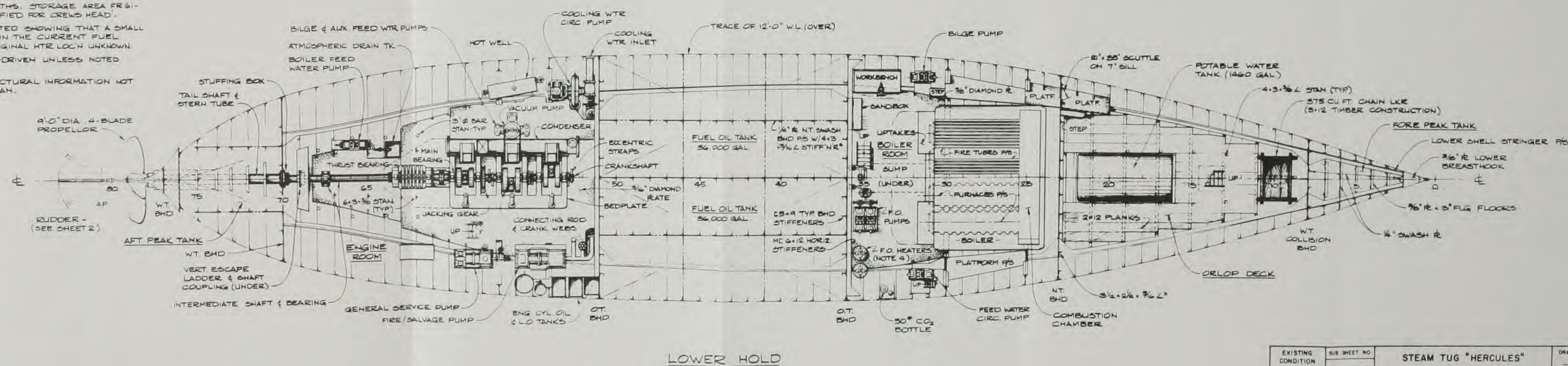

LOWER HOLD

EXISTING CONDITION	SUB SHEET NO.	STEAM TUG "HERCULES"	DRAWING NO.
DRAWN M.D. STRANGE			350
TECH REVIEW D. BIRKHOLZ		HOLD ARRANGEMENT	60000
DATE 12 / 89		SAN FRANCISCO MARITIME NATIONAL HISTORICAL PARK	PKG. NO. SHEET 4 OF 5

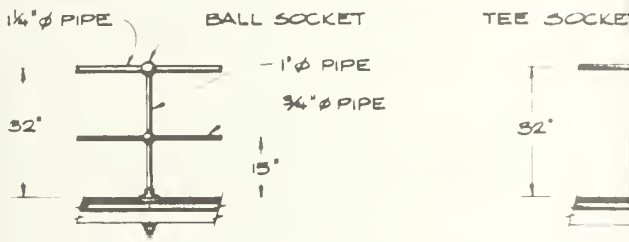

HANDRAIL DET.
BOAT DECK

2 1/2 x 1/4 FB = 3/4" RUNG
LADDER LOCATED PORT
AMIDSHIPS & STBD AFT
1/4" R N.W.T DOOR (TYP)

1" FORGED BLWK STAYS ON
APPROX. 5'-4" CENTERS

4' x 11" OAK CAP RAIL
ATOP 2 1/2 x 2 1/2 x 3/8 L

1/4" R BULWARK
27" 3/2 x 2 1/2 x 3/16 L
RETAINER (TYP)

5' x 5' TIMBER
UPPER GUARD
W/ 1/4" CHAFE BAR

1/2" R SHEER
(F) STRAKE

5' x 5' TIMBER
LOWER GUARD
ENCASED IN 1/4" R

3/8" R 'E' STRAKE

6 x 6 x 3/8 T HOLD
STRINGER ATTACHED
TO DOUBLE 4 x 3 L
CLIPS @ EACH FR.

5 x 3/8" F.B. LINER
(TYP @ EACH FRAME)

3/8" R 'D' STRAKE

3 x 3 x 3/8 DOUBLE L
BOUNDARY @ BHDS

6 x 6 x 3/8 T BILGE
STRINGER ATTACHED
TO DOUBLE 4 x 3 L
CLIPS AT EVERY FRAME

3/8" R 'C' STRAKE

7" T BILGE KEEL

'B' STRAKE

'A' STRAKE

CEMENT

(VARIE

BOILER

FURNACE

AIR REGISTER

BOILER

FEED WATER

CIRC. PUMP

HEAD

SEE NOTE 1



COMPOSITE STRUCTURE

SECTION LOOKING AT
A TYPICAL TRANSVERSE

SHOWN IN COMPOSITE SECTION INTERNALLY BELOW
LINE & EXTERNALLY BELOW EXIST'G 15'-9" WATERLINE
OWN UNDER CURRENT SURVEY. ASSUMPTIONS HAVE
MADE WHICH CLOSELY PARALLEL EXIST'G WRITTEN &
GRAPHIC INFORMATION, & ARE DRAWN AS SUCH. FURTHER
INFORMATION WILL REQUIRE OUT-OF-WATER SURVEY.

MAIN DECK ANGLES ARE OCCASIONALLY SUPPLANTED
BY CHANNELS IN WAY OF HEAVY DECK EQUIPMENT. 3'-2"
AT DECK ANGLES UNDER THE PILOT HOUSE HAVE BEEN
REPLACED BY 6'-3" CHANNELS TO SUPPORT THE STEERING
WHEELHOUSE ABOVE.

HANDRAIL DET.

WHEELHOUSE

HEADS 51 & 56 ARE OF OILTIGHT (O.T.) CONSTRUCTION
DOUBLE & TRIPLE RIVETTED SEAMS WITH
CAULKING). BULKHEADS 8, 70, & 77 ARE OF WATER-
TIGHT CONSTRUCTION (MEDIUM WEIGHT RATE, DOUBLE
RIVETTED & CAULKED). BULKHEAD 23 IS NON-WATERTIGHT
TOPPING APPROXIMATELY 1/4" SHORT OF THE BOTTOM
PLATE. ALL HEADS ARE OF CLINKER-TYPE CONSTRUCTION.

BLOCKING GUARD RUNS FULL PERIMETER AT MAIN DECK
LEVEL. LOWER GUARD RUNS APPROXIMATELY 4 FEET
UPPER GUARD BETWEEN FRAMES 14 AND 51 PORT
BOARD. IN ADDITION, DURING HER TENURE
CARRYING RAILCAR BARGES, THE TUG'S UPPER
GUARD HAD BEEN REINFORCED BETWEEN FRAMES
32, STARBOARD ONLY, BY INCREASING THE
STRAKE OF THE ORIGINAL GUARD FROM 8" TO 16".

PLATING IS OF "IN AND OUT" TYPE CONSTRUCTION,
APPROXIMATELY 36" AVERAGE STRAKE WIDTH.

SEE COAMING

3 x 2 1/2 x 3/16

24" TO 36"

6' x 6" @ HSE

AFT END TO

2 1/2 x 2 1/2 x 1/4

APPROX 30"

3 x 3 x 3/8 L

BOUNDARY @

WIRE STAY
CABLE (TYP. 6)

1/4" R
PLATE

MAN CONTROL VALVE

STEAM BOILER ROOM BHD @ FR 23

STEAM BOILER RETAINING STRAPS #5

CATWALK ACCESS TO BOILER
GAUGES & SAMPLER COCKS

BREACHING DOORS REMOVED STBD
TO REVEAL FIRE TUBE ARR'G'T

BOILER FURNACE AIR REGISTER

BOILER FEED WATER CIRC. PUMP

HEAD

SHEET NO

STEAM TUG "HERCULES"
MIDSHIP & MACHINERY
SECTIONS

SAN FRANCISCO MARITIME
NATIONAL HISTORICAL PARK

DRAWING NO
350
60000

PKG NO SHEET
5
OF 5

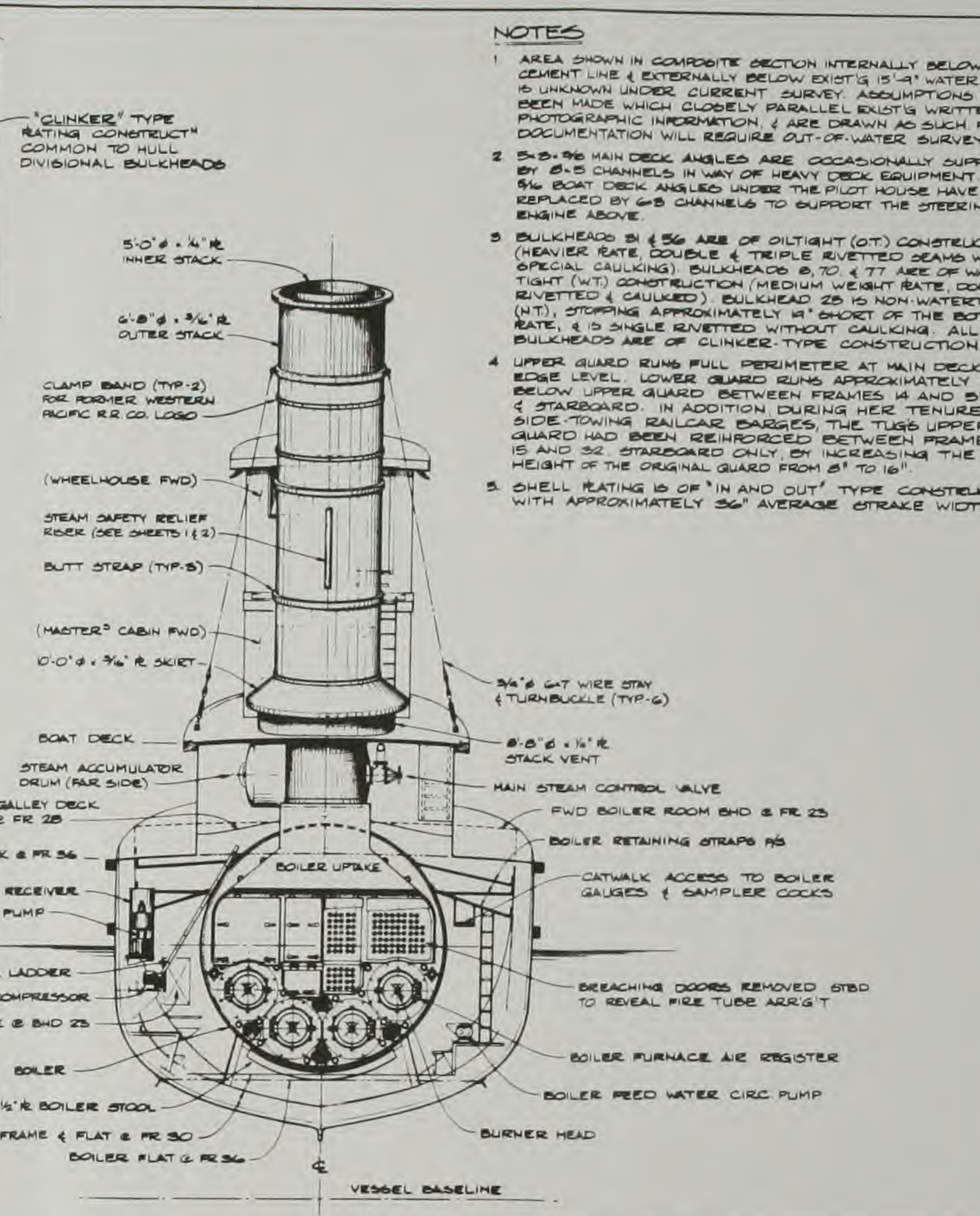
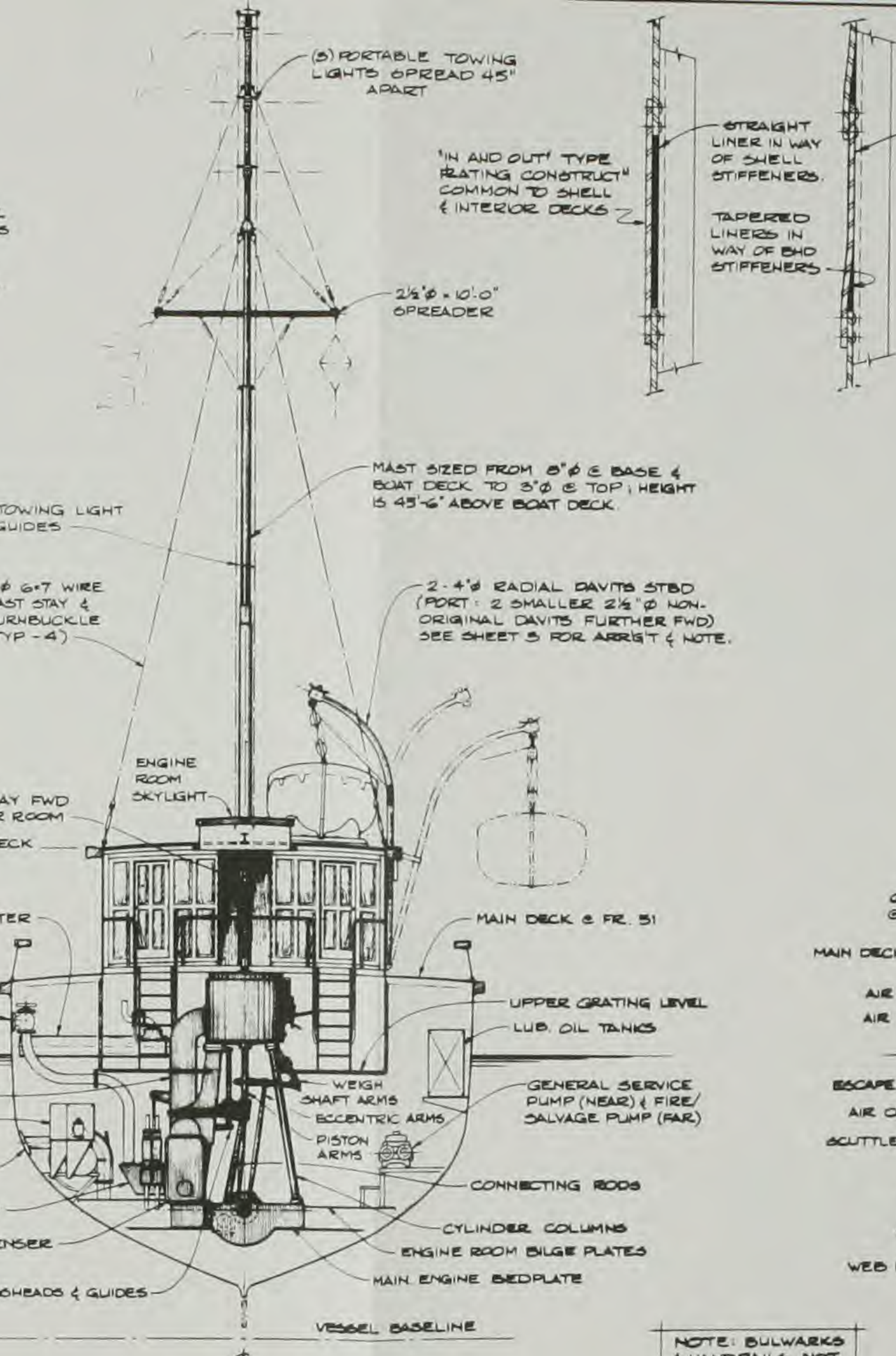
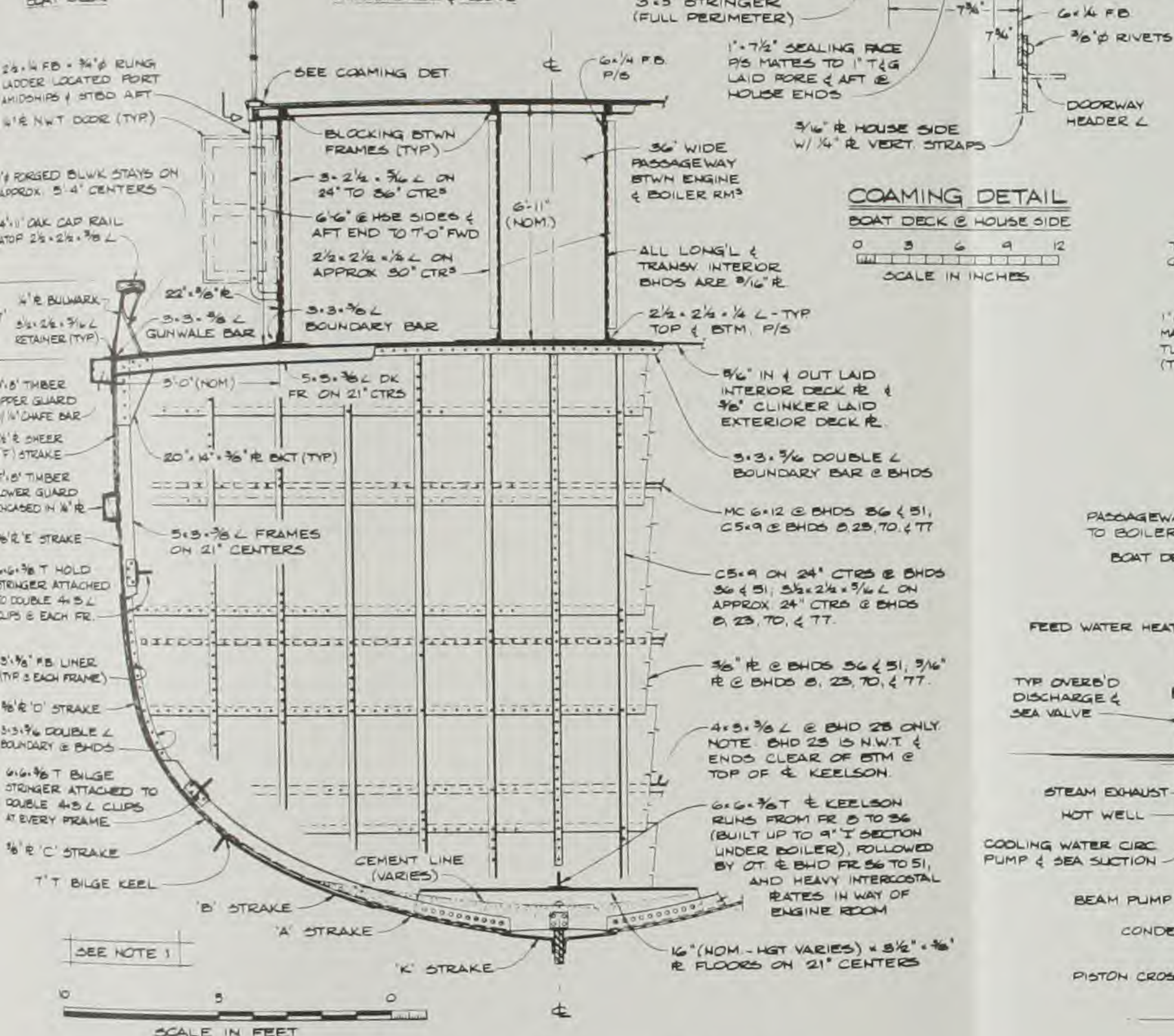
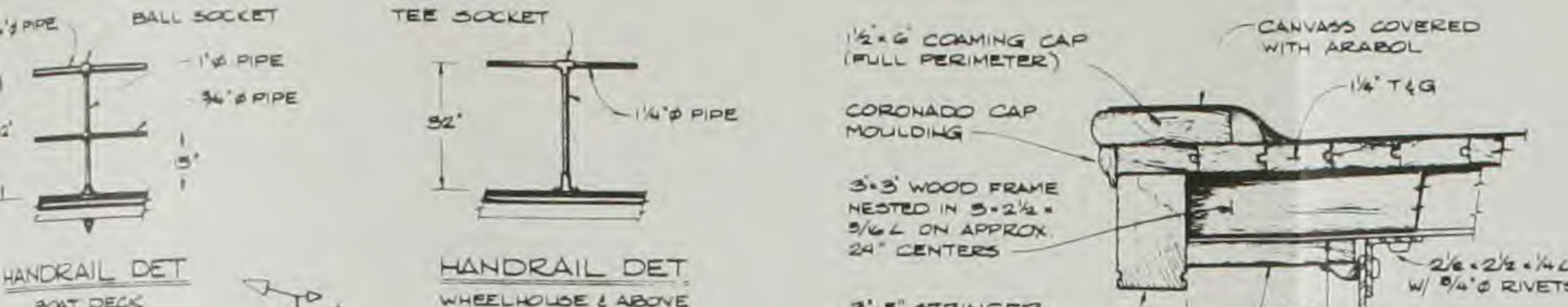

- NOTES**
- 1 AREA SHOWN IN COMPOSITE SECTION INTERNALLY BELOW CEMENT LINE & EXTERNALLY BELOW EXIST'G 15'-9" WATERLINE IS UNKNOWN UNDER CURRENT SURVEY. ASSUMPTIONS HAVE BEEN MADE WHICH CLOSELY PARALLEL EXIST'G WRITTEN & PHOTOGRAPHIC INFORMATION, & ARE DRAWN AS SUCH. FURTHER DOCUMENTATION WILL REQUIRE OUT-OF-WATER SURVEY.
 - 2 5'-3" x 3/8" MAIN DECK ANGLES ARE OCCASIONALLY SUPPLANTED BY 3'-5" CHANNELS IN WAY OF HEAVY DECK EQUIPMENT. 3'-2" x 3/8" BOAT DECK ANGLES UNDER THE PILOT HOUSE HAVE BEEN REPLACED BY 6'-3" CHANNELS TO SUPPORT THE STEERING ENGINE ABOVE.
 - 3 BULKHEADS 21 & 26 ARE OF OILTIGHT (O.T.) CONSTRUCTION (HEAVIER RATE, DOUBLE & TRIPLE RIVETTED DEAMS WITH SPECIAL CAULKING). BULKHEADS 20, 70, & 77 ARE OF WATER-TIGHT (W.T.) CONSTRUCTION (MEDIUM WEIGHT RATE, DOUBLE RIVETTED & CAULKED). BULKHEAD 25 IS NON-WATERTIGHT (N.T.), STOPPING APPROXIMATELY 14" SHORT OF THE BOTTOM RATE, & IS SINGLE RIVETTED WITHOUT CAULKING. ALL BULKHEADS ARE OF CLINKER-TYPE CONSTRUCTION.
 - 4 UPPER GUARD RUNGS FULL PERIMETER AT MAIN DECK EDGE LEVEL. LOWER GUARD RUNGS APPROXIMATELY 4 FEET BELOW UPPER GUARD BETWEEN FRAMES 14 AND 51 PORT & STARBOARD. IN ADDITION DURING HER TENURE SIDE-TOWING RAILCAR BARGES, THE TUG'S UPPER GUARD HAD BEEN REINFORCED BETWEEN FRAMES 15 AND 32. STARBOARD ONLY, BY INCREASING THE HEIGHT OF THE ORIGINAL GUARD FROM 8" TO 16".
 - 5 SHELL PLATING IS OF 'IN AND OUT' TYPE CONSTRUCTION, WITH APPROXIMATELY 36" AVERAGE STRAKE WIDTH.

COMPOSITE STRUCTURAL SECTION AMIDSHIPS

SECTION LOOKING AT & PAST A TYPICAL FRAME TO A TYPICAL TRANSVERSE BULKHEAD.

ENGINE ROOM

SECTION LOOKING FWD TO FRAME 51

BOILER ROOM

SECTION @ FRAME 36 LOOKING FWD

EXISTING CONDITION	SUB SHEET NO.	DRAWING NO. 350 60000
DRAWN M.D. STRANGE		
TECH REVIEW D. BIRKHOFF		PAGE NO. 5
DATE 12 / 89		OF 5

STEAM TUG "HERCULES"
MIDSHIP & MACHINERY SECTIONS
SAN FRANCISCO MARITIME NATIONAL HISTORICAL PARK

2-6. Analysis of Treatment Alternatives

2-6.1. Previous Planning

To date, Park planning for HERCULES has been limited, yet a general treatment plan has gradually evolved. In 1980, the General Management Plan for the Golden Gate National Recreation Area spoke in general terms of preservation of HERCULES, along with the rest of the historic fleet (National Park Service 1980). Later, the Interpretive Prospectus for the National Maritime Museum stressed the need to interpret HERCULES: "The vessel must be opened to the public" (National Maritime Museum 1987). In addition, the Prospectus stated: "A museum goal is to restore HERCULES to operating condition. She might become a working vessel for the museum, and could definitely function as an excursion vessel and as a roving ambassador for the museum."

A year later, the Cultural Resource Management Plan for the Fleet of Historic Ships expanded on this theme and presented a general outline for restoring HERCULES to operating condition (Tri-Coastal Marine 1987). Thus far, there has been no formal assessment of the various treatment alternatives.

2-6.2. Alternatives

The following discussion covers treatment alternatives ranging from stabilization to full operation. Treatments such as de-accession and disposal are not discussed and are not considered acceptable given the intact state of the vessel and her regional and national significance.

2-6.2.1. Stabilization

Stabilization would preserve HERCULES in her present state in anticipation of future preservation or restoration. Steps would include preservation of the hull, sealing of main deck and top of deck house, and lay-up of all machinery and equipment. Hull preservation would require drydocking for coating of the hull exterior and repair of dangerously thin hull plating. An impressed-current cathodic protection system would be installed and maintained. The lay-up of machinery would be carried out in the manner the U.S. Navy uses to "mothball" their deactivated vessels—by applying heavy preservative coatings to the interior and exterior of all items. A dry environment would be maintained inside the vessel by sealing all openings and by keeping lights or heaters

operating to dispel moisture. A bilge, fire, and security alarm system would remain activated.

Advantages:

- The sole advantage to this treatment is its minimal cost.

Disadvantages:

- Stabilization does not provide for meaningful interpretation. At best, the public could be allowed access to the main deck and boat deck.
- Another possible disadvantage is somewhat intangible, but nonetheless important: the loss of valuable technical knowledge essential to the restoration, operation, and maintenance of a marine steam plant. This knowledge is presently in the hands of a few individuals, such as engineers and oilers, who have first-hand experience through years of service in steam vessels. These individuals, many of whom are volunteers, are already well into retirement age and cannot be expected to be active for more than a few more years. If restoration of HERCULES is deferred for an extended period, the opportunity to transfer this valuable knowledge to a younger generation may well be lost.

2-6.2.2. Restoration for Static Exhibit

Static exhibit would be limited to display of HERCULES in a pier-side setting. The public would be given access to the vessel via a floating dock or by gangway from the Hyde Street Pier. With some modifications for safety, visitors could be given partial access to most of the interesting compartments, including boiler room and engine room.

The treatment of the hull and machinery would be limited to preservation. The hull would need to undergo work similar to that required for stabilization, including drydocking and hull repairs. Treatment of machinery would involve stabilization of interior workings, and preservation of exterior surfaces with use of anti-corrosive and decorative coatings. None of the machinery would be mechanically restored or made operational. The superstructure and interior spaces would be restored to the historic configuration of either the oceangoing or harbor tug period.

Advantages:

- Getting the public aboard HERCULES would increase the interpretive scope of the Park. Public access with onboard interpretation should be considered a minimum goal for treatment.

Disadvantages:

- Without restoration of at least some of the machinery to operating condition, interpretive potential will be lost, along with the public interest that would be generated by an active display.
- Volunteer interest would likely fall off, thus increasing the burden on staff.
- The opportunity for the transfer of knowledge in the operation of steam machinery would be lost.

2-6.2.3. Restoration for Limited Operation

This alternative would involve restoring HERCULES to operating condition for interpretation at the pier and for occasional excursions on the Bay. The entire propulsion system, including boiler, engine, and auxiliary equipment, would undergo full restoration and would be maintained in operating condition. Drydocking work would include overhaul of sea valves, rudder, shaft, and stern bearing; hull coating and any necessary hull repairs. Restoration of interior spaces and modifications for public access would be undertaken as in the Static Exhibit alternative.

HERCULES would be steamed occasionally, much as the Liberty Ship JEREMIAH O'BRIEN is, but would carry only staff, volunteers, and nonpaying guests.

Advantages:

- This alternative would greatly increase the interpretive value of HERCULES by allowing operational display of portions of the machinery. The visiting public would thus be afforded a greater understanding of the steam tug, and steam propulsion in general.
- Volunteer interest could be better maintained and would in turn benefit preservation of the vessel over the long term.
- Steaming HERCULES on the Bay, even on a limited basis, would provide greater visibility for the Park.

Disadvantages:

- There would be an increased level of risk of injury to vessel and personnel in activating the machinery and steaming HERCULES. Risk can be reduced to a level that the U.S. Coast Guard and the commercial marine industry considers acceptable by adopting established standards for operation. Nevertheless, risk would be greater than for static exhibit.
- Some alterations would be necessary to safely steam the vessel. Although minor, these alterations would have an impact on historic integrity.

2-6.2.4. Operation as an Excursion Vessel

Under this plan, HERCULES would be placed in service as an excursion vessel, carrying paying passengers on scheduled day-trips or under charter. While at the pier, she would be open to the public. In addition to the requirements for achieving limited operation, this alternative would necessitate modifications for safety of passengers.

Advantages:

- This alternative would have all of the benefits of the Limited Operation alternative including an increase in interpretive value, heightened volunteer interest, and greater visibility for the Park.
- The Park could earn revenue from operation, although it might not be sufficient to cover the cost of crew and fuel.

Disadvantages:

- The major disadvantage is the compromise to historic integrity that would be necessary to convert HERCULES to an excursion vessel. As a vessel of over 100 gross tons, HERCULES would fall under U.S. Coast Guard regulations known as Subchapter H (Department of Transportation 1987). These regulations govern the design, construction, and operation of large passenger vessels. It would be extremely difficult for a steam tug built in 1907 to meet these regulations without major modifications. Although it is possible to operate a government-owned vessel without Coast Guard certification, concerns over passenger safety would warrant adherence to most of the requirements.

- Frequent operation would increase the risk of injury to the vessel and personnel.
- A significant financial burden could be placed on the Park. Without further analysis, it will be difficult to determine the initial and long-term costs of this alternative. Unknown factors include the total cost of conversion to an excursion vessel, the cost of operation, and the realistic potential for earning revenue. The costs associated with operating a large vessel in commercial service are usually considerable. Even taking into account other expected benefits, such as increased volunteer support, this alternative may well be an expensive proposition.

2-6.3. Conclusions

The minimum goal for treatment of HERCULES should be achieving public access with onboard interpretation. To do less would under-utilize the resource. On the other hand, operating HERCULES as an excursion vessel is not considered a practical nor responsible treatment as the benefits of operation are outweighed by the impact to historic integrity and the potentially high cost of modification and operation.

The most expansive treatment that can be undertaken without undue compromise to historic integrity is restoration for limited operation. The public and volunteer interest that would be generated would benefit the Park and help to ensure the long-term preservation of HERCULES, as well as the knowledge and skills necessary to maintain her. To protect the resource, any operation, including activating steam equipment while at the dock, should be undertaken within established guidelines.

It is recommended that one era within the period of greatest historic significance (1907-1924) be selected as the focus of restoration, and that long-term planning include steps necessary to return HERCULES to her original oceangoing configuration. Such work will involve reconstruction of missing elements, and removal or reversal of later additions which are incompatible with the vessel's configuration during the selected period. These steps and their justification are covered in further detail in the following section.

2-7. Proposed Treatment

2-7.1. Overview of Treatment

The recommended treatment for HERCULES is restoration as a floating exhibit, with public access and a degree of operational capability. The target period for restoration is 1907 to 1924—her years of service as an oceangoing tug. HERCULES' historic color scheme and furnishings should be those of the period of ownership by the Merchants and Shipowners Tug Boat Company ("Red Stack").

Public access to HERCULES would be achieved with development of a permanent berth at the Hyde Street Pier. Interior spaces should be restored, and modifications made to allow safe visitor access to all major compartments of the vessel (see 2-6.3. "Interpretation").

Operational capability should begin with restoration of the boiler, main engine, and auxiliary machinery, thereby allowing active interpretation of these elements while at the dock. Restoration to steaming condition would follow. HERCULES would ultimately be capable of occasional excursions on San Francisco Bay, and could make port visits to other towns in the Bay and Delta.

Application of the recommended treatment to the various elements of the vessel will involve a combination of preservation, restoration, reconstruction, and limited modification.

2-7.1.1. Preservation

The following elements would be preserved through limited repair, and by coating or treating fabric to prevent further deterioration due to corrosion or rot.

- hull interior and exterior
- main deck (followed by full restoration)
- engine
- most auxiliary steam equipment, including pumps, generators, valves, and piping

2-7.1.2. Restoration

Elements which have suffered extensive damage would be restored through in-kind replacement of deteriorated existing fabric.

Modifications inconsistent with the chosen historic period, would be restored to their original configuration.

- deckhouse
- boat deck
- boiler and some auxiliary steam equipment, such as condenser and main circulating pump
- arrangements and furnishings in interior compartments of deckhouse, saloon, galley, and fore-castle
- windlass
- lifeboat

2-7.1.3. Reconstruction

Elements which are too deteriorated to be restored or effectively preserved on board would be removed to protected storage and replaced by functioning replicas. Missing elements which are important to historic integrity would be replaced with accurate reproductions. Elements which have been modified to the extent they no longer reflect the historic character of the vessel would be reconstructed in their original form.

- pilothouse
- fore and main masts
- donkey boiler
- running lights and boxes
- hot well tank
- atmospheric drain tank
- skiff

2-7.1.4. Modification

Where necessary, modifications would be made to facilitate public access, interpretation, and to ensure the safety of the vessel and historic machinery. These include:

- fuel tank
- boiler room viewing platform
- boat deck railings
- electrical system
- oily-water separator and holding tank
- emergency diesel generator
- cathodic protection system
- fire, bilge, and security alarm system

2-7.2. Enumeration of Steps

The major steps necessary to achieve the recommended treatment are described in this section, along with the suggested procedures for completing them. Where steps involve major intervention, or alteration of historic fabric, the rationale is given. In all cases, the guidelines in the Secretary of the Interior's "Standards for Historic Vessel Preservation Projects" should be followed. The following steps are listed in a general order of priority that first addresses safety and preservation concerns, followed by the development of public access and interpretation, and finally, completion of restoration to the selected historic period. A recommended sequence and schedule for implementing the treatment is outlined in section 2-7.

Cost estimates are given for general budgeting and planning purposes. A further definition of some steps will be required before cost can be estimated with accuracy. This can be achieved as research is completed, and plans and specifications are developed.

2-7.2.1. Safety Upgrades

A prerequisite for implementing the treatment is a safe environment for those working aboard the vessel. It is also important to insure that the work does not compromise the safety of the vessel or the surrounding environment. Much has been done to improve safety aboard HERCULES since her move to the restoration berth at Lower Fort Mason. The following additional measures are recommended to complete this work:

1. Repair Upper Engine Room Grating

The heavy iron grating forming the upper engine room flat has lost most of its support due to wastage of hanger brackets and bolted attachments. Restoration of these supports is recommended before the flat is subjected to further loading.

The majority of the deck plates in the boiler room and lower engine room have been repaired and are now secure. A few deck plates will require additional work, particularly those at the aft end of the engine room. 2. Install Ground-fault Circuit Interrupters (GFCI's):

Treatment calls for installation of a properly designed marine-grade electrical system to replace the system now in use. Until this system can be installed, the use of GFCI's, devices which greatly reduce the chance of elec-

trocution, is recommended on all shipboard electrical circuits being used in wet or damp areas of the vessel. If these devices cannot be installed in existing circuits, portable devices are available which can be plugged into receptacles for use with extension cords, drop lights, and power tools.

3. Develop System for Handling Oily Waste

Oily waste is invariably generated in the course of overhauling and operating steam machinery. To prevent this waste from becoming a fire hazard or pollutant, a waste handling system should be developed. Present practices are generally adequate for handling solid waste, such as oil-soaked rags, but there is no provision for dealing with oily bilge water. A temporary means of containing, treating, or disposing of contaminated bilge water is needed until a permanent oily-water separation system can be installed.

4. Install Fire-suppression System in Boiler Room

The presence of fuel oil and heat in the boiler room — both necessary for firing the boiler—will increase the possibility of accidental fire in this compartment. A fire-suppression system (preferably a type approved by the U.S. Coast Guard) will be needed to protect the vessel when the boiler is operated. Installation of this system is considered a high priority. Additionally, sealing off the bulkhead at the forward end of the boiler room will increase the effectiveness of the fire-suppression system and prevent the possibility of fire spreading to the fore-castle area. This work is recommended for the drydocking period.

5. Emergency Access

An additional safety note has been added as a result of the events following the earthquake in October of 1989. A power outage at the Lower Fort Mason restoration site rendered the electrically-operated gangway useless. As a result, the vessel could not be safely boarded for a period of almost four days. Although this was a rare occurrence, an event such as a fire in the adjacent building could have had similar results. It is therefore recommended that a manual system of lowering the gangway be installed for emergency use.

Estimated Cost for Safety Upgrades:

Engine room grating	\$ 1,200
Ground-fault interrupters	300
Oily-waste handling system	2,500

Fire-suppression system	12,000
Emergency access	500
Total	\$ 16,500

2-7.2.2. Restoration Planning

Implementation of the recommended treatment will require planning in greater detail than that given in the Historic Structure Report. To insure that the desired results are achieved over a possibly long-term project, all major planning work should be completed in the initial phase of the project. Of greatest need are the plans and specifications for the portions of the treatment involving major intervention (restoration, modifications, or additions). Work which is limited to preservation or in-kind replacement of fabric can proceed, provided that NPS requirements for documentation and assessment of impact are met. The major requirements for plans and specifications are listed in Section 2-9. "Recommendations for Further Study."

In addition to plans and specifications, a detailed scope of work should be developed for each major element of work recommended in the Historic Structure Report. As detailed planning work is completed, more accurate cost estimates and work schedules should result. The estimates and schedules presented in the Historic Structure Report should be updated to reflect this information.

Restoration planning should also focus on implementation of the project by formally identifying:

- The resources required from NPS staff and volunteer organizations;
- Qualified contractors for work which must be contracted out;
- Foundations and private firms which are potential sources for funding and in-kind donation.

The estimated cost of planning work is based on contracting the work through professional design agents. Itemized estimates are given in Section 2-9. "Recommendations for Further Study."

Estimated Cost: \$ 55,000

2-7.2.3. Drydocking: Essential Steps

Work items that can only be accomplished when HERCULES is on dry dock have been grouped under this heading. Most of these items are considered high priority steps, as they involve preservation of structure that is presently undergoing deterioration.

HULL: SURVEY, REPAIRS, AND COATING

HERCULES' most immediate preservation need is repair and coating of the hull. She has not been dry-docked since 1982 and is overdue for cyclical maintenance. Hull thickness measurements taken during surveys in 1987 and 1989 indicate areas of thin bottom plating (see Appendix 3-2. "Record of Ultrasonic Gauging"), and visual inspection confirms the hull is continuing to waste away from corrosion. To prevent further loss of historic fabric and reduce the danger of sinking, all areas of thin shell plating should be repaired and the hull coated inside and out. The following steps are required:

Hull Preparation and Survey

The primary purpose of the hull survey will be to locate all areas of dangerously thin shell plating, and wasted internal hull structure. Procedures will include visual inspection and ultrasonic gauging of the shell from inside and out. Exterior survey will be routine; visual inspection and gauging should be performed after the hull has been sandblasted and primed, and before thick bottom coatings are applied.

Survey of the hull interior should focus on the lower bilge area where the worst conditions of rust scale and wastage are seen, particularly at the edges of the cement bilge lining. Severe wastage is also suspected under the engine bed and other machinery foundations. Before these areas can be thoroughly inspected, considerable preparatory work is required, including cleaning the engine room bilges and selected removal of heavy rust scale and portions of the cement bilge lining in several compartments. Some of this work can be initiated prior to drydocking, but should be undertaken with extreme care to avoid holing the hull in severely wasted areas.

The following is recommended to facilitate inspection:

Forepeak Tank: Remove cement and scale along the edges of the cement lining in all frame spaces, port and starboard.

Forecastle: Remove scale along the joint between the forward bulkhead and the hull. Remove cement and scale in the area between frames 21 to 23, from "B" strake port to "B" strake starboard, and along the edges of cement the lining in all other frame spaces.

Boiler room: Remove cement around the bases of all four boiler saddles. Remove cement and scale along edges of the cement liner in selected frame spaces. Remove scale under hydrokinetor pump foundation (frames 30 to 32), and under fuel oil heaters (frames 35 to 36). Clean out oily sludge and de-grease aft end of the boiler room (frames 30 to 36).

Engine room: Remove all oily sludge and steam clean or chemically clean entire bilge area. Remove scale from selected areas of engine beds and hull beneath. Remove cement and scale along edges of cement liner, particularly between frames 65 and 70.

Aft Peak Tank and Lazarette Tank: Remove cement and scale from 50% of frame spaces, port and starboard.

This work will generate a considerable amount of oily waste and debris which must be removed from the vessel and disposed of. The job of cleaning and coating the bilges for preservation is far in excess of the work outlined here and can be performed while HERCULES is afloat.

Estimated Cost for Preparatory Work: \$ 9,600
 Estimated Cost for Survey: \$ 2,000

Hull Repairs

The recommended procedure for repairing wasted hull plating is to weld steel "doubler" plates over areas where shell plating is thin (less than .250" average thickness). Although doublers are not considered the best method of repair by modern ship repair standards, they offer advantages for repair of riveted historic ships. Doublers do not require the removal of shell plating as do welded inserts. As a result, there is no loss of historic fabric, nor is the appearance of the hull interior affected. In addition, installation of doubler plates requires less effort in cutting and fitting and is therefore more economical. Specifications should call for 3/8" thick ASTM-A36 plate, fully welded along all edges and plug welded at each hull frame. All doubler plates will be below the waterline and will have no visual impact on historic appearance when the vessel is afloat.

Estimating the amount of doublers needed is difficult until an out-of-water hull survey can be completed. How-

ever, using existing survey results (which indicate that as much as twenty-five percent of the total hull area may be dangerously thin) a rough estimate can be developed. Application of the standard formula for hull area yields the following result:

$$\text{Area} = [(2 \times \text{Depth}) + \text{Beam}] \times \text{Length Between Perpendiculars} \times \text{Block Coefficient}$$

or:

$$\begin{aligned} \text{Area} &= [(2 \times 18.0) + 26.1] \times 142 \times .50^* \\ &= 62.1 \times 142 \times .50 \\ &= 4,409 \text{ sq. ft.} \end{aligned}$$

$$4,409 \times 25 \% \text{ (estimated amount of thin plate)} = 1,102 \text{ sq. ft.}$$

Using 3/8" steel plate and the average shipyard rate of \$5 per pound for this type of work yields an estimated cost of \$82,650.

Additional hull work should be anticipated, including small welded patches and use of epoxy to seal plate seams and wasted rivets. An estimate for this work, based on 200 man-hours at \$40 per hour, is \$8,000.

Total Estimated Cost for Hull Repairs: \$ 90,650

Sandblasting and Coating of Bottom and Topsides

The entire underwater hull exterior will require sandblasting and coating during drydocking. Long-term preservation of the hull will be best served by using a high quality, state-of-the-art marine coating system for all underwater surfaces. It may be possible to save the existing topside coating by lightly sandsweeping and coating over the existing paint.

The recommended procedures and products are similar to those used during the drydocking of the NPS ship BALCLUTHA in 1986: the underwater hull should be sandblasted to "near-white metal" and several coats of epoxy anti-corrosive paint applied. Two coats of anti-fouling paint would then be applied to prevent the marine growth buildup that normally occurs between drydockings. Preventing the buildup of growth will eliminate the need to sandblast the bottom at every drydocking, thus simplifying cyclical maintenance and reducing cost. It will also benefit the long-term preservation of hull fabric, as each time the hull is sandblasted, a measurable amount of steel is lost from the hull plating and rivets.

* Calculated block coefficient of underwater hull.

In addition to epoxy, the topsides will receive a finish coat and boottop in the historic colors of the "Red Stack" fleet.

The following coating systems are recommended:

Bottom—from the keel to two feet above present waterline (estimated area 3,900 sq. ft.)

- 2 coats of Devoe Bar-Rust 235 at 8 mils dry film thickness per coat.
- 1 additional coat of Bar-Rust 235 on all rivets and plate seams.
- 2 coats of Devoe ABC-AF ablative anti-fouling paint at 4 mils dry film thickness per coat.

Topsides—from two feet above waterline to cap rail (estimated area: 3,600 sq. ft.)

- 1 coat of Devoe Bar-Rust 235 at 8 mils dry film thickness.
- 1 coat of Devoe P-50 Universal tie coat.
- 2 coats of Devoe Bar-Ox enamel in selected colors.
- Paint name, port of registry, and draft marks.

The estimated cost for sandblasting and coating is based on an average per-square-foot commercial rate of \$5 for hull bottom, and \$3 for topsides, including all materials and labor.

Topsides: 3,600 sq. ft. x \$3 = 10,800
 Bottom: 3,900 sq. ft. x \$5 = 19,500
Total Estimated Cost for Hull Coating: . . \$ 30,300

Inspection and Overhaul of Tailshaft and Bearings

Although the primary purpose of the following work is to return the propeller and shaft to operating condition, it is also the best way to insure their preservation. The condition of the shaft, packing gland, stern bearing, and propeller is not known. While on drydock, the shaft should be removed for inspection, and repaired as necessary. The shaft and stern bearing were probably in working order when HERCULES was laid up in 1962, yet it is likely that corrosion has taken its toll in the ensuing twenty-seven years. The drydocking budget should therefore include a contingency for machining the shaft and overhauling the bearing.

The packing gland will need to be cleaned and repacked, and may require repair. While the tailshaft and intermediate shaft are removed, the thrust bearing and its

lubrication system should be inspected, cleaned, and overhauled as necessary.

The propeller is probably in serviceable condition for the intended use of the vessel. It should be sandblasted and coated along with the rest of the bottom. If the propeller is found to be damaged, either from an event prior to lay-up, or from severe electrolysis, repairs will be needed. Such work should be allowed for under a dry-docking contingency fund.

Estimated Cost:
 For Overhaul \$ 18,000

Inspection and Overhaul of Rudder Assembly

The rudder turns freely, but little else is known of its condition. As with the propeller shaft, the best means of preserving the rudder assembly is to restore it to operating condition. In order to do this, the rudder and rudder stock will have to be removed on dry dock for inspection of pintles and gudgeons, carrier bearing, rudder trunk, and skeg. The rudder, stock, and skeg should be sandblasted and coated to the same specification as the hull. The rudder trunk, a steel tube approximately 8" in diameter and 4' long, may be difficult to sandblast, but should be thoroughly coated, as it is intermittently subjected to sea water immersion. The steady bearing, pintles, and gudgeons will require overhaul, alignment, and lubrication. It is possible that previous damage, excessive wear, or deterioration will necessitate repairs to the rudder assembly.

Estimated Cost:
 For Overhaul \$ 8,000

Inspection and Overhaul of Sea Valves

HERCULES has two underwater sea valves, both in the engine room. These valves and their thru-hull fittings are not only important to the operation of the vessel, they can result in serious hull leakage if allowed to deteriorate. Complete overhaul of all underwater sea valves, and coating and repair of thru-hulls and strainers, is therefore considered a high priority. Discharge valves above the waterline are not so critical and can be overhauled while the vessel is in the water. Complete overhaul is recommended for the following:

Sea water suction for fire pump; 6" valve on starboard side at frame 51-52.

Sea water suction for main circulating pump; 8" valve on port side at frame 51-52.

Estimated Cost: \$ 4,500

Structural Repairs

The majority of structural repairs HERCULES will need are not considered a high priority and can be carried out with the vessel in the water. The exceptions to this are repairs which require fitting and welding to internal hull structure below the waterline, as these actions could inadvertently cause hull leakage. The following work should be completed in dry dock:

Boiler Saddle Webs: Renewal of the four deteriorated boiler saddle webs will complete the boiler saddle repairs begun by volunteers. These structures are important as they provide support for the massive boiler. The lower ends of the webs are attached to the hull frames below a layer of bilge cement, where they cannot be viewed. Removal of the cement around the webs is included in the recommendations for hull survey. If inspection reveals the hull frames to be sound, repairs will involve welding new webs to the frames. If frames are also wasted, additional work will be needed.

Bulkhead at Frame 23: This bulkhead, between the boiler room and the forecabin, was originally watertight, but has been partially cut away where it attaches to the hull in the lower bilge area. An access hatch has also been cut in the bulkhead. This bulkhead should be restored to watertight condition to reduce the possibility of the vessel sinking in the event that either of the two adjacent compartments are holed. Sealing off the bulkhead will also help to prevent the spread of fire—a constant concern in an operating boiler room. Welding a steel plate between the web of frame 23 and the lower end of the bulkhead is work which should be completed in dry dock. Additional work may be required, such as restoring bulkhead stiffener angles. The access hatch does not have to be addressed during drydocking, as it is not adjacent to the hull.

Engine Bed and Other Repairs: The engine bed is known to be severely wasted, though the extent of necessary repairs cannot be determined until the area is cleaned and surveyed in dry dock. It is anticipated that the survey will reveal additional damage in other areas of the hull interior, some requiring repairs in dry dock. Based on existing survey data, this additional

work is estimated at roughly 300 man-hours at a standard "hot work" rate of \$50 per hour.

Estimated Cost for Structural Repairs:

Boiler Saddle Webs: \$ 8,000
 Bulkhead at Frame 23: 2,800
 Engine Bed and Other: 25,000
Total: **\$ 35,800**

Installation of Cathodic Protection System

An impressed current system is the recommended method of cathodic protection. This is an industry-standard technology designed to protect the underwater surface of metal hulls by preventing electrolysis (damage caused by stray electrical currents) and the natural corrosion which occurs when steel is in contact with sea water. The latter condition results from a breakdown of protective bottom coatings, a condition from which HERCULES presently suffers. As a preservation measure, this form of cathodic protection will provide the best assurance against further deterioration of the underwater hull.

An impressed current system was installed by volunteers in October of 1989. The installation was made in a temporary manner; permanent installation should be completed while on dry dock. The system will include a series of hull-mounted anodes and two "reference cells" which monitor the electrical potential of the hull and give an indication of the system's effectiveness. All necessary components and materials have been acquired by the HERCULES volunteers. Installation should be included as a basic bid item in a drydocking contract.

Estimated Cost (installation only): \$ 6,000

Taking Hull Lines

While HERCULES is on dry dock, measurements should be taken for developing an accurate set of hull lines. Although a preliminary set of lines were developed for the Historic Structure Report, these are based on measurements taken inside the hull, and are incomplete due to limited access in areas of the lower hull. Lines will complete the general documentation of the vessel, and will aid in stability and trim calculations.

Lines taking will require a crew of three for five days during the drydock period.

Estimated Cost: \$ 4,800

2-7.2.4. Drydocking: Optional Tasks

The work recommended here can be performed with the vessel afloat, but would be more efficiently carried out while on dry dock. If the optional tasks are not completed on dry dock, they should be addressed shortly thereafter.

Cleaning and Painting Bilges: Forecastle, Engine Room, Boiler Room

Cleaning and painting the bilges is as important to hull preservation as coating the bottom. This work would be best performed while in dry dock, where the bilges can be drained and moisture removed to allow proper application of paint. Due to the presence of machinery, sandblasting will not be practical in these compartments. The alternatives are steam cleaning, waterblasting, and manual cleaning. A combination of all of these methods may be required.

Forecastle: The bilges in the forecandle are free of oil but have a considerable amount of heavy rust scale throughout. Access is limited beneath the chainlocker and the potable water tank, possibly requiring manual removal of rust scale in these areas. Wasted hull frames in the bilges at the aft end of the compartment will likely require welded repairs. All welding should be completed before the bilges are coated.

Engine Room: Much of the bilge cleaning needed here will be accomplished as part of the preparation for survey. Additional cleaning and scaling will be necessary to get epoxy paint to adhere. Portions of the engine room will be difficult to paint due to limited access around the engine bed and the difficulty of completely removing oily residue. One possible solution is the use of an oil-tolerant epoxy such as Vepok, a product recently developed by the Valspar-Mebon paint company. A determination of the most appropriate type of coating to use cannot be made until a representative sample of the bilge is cleaned and the quality of the surface preparation assessed. A combination of coatings may be needed in the various areas of the engine room. Any use of soft-film coatings should be limited to areas which will not be frequently accessed by staff.

Boiler Room: Portions of the boiler room bilges have already been scaled and painted. Additional work is necessary to remove all rust scale and oily-residue. This work should be performed after the boiler saddle repairs are completed.

Estimated Cost:

Engine Room	\$ 11,000
Forecastle	5,500
Boiler Room	6,500
Total	\$ 23,000

Cleaning and Coating the Water Tanks

The water tanks are bulkheaded sections of the hull which were used to carry the large volume of fresh water needed by the boiler during long ocean voyages. They also functioned as ballast tanks. The tanks, including the forepeak, after peak, and lazarette, were originally coated with a cement wash. As noted in Appendix 3-1. "Survey Findings," this coating has largely broken down, resulting in severe wastage of the hull interior and bulkheads. Although the tanks have not held water for many years, they remain moist due to condensation, and thus continue to rust away.

The best method of preserving the water tanks is to sandblast or waterblast all surfaces and coat them with epoxy paint. To be effective, this work will have to be performed to a high standard of quality, a difficult task in the limited confines of the tanks. The cost would therefore be high. A less costly alternative is to waterblast and coat the tanks with a soft-film anti-corrosive coating, such as Eureka Fluid Film. Soft-film coatings adhere to poorly-prepared surfaces and will penetrate into riveted seams, thereby arresting corrosion. The major drawback of soft films is the greasy, slippery surface they create, thus making compartments difficult to enter or work in. Since the water tanks will need to be accessed only occasionally, this method of preservation is considered acceptable for use in tanks that will not be needed for storing feed water; the forepeak and lazarette tanks. Since the after peak tank will likely be needed for boiler feed water, use of soft-film coatings in this tank is not recommended, as the coating may result in contamination of the feed water. For the after peak tank, waterblasting and coating with epoxy is the recommended. The cost estimates given below are for waterblasting all three tanks, coating the fore peak and lazarette tanks with a soft film, and coating the after peak tank with epoxy. Completion of this work on dry dock is recommended, as there is a risk that waterblasting may create holes in the wasted hull plating below the waterline.

Estimated Cost:

Forepeak Tank	\$ 6,100
After Peak Tank	9,600
Lazarette Tank	5,300
Total	\$ 21,000

Cleaning and Coating Fuel Tanks

The fuel tanks were cleaned and a soft-film tank coating applied during the 1982 drydocking. Since that time, they have been filled with fresh water ballast. Although the tanks are in good condition overall, they still contain fuel oil residue and continue to corrode. The tanks should again be cleaned and coated to allow them to continue to function as ballast tanks without causing damage to hull and bulkheads. The most convenient time to perform this work is while on dry dock. Procedures will include steam cleaning, waste removal, and coating with a soft-film product. The tanks will need to be pumped out periodically. They should therefore be coated with a non-toxic, non-polluting product.

Estimated Cost: \$ 6,800

Restoration of Guards

Recommended treatment for the more than 300 linear feet of guards (rub rails) is full restoration, leaving all later modifications in place. Although composite wood and steel guards are not a preservation priority, there is a need to initiate work on them while in dry dock—removal of the steel chafing strap and guard timbers will allow sandblasting and coating of hull plating beneath the timbers. This work is essential to arresting corrosion of the hull plating under the guards and should be performed during preparation and coating of the topsides.

Long-term planning should include removing the riveted steel angles which support the guard timbers, clearing away the rust scale buildup between the angles and the hull, and riveting the angles back in place. Due to high cost and lack of skilled labor, it will not be practical to attempt this traditional type of marine repair in a modern shipyard. This work can be a long-term project for the Park preservation crew. While in dry dock, interim preservation measures should be taken to prevent further deterioration and to prepare for installation of new guard timbers. This work will include welded repairs, and sealing the gaps along the upper flange of the angles with epoxy filler.

Replacement of the 8" x 10" ironbark guard timbers (none of the existing ones are believed to be original fabric and few are salvageable) will be easier to complete while in dry dock, but can be undertaken with HERCULES in the water. The timbers should be fully bedded to the hull to prevent further corrosion. The existing steel chafing strap which mounts to the wood timbers can be epoxy-coated and reinstalled.

Estimated Cost:

Initial Work in Dry Dock	\$ 8,800
Completion of Restoration	19,200
Total	\$ 28,000

Summary of Drydocking

Essential Items

Towing to and from shipyard	\$ 5,000
Drydocking:	
—blocking, washdown, and services	22,000
Hull preparation and survey	11,600
Hull repairs	90,650
Sandblasting and coating hull exterior	30,300
Inspection and overhaul of shaft and bearings	18,000
Inspection and overhaul of rudder assembly	8,000
Inspection and overhaul of sea valves	4,500
Structural repairs	35,800
Installation of cathodic protection system	6,000
Taking hull lines	4,800
Subtotal	\$ 235,650

Contingency for Unspecified Work*	\$ 35,000
Total Cost Essential Items:	\$ 270,650

Optional Items

Cleaning and painting bilges	23,000
Cleaning and coating water tanks	21,000
Cleaning and coating fuel tanks	6,800
Restoration of guard rails (dry dock work only)	8,800
Subtotal	\$ 59,600

Contingency for Unspecified Repairs*	9,000
Total Cost Optional Items	\$ 68,600

Total Drydocking Cost	\$ 339,250
--	-------------------

* A contingency of 15 percent has been added to the estimate cost to cover work that can only be specified upon survey and inspection on drydock.

2-7.2.5. Installation of Electrical System

To meet the demands of public access and operation, HERCULES will need an overhaul of her electrical system. Due to safety concerns and other inadequacies in the present system, this work is considered a priority. It is recommended that most of the present electrical system be scrapped and replaced by a properly designed installation which will meet the future needs of the vessel. This system should be installed in a manner that will minimize impact to historic fabric and appearance. All remnants of the historic electrical system, including steam-powered generators, switch panels, conduit, and fixtures should be preserved in place and, if possible, integrated into the new system.

Plans and specifications are needed before work begins on installation of the electrical system. Design should be based on an analysis of the electrical needs for maintenance, operation, security, and interpretation. The system will need to provide the following:

- Lighting and service outlets sufficient for maintenance needs;
- Lighting for interpretation;
- Lighting for security;
- Circuits for bilge and fire pumps, air compressor, and moisture reduction heaters;
- A self-contained shipboard system for the vessel underway, including circuits for navigation lights and radio;
- Emergency generating capacity for vessel underway.

A load analysis, based on all anticipated power requirements, will determine wire sizes and circuit breaker capacity. It is recommended that the electrical system be designed to meet the minimum requirements for marine-type installations set by the U.S. Coast Guard, the American Institute of Electrical Engineers, and the National Electric Code.

Estimated Cost: \$ 32,000

2-7.2.6. Restoration of Boat Deck

The boat deck is presently a major source of ongoing deterioration in the vessel and is therefore considered a preservation priority. The wood decking is extensively rotten and leaks rainwater, with resultant decay of wood structure and corrosion of the steel deckhouse structure below. Efforts to seal the boat deck with roofing material

have been successful in reducing leakage, but deterioration cannot be effectively arrested without rebuilding the deck.

Survey data indicates that as much as one-third of the wood structure (decking, deck beams, and stringers) is decayed. In addition, there is evidence of severe corrosion of the steel deck beams and the upper ends of the deckhouse bulkheads. A full assessment of condition cannot be made until all of the canvas deck covering is removed and the rotten portions of the wood decking are cut away. Boat deck appurtenances such as skylight, ventilators, and railings are deteriorated to varying degrees and should undergo preservation along with the deck.

The recommended treatment for the boat deck is as follows:

1. In-kind replacement of all wood structure showing evidence of decay:
 - 1-1/2" x 3-1/4" tongue-and-groove decking
 - 3" x 3" deck beams
 - 3" x 5-1/2" deck edge stringers
 - 1-1/4" x 7" deck edge covering boards

Fig. 26. Boat deck, looking forward from port side, 1989. The lifeboat and skiff normally stowed here have been removed to Museum storage.

Photo: Tri-Coastal Marine



- fidley trunk sill timber
- skylight sill timber

2. Preservation of steel structure by sandblasting and coating with marine-grade epoxy:

- deck beams (corroded areas only)
- top of deckhouse bulkheads (corroded areas only)
- skylight coaming
- fidley trunk
- ventilator and tank vents

Sandblasting must be carried out with care to avoid damage to interior structures and furnishings within the deckhouse. All interior surfaces should be protected before sandblasting begins. Areas which cannot be effectively protected, such as the boiler room fidley and engine room, should not be sandblasted. An alternate method of surface preparation, such as manual scaling, should be used in these areas.

3. Replacement of all canvas deck covering with a synthetic fabric and elastomeric coating:

This waterproof covering system will provide a durable surface that duplicates the appearance of the original painted canvas. This modification is considered justified due to the greatly increased foot traffic that will result with public access to the boat deck.

4. Replacement of the iron pipe railings around the boat deck:

Much of the iron railing is severely wasted and cannot be repaired, although some of the cast iron stanchions may be salvaged for reuse. Approximately twenty-four of the stanchions are broken or rusted to the point they cannot be repaired. Casting or otherwise manufacturing duplicate stanchions will therefore be necessary.

Public access to the boat deck may require modification to the railings. The present railing height is 33", low by modern safety standards which usually call for a minimum of 42" for the top rail. Raising the railings to the modern standard may affect appearance. A determination of this requirement should be made by the Park safety officer.

Public access to the boat deck will require other measures, including securing the open areas along the deck edge in way of the lifeboats, and placing additional

barriers around the stair well access. These requirements can be accomplished by use of removable restraining ropes or cables, and will not significantly affect appearance.

Estimated Cost: \$ 48,000

2-7.2.7. Permanent Berth with Visitor Access

The transformation of HERCULES from a dormant historic ship to one which can be interpreted to the general public should be a primary focus of the initial phases of restoration. A major hurdle in achieving this will be the development of a berth that will allow safe public access. The present berth was selected as a temporary site to facilitate restoration efforts, and is not suitable for public access for two reasons: 1) the location at Pier One in Lower Fort Mason does not have adequate facilities for unattended public access, and 2) the surge in the slip at Pier One causes considerable rolling and heaving of the vessel, motions which will at times be uncomfortable, and possibly unsafe, for visiting public (limited guided tours might be scheduled during the remainder of HERCULES' stay at Lower Fort Mason).

Development of a permanent berth for HERCULES at the Hyde Street Pier is consistent with long-term planning for the Park as outlined in the "Interpretive Prospectus" (National Maritime Museum 1987), and the Hyde Street Pier Concept Plan (ibid.). A permanent berth can take many forms, but should:

- Provide a safe berth for HERCULES during severe weather;
- Allow safe public access over the entire normal tidal range;
- Allow convenient access for maintenance crew, equipment and materials;
- Provide adequate security and emergency access;
- Allow HERCULES to arrive and depart the berth without difficulty.

The recommended berth arrangement is a floating pier system held in position by guide piles. Such a system can be designed to meet all of the above requirements, with the possible exception of the first—providing a safe berth in severe weather will probably require supplemental storm moorings.

Given the present historic ship berthing arrangement at the Hyde Street Pier, the most protected site would be on the east side of the pier, opposite

BALCLUTHA, at the location HERCULES formerly occupied. A problem arises in that this area is now occupied by the paddle tug EPPLETON HALL and is the chosen location for a sailing berth for the scow schooner ALMA. In addition, the planned development of the Fisherman's Wharf area to the east will drastically limit the options for extending docking facilities in that direction. An arrangement might be worked out within this limited space by clustering all three vessels together in one facility. HERCULES and EPPLETON HALL could be berthed alongside one another, parallel to the Hyde Street Pier, and separated by a small fingerpier. In this arrangement, the tugs would be best positioned with their bows facing the shore. Due to the windage of their pilot-houses, they would ride out northerly storms better in this orientation. They would also present a more dramatic view to those entering the pier. The major limiting factor for this arrangement will be the room required to get EUREKA out of her slip for drydocking. It may be necessary to move one of the tugs, and a portion of the floating pier during this operation.

The design and construction of HERCULES' berth should be carried out as part of an overall pier development project, and the cost (estimated at \$ 115,000) included in the budget for pier development. To expedite the goal of achieving public access, the berthing facility will need to be in place by the time restoration work is completed at the present berth.

2-7.2.8. Restoration of Machinery: Boiler, Engine, and Auxiliaries

The general recommendation for treatment of HERCULES' machinery is restoration to operating condition. An effort to restore the steam machinery has been underway for the past few years, primarily driven by a volunteer effort. The machinery serves as a major attraction for many volunteers, as it one day will be for the visiting public.

Much of the machinery is presently undergoing restoration, or is otherwise in relatively stable condition. Restoration is not as high a preservation priority as stabilization; nevertheless, the machinery is among the most significant fabric in the vessel and is a key to returning life and activity to the vessel.

The recommended treatment for each piece of steam machinery is given in Appendix 3-1. "Survey Findings." The following general guidelines are based on the

Secretary's Standards (NPS 1989) and are intended to insure that historic integrity is maintained throughout the restoration process.

- Document all work involving the repair or replacement of machinery or machinery parts. Include date of the work, and materials and procedures used.
- Wherever possible, repair rather than replace parts, particularly those that are visible. If replacement is necessary, use traditional materials and procedures wherever possible.
- Make repairs durable, rather than temporary, and in a manner that will allow future adjustment or overhaul.
- Leave all significant historic machinery in its original location and orientation. This includes items not needed for operation. Such items should be preserved, or restored for interpretation.
- Document any fabric which must be removed in order to carry out preservation or restoration work. This includes any electrical wiring or piping.
- Where additions or alterations are needed for reasons of safety, or to facilitate maintenance, they should be made with care to minimize impact to historic appearance.

An accurate cost estimate for restoration of the machinery cannot be developed until all machinery is fully inspected and the extent of necessary repairs is known. The estimate given is based on general overhaul of each item, including minor repairs. The costs of restoring piping and installing insulation are not included.

Estimated Cost: \$ 57,600

2-7.2.9. Overhaul of Piping Systems

Portions of the vessel's existing piping will need to be reactivated for operation and maintenance of the vessel, including steam, compressed air, fuel oil, lube oil, fresh water, and bilge and fire piping. The condition of much of the piping cannot be determined without further disassembly, inspection, and testing. The general guidelines given for treatment of the machinery will also apply to all piping and valves.

Due to safety concerns, the steam piping and fuel oil piping will have additional requirements:

Steam Piping: The potential hazards associated with live steam warrant adherence to established stand-

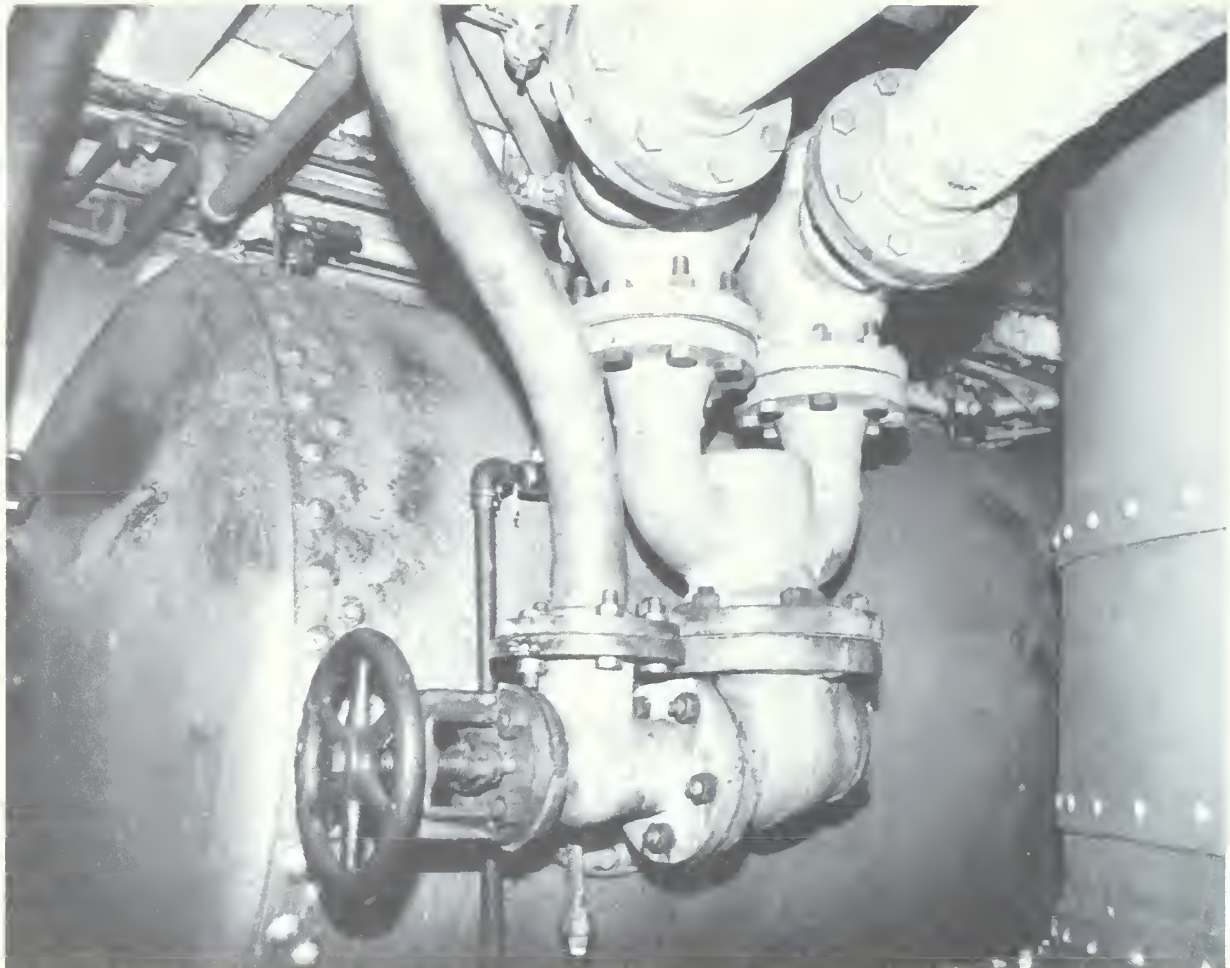

Fig. 27. The boiler safety valves, part of the complex system of steam piping. The riveted steam drum can be seen beyond, and the smoke stack is at right.

Photo: D. Birkholz

ards for installation, maintenance, inspection, and operation of all steam piping. The recommended standards are those established by the U.S. Coast Guard and published in the Code of Federal Regulations, Subchapter F, "Marine Engineering" (U.S. Government Printing Office 1987). One possible requirement would be the annealing of all copper steam lines. In this case, HERCULES' main and auxiliary steam lines would need to be annealed. By using electric-resistance heating elements, this procedure can be carried out by a contractor without removing the piping from the vessel.

Fuel Oil Piping: To prevent the possibility of fuel oil leakage (which could result in accidental fire or pollution), all fuel oil piping should be carefully inspected and tested prior to activation. The use of diesel fuel for firing the boiler will place a greater demand on pipe fittings, valves, and connections, as this fuel is less viscous, and therefore more difficult to

contain than the heavy bunker oil originally used. Modification of the fuel oil piping system may therefore be necessary in order to successfully deliver diesel fuel to the boilers. The installation of a diesel fuel tank is also recommended (see 2-6.2.23. "Modifications").

The estimated cost for reactivation of the piping systems includes overhaul of all valves, replacement of piping known to be deteriorated, and preservation of all elements not intended for reactivation.

Estimated Cost: \$ 38,400

2-7.2.10. Stack Repairs

The stack is largely intact, but requires considerable repair and preservation. The highest priority is arresting the ongoing corrosion on the stack exterior, particularly on the forward side. Initial treatment can be limited to

spot sandblasting and painting areas of corrosion. The most durable method of preservation is to repair wasted areas with welded patches, then sandblast the entire stack exterior and coat with a marine-grade epoxy paint. This work should be planned for future cyclical maintenance.

The extent of repairs required for the inner stack cannot be determined without further inspection from within the stack. Corrosion can be seen at two of the four riveted girth seams of the inner stack. If inspection reveals that appreciable riveted attachment has been lost at these seams, repairs will be needed to restore strength to the inner stack.

All six of the wire rope stack guys should be replaced, and the rusted steel access ladder mounted to the stack removed and repaired or replaced. A removable stack cover is recommended for all periods when the boiler is not in operation.

Estimated Cost:

Spot sandblast and paint	\$ 8,000
Replace steel ladder	1,600
Replace guy wires (6)	1,800
Total	\$ 11,400

2-7.2.11. Restoration of Deck Gear

The deck gear includes the anchor windlass, steam capstan, and towing engine, as well as non-mechanical equipment such as bits, davits, and chocks. The recommended treatment is restoration of all gear to operating condition. Specific recommendations for individual items are given in Appendix 3-1. "Survey Findings." Additional recommendations are as follows:

Windlass: The windlass will require replacement of several missing components. It is possible that duplicate pieces can be obtained, either through salvage, or from the manufacturer—the Hyde Windlass Company in Bath, Maine (now the Bath Iron Works). If not, the wildcats, clutches, brake assemblies, and hand pump gear will have to be replicated, either by casting or welded fabrication. The windlass base should be lifted for inspection and preservation of the wood pads and steel deck beneath. The windlass steam engine will require general overhaul.

Boat Davits: All davits are in fair condition and can be preserved by sandblasting and painting. The collars that allow each davits to cant outboard should be freed up and lubricated, as well as painted. The forward davit on the port side is bent and will require heating to straighten it. Restoring the davits to oper-

ating condition will require rigging the lifeboat falls (tackles), and setting up new guys. Further research will be needed to determine the original method used to haul the davits back to their vertical position after they have been canted outboard to hoist a boat. Additional tackles or guys may be required for this.

Anchor Davit: This davit is a replica of the original, which was removed in the 1930s. It appears to be frozen and may require heating to free it. The existing davit does not have as much curve as the original, and therefore not as much reach. Re-forging the davit to the original shape will be difficult and is not recommended at this time.

Roller Chocks: These are a later addition dating from the Bay towing period. Although removing them, along with the enlarged bulwark chocks, would improve integrity of the oceangoing configuration, they are in good condition and require little work to preserve. For the present, it is recommended they be left in place, and interpreted as features of the later historic period.

Estimated Cost for Restoration of Deck Gear:

Windlass	\$ 12,000
Towing engine6,500
Capstan3,200
Other (bits, davits)6,500
Total	\$ 28,200

2-7.2.12. Repair of Main Deck

The original riveted steel main deck is now a patchwork of welded doubler plates which were installed as the original plating wasted away. In some cases, a second layer of doubler plates has been added. Most of the doublers are now rusted through in local areas and are leaking.

Use of additional doublers to repair the deck is not recommended. The proper treatment is removal of all doublers and wasted deck plating, and installation of new riveted plate. The decklights originally mounted in the deck would be replicated and installed in their original locations. Full restoration of the main deck is a labor intensive task which is not warranted at this time—the deck is not deteriorating at a rapid rate, and the visual impact of the existing repairs is not major. For the present, treatment can be limited to preservation—sandblasting and coating the entire deck, and filling all corrosion pits and holes with an epoxy putty. If performed properly, this work will be a lasting repair and will restore a smooth appearance to the deck. In-kind replacement of wasted

deck plates is recommended as a long-term restoration goal.

The severe wastage of main deck structure at the forward end of the boiler room is a more immediate concern. Here, the 5" x 3" longitudinal steel angles below the base of the deckhouse are detached, and no longer providing structural support. The steel deck under the galley is perforated due to corrosion. Repair of this area through in-kind replacement of all weakened structure is recommended. To replace the steel deck under the galley, it will be necessary to remove all galley furnishings and the cement galley floor. Welding can be used for most of the steel work without affecting historic appearance.

Estimated Cost:

Initial preservation of deck	\$ 4,500
Full restoration	25,000
Structure repair	19,000
Total	\$ 48,500

2-7.2.13. Preservation of Deckhouse

The condition of the deckhouse is relatively stable, but the effects of previous corrosion have left it susceptible to further deterioration. The major preservation concerns are: 1) holes and loss of attachment created by wastage of steel plating, and 2) distortion and separation of riveted seams resulting from rust expansion. The deckhouse will be difficult to maintain without correcting these conditions. The need to preserve the original riveted appearance of the deckhouse will place a demand on the quality of repairs. The following procedures are recommended:

Wasted Plate: Small areas of wastage, such as holes up to 2" in diameter, can be repaired by use of an epoxy filler. All surfaces to be treated should be sandblasted, and sheet metal backing plates tack welded on the inside face of larger holes before fillers are applied. The filled areas should be sanded smooth to reduce visual impact. Larger areas of wastage, such as the lower edge of bulkheads around the winch room, will need to be cropped out and new plate and boundary angles welded in. All torch cuts in existing plate should be made in clean, straight lines. Fitting and welding of new plate must be of high quality to avoid the "patch-work" look of welded repairs. Welds should be carefully ground flush and all work sandblasted and coated. Doors which are too severely wasted to repair with epoxy should be replicated in riveted construction.

Rust Expansion in Seams: Minor rust expansion, that which has separated less than 1/8", can be sealed using epoxy filler. Filler compound must be carefully applied to maintain original appearance. Seams which have expanded up to 1/4" or greater, and pulled rivets loose, will be difficult to seal with epoxy. These areas should be carefully opened up by removing the rivets, and all rust scale cleaned away. Preservative coatings can then be applied, and the plates riveted back in place.

The major work outlined above, such as riveting and welding, can be carried out as a long-term project. The riveting, in particular, can be interpreted as traditional ship repair.

Estimated Cost:

Application of epoxy filler	\$ 1,600
Welded repairs	7,600
Riveted repairs	24,000
Total	\$ 33,200

2-7.2.14. Overhaul of Steering System

The steering system will need to be restored to operating condition before HERCULES can steam. This treatment is also considered the best means of ensuring preservation of the system, particularly the portions that are exposed to the weather, such as linkages and quadrant. The major components of the steering gear and their recommended treatment include:

Ship's wheel and pedestal: This original piece of equipment is in good condition and requires little work.

Steam steering engine: The steering engine is largely intact, but will need general overhaul, and replacement of steam lines.

Rod and chain steering linkages: These items require disassembly, cleaning, and coating or lubrication. Items showing excessive wear, such as guide blocks, will need to be replaced. Rusted areas on the main deck beneath the steering rods should be sandblasted and coated while the steering linkages are removed.

Quadrant: The quadrant should be sandblasted and painted. The four roller bearings that support the quadrant may require repair if they are frozen and will not rotate.

Rudder: The rudder and carrier bearing should be overhauled and repaired as necessary while on dry dock (see "Essential Drydocking Items").

Estimated Cost:

Overhaul of rod and chain linkages	\$ 2,800
Overhaul of steering engine	3,200
Total	\$ 6,000

2-7.2.15. Insulation of Boiler and Steam Lines

The original asbestos insulation on the boiler and steam piping has been removed as a health hazard. Due to the high temperatures generated by the steam system, almost all of the insulation will have to be replaced in order to safely run the machinery. The recommendation is to install Calcium Silicate, a non-toxic insulation material. Where possible, all insulation should be covered with canvas and painted to duplicate the appearance of traditional shipboard insulation.

The following insulation work will be required:

Main Boiler (15' diameter x 12' long): Install fixed insulation on the outside shell from the front of the boiler to the area of exposed staybolts at the rear of the boiler. The 4' x 4' area of the stay bolts will require a removable section of insulation to allow inspection of the bolts.

Boiler Accumulator Drum (5' diameter x 10' long): Install fixed insulation on all surfaces, except for the inspection plate which should be fitted with a removable pad.

Main Steam Line: Install fixed insulation from the stop valve at the accumulator to the main engine throttle valve (approximately 40'), except at the stop valve and at five flanged pipe connections where removable sections are needed.

Auxiliary Steam Line: Install fixed insulation from the stop valve at the accumulator to the engine room (approximately 50').

Individual Steam Lines for Auxiliaries: Install insulation of various lengths and diameters (approximately 600' of 3/4" to 2" piping).

Estimated Cost: \$ 48,000

2-7.2.16. Restoration of Bulwarks and Cap Rail

The restoration of bulwarks is an important requirement for restoring the original appearance of the vessel. Not only are the bulwarks and cap rail prominent features, they define the sheer, the graceful curve of the deck — a highly visible characteristic of the vessel.

The recommended treatment is to realign the steel bulwarks (they have been bent out of alignment by numerous collisions), making repairs as necessary to achieve a fair run of sheer in both the vertical and horizontal planes. The latter adjustment may require cutting and refitting the steel cap rail angle. A new 12" x 4" ironbark cap rail would then be installed. Replacing the cap rail before the bulwarks have been properly aligned is not recommended, as this will lock-in existing distortions.

The work of realigning the bulwarks will necessitate straightening and repairing several forged iron stanchions, and possibly the removal of rivets that attach the bulwarks plates to the sheer strake. To preserve the original appearance of the bulwarks, all visible repairs should be made by riveting rather than welding. An exception to this would be to leave in place the enlarged mooring chocks at the bow, and the welded stanchions in way of the reinforced rub rail on the starboard mid-bow. These are modifications dating from the later Bay towing period, and can be interpreted as such.

Although the bulwarks presently appear to be in poor condition, they are not a preservation priority; paint remains effective on the steel portions and the wood cap rail is either missing or has already deteriorated beyond the point of salvage. Restoring the bulwarks would be best accomplished by Park personnel after HERCULES is in place as an exhibit. This will allow interpretation of traditional ship repair work.

Estimated Cost:

Bulwark	\$ 24,000
Cap rail	13,000
Total	\$ 37,000

2-7.2.17. Reconstruction of Original Pilothouse

Removal of the raised steel pilothouse, and reconstruction of the original wood structure, will be the most dramatic step in returning HERCULES to her original form. While the existing pilothouse has historic significance, it is incompatible with the period of greatest significance — such raised pilothouses were not practical on oceangoing tugs due to the excessive motion experienced at sea. Reconstruction of the original pilothouse will have the added benefit of allowing visitor access and interpretation of this important area of the vessel. In the present arrangement, the pilothouse can only be reached by a steep ladder which is not considered safe for visitor access.

The existing pilothouse can and should be removed intact for preservation and interpretation ashore. The pilothouse is bolted to the deckhouse and can very likely be removed without damage to any existing fabric. Reconstruction of the original pilothouse should be carried out to detailed specifications and drawings that are based on thorough historic research. Plans for removal of the existing pilothouse should include construction of a suitable foundation for mounting it ashore.

Estimated Cost
(design and construction): \$ 50,000

2-7.2.18. Replication of Original Foremast and Mainmast

The wood masts were a prominent feature of HERCULES' oceangoing configuration and their reinstatement is recommended. Further research and design work will be needed to establish the arrangement of the foremast step, deck partners, and chainplates, as well as the dimensions and outfitting of the spars.

General recommendations include treating the new masts with wood preservative prior to installation, and hot-dip galvanizing of all mast fittings.

The existing steel mainmast should be kept in place in the interim. Locally wasted areas on this mast will require welded repairs if it is to remain in service.

Estimated Cost: \$ 19,800

2-7.2.19. Installation of a Donkey Boiler

HERCULES was originally equipped with a steam donkey boiler, a small boiler used to provide a limited amount of steam for auxiliary machinery and heating when the main boiler was shut down (*Nautical Gazette*, 1908). The donkey boiler, which was located at the starboard aft end of the boiler room, was removed sometime between 1935 and 1961 (see Figures 15 and 16). This item was an important feature of the vessel's original configuration. It is therefore recommended that a working replica of the boiler be installed in its original location.

A functioning donkey boiler will again play an important role, this time in the interpretation of the machinery. Operating the machinery for display will be difficult if the main boiler must be fired up every time—the main boiler takes many hours to come up to pressure, and several more hours to safely cool down. By comparison, the donkey boiler can be brought up to steam in little more than an hour and can provide enough steam to run any of the auxiliary machinery. The donkey boiler will have the added benefit of providing a backup source of steam while underway.

Acquiring a donkey boiler should not be a difficult task; there are many such boilers still in existence. The difficulty may come in finding one in good condition and similar to the original in design and size. Specifications for the original boiler stated that it was 36" in diameter and had an "aggregate area of grate surface [of] 7.06" (Dring). It was also reported to be capable of both oil and coal firing.

Getting the donkey boiler into the boiler room will require the removal of an approximately 4' x 4' section of main deck plating, and the cutting of one deck beam at the starboard aft end of the engine room. This is in an area where the main deck plating is severely wasted. The work will require replacing the deck beam and welding in a new deck plate. The donkey boiler will need a smoke stack, as well as steam and fuel oil piping. Cost for installation is estimated at a labor rate of \$40 per hour.

Estimated Cost (installation only): \$ 15,000

2-7.2.20. Interior Joinery Work and Furnishings

One of the final tasks in implementing HERCULES' treatment will be the restoration of accommodations and crew's facilities, and the furnishing of interior spaces. This work should await completion of all structural work, such as welding, sandblasting, and painting, which might result in damage to delicate joinery work and furnishings. Aside from the preservation of existing structure, all treatment of interior spaces should be determined through a "Historic Furnishings Report" (National Park Service 1985). In addition to restoration work, barriers will need to be

designed and installed to protect furnished compartments while allowing unobstructed public viewing.

General recommendations are as follows:

Forecastle: Restore to original crew accommodations from the oceangoing era, including bunks, lockers, and other furnishings. The portholes originally in the hull should be reinstated.

Saloon: Restore to configuration from oceangoing era.

Galley: Restore to configuration from oceangoing era after repair of steel deck beneath.



Fig. 28. The galley, as seen from the starboard entrance. The stove, sink, hand pump are operational.

Photo: Leigh Newcomb

Deckhouse Accommodations: Restore each compartment according to the certification marks seen on bulkheads and overhead. These historic markings state the general usage such as "Certified for 2 Seamen" and "Certified for Crew's Mess."

Captain's Cabin: The existing captain's cabin will be removed with the pilothouse. If reconstruction of the original pilothouse configuration is deferred, this cabin should be restored and interpreted in the interim.

Wheelhouse: The existing wheelhouse will not be accessible to the public. The reconstructed pilothouse should be furnished based on historic research and using existing equipment, such as the original wheel and the engine room telegraph.

Upper Portion of Engine Room: Remove decorative wood paneling for preservation and application of protective coatings. Reinstall after steel bulkheads have been coated.

Machine Shop: Restore to original usage according to certification marks ("Certified for Crew's Washroom") and other historical evidence.

Head: Restore to original configuration for interpretation as a non-functioning exhibit.

The cost for this work cannot be determined until further research is completed. It is estimated that as much as 2,000 man-hours may be required to complete the work. An estimate based on this level of effort at a rate of \$25 is given. An additional amount of \$20,000 has been added for materials, and acquisition of artifacts for furnishing the compartments.

Estimated Cost: \$ 70,000

2-7.2.21. Lifeboats and Skiff

HERCULES' existing lifeboat and skiff should be restored, or replicated, and returned to the vessel. The second lifeboat, which has long since disappeared, would need to be replicated. The boats should be fitted with traditional boat covers, and interpreted in their chocks on the boat deck. The boats should also be made capable of operation—launching them from their davits would allow seamanship drills and would be of interpretive interest.

Estimated Cost:
Restoration of existing lifeboat \$ 6,000

Replication of missing lifeboat 12,000
Total \$ 18,000

2-7.2.22. Potable Water Tank

The potable water tank is located in the lower fore-castle and presently provides water to the galley via a hand pump. Although not original, the tank is historic fabric and should be preserved. Treatment would include cleaning and coating the interior and exterior. The interior coating should be a type approved for use in potable water tanks.

Estimated Cost: \$ 3,000

2-7.2.23. Modifications

The following modifications are recommended either to improve safety or to facilitate operation and interpretation. Some proposed modifications, including installing a cathodic protection system, redesigning the electrical system, and altering the boat deck railings, have been discussed previously.

Installation of an Oily-water Separator

At the time HERCULES was built, little concern was given to the discharge of the oily waste and contaminated bilge water associated with the operation of a steam vessel. She therefore has no facility for holding or treating such pollutants. An important prerequisite to operating the steam machinery is the installation of an oily-water separator, a device designed to remove oily waste from bilge water so that the latter can be pumped overboard. Temporary measures for processing oily bilge water are recommended under the heading "Safety Upgrades." The system addressed here is a permanent installation. The oily-water separator will be a nonhistoric addition which should be installed in a manner that will minimize visual impact. The two compartments where oily water is a concern are the boiler room and engine room. Locating the separator in either compartment will necessitate running piping to the other compartment. It may be more cost effective to install two smaller units, one in each compartment. Interconnecting the two units with piping would provide redundancy in the event one unit should malfunction.

The installation will require plans and specifications. Additionally, procedures and facilities should be developed for the proper disposal of the oily waste generated through operation and maintenance.

Estimated Cost: \$ 22,000

Fuel Tanks

The installation of one or more fuel tanks will be a necessary modification for safe operation of the boiler and for steaming the vessel. HERCULES' existing fuel tanks are not considered suitable for the following reasons:

1. The tanks are integral with the hull, an arrangement no longer accepted by the U.S. Coast Guard due to the risk of fuel spillage through the hull. This risk will be greater if diesel fuel is used to fire the boiler, as it is less viscous and thus more difficult to contain in a riveted tank.
2. The tanks are far too large, having a capacity of 105,000 gallons. It will not be practical, or necessary, to carry more than a small fraction of this amount of fuel. If the tanks are not kept at least half full, with either fuel or water ballast, the vessel will float with her waterline below the band of protective doubler plates on the hull, thus exposing thin shell plating to the highly corrosive area of wind-and-water.

The recommendation is for installation of tankage which is tailored for the intended use of the vessel, and which meets U.S. Coast Guard standards. The size of the tanks will depend on the fuel capacity HERCULES will require for operation. HERCULES should be given a cruising range that will allow her to steam to other ports within the waters of San Francisco Bay and the Sacramento Delta. Port visits to other Bay and Delta towns will be an important facet of interpretation.

To complete a round trip to ports as far away as Sacramento, HERCULES will need a cruising range of at least 200 miles, or more than 25 hours at 8 knots. With an estimated fuel consumption of 100-130 gallons per hour, a fuel capacity of approximately 2,500 gallons will be needed. Tanks of this capacity can be installed with little impact to historic integrity by placing them within the existing fuel tanks (see Figure 29) where they would not be visible. The remainder of the space within the existing fuel tanks could then be used for water ballast.

The cost estimate given is for design and installation of two prefabricated tanks. Procedures would involve removing sections of the main deck, port and starboard between frames 36 and 41, to insert the tanks into the

hull. The cost of replacing the main deck plating is also included.

Estimated Cost: \$ 9,500

Emergency Generator Set

An important item of safety equipment for steaming HERCULES is a diesel-powered electric generator. All of HERCULES' machinery is steam-driven, with exception of the electrical equipment driven from shore power. If she loses steam while underway, all equipment, including fire pumps, bilge pumps, and electric generators, would be inoperable.

The recommendation is to install a diesel-driven generator of sufficient capacity to power electric pumps, lighting, and an electric compressor. The ability to supply compressed air in an emergency would allow the use of some of the auxiliary steam equipment, such as the fire and bilge pumps.

To meet these requirements, the emergency generator will have to provide at least 15 kilowatts of power. The location for the generator set should be selected to minimize visual impact. One possible arrangement would be to mount the generator set on a platform at the aft end of the engine room (see Figure 29).

Estimated Cost: \$ 17,000

Boiler Room Viewing Platform

Unguided visitor access to the boiler room is impractical and unsafe due to the long steep ladder which is the sole means of access. A glimpse of the boiler can be had from the deck grating at the main deck level, but this is not sufficient to properly interpret the boiler. This limitation can be overcome by installing a viewing platform along the aft boiler room bulkhead, at a point approximately 7' below the main deck level. This vantage point would provide a good view of the boiler and the layout of the compartment.

Access to the platform would be via the existing ladder, and a hatch in the platform would allow the crew to enter the boiler room. Although visitors would have to negotiate the steep ladder to enter and exit the platform, the vertical distance would be much less than the existing 15' descent to the boiler room. From the standpoint of safety, this arrangement is not substantially different from existing visitor access on other vessels in the historic fleet.

PROPOSED MODIFICATIONS

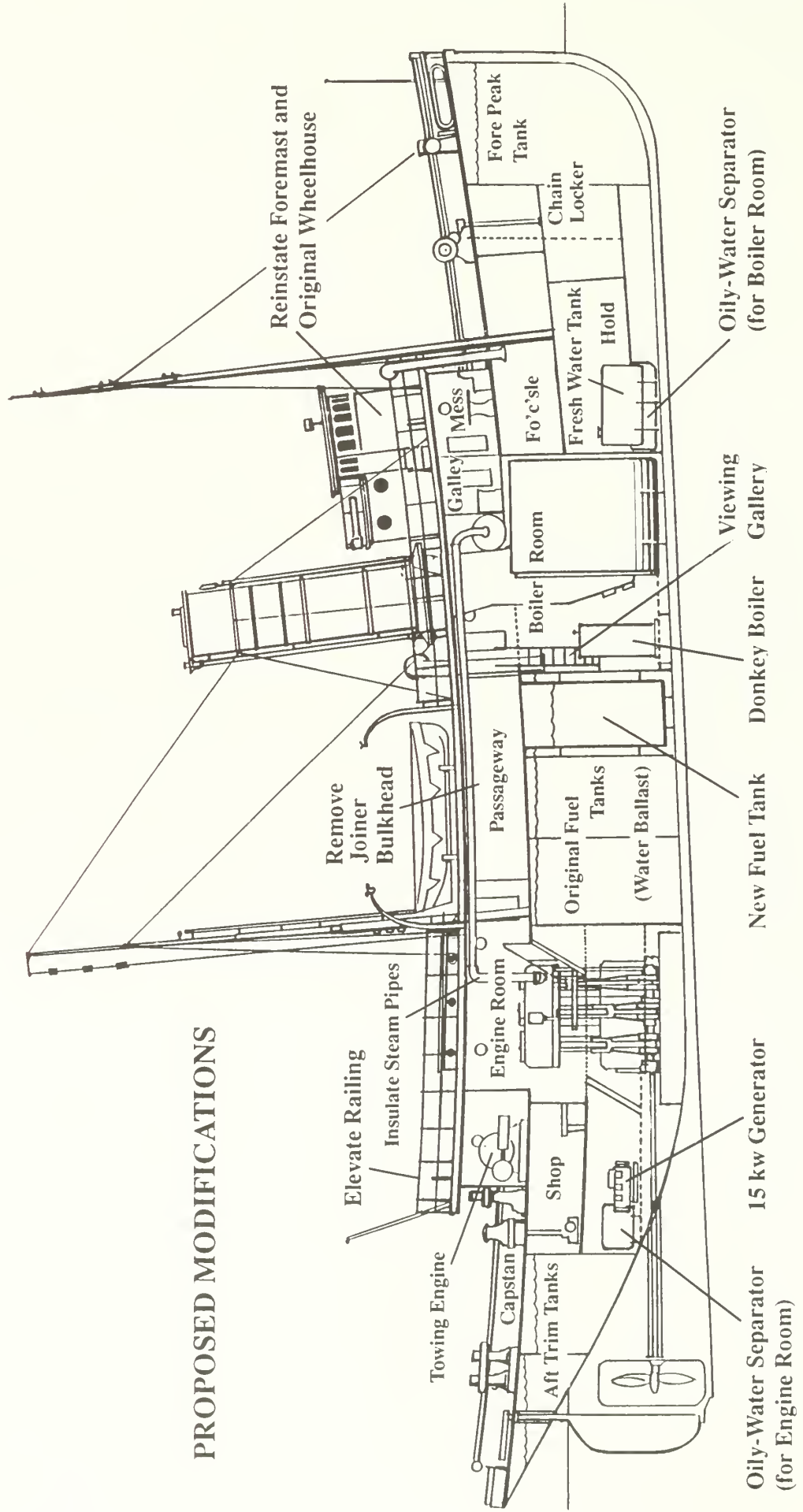

Fig. 29. Proposed Modifications

To improve safety, a handrail should be added to the aft side of the ladder. In addition, the skirt on the boiler room ventilator should be raised by approximately 6" to provide adequate headroom on the platform. These modifications will not significantly impact historic integrity.

The cost estimate given is for fabrication and installation of an all-steel, open grating platform.

Estimated Cost: \$ 3,500

2-7.3. Interpreting HERCULES

AN INTERPRETIVE ASSET

Although HERCULES has never been open to the public, she is potentially one of the most accessible and comprehensible vessels on the Park collection. Nearly all of her working spaces and crew's accommodations can be entered, or at least viewed, without making major compromises to historic integrity. Her functions as a tugboat are easily understood, and can be described with a minimum of interpretation. Even the functioning of the triple-expansion engine—a subject not generally understood by the layman—can be seen in an unusually straightforward arrangement. HERCULES' history is relatively simple, entirely integral with that of the West Coast and San Francisco, and closely related to the other vessels of the historic fleet. These factors combine to give the vessel excellent potential as a stationary museum ship. The ability to operate machinery at the dock, and steam on the Bay would further increase HERCULES' value as an interpretive asset.

Themes and media for interpretation of the ships of the Maritime Park are treated in the Interpretive Prospectus (National Maritime Museum 1987). The following is a suggested tour plan for the vessel.

VISITOR TOUR PLAN

HERCULES would optimally be berthed at a floating pier located on the east side of the Hyde Street Pier, with her bow facing inshore, and starboard side to the pier. Access would be via a long gangway from the Hyde Street Pier to the floating pier, and a smaller gangway between dock and starboard aft side of the vessel. The visitor would board on the aft deck, and would thus be directed in a clockwise circuit of the main deck.

Aft Deck: The visit would begin at the aft deck, the "business end" of an oceangoing tug. Capstan, towing and mooring bits, and steering quadrant are visible here, all expressive of their purpose. The towing engine (winch) will require interpretation. It is visible the large cable port in the aft end of the deckhouse and through doors at the sides, and can be interpreted without having the public enter the winch room.

Engine Room: Proceeding forward along the port side, the visitor next encounters the engine room. Doors on either side of the deckhouse are connected by an athwartships passageway, from which most of the machinery is visible. The engine space is easily accessible, with two ladders leading down to the upper engine room platform where most of the space can be viewed. Public access should be limited to the upper platform by placing a chain across the ladder leading to the lower level. Additional barriers will be needed along the edges of the upper platform to restrain small children. Barriers here, and in the boiler room, should be designed to provide safe viewing of the machinery while it is in operation.

Central Passageway: This narrow passageway leads from the engine room forward to the boiler room. It is an important feature of the vessel's design, allowing the crew to move from the winch room aft, to the saloon at the forward end of the deckhouse without having to venture onto the weather deck. That this arrangement was necessary offers insight into the sea conditions the vessel was designed to work in. The recommended tour path proceeds forward along this passageway to the engine room. Although headroom is low here due to the steam piping above, the insulation planned for the piping should cushion any accidental impact. To facilitate traffic, the nonhistoric joiner bulkhead midway along the passage should be removed. Depending on the level of heat generated by the steam piping, it may be necessary to close off this passageway when the boiler is fired.

Boiler Room: The central passageway opens onto the upper level of the boiler room which, like the engine room, has doors to the main deck, port and starboard. Some visitors would find the view from the open grating of the platform sufficient, and would continue through the port door and forward. For those who are more interested in the boiler, the viewing gallery previously described will offer a closer view. Graphic interpretation can be provided along the bulkhead adjacent to the viewing platform.

EXTENT of PUBLIC ACCESS

 INTERIOR SPACES OPEN TO THE PUBLIC

 INTERIOR SPACES VISIBLE TO THE PUBLIC

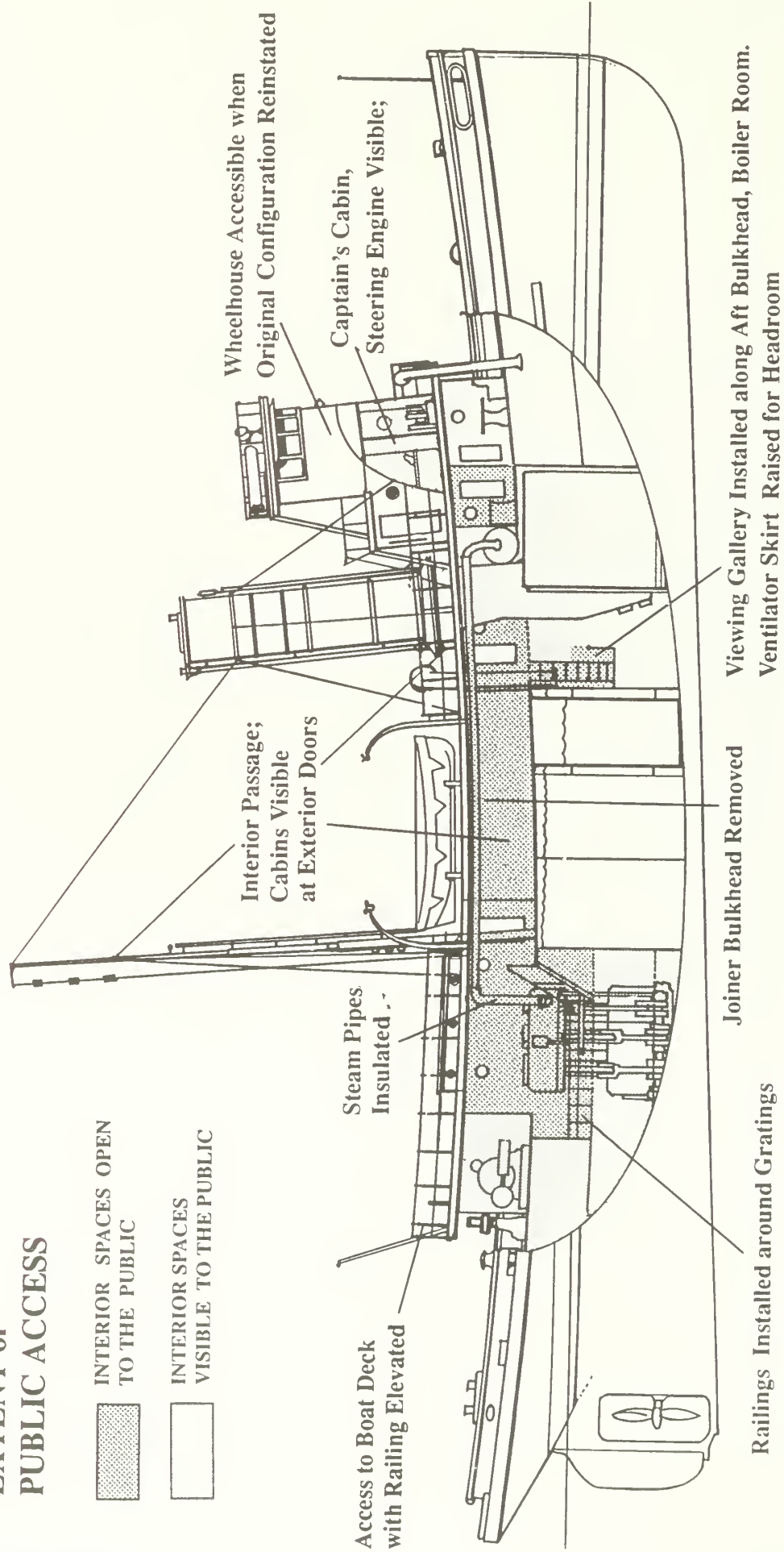

Fig. 30. Modifications for public access.

Galley: The galley forms an athwartships passageway through the deckhouse, and should be left open to the public. The galley has been maintained in operating condition by the volunteers. This use is the best interpretation of the space and should continue. The potential conflict between use and exhibit can be resolved by good shipkeeping practice and locking cabinets.

Saloon: This area is visible through a doorway on the forward side of the galley and a door on the port side of the deckhouse. The saloon is most expressive of the social environment aboard a vessel at sea, and should be fully dressed with period appointments. This treatment is not incompatible with intermittent use of the space as a volunteer and crew lounge, but public access should be limited by a chain barrier which allows a view of the space without entry.

Forecastle: It is not recommended that the forecastle be opened for general public access—it can only be reached by a steep and narrow stairway, and cannot be made safe for unattended access without undue alteration of the historic arrangement. It is nevertheless important to convey the fact that HERCULES, as an oceangoing steam tug, carried a much larger crew than a modern tug, and required more accommodations than are evident on the main deck. The forecastle should be restored and might be interpreted by special guided tour.

Boat Deck: Access to the boat deck is encountered as the visitor continues aft on the starboard side of the deckhouse. Full public access will require modifications to the railings, though access could initially be limited to the forward part of this deck, thus allowing viewing of the captain's cabin without the necessity of modifying the railings around the entire deck. At least one of the boats originally stowed here should be reinstated.

Pilothouse and Captain's Cabin: Pending eventual replication of the original pilothouse, the existing captain's cabin can be dressed and interpreted. Public access to the interior of the cabin is possible, and would allow viewing of the steering engine in the adjacent compartment. Depending on the level of restoration and furnishing of the captain's cabin, it may be more practical to limit access to the cabin doorway, and forego interpretation of the steering engine.

Deckhouse Cabins: The tour of the main deck would include some of the six cabins in the deckhouse, all

of which open onto the main deck. It is recommended that all cabins be restored, though it might be beneficial to assign one for staff use as an administrative or maintenance space. At least two cabins on each side of the deckhouse should be dressed and opened for viewing, with access limited by a barrier at the doorway.

2-7.4. Operation

Operation of HERCULES could range from firing the boiler while at the berth, to steaming the vessel on the Bay. Operation has been established as a treatment goal, but has not been further defined. Due to the complexity and potential dangers of the steam plant, and the value of the vessel as a cultural resource, a well-defined policy for operation should be established at the outset.

2-7.4.1. Making Steam at the Dock

The initial goal would be to get steam up and run machinery at the berth. This process can be interpreted through guided tours of the upper level of the engine room and boiler room. A viewing platform and safety barriers will eventually allow closer viewing by visitors on an unguided tour. Interpretation of the machinery could include turning the main engine over on steam, and running the reciprocating generator and pumps. The simultaneous presence of visitors and volunteers in the confined machinery spaces should be coordinated in a manner that will be beneficial to both.

The time required to get steam up in the large Scotch boiler (as much as eighteen hours) will make it difficult to fire the boiler and run machinery at frequent intervals. A program of firing the boiler one day a month, as is done on the JEREMIAH O'BRIEN, might be considered. The proposed donkey boiler could provide steam for operating most auxiliaries on a more frequent basis.

2-7.4.2. Steaming

Taking HERCULES out on the Bay would have an additional set of requirements, from fully restoring all running gear, to properly outfitting and manning the vessel. Although the U.S. Coast Guard does not require inspection of HERCULES (due to her Government status) it will be prudent to adhere to their standard for operation of the vessel.

2-8. Cost Estimates and Schedule of Implementation

2-8.1. Proposed Sequence of Work

The proposed sequence for implementation of the treatment has been arranged in four "Phases", each intended to achieve an interim goal, as follows:

Phase I will stabilize HERCULES by arresting deterioration and preventing further damage to historic fabric. Preliminary planning work, and steps needed to assure the safety of the vessel and persons working aboard, will also be completed in Phase I;

Phase II will focus on the steps necessary to achieve public access and initiate interpretation of the vessel;

Phase III will address the remaining steps needed to establish HERCULES as a fully-interpreted exhibit, including returning the vessel to operating condition;

Phase IV will complete all remaining restoration work, including the steps necessary to return HERCULES to her original configuration.

The following schedule of work is intended as a general guideline for completion of the major steps. Funding constraints or a change in priorities would necessitate alteration of this schedule.

Phase I

A considerable restoration effort is presently underway on HERCULES. The implementation of treatment is not intended to halt or redirect this work, but will result in a broadening of the restoration effort.

Safety: The first step will be completion of the recommended safety upgrades. These do not represent a major amount of work, but are nonetheless important. The scope of work should include any recommendations made by the Park safety officer.

- Repair of Engine Room Grating
- Installation GFCI's
- Oily-waste Handling System
- Fire-suppression System

- Emergency Access
- Other Safety Recommendations

Planning: Project planning can be initiated concurrently with the above work. Of primary importance are the plans and specifications needed to complete work scheduled for Phase I. These include:

- Drydocking Specifications
- Electrical System Design and Specifications
- Boat Deck Restoration Plan

To provide sufficient lead time for major Phase II projects, the following planning should also be initiated in Phase I:

- Design and Specifications for Berth
- Specifications for Oily-water Separator
- Specifications for Insulation of Steam System

All plans and specifications should be developed within an overall Restoration Plan which coordinates, directs, and monitors all restoration efforts. The Plan would be an extension of the Historic Structure Report, producing a detailed scope of work for each step, and thus providing more accurate schedules and cost estimates. The Plan should also identify all resources (staff, volunteers, contractors, and funding sources) necessary to complete the work. At a minimum, the portions of the Plan required to carry out all Phase I steps should be completed before major work begins.

Restoration Support for Volunteer Effort: As funding becomes available, support for the ongoing volunteer effort should be increased. A well-defined volunteer work plan should be developed to identify the level of support needed over the four-phase project.

Drydocking: The major item of work in Phase I will be drydocking the vessel. The steps classified as "Essential Drydocking Work" are of highest priority. All "Optional Drydocking Work" not completed on dry dock should remain as a Phase I goal, and can be initiated when the vessel is returned to her restoration berth.

Electrical System: Installation of a new electrical system is considered a priority due to safety concerns and

the need to provide adequate electrical service for the restoration effort.

Boat Deck: Restoration of the boat deck is essential to arrest the deterioration caused by rainwater leakage. This step is equivalent to fixing the roof of a museum to protect the exhibits inside.

Phase II

Additional Planning: All planning and studies not addressed in Phase I would be completed at this time:

- Historic Furnishings Report
- Floodable-length Study
- Plans and Specifications for Phase III and VI Work

Permanent Berth: Visitor access to HERCULES can be achieved following completion of her permanent berth at the Hyde Street Pier. Additional steps would be needed to achieve visitor access, including the initial development of interpretation, and installation of safety barriers on the vessel.

Operation of Machinery: The remaining steps in Phase II are those necessary to complete the restoration of the machinery to operating condition. This would allow active interpretation of the boiler, engine, and auxiliaries at the Pier, and would achieve the recommended level of preservation for these elements. Necessary steps include:

- Installation of Oily-water Separators
- Restoration of Machinery
- Overhaul of Piping System
- Insulation of Boiler and Steam Piping

Phase III

Preservation: Elements that have previously been stabilized, but have not yet been adequately preserved, would be addressed in this phase. Some of these items will require restoration at a future date:

- Repair of Stack
- Repair and Preservation of Main Deck
- Preservation of Deckhouse
- Completion of Guard Rail Repairs (begun in Dry Dock)

Requirements for Steaming: By this phase, most of HERCULES' machinery will be restored, and will have undergone operational testing at the dock. The remaining

steps necessary to steam the vessel on the Bay should be completed at this time:

- Overhaul of Steering Gear
- Installation of Fuel Tanks
- Installation of Emergency Generator

Additionally, General outfitting with safety and navigational gear will be required before steaming.

Completing Interpretation: All work needed to provide full interpretation of HERCULES (with exception of replication of the pilothouse and masts) would be completed at this time:

- Installation of Boiler Room Viewing Platform
- Installation of Donkey Boiler
- Restoration of Bulwarks

Phase IV

Completion of Restoration: Major work items that are not immediate preservation concerns and are not essential to interpretation or operation can be deferred to this final phase. Some of these items involve restoration work that would not significantly disrupt visitor access and could be completed over an extended period, with onboard interpretive of the restoration process.

- Restoration of Deckhouse
- Restoration of Main Deck
- Restoration of Deck Gear
- Reconstruction of Original Pilothouse
- Replication of Fore and Main Masts
- Restoration of Boats

2-8.2. Schedule and Cost

PHASE I

Safety Upgrades	\$16,500
Restoration Planning	35,000
Drydocking: Essential Work	270,650
Drydocking: Optional Work	68,600
Installation of Electrical System	32,000
Restoration of Boat Deck	48,000
Restoration Support	25,000

Total for Phase I \$495,750

PHASE II

Additional Planning	23,000
Permanent Berth with Visitor Access*	- 0 -
Oily-water Separator	22,000
Restoration of Machinery	57,600
Overhaul of Piping System	38,400
Insulation of Boiler and Steam Piping	48,000
Restoration Support	25,000

Total for Phase II \$214,000

PHASE III

Repair of Stack	\$11,400
Repair and Preservation of Main Deck	23,500
Preservation of Deckhouse	9,200
Completion of Guard Rail Repairs	19,200
Overhaul of Steering Gear	6,000
Installation of Fuel Tanks	9,500
Installation of Emergency Generator	17,000
Installation of Boiler Room Viewing Platform	3,500
Installation of Donkey Boiler	15,000
Restoration of Bulwark and Cap rail	37,000
Restoration Support	25,000

Total for Phase III \$176,300

PHASE IV

Restoration of Deckhouse	\$24,000
Restoration of Main Deck	25,000
Restoration of Deck Gear	28,200
Reconstruction of Original Pilothouse	50,000
Replication of Foremast and Mainmast	19,800
Interior Joinery Work and Furnishings	70,000
Restoration of Boats	18,000
Restoration Support	25,000

Total for Phase IV \$260,000

Total Project Cost \$1,146,050

* Funded from Hyde Street Pier development budget.

2-9. Impact of Proposed Treatment

2-9.1. Impacts

The proposed treatment will focus on restoring HERCULES to her original oceangoing configuration. This will result in an overall improvement in the integrity of the vessel's form and character as she appeared during the historically significant period. Implementation of the proposed treatment will primarily involve preservation and restoration, with impact limited to loss of deteriorated historic fabric through in-kind replacement. The major intervention called for in the treatment will vary in impact:

1. Restoring HERCULES to her original configuration will require the removal or alteration of fabric dating from later historic periods. The impact to historic fabric is considered justified in order to achieve the more important goal of restoring overall integrity.

2. Returning HERCULES and her machinery to operating condition will require the addition of nonhistoric elements, and replacement of historic fabric which could otherwise be preserved. Increased interpretive potential, better long-term preservation, and improved safety are the justifications for these actions.

3. Alterations and additions are required to allow visitor access to certain areas of the vessel. This is warranted in the effort to expand the scope and depth of HERCULES' interpretation.

The steps which will result in the greatest impact are as listed below.

2-9.1.1. Removal of Historic Fabric

Existing Pilothouse

The elevated pilothouse is the most prominent feature that is incompatible with the significant historic period. Its removal will be necessary for reconstruction of the original seagoing pilothouse. This will not result in the destruction of historic fabric; the pilothouse will re-

tain interpretive value as an exhibit ashore. Removal of the pilothouse is technically a reversible action.

Existing Main Mast

The present steel main mast will be removed for installation of a replica of the original wooden main mast. The steel mast dates from the later working period of the vessel (probably the 1950s) and is not remarkable in design or construction. The mast should be documented after it is removed, when it can be accurately measured. Preserving the mast after removal is considered optional.

2-9.1.2. Alteration of Historic Fabric

Boat Deck Railings

The proposed increase in the height of the boat deck railings for visitor safety will have a visual impact on the appearance of the railings from a distant vantage point, such as the adjacent pier. The degree of impact will be directly proportional to the increase in railing height. It may be possible to satisfy safety concerns with a minimal increase in railing height, thus avoiding significant visual impact.

2-9.1.3. Installation of Nonhistoric Elements

Boiler Room Viewing Platform

The viewing platform is an addition that requires little modification of existing fabric, with exception of the requirement to raise the height of the boiler room ventilator skirt. The open-grating design of the platform will minimize visual impact and will be compatible with surrounding structures. The platform will result in a minor inconvenience for crew entering the boiler room.

Fuel Tanks

Installation of the fuel tanks requires no major alteration of existing fabric and will have no visual impact. The removal of main deck plating will be necessary to install the tanks, and will be followed by in-kind replacement.

Machinery and Systems

Installation of two oily-water separators and an emergency generator does not require removal or alteration of historic fabric. The visual impact of oily-water separator and generator to be installed in the engine room will be minimal for the visiting public, particularly if an effort is made to make this machinery inconspicuous. The oily-water separator in the forecabin will not be visible. All work will be reversible.

Other nonhistoric additions are recommended. They include the impressed current cathodic protection system; the fire, bilge, and security alarm system, and the electrical system. The impact of these additions will depend on the design and method of installation. If this work is properly executed, impact will be negligible.

2-10. Recommendations for Further Study

2-10.1. Floodable-length Study

A floodable-length study will determine whether HERCULES would remain afloat and stable if any of the compartments in her hull become flooded, a situation that could occur due to hull leakage. The study involves a calculation of internal volumes of the hull and an analysis of stability under a variety of flooded conditions. The results will reveal the amount of reserve buoyancy and should indicate how best to ballast the vessel.

Estimated Cost: \$ 1,500

2-10.2. Historic Furnishings Report

Restoration of crew's quarters (pilothouse, cabins, forecabin, saloon, and galley) should be preceded by a Historic Furnishings Report as described in NPS 28 (National Park Service 1985). This document will determine the original usage and arrangement of the various compartments, and will direct any alteration or addition of built-in furnishings or joiner bulkheads, as well as the outfitting of each compartment for interpretation. Historic detailing of machinery spaces, including boiler room, engine room, and machine shop, should also be based on the Historic Furnishings Report.

Estimated Cost: \$ 7,000

2-10.3. Taking Lines of the Hull

A set of hull lines were produced in 1989 to facilitate development of the structural drawings for the Historic Structure Report. The lines are based on measurements from inside the hull. Although they are sufficiently accurate for their intended purpose, they lack accuracy in areas where interior measurement was not possible. Additional measurements should be taken when HERCULES

is on dry dock and the existing lines plans corrected accordingly.

Estimated Cost: \$ 4,800

2-10.4. Documentation of Machinery

Further drawings are recommended to complete mitigating documentation. The measured scale drawings produced for the Historic Structure Report are limited to structure, piping, and electrical system. These are not of sufficient detail to adequately document all of HERCULES' historic machinery. Scale drawings are recommended for the boiler, engine, shafting, and all other unique machinery and fittings.

Some of the historic auxiliary machinery was produced in quantity, and copies of the manufacturer's drawings may still exist. A search should be undertaken for existing drawings before any detailed documentation of these items is attempted.

Estimated Cost: \$ 22,500

2-10.5. Plans and Specifications

2-10.5.1. Drydocking Specifications

A complete set of specifications will be needed for contracting the drydocking of HERCULES. The specifications should include all "Essential" and "Optional" items listed in section 2.6.2.

Estimated Cost: \$ 3,500

2-10.5.2. Electrical System Design

The permanent electrical system should be carefully designed to minimize impact to historic fabric and appearance, and to meet all power requirements. Plans and specifications should be completed before installation begins.

Estimated Cost: \$ 3,200

2-10.5.3. Research and Design for Pilothouse and Masts

Further historic research and detailed construction drawings will be needed for an authentic reconstruction of the pilothouse and replication of masts.

Estimated Cost: \$ 5,000

2-10.5.4. Design of Fuel Tanks and Viewing Platform

These two items will be custom fabrications needing construction drawings and specifications for installation

Estimated Cost: \$ 1,300

2-10.5.5. Specifications for Installations

Specifications will be needed for installation of the oily-water separators, emergency generator, donkey boiler, and insulation for the boiler and steam piping.

Estimated Cost: \$ 8,000

2-10.5.6. Design of Permanent Berth

Design work for the proposed berth will include plans and specifications for the floating piers, gangways, utilities, and storm moorings. A bottom soil analysis will be needed before pilings can be driven. Design of HERCULES' berth would be a component of the overall planning for development of the Hyde Street Pier, and will require approval from the Port of San Francisco and from the Bay Conservation and Development Corps (BCDC). The berth design cost, estimated at \$15,000, would be covered in the budget for pier development.



SECTION 3
APPENDIX

3-1. Survey Findings

3-1.1. Hull Interior

HERCULES' riveted steel hull is transversely framed on 21" centers with an ironbar stem and sternpost. Frames and deck beams are 3" x 5" x 3/8" angle with plate bracket knees and plate floors. Shell scantlings were originally 1/2" in the sheer strake, and 3/8" for all strakes below. Shell arrangement is in-out strake construction with single-riveted seams, double-riveted lapped butts at the ends, and treble-riveted butts in the midships length. Six bulkheads subdivided the hull into seven compartments. Watertight bulkheads are located at frames 8, 36, 51, 70, and 77. The bulkhead at frame 23 (forward end of boiler room) is not watertight, but may have originally been so. All tank bulkheads are riveted to an oil-tight specification, and may have been designed to be used for either oil or water.

3-1.1.1. Forepeak Tank: Stem to Collision Bulkhead at Frame #8

Arrangement: The peak tank runs the full depth of the hull and has a set of swash plates on angle stanchions along the centerline. Frames, shell plating, and bulkheads are coated with a cement wash, a traditional tank coating. Access to the forepeak is through a manhole at the port aft end.

Condition: The cement wash coating is largely broken down and falling off. The underlying shell and frames are heavily corroded, particularly the rivet heads. Considerable moisture and active corrosion is seen. Corrosion of rivet heads averages approximately 50%. Wastage of frame averages about 30%. None of the ultrasonic gauging (see tables) revealed thicknesses which are excessively thin in areas that have not been previously doubled. There is very little corrosion between frames, shell, and liners, thus these internal members still retain good attachment. Floors appear in good condition. The collision bulkhead was gauged and appears to be adequate, though some scale was seen behind the cement coating.

Conclusions: The amount of wastage that has taken place to date is considered affordable considering the vessel is no longer in commercial service. No further wastage should be allowed as there is little reserve thickness left in the structure. All surfaces should be scaled and re-coated. Renewals are not recommended at this time but may be found to be necessary after scaling reveals the true condition of all surfaces.

3-1.1.2. Fore Hold: Bulkhead at Frame #8 to Bulkhead at Frame #23

Arrangement: A t'ween deck divides this compartment into upper and lower levels. Immediately abaft the collision bulkhead is the windlass engine room (fr. 8-12) containing a horizontal two-cylinder v-drive steam engine. To port is a small, wood-framed storeroom. The windlass room opens into the forecabin with additional small storerooms port and starboard. The forecabin is presently furnished with a sink on centerline forward, a radiator midships, two bunks to port, eight steel lockers aft and starboard, and a small wooden table. These furnishings are believed to date from HERCULES' later period of Bay towing; there is little evidence of the original forecabin arrangement. Access is from a wood ladder leading up to the saloon in the deckhouse. Joiner bulkheads and t'ween deck are wood tongue-and-groove construction.

The lower hold is reached by a ladder on centerline abaft the windlass room bulkhead. There is a lower deck level constructed of unfastened scaffold planks just above the floors. The chainlocker is a wood crib constructed of 3" x 12" planks. The locker is presently filled with 1" open-link anchor chain. There is one spill pipe to starboard. The chain locker is directly beneath the windlass.

On centerline is a cylindrical riveted potable water tank currently in use to supply the galley. This tank is 5' in diameter by 10' 2" long and is welded to an angle frame. The tank appears to have been longer originally and may have been shortened by welded modification.

Condition: The shell and frames are well painted and ground cork has been used in the paint (traditional) to help insulate the forecabin area. Two areas of the main deck are rusted through beneath the doors to the mess room above. These have been poorly patched with doublers.

The wood t'ween deck has been repaired in some areas, though some sections, such as the area under the storerooms, appear to be older. The deck is in fair condition and considered adequate at this time.

The bottom planking of the chainlocker is soft in places and beginning to rot, most likely due to rainwater running down the spill pipe. It remains sound enough to hold chain, provided further decay is prevented.

The frames and rivets are in generally excellent condition. The webs are slightly bent in the locations where local dents are seen in the shell, but this is not considered significant. The web portion of frames number 12, 14, 15, 16, 18, 19, 20, 21, 22 on starboard side, and number 11, 15, 17, 19, 21, 22 on port side have been renewed below the second hold stringer by welding of a 3" x 4" x 5/16" angle to the existing flange, thus forming a "Z-bar." Approximately a dozen frames show deformation of the flange due to expansion of rust scale between frame and shell. This problem is not considered serious as the corrosion has been arrested and sealed. The shell plate in "D" strake, starboard, at frames 10 to 12, is holed and badly rusted behind the doubler plate installed in 1982.

The floors are 16" deep plate with 3" reverse angles. From frame 13 through 23, the bottom 8" of each floor are completely rusted away due to long-standing bilge water. A non-original cement bilge liner 6" to 10" deep has been poured between frames 16 to 23. The cement has been shaped to cover the frame-to-floor connections. Condition of frame angles and shell below the cement is unknown, but suspect. The keelson has been renewed at some time during the tug's working life. The replacement is a 6" x 6" x 3/8" "T-bar" which is riveted to the floors, but welded at the butts.

Conclusions: The wasted floors and added cement indicate there may be a serious corrosion problem in the bilge of this compartment. At the next drydocking, at least some of the cement should be chipped out to determine condition of the underlying steel structure. Ultrasonics gaugings should also be taken from the shell exterior in this area.

3-1.1.3. Boiler Room: Bulkhead at Frame 23 to Bulkhead at Frame 36

Arrangement: The boiler is on centerline between frames 24 and 31, and is supported on saddles at frames 25 and 30. The boiler saddles rest on deep web hull frames. To starboard of the boiler are the pipes and through hull valves for the boiler blow down. Aft and to port of the boiler are a work bench, an air compressor, and an air receiver. To starboard is a boiler feed pump and the former location of the fuel feed pump. The bilges have been heavily cemented, leaving a sump 3' wide between frames 31 to 35. Access is by a thwartship ladder at the aft end of the room, leading up to the main deck level within the house. The main deck over the boiler room is decked with an open-grid cast steel grating.

The bulkhead at frame 23 is non-watertight, terminating 8" above the bottom of the hull. A small manhole has been cut through the bulkhead on the port side to allow access between the lower fore hold and the boiler room. The manhole is fitted with a non-watertight door. The bulkhead appears to have been insulated on the forward side. The insulation is now missing.

Condition: Frames and interior shell are in good condition above the turn of bilge. There is some scale expansion between frames and shell in way of "E" strake, port and starboard. This condition is somewhat worse to starboard. The angle bar attaching shell to deck on the starboard side is being lifted by expanding rust scale, probably as a result of repeated impacts the hull got while handling rail car barges. This condition may indicate why the addition of the enlarged steel guard rail was needed on the hull exterior in this area.

One area of severe corrosion was found in the shell plating, on the starboard side in "E" and "D" strakes, between frames 28 and 29. This is behind the blow down pipes and near a through-hull fitting. Here the shell is deeply pitted and measured .166" in thickness.

The deep web frame on the port side at frame 25 is rusted through at the bottom and the angles are spread apart by expanding scale just above the joint to the boiler saddle. On the starboard side, scale expansion is separating the web from

the deck beam bracket at top. All four of the deep webs have had some welded repairs between the lower stringer and the boiler saddles.

The flanged tops of all four boiler saddles have been renewed by volunteers in the last two years. The repairs were made by welding a shaped flatbar to the remains of the supporting web which extends down to the hull frames. The condition of the webs remains poor, with most wasted through where the web rises out of the bilge cement. The hull frames that the saddles rest on appear to be in good condition below the cement.

The section of keelson between the boiler and the bulkhead at frame 36 is wasted and weakened by corrosion. Strength of the keelson has been dramatically reduced by this condition.

Many of the support angles for the heavy steel boiler room gratings have been renewed and the gratings are now adequately supported.

The bulkheads at frames 23 and 36 are in good condition and are well painted. The main deck above the boiler room is in fair condition, with only local areas of corrosion.

Conclusions: Without watertight integrity of the bulkhead at frame 23, HERCULES could sink if a serious leak developed in either the hold area or the boiler room. Another liability of the existing bulkhead is that the fore hold is not fire tight from the boiler room. A fuel fire in the boiler room could spread through the bilge to the forehold, where it would be much more difficult to control.

The thin area of shell plating noted on the starboard side is considered a threat to watertight integrity and is evidence of the need to drydock the vessel in the near future.

The condition of shell plating and framing obscured by the cement beneath the boiler is uncertain. Some of this cement may have been applied as a remedial repair and thus would indicate severe wastage of the hull in the area. Portions of the cement should be removed to allow further inspection of the hull during drydocking. Completing the boiler saddle repair by renewing wasted webs is recommended before the vessel is sailed.

3-1.1.4. Fuel Oil Tanks: Between Bulkheads at Frame 36 and 51

Arrangement: The tanks are divided by a centerline bulkhead and are the full depth of the hull with the main deck serving as the tank top. To prevent sloshing of fuel, each of the two tanks is subdivided into six compartments by open swash bulkheads: a longitudinal bulkhead at the quarter beam, and transverse bulkheads at frames 41 and 46. The swash bulkheads are 1/4" plate. Access to each tanks is via a single manhole on the main deck.

Condition: The tanks are coated with a tacky black film that appears to be an oil-based preservative. The tanks were cleaned during the 1982 drydocking and have since been used for water ballast. There is 4" to 6" of sludge near centerline at the bottom of each tank, as well as sludge pockets on the hull and bulkheads. General condition is very good with minimal corrosion of internal members. Minor upsets (dents) were seen in the hull bottom in both the port and starboard tanks, between frames 42 and 44. A more pronounced upset measuring 1-1/2" was noted in the starboard tank between frames 48 and 49. The riveted seam between "B" and "C" strakes has been opened slightly, though no leakage was seen. This damage may have been the result of improper blocking at some previous drydocking or may be due to grounding.

An epoxy compound has been used to seal the seams of the bulkhead at frame 36. The frame spaces adjacent the bulkheads at frame 36 and 51 are filled with cement to the top of floors. These steps were taken to arrest fuel leakage through the bulkheads. One hole was seen in the top of the starboard tank. This is located under the aft bulkhead of the chief engineer's cabin and was caused by corrosion of the main deck in an area that is difficult to maintain.

Conclusions: The tanks are in the best condition of any interior area. They may have had extensive repairs over the years as evidenced by a mix of different types of rivets. The one rust hole discovered in the deck plating over the tanks indicates similar corrosion may exist under all of the wood bulkheads on the main deck above. Further investigation,

including removals of the joinerwork, is recommended before the tanks are filled to the top. The dent on starboard side, between frames 48-49, should be repaired by filling the separated plate edges with epoxy. The area should be investigated from outside the hull during drydocking.

Use of the fuel tanks for bunker oil or diesel is questionable. Being integral with the riveted hull, the tanks are susceptible to leakage through the shell. The result would be oil spillage into the Bay. Consideration should be given to modifying the tanks to be non-integral.

3-1.1.5. Engine Room: From Bulkhead at Frame 51 to Frame 70

Arrangement: The engine room is open at the main deck, the cylinder heads being nearly flush with deck level. The upper engine flat is decked with cast steel gratings as in the boiler room. This flat is about 6' below the main deck level, and the grating does not extend past the line of the deckhouse. Aft of the engine room, a wooden t'ween deck with a wooden forward bulkhead encloses a shop area. On the grating level to starboard, and just forward of the shop is the steam dynamo and switchboard. Within the shop is the steam engine for the capstan.

On the lower grating level, about 16" above the deep floors, is the remaining auxiliary machinery. To port and just abaft the fuel tank bulkhead is the main circulating pump. Aft of the pump is the hotwell. The condenser and beam pumps are also located here, on the port side of the main engine. To starboard are the duplex steam pumps for fire, bilge, and general service. Lube oil tanks are hung above and outboard, under the main deck.

Abaft the engine is the thrust bearing. The stern gland and stuffing box are in the bulkhead at frame 70.

Condition: As elsewhere in the ship, the upper portions of the interior shell and framing are in very good condition. The problems are to be found lower down, where much corrosion is seen in the shell around engine and auxiliary machinery foundations.

The shell has one particularly thin area between frames 59-60 at the land of "C" to "D" strakes, on the port side. Plating is almost wasted through in this area.

The bilge for five frame spaces forward of the stuffing box has been heavily cemented to about 3' deep. This was done either to facilitate drainage to a sump, or as a repair for corrosion in this area. The cement sounds hollow aft and heavy scale can be seen between the shell and the cement. Ultrasonic readings showed thin plate in this area.

The upper portion of the hull on the port side was sandblasted and primed by volunteers in 1989. This work has left a fine abrasive dust throughout the engine room.

The lower stringer to port between frames 61 and 70 is being forced apart by expanding rust scale and is of reduced effectiveness.

The engine beds consist of deep transverse floors with intercostal plate brackets port and starboard. The web of the floor, at frame 52 to port, is rusted through as well as the reverse flanges at 52, 53, and 54. These floors are in the area of the hotwell, beam pump, condenser, and circulating pump—in other words, the hottest, wettest, and most corrosion prone area.

The t'ween deck shop sits on 1-1/2" tongue-and-groove decking over 3" x 6" wooden beams. The beam at frame 68 is cracked and sagging under the weight of a steam pump in the shop. The wood beam against bulkhead 70 is rotten and heavy scale has built up on the bulkhead and stiffener in this area.

The shop deck has various local areas of rot, none of which are considered serious at this time. The deck is sagged down on centerline due to deformation of the steel beams (3" x 4" x 5/16" angle) which back up the wooden supports. At some point, an attempt was made to suspend or lift the shaft from these beams which resulted in bending of the beams.

Pillars of 3" round bar are located port and starboard on frames 62, 64, 66, and 68. These function to support the tow engine and were supplemented by pillars of 3-1/2" x 3/8" double angle, which are now suffering deformation from expansion of scale in some locations. Provision for suspending the shaft has been made by welding 6" x 6" x 1/2" angle strongbacks across these pillars.

The lower gratings are 3/16" diamond plate: a combination of old steel plates forward, and some new aluminum ones aft. Several of the steel gratings were formerly wasted, as were their supporting angles. These have been replaced by volunteers in the last few years and are now considered adequate.

The upper engine flat gratings are in good condition, but the steel angle and hanger rods that support them are no longer properly attached. Many of the bolts between the hanger rods and angles have sheared off due to corrosion. A support bracket at the forward port corner of the flat has also lost its bolted attachment due to wastage.

Conclusions: The engine room bilge appears to be in the worst condition of any area in the ship. An intensive survey of this area is warranted due to the extensive corrosion seen in the areas which were accessible. Before a thorough survey can be performed, the bilges will need to be cleaned, and selected portions of cement removed. Due to the possibility of thin shell plating, this work should be performed during drydocking.

The upper engine flat is considered unsafe for heavy loading. The gratings should be removed and all support angles scaled and inspected. All bolted connections should be renewed, along with any angles or brackets that are found to be seriously wasted.

3-1.1.6. Aft Peak Tank: Between Bulkheads at Frames 70 and 77

Arrangement: The aft peak tank is a feedwater tank through which the stern tube passes. The tank runs the full depth of the hull and is fitted with two non-watertight swash bulkheads, running fore and aft and dividing the tank into thirds. This tank is coated with a thin cement liner, as in the forepeak.

Condition: The cement lining is delaminating from the shell due to expansion of rust scale. Swash plates are heavily scaled, as are many rivet heads. Bilges are filled with scale to within about 8" of the top of the deep floors.

Conclusions: Based on the ultrasonic gaugings and comparison with the forepeak, this compartment does not represent an immediate liability. The aft peak will require scaling and re-coating in the future in order to arrest ongoing corrosion.

3-1.1.7. Lazarette Tank: From Bulkhead at Frame 77 to the Stern

Arrangement: This tank was used for additional feedwater or ballast water. It runs the full depth of the hull at this point, and is cement-lined like the other water tanks. The transom is located here, just aft of frame 80. Aft of the transom are the sternpost and rudder trunk, and the radiating cant frames of the counter stern.

Condition: The lazarette tank is in generally better condition than the other water tanks (refer to the gauging tables for ultrasonic readings). The cement lining is broken down and scale is seen on shell and internals, though to a lesser degree than in the other tanks. The deck plating shows crevice corrosion around the deck beams in way of the bitts, probably from working of the plate in this area. This is not considered serious at this time.

Conclusions: The tank will require scaling and re-coating as part of an overall preservation plan but is considered of lower priority than the other compartments.

3-1.2. Hull Exterior

3-1.2.1. Shell Plating

Arrangement: The hull has seven strakes of plating per side, and a flat plate keel between the stem and rudder skeg. There are bilge keels along the midsection, port and starboard.

Condition:

Topsides: A belt of doubler plates was installed along the entire length of the waterline in 1982. The doubler plates are 3/8" thick and are bolted to alternate frames rather than plug welded to each frame as is the usual practice. The heads have sheared off of several of the bolts due to crevice corrosion. The shell plating from the waterline to the bulwarks is coated with black coat tar epoxy that was applied in 1982. This coating has generally held up, but corrosion is seen along plate seams and rivets near the waterline.

Bottom: The condition of the bottom cannot be determined without drydocking. Ultrasonic gaugings indicate loss of plate thickness, but much of this wastage may be due to interior corrosion. An impressed current cathodic protection system has recently been installed and activated by volunteers.

Conclusions: HERCULES is long overdue for drydocking and bottom maintenance. The cathodic protection system will help to slow corrosion of the underwater hull in the meantime. The loss of bolt heads on the doubler plates may allow seawater to leak between the doublers and the shell. These bolts should be inspected during drydocking and sealed with weld if found to be leaking. Drydocking should also include inspection of the rudder, shaft, propeller, and seachests.

3-1.2.2. Guards

Arrangement: There are two guards, or rub strakes, mounted on the hull exterior. The upper guard is the heavier of the two and runs the entire perimeter of the vessel. The lower guard is about 4' below the upper guard and extends for a little more than the midship half-length of the vessel.

The upper guard consists of an 11" square timber bolted through the shell and positioned between the flanges of two angles which are riveted to the shell. Outboard of the timber is a steel flat bar chafing strap. The upper angle is 3" x 3" x 3/8" and is the same size and at the same level as the gunwale angle connecting the deck to shell. The two angles share three-ply rivets through the sheer strake. The added stiffness this provides the hull is probably a contributing factor to the lack of corrosion between sheer strake and gunwale angle.

The lower guard was originally of the same construction but has undergone extensive welded repairs.

Condition:

Port upper guard: The timber is generally still hard on the surface but rotten internally. A 6' section is missing aft, revealing deeper pitting of the shell underneath, and severe rot in the timber pieces aft. The lower angle shows some rust-bulging away from the shell between rivets.

Port lower guard: The angles are suffering from rust scale expansion in the forward third of this guard. The after two-thirds have been repaired using a steel channel secured by welding to the original angles. Midships, the shell doubler plates (installed in 1982) have been fit around, and welded to, the guard.

Starboard upper guard: The flange of the upper angle has been renewed with a welded flatbar along most of this side. The timber has been renewed in fir (originally oak) for a quarter of the length aft of midships. Wood is generally rotten all along, especially midships. Forward on the starboard side, for a length of 30', the guard has been built up as a

welded box beam to better withstand impact with rail barges. The steel encases the timber and is open at the forward end. This allows water to run down the sheer inside the guard and is likely causing heavy internal corrosion.

Starboard lower guard: The lower flange suffers from expansion of rust scale along the first 30', and has been repaired with welded construction aft of this point.

Conclusions: Although the guards do not present an immediate problem, further inspection will likely reveal severe corrosion between the wood and the shell. Restoration plans should include repairs to these members. Deteriorated wood should be renewed, and the steel underneath repaired and coated. In the short-term, the rate of corrosion may be slowed by sealing the wood with seam compound and coatings.

3-1.3. Main Deck

Arrangement: The main deck is all-steel construction. Original plating thickness was either 5/16" or 3/8", with lapped riveted seams and strapped flush butts. With the exception of a small area between the windlass and the deckhouse, the entire deck has been overlaid with welded doubler plates. These doublers conform to the laps of the riveted plates and are welded to the toe of the gunwale bar and house boundary bar.

Condition: Much of the doubler plating is deeply pitted due to corrosion. To starboard, the doubler is holed in at least two places abreast of the boat deck ladder, and in approximately twelve places alongside the engine room—the lowest point of sheer. To port, the doublers are holed in numerous places in way of the engine room and abaft the house. The deck was formerly heavily corroded along the port and starboard sides, but has recently been sandblasted and coated in these areas.

Conclusions: The overall condition of the deck is not a major problem at the present time. The ultimate long-term solution would be to cut away the wasted doublers and renew the original deck plating to the riveted construction. A less costly alternative would be to renew the doublers. This is preferable to adding more layers of plate. The condition of the present surface is considered salvageable, if after scaling or sandblasting, all holes are ring-welded and pits filled with an epoxy compound.

3-1.4. Bulwarks

Arrangement: Bulwarks are 1/4" plate riveted to the sheer strake and supported with round bar angled stanchions. The bulwark plating is stiffened by a 2-1/2" x 2-1/2" x 3/8" cap rail angle riveted to the upper edge. The bulwarks are about 23" high and a 4" x 10" oak caprail is bolted through the upper angle, raising the height to 27". A topgallant rail of about 6" x 7" is fitted for the first 30' from the stem.

The first 6' of bulwarks aft of the stem have been altered by cutting out the hawse holes to make a large fairlead port. Approximately 7'6" abaft the stem is a thwartship I-beam supporting fairlead rollers. This is non-original equipment.

The bulwarks also appear to have been modified across the stern by removal of the plating around the stern and welding of a fairlead bar perpendicular to centerline, at 4' from the stern.

Condition: The forward fairlead rollers are frozen and the pin condition is unknown. The I-beam supporting the rollers creates a water trap across the forward lower edge, resulting in corrosion of the deck plating.

3-1.4.1. Port Bulwarks: From Fore to Aft

Several generations of repair work are in evidence, incorporating both riveted and welded work. The upper flange of the cap rail angle is rusted through for a length of 3' at about 14' abaft the stem.

The oak cap rail is missing for a length of about 50' midships, but is still in place forward and at the stern. The remaining rail has soft surface rot for the entire length and deeper pockets of rot in way of checks all along. With appropriate treatment and coatings the oak rail will hold its form for some years but will eventually require renewal.

Approximately 60' of bulwarks midships has been partially renewed with welded plate. The renewal is very poorly done, and slopes inboard, conforming to earlier damage and bent bulwark stanchions.

The original bulwarks were cut away above the sheer strake, leaving a strip of original metal riveted to the sheer strake to which the replacement plating was welded. This original piece suffers from expanded rust scale which is forcing it away from the sheer strake. The riveted butt straps were retained and the new plate welded to either side of them. The butt straps are so deteriorated that they cannot be properly preserved.

Aft of the renewed area the bulwark is an earlier repair, carried out by riveting to the sheer strake and welding on a new cap rail angle. This was a good compromise and has held up well with only minor pitting and moderate deformation of plate from expanding rust scale along the riveted joint.

3-1.4.2. Starboard Bulwarks: From Fore to Aft

The first 26' abaft the stem has been renewed by riveting to the sheer strake. There is some rust-bulging along this line but overall condition is fair. From this point to near midships the bulwarks appear to be original plate, with severe wastage along the cap rail angle flange and the lower seam.

From midships to about 8' from the stern, the bulwarks are an incomplete welded renewal to the same bad standard as the port side. The condition is worse because the cap rail angle was only skip welded and scale is now bulging the plating away from the angle between the welds.

From the welded renewal to the stern, the bulwarks appear to be original plate and are severely wasted along both upper and lower edges.

The wood cap rail is still in place, except in the midship area, and is rotten along its entire length.

The bulwarks have been reinforced for a length of 30', from forward of the starboard bitts to abaft the stack, by a an 18" x 11" welded box beam which encases the upper guard. The bulwarks have welded plate brackets inboard of this guard. These additions were made in the same period that the starboard guard rail was reinforced.

Conclusions: Initial preservation of the bulwarks should include sealing of the scale packed seams in order to arrest the destructive expansion of rust scale. The remaining oak cap rail can be preserved with appropriate rot treatment and coatings, and will hold its form for some years. Beyond this action, the bulwarks can await future restoration and are not an immediate liability. Most of the bulwark repairs are believed to date from the latter historic period, and although they should be considered historic fabric, they are of such poor quality that eventual restoration is recommended. The proper method of renewal would be a combination of welded and riveted construction which closely duplicates the original bulwarks.

If HERCULES is to be opened to the public, the bulwarks may need to be supplemented with a stanchion and wire course handrail.

3-1.5. Superstructure

Arrangement: Riveted steel, house is attached to deck by a 3" x 3" x 3/8" angle boundary bar. The lower side plating is 3/8" x 21-1/2", and is a significant member in stiffening the deck. The upper side plating is 3/16" thick, and rivets to an upper strap of 1/4" x 6" flat bar, to which is riveted the 2-1/2" x 2-1/2" x 1/4" angle for securing the deck beams.

The exterior is stiffened and divided into panels by vertical straps of 1/4" x 4" flat bar, and interior framing is 2-1/2" x 3" x 5/16" angle on 24" centers. Doors are plate steel and are reinforced with flat bar straps. All doors are non-watertight.

Transverse steel and wood deck beams support the top of the house which is called the "boat deck." A description of this deck is given in the section "3-1.6. Boat Deck."

3-1.5.1. Deckhouse Exterior

Arrangement: The deckhouse is approximately 85' long and averages 15' in width. It has a round forward face and sides which are neither parallel to the centerline nor to the deck edge. The arrangement of doors and portholes is asymmetrical, there being nine doors down the port side and seven to starboard. A ladder to the boat deck is set in a well to starboard.

Condition:

Deckhouse, Port Side—Reading from forward to aft

- Top strap around the radius of the house is "rust-bulged" off of its rivets.
- Vertical strap No. 1, behind the steering chain cover, is heavily pitted.
- Messroom door is rusted through at bottom and straps are rust-bulged around perimeter.
- Top strap is heavily scaled over messroom doorway.
- Vertical strap No. 2 is rust-bulged at the bottom 6".
- Galley door is severely wasted along top and bottom edges of lower half. The entire door is rust-bulged at straps.
- Vertical strap No. 3 is rust-bulged 6" in middle.
- Vertical strap No. 5 is severely rust-bulged over the lower two-thirds. There is also rust-bulging along top seam of lower plate.
- Boiler room door has crude replacement hinges welded on and plating is rusted through.
- Vertical strap No. 6 is bulged slightly in three places.
- Vertical strap No. 7 is severely rust-bulged along entire length.
- Radio room door is rusted through in two corners.
- Vertical strap No. 8 is badly bulged behind davit.
- Vertical strap No. 9 is slightly bulged along entire length.
- Cabin door is slightly bulged around whole perimeter.
- Vertical strap No. 10 is severely bulged in three places.
- Boundary angle is severely bulged away from lower house plate for a distance of approximately 5'. This area lies beneath the boat deck scupper pipe.
- Vertical strap No. 11 is severely bulged at the base.
- Cabin door is rust-bulged all around and has a corrosion hole near bottom.
- Vertical strap No. 12 is bulged along lower third behind davit.
- Lower plate has a 4" flat bar doubler for a length of 8' over a badly bulged boundary angle. This indicates corrosion behind the doubler.
- Vertical strap No. 13 is bulged along the lower third.
- Engine room door is rust-bulged around the perimeter.
- Vertical strap No. 14 is badly bulged along the lower half; deep pitting is evident behind. Top strap is detached from rivets over engine room door.
- Vertical strap No. 15 is rust-bulged along lower half: a welded doubler patch has been fitted on the house side adjacent to strap.
- Vertical strap No. 16 is in good condition, but the boundary angle in this location is completely rusted away under a boat deck scupper pipe.
- Boundary angle is considered ineffective for the whole length of the engine room due to severe corrosion, rust-bulging, and deep pitting of lower plate. Rivets in the deck flange are missing.
- Frames are bulged off of the side plating behind the engine room paneling.
- Vertical strap No. 17 is rust-bulged in three places.
- Head door is rust-bulged around perimeter; side plating is bulged away from door frame stiffeners.

- Vertical straps No. 18, 19, and 20 are rust-bulged in three places.
- Frames in way of the towing engine room are detached from the side plating due to rust-bulging inside.
- Lower plate of the house is waved about 1/2" for most of its length.

Deckhouse, Starboard Side—Reading from fore to aft

- Deep pitting is seen behind the steering chain cover.
- Galley door lower plate is rusted through around rivets.
- Vertical strap No. 3 is rust-bulging at bottom 6".
- Vertical strap No. 4 is rust-bulging along lower half.
- Stairwell to boat deck is severely wasted along top strap; side plating is adrift from frame.
- Vertical strap No. 5 is welded along forward edge, but bulged between rivets on after face.
- Vertical strap No. 6 is rust-bulged between rivets along entire length.
- Boiler room door; upper half is intact, lower half is slightly distorted by rust.
- Vertical strap No. 7 is severely rust-bulged between rivets.
- Lower house plate is heavily scaled and rust holes are seen below the boat deck scupper pipe. Aft of this hole there is a 10" x 54" doubler in way of a cabin door and davit socket indicating a wasted area behind the doubler.
- Vertical strap No. 8 has a slight bulge along the lower third.
- Bosun locker door is wasted along lower edge.
- Forward and after davits appear to be frozen at their socketed bases.
- Top strap is heavily scaled in way of the davit bracket.
- Cabin door, top and bottom edges rust-bulged.
- Vertical straps Nos. 11, 12, 13, and 14 are each rust-bulged in two places.
- Chief Engineer's cabin door is rust-bulged around the frame.
- Engine room door lower plate is severely wasted around the perimeter. The bulkhead plate is adrift from stiffener at the aft edge of the door frame.
- Top strap 4' aft of the davit is rust-bulged and broken out from house side, probably from leakage around mast chainplate in this location.
- Vertical strap No. 15 is in good condition, but the boundary bar is rusted through to the deck plating here.
- Side plating of house and lower plate shows doubler patches and deep pitting. Four frames are separated from the side plating due to rust-bulging.
- Vertical strap No. 16 is rust-bulged along the bottom 6".
- Vertical strap No. 18 is a 19"-wide rolled corner post. It is rust-bulged at the upper corner.

Deckhouse, Aft Bulkhead

- Towing engine room door is a hand-riveted replacement fabricated and installed by volunteers.
- Upper edge of tow wire aperture is wasted and adrift from the frame.
- Boundary angle is heavily corroded and pitted behind the towing bits.

Conclusions: The corrosion seen in the deckhouse is somewhat more severe on the port side. This condition may be due to the unequal weathering of her port side which faces toward the Golden Gate when she is moored at her Hyde Street Pier berth. None of the noted defects are considered serious problems. To prevent further deterioration, a concerted effort should be made to seal all leaks and bulged seams against further ingress of rain water by means of sealants or epoxies.

The long-range restoration plan should include repair of all deficiencies noted in the deckhouse. An in-house riveting capability will need to be developed to properly repair all of the corrosion damage. The "paneled" effect of the vertical straps, and the highly visible facets of the doors and other small features of the deckhouse, are important features of the ship's character and should be maintained. The deckhouse scantlings are light and the repairs can be readily done in segments. This is work which can be carried out at the berth over an extended period, and would be a project well-suited to volunteers.

3-1.5.2. Deckhouse Interior

The compartments in the deckhouse vary in arrangement and condition. They are therefore listed on a room-by-room basis, from fore to aft.

Messroom

Built to the curve of the forward end of the deckhouse, the messroom is sheathed with light tongue-and-groove planking. There is a settee and table forward with a raised wood sole beneath. To starboard is the companionway leading down to the forecabin. Port and starboard are doors opening onto the main deck. A wooden icebox is located against the aft messroom bulkhead, on the port side. The icebox appears in this location in historic photographs from the 1950s.

Condition: The deck has multiple small welded doublers which have rusted through near the forecabin companionway. The boat deck planking above is sound and the overall condition of the compartment is good.

Conclusions: All that will be required for this compartment is painting and furnishing. Further historic research will be needed to determine the original arrangement of the mess.

Galley

The steel deck in the galley is covered with a cement slab which is approximately parallel to water line. The deck level is considerably higher than main deck and is built to clear the forward end of the boiler underneath. The bulkhead between the galley and the messroom is constructed of sheet steel. A wood crockery store is mounted on the bulkhead to starboard. There is a doorway between the two rooms, but no door. The galley has steel dutch doors opening onto the deck, port and starboard. Across the aft bulkhead, which is 3/16" steel plate, are a coal scuttle to starboard and the coal stove with a stove pipe running to the stack. A counter runs athwartship next to the stove, with a built-in sink and hand pump to port. Aft on the port side is a doorway leading aft to the fidley level of the boiler room. The galley is fully functional and used regularly by the volunteer crew.

Condition: There is a heavy buildup of scale between the cement slab and the lower plate of the house side. The interior and furnishings are in good condition, and the stove, sink, and hand pump are in working order.

Conclusions: The cement galley floor will eventually need to be partially removed to arrest corrosion in the house sides.

Boiler Room Fidley

On centerline in this compartment is the steam drum of the boiler and the breeching rising up to the stack. A pipe handrail and cast steel deck grating surrounds the upper works of the boiler. Aft of the boiler, doors open to the main deck port and starboard. To starboard is the athwartship ladder descending into the boiler room. This steel ladder has a rise of 11" and a run of seventeen steps down to the lower grating.

To port is a passage to the galley, to starboard the stairwell to the boat deck is set into the room. The coal bin for the galley is under the stairwell.

The steam pipes run along the overhead. Across the aft end of the boiler room fidley is a 3/16" plate bulkhead with cabins beyond. A door in the bulkhead leads to the port side cabin, and a centerline passageway runs aft, between port and starboard cabins, to the engine room.

Condition: The main deck around the top of the boiler is severely wasted. Deck plating beneath the base of the house is bulged away from the channel iron carlings port and starboard of the boiler. The bottom of the coal locker is rusted through and the plating of the stairwell shows rust-bulging around rivets.

The condition of the overhead around the perimeter of the stack vent is poor. The steel and wood deck beams supporting the stack vent and boat deck across the forward end of the fidley are severely deteriorated due to corrosion and rot. All boat deck plank ends in this area are rotten. The stack vent is rusted through and has been patched with cement.

In the overhead, along port and starboard sides and across the aft end, the lower flanges of the angle beams are rust-bulged down about 3/4" from the wood beams. The wood beams are rotten, as are the plank ends of the boat deck. The joints between the beam sections are packed with rust scale and are assembled with bolts rather than rivets.

On centerline, the rotten planking extends back to the beam across the aft bulkhead. The steel beam here is completely rusted through and the wood portion is rotten. This area leaks when it rains. A temporary repair may be made by means of sealants on the boat deck, but any lasting repair will require renewals. The steel bulkheads fore and aft are in good condition.

Conclusions: The boiler room fidley area is in worse condition than other compartments in the house. This may be the result of the heat generated by the boiler and stack. Major work will be needed to restore the boat deck above. The wasted main deck around the boiler represents a structural deficiency which should be corrected with welded replacement of steel structure.

Passageway from boiler room to engine room

This passage is bounded by longitudinal steel joiner bulkheads port and starboard. There are no doors at either end. Steam piping is suspended overhead, thus reducing headroom. The deck is formed by the riveted steel fuel tank top.

Condition: The steam pipes have had old insulation removed. The second boat deck beam is severely rusted and the wood portion is split and rotten. The third through twelfth beams all show surface rust but both wood and steel are sound. Some of the boat deck planks on centerline are newer replacements.

The steel joiner bulkheads are in good condition. Halfway down the passage is a household-type hollow-core wood door in a wood frame. This is a post-historic addition and is poorly executed. The fuel tank top is covered with welded plate at 7'-6" from the engine room bulkhead. This work is from an earlier repair.

Conclusions: The overhead will require repairs as part of a rebuilding of the boat deck. The steam piping will need to be re-insulated. It is recommended that the wood door and door frame be removed to increase headroom and return the passageway to historic configuration.

Cabins

There are six cabins between the boiler and engine rooms, three on each side of the centerline passageway. No two cabins are the same size and none open into the passageway.

Port No. 1: This cabin has a door into the boiler room fidley as well as one onto the main deck. A doorway has been opened to the next cabin aft by cutting through a wood joiner bulkhead separating the cabins. This modification probably took place late in vessel's working career. Under Western Pacific ownership, the cabin was used as a boatswain's locker. It is currently being used as a ship's office. The words "Certified for Crew's Mess" are stamped in an overhead beam, indicating that the cabin was originally used for this purpose.

Condition: The cabin has been gutted of most furnishings, but was partially restored by volunteers in 1983.

Port No. 2: This cabin was a stateroom and opens onto the main deck only. It is marked "Certified for 2 Seamen."

Condition: The interior is mostly intact but in need of restoration. The main entry into the vessel is now through this cabin and the alarm system is mounted here.

Port No. 3: This cabin opens onto the main deck and also has a door opening into the engine room. It is larger than No. 2 and is furnished with a built-in single berth, hanging locker, and a small washbasin. The cabin is marked "Certified for 2 Seamen."

Condition: Overhead the deck beam ends have been renewed, both wood and steel. There is rust scale packed between the steel and wood all along each deck beam. The deck below the cabin is either a renewal or doubling of the tank top. The lower side plating of the house is completely rusted through just above the boundary bar. The aft steel joiner bulkhead is completely rusted through and disconnected at the bottom. This indicates a potential thin spot in the fuel oil tank top.

Starboard No. 1: This is a small compartment which is marked "Certified for Wireless Operator" and was probably used as accommodations for that member of the crew during the period HERCULES was equipped with wireless. The compartment is now in use as bosun's stores. A small berth is located athwartships on the forward bulkhead.

Condition: The cabin appears intact, but is in rough condition. Restoration is required.

Starboard No. 2: This cabin corresponds to cabin No. 2 on the port side. It has a single berth, but is marked "Certified for 2 Seamen." The second berth was probably removed after HERCULES ended her seagoing career.

Condition: The cabin is generally intact, though in need of restoration.

Starboard No. 3: This was the chief engineer's cabin and is the largest of the deckhouse cabins. It is marked "Certified for 1 Seaman." The cabin is fitted with a washbasin, hanging locker, built-in berth, and has two doors, one into the engine room and one opening onto the main deck.

Condition: Interior is sheathed with tongue and groove planking. The interior face of the house side plating could not be inspected. Outboard ends of all boat deck beams have been renewed with short scarfed pieces of wood that extend about 9" into the cabin. The aft bulkhead is heavily scaled along the lower edge and the tank top is holed under this scale.

Conclusions: The greatest potential liability in the cabins is the possibility that corrosion along the bulkhead boundary angles has holed or at least weakened the tank top in more locations than the one found. A definitive answer will require selected removal of furnishings to scale and inspect rusted areas around the perimeters of the cabins. Other than this problem and repair of the boat deck above, all cabins require only general restoration of bulkheads and interior joinery.

Upper Engine Room

The forward end of the engine room has a walkway about 3' wide running athwartship. This is on the main deck level, at the aft end of the tank top. Port and starboard are doors onto the main deck. The interior perimeter of the engine room within the deckhouse is beautifully paneled in cherry wood.

Two ladders, one port and one starboard, descend to the upper engine room flat. Aft of the engine, to starboard, another ladder ascends to the door to the towing engine room. Inset in the aft port corner of the upper engine room is a small steel compartment for the head.

Condition: The interior bulkheads for the head are rusted through around rivets. The condition of house sides behind the wood paneling is unknown. The paneling has been stripped bare but had been painted a light color at one time. The remainder of the engine room has been described in the preceding section on the hull.

Conclusion: The wood paneling is in need of coating for protection. This should be a bright finish which can withstand the range of temperature and humidity that the engine room may be subjected to. The sides of the house should be inspected and all necessary coating of the steel completed before the wood paneling is treated.

Towing Engine Room

The towing engine room is located at the aft end of the deckhouse and contains the towing engine. There are doors to the main deck, port and starboard, and a square opening for the towing cable in the aft bulkhead.

Condition: The bulkhead to engine room is rusted through at the base and only attached to the deck angle by a half dozen rivets. The lower plates of the house sides are holed by rust along the boundary angle port and starboard (previously noted in the section "3-1.5.1. Deckhouse Exterior"). The interior door to the head is distorted by rust-bulging around the entire frame.

The overhead has been repaired with scarfed wood beam ends, but lower flanges of steel beams are thin and heavily scaled. Wood beams are sound. Deck plating is a quilt-work of doublers. There are no obvious holes, but it is impossible to ascertain true condition until heavy scale is removed.

Conclusions: Preservation of the towing room should include repairs to the forward bulkhead and the sides of the house. This work is not considered a priority at this time. Scaling and coating of all rusting steel should be sufficient to stabilize this area.

3-1.6. Boat Deck

Description: The boat deck is constructed of 1-1/2" thick tongue and groove planks laid over 3" x 3" wood beams which are bolted to 3" x 3" x 5/16" steel angle deck beams. The steel beams are riveted to the house sides, and are located on 24" centers. The deck beams under the pilothouse are 3-1/2" x 6" x 15 lb. steel channel and are welded to the house. These beams were installed in 1941 to support the added weight of the steel pilothouse.

The deck overhangs the perimeter of the deckhouse by about 12" and terminates in an outboard wood stringer through which the handrail stanchions are fastened. There are six scuppers along each side of the deck. The deck was originally canvas covered, but was coated with Arabol (a nontraditional, tar-like substance) at some time in the past. More recently, the deck has been covered with a layer of tar paper and roofing tar in an attempt to reduce leakage.

Condition: Despite efforts to seal the boat deck, it continues to leak in numerous locations. The wood deck structure, already rotten in many areas, is continuing to decay. Approximately two-thirds of the outboard stringer has previously been renewed, but rot was found in several locations, particularly at the scarfs and handrail stanchions. The covering board around the perimeter of the deck appears to be soft due to decay.

Some of the scuppers are plugged with debris and are not allowing the deck to drain completely, thus promoting leakage and decay.

The centerline planking abaft the stack is rotten and springy underfoot. The margin planking around the stack vent and skylight is hollow sounding, indicating rot.

The engine room skylight is non-original, having a welded frame. There is active corrosion along the sides of the skylight and rust holes in the end plates, just over the deck. The base of the skylight is not properly sealed by the roofing material and is leaking. The canvas covering over the skylight was replaced by volunteers, but does not appear to be properly coated and is ripped.

The handrail around the perimeter of the deck is a hollow pipe two-course railing system. The upper course is 33" high and the stanchions are on 40" centers. This rail is rusted through in numerous places and is beyond practical repair.

Conclusions: If not remedied, the leaking deck covering will lead to further deterioration of the deck and structure below. In the short-term, watertightness can be restored by additional patching with roofing material. A proper repair would involve stripping away all the covering materials and renewing rotten planking, margins, stringers, and covering boards. This work would likely require renewal of at least one-third of the total deck area. A traditional looking covering

material more permanent than canvas could be used to extend the life of the deck. If done properly, this would not compromise historic appearance.

Due to leakage and safety concerns, the boat deck is considered a liability at the present time. It is important that the public not be given access to the boat deck until repairs are made to the wasted handrails. In addition to repairs, it may be necessary to increase the height of the handrails in order to insure visitor safety.

3-1.7. Pilothouse

The pilothouse is a welded steel structure which was added in 1941. It has two levels; the lower level contains the captain's cabin, while the upper level houses the helm and is referred to in this report as the "wheelhouse." The steam engine for the steering is located forward of the captain's cabin. Access to the wheelhouse is via a vertical ladder on aft starboard side of the pilothouse.

Condition: The exterior of the pilothouse has recently been painted with a dark red, oil-based finish coat. There are corrosion holes just above the base of the pilothouse, and corrosion is seen under the flashing that runs along the base.

The top of both pilothouse and wheelhouse are covered with the same type of roofing material as on the boat deck. The covering appears to be intact, but the scuppers on both levels are plugged with sandblasting grit. The covering board around the perimeter of the wheelhouse top is very rotten and it is likely that the decking is in a similar state.

On the interior, the lower level is in need of cosmetic restoration but is structurally in satisfactory condition. The wheelhouse is also in satisfactory condition inside. The original steering pedestal, wheel, and telegraph are in place and in good condition.

Conclusions: Overall, the pilothouse is in good condition. The areas of corrosion noted on the exterior, particularly those seen under the flashing along the base of the pilothouse, should be scaled, sealed, and coated. The decking and covering board of the wheelhouse top will need to be replaced. Scuppers should be checked periodically and cleared as needed.

The pilothouse is not original and constitutes the most significant alteration that HERCULES underwent during her working life. In order to return the vessel to her original oceangoing configuration, the present pilothouse would have to be replaced by a replica of the low-profile wood pilothouse she was built with. This work is not essential to the immediate preservation of HERCULES and should therefore be considered a low priority in overall planning for the vessel.

3-1.8. Stack

Description: The stack is approximately 7' in diameter and rises about 30' above the boat deck. The stack is constructed of an inner and outer tube, with welded seams and riveted butts, indicating it is not original but a renewal from some point in the ship's working life. Further evidence of renewal is the difference in pitting between the inner tube (or flue) and the boiler breeching it is riveted to. The inner tube is of 3/16" plate and riveted to the boiler breeching, which provides the primary support. Brackets riveted to inner and outer tubes maintain a space of approximately 12" between the two, and take the weight of the outer tube.

The outer tube is made of four cylindrical sections of 3/16" plate with welded seams and external buttstraps. The stack vent is approximately 10' in diameter and stands 2' above the boat deck. A conical skirt covers the vent and connects vent and outer stack together, thus helping to support the stack. A cover usually kept over the stack has recently been removed for test firing of the boiler.

Condition: The outer stack is rusted through in places under the clamp bands for the whistle's steam pipe, and is deeply pitted around the riveted butts and the flange of the stack skirt. All but the upper 5' of the outer stack has been painted a dark red, but corrosion is still active on the forward side of the stack and around the unpainted upper end. The

stack vent boundary angle on the boat deck is rusted through on the forward and starboard sides and presently patched with Red Hand. The interior surface of the outer stack is in fair condition, showing only moderate corrosion, but no signs of coatings.

The inner stack appears only moderately corroded, except around a joint between two sections about 8' below the top of the stack. Here the stack plating is bulging due to rust scale in the joint.

The vertical access ladder on the forward side of the stack is severely corroded and is considered unsafe. One rung is missing and several others are very nearly rusted through.

The six stack guy wires (3/4" dia. 6x7 wire) are all heavily corroded.

Conclusions: The inner stack appears to be in satisfactory condition overall, though additional inspection will be needed to fully assess condition. Repairs or reinforcing may be needed in areas of local wastage. The wastage seen in the outer stack is of lesser consequence in terms of strength and can be repaired by adding internal stiffening angles to bridge the corroded joints. Anti-corrosive coatings should be used on all surfaces of the outer stack. The access ladder and all six guy wires will need to be replaced. A cover should be placed over the stack during periods when the boiler is not being fired.

3-1.9. Main Propulsion Engine

The main engine is a triple-expansion reciprocating steam engine with a stroke of 30" and cylinders measuring 17", 24", and 41" in diameter. The main condenser is integral with the engine foundation.

Condition: The main engine appears to be complete, with no apparent damage or missing elements. It turns freely and can be manually jacked over without undo force. The cylinder heads have been removed for inspection in the recent past and volunteers report that cylinders and pistons are in good condition. The condenser is presently undergoing a rebuild, including replacement of all copper tubes.

Conclusions: The major components of the engine appear to be in good condition. Prior to operating the engine on steam, all bearings should be opened out and inspected for wear, and all lube oil tubes swabbed out.

3-1.10. Boiler

HERCULES is fitted with a single-ended Scotch (or fire tube) boiler with four combustion chambers. The boiler is presently fitted with four Coen burners. The Builder's plate on the boiler states "Luken Iron & Steel Co., Pa.; TS 60,000; Builders: John H. Dialogue & Son, Camden, N.J."

Condition: The boiler has been largely rebuilt through volunteer efforts over the past few years. Initial pressure tests have been successful and the boiler is now believed to be in generally sound condition. All asbestos insulation has been removed from the boiler and ultrasonic gauging of boiler plating indicates adequate thickness. The following restoration work has been undertaken by volunteers:

- All the fire tubes have been replaced.
- The stay tubes were found to be in good condition, but two were accidentally cut away and were replaced with solid rods welded in place.
- Eighteen stay bolts of the starboard combustion chamber were replaced after several wasted stays let go during a hydro test in 1989. The combustion chamber plating was bulged out as a result of this incident, but was surveyed and judged to be sound. Several of the replacement stay bolts are presently leaking boiler water.
- The boiler saddle flanges have been renewed with welded plate.
- The safety valves were overhauled and set to 125 psi.
- All stop valves have been overhauled.

- Original gauges have been replaced with more modern “reflex” type gauges.
- Burner tips have been replaced with modified tips for burning diesel fuel instead of bunker oil.

Work has also been completed on auxiliary machinery, piping, and valves associated with the boiler. The main and auxiliary steam lines have been hydro tested to 225 psi. and found to be satisfactory.

Conclusions: Restoration of the boiler is nearly complete. Additional work will be needed to bring the boiler to a safe operating condition. This includes repair of wasted boiler saddle flanges, installation of a permanent fuel system, and at least partial insulation of boiler and steam lines. The leaking stay bolts may need to be sealed by welding them to the boiler shell.

3-1.11. Auxiliary Machinery and Associated Equipment

Most of the steam-powered auxiliary machinery aboard the vessel is thought to be original. A few pieces of steam machinery were added over the years. Others were replaced with nearly identical pieces. More recently, a limited amount of electrically-powered equipment has been installed. The following is a list of all auxiliaries presently aboard HERCULES. A notation is given as to the origin of each piece.

3-1.11.1. Air Compressor

Westinghouse steam-driven, single-cylinder, double-action, with air receiver; non-original, installed to charge railcar brakes during period in railbarge service.

Location: Starboard side of engine room.

Condition: Unknown, requires disassembly for internal inspection. Air receiver hydro tested to 250 psi. (normally operates at 90-100 psi.). New valves installed on air lines.

Conclusions: This compressor will not be necessary for operation of the main engine. It nevertheless should be fully inspected and repaired as a preservation measure.

3-1.11.2. Electric Air Compressor

3-1/2 horse power, 220 volts AC, with twin-cylinder compressor piped into steam system and air receiver. Non-historic addition.

Location: Starboard side of engine room.

Condition: Operable.

Conclusions: Belt guard needed on drive belt.

3-1.11.3. Fuel Oil Heaters (2)

Twin vertical heaters; date from ca. 1943 and replaced heaters that were located on the port side.

Location: Starboard side of boiler room, mounted on aft bulkhead.

Condition: Exterior shows moderate corrosion; top flange bolts removed on port heater; internal condition unknown.

Conclusions: Heaters will not need to be made operable if boiler is to be run on diesel fuel as now planned. Heaters should be opened, cleaned and reassembled for preservation.

3-1.11.4. Feed Water Heater

No manufacturer's name, custom installation; original to vessel.

Location: Upper level of engine room.

Condition: Corrosion on exterior, internal condition unknown; possible asbestos under jacket. All high-pressure valves have been rebuilt, flanged pipe connections renewed, new bolts and gaskets installed.

Conclusions: The heater should be tested in operation. Any asbestos should be encapsulated or replaced with non-toxic insulation. This item should be included in an overall asbestos abatement plan.

3-1.11.5. Feed Water Injector

Simplex Type "R"; not original to vessel (HERCULES was originally fitted with Metropolitan injectors) but probably an early replacement.

Location: Starboard side of boiler room.

Condition: Overhauled by volunteers, ca. 1983; 2" overflow line wasted thru; steam line not hydro tested.

Conclusions: Replace overflow line and test in operation.

3-1.11.6. Auxiliary Injector

Schutte and Koerting; used for hot water wash down and auxiliary boiler feed.

Location: On bulkhead at forward end of engine room.

Condition: Overhauled by volunteers, ca. 1983.

Conclusions: This injector should be tested in operation before routine use.

3-1.11.7. Hydrokinetor Pump

Worthington (4-1/2" x 2-3/4" x 4") horizontal duplex pump. Labeled "Shop No. 0807"; original to vessel.

Location: Starboard aft end of boiler.

Condition: Operational, valves set by volunteers.

Conclusions: This pump is required for firing boiler, should be maintained in working order.

3-1.11.8. Fuel Pumps (2)

Worthington horizontal duplex pumps, with duplex suction strainer and numerous valves attached; probably original to vessel.

Location: In boiler room, positioned athwartships forward of aft bulkhead.

Condition: Operational, reportedly rebuilt by General Engineering Company of San Francisco. Exterior needs paint. A diesel fuel line has been connected for test firing of the boiler. Condition of strainer and valves unknown.

Conclusions: The pumps require only general maintenance. Packing glands should be tightened as needed. The strainer and valves should be opened, cleaned, and repaired as needed.

3-1.11.9. Boiler Room Bilge Pump

Worthington horizontal duplex pump; original to vessel.

Location: Boiler room.

Condition: Operational, overhauled by volunteers in 1989.

Conclusions: Require only general maintenance and repacking.

3-1.11.10. Boiler Feed Pump

Horizontal duplex pump (6 x 4 x 7), no name, "162907 x 8."

Location: Lower engine room, to starboard of engine.

Condition: Operational, no restoration done; exterior shows corrosion.

Conclusions: Needs cleaning and coating; required for operation.

3-1.11.11. Fire and General Service Pump

Worthington (10 x 6 x 10), "302, 416"; probably original to vessel.

Location: Lower engine room, to starboard of engine.

Condition: Operational; liquid end of pump has been rebuilt, steam end has not been internally inspected. Suction line (copper) is holed; discharge line to condenser removed and in process of repair, main condenser line not connected; bilge suction valve overhauled, sea suction valve not operating; fire line hydro tested to 126 psi.

Conclusions: All work in progress should be completed, and pump maintained in operating condition. The sea suction valve should be overhauled during drydocking.

3-1.11.12. Vacuum Pump

Engine driven beam pump; original to vessel.

Location: Integral with engine.

Condition: Unknown.

Conclusions: Inspect as part of engine reactivation.

3-1.11.13. Beam Pumps: Feed Pumps (2) and Bilge Pumps (2)

These four pumps are driven off the main engine and are probably original equipment.

Location: Integral with engine.

Condition: Internal condition of the pumps is unknown; elements have been overhauled by volunteers; new valve installed on aft bilge pump, valves rebuilt on aft feed pump and both forward pumps.

Conclusions: Prior to operation of the main engine, these pumps should be opened up, inspected internally, and cleaned and repaired as needed. The beam bearings should also be inspected.

3-1.11.14. Main Circulating Pump

Centrifugal pump (6" x 6") driven by single-cylinder vertical steam engine. No information on engine; probably original equipment.

Location: Engine room, to port of engine.

Condition: Engine has been opened up and inspected by volunteers, condition reported as good; pump opened and found to be severely corroded internally; repaired with Red Hand epoxy.

Conclusions: Further repairs to the pump are required if it is to be made operational.

3-1.11.15. Condenser

Location: Integral with main engine.

Condition: All copper tubes have been replaced by volunteers. Several cracks are seen in the casing, with evidence of old repairs; tube sheets show cracks and damage to ferrule threads; end plates have been repaired using Red Hand epoxy. The condenser has been reassembled and hydro tested.

Conclusions: The condenser should be tested in operation and checked for signs of leakage through tubes sheets and ferrules.

3-1.11.16. Steam Reciprocating Generator

Generator: General Electric "Continuous Current Generator, No. 145703, Type MP-6-7.5-550, Form 'G', Amperes 67, Speed 550, Volts No Load 110, Full Load 112."

Engine: General Electric single-cylinder, "No. 3787, Speed 550, Size 5 x 4-1/2, Capacity 7.5 Kw., Form 'D'." Original to vessel.

Location: Upper level of engine room, starboard aft.

Condition: External condition appears fair, internal condition unknown. Has been tested on compressed air in recent years.

Conclusions: To avoid possible damage, the engine and generator should be thoroughly checked out before testing in operation. Restoration to operating condition is recommended for interpretation.

3-1.11.17. Steam Turbine Generator

Manufactured by Pyle-National Company, Chicago; "Record No. 17." This generator is standard railroad equipment and was probably added during the railbarge towing era. It produces 27 volts DC current.

Location: Upper level of engine room, starboard aft.

Condition: External condition good, internal condition is unknown. Has been tested on compressed air in recent years.

Conclusions: Operational tests should be conducted and repairs made as needed (use will probably be limited to interpretive display).

3-1.11.18. Atmospheric Drain Tank

A new welded fabrication; original tank has been removed.

Location: Upper level of engine room, port side.

Condition: New tank is installed and ready for operation.

Conclusions: Drain tank should be properly coated before use.

3-1.11.19. Hot Well Tank

A new welded fabrication; original tank has been removed.

Location: Port side of main engine.

Condition: All new construction; inlet and outlet valves have been rebuilt; tank is installed and ready for operational testing.

Conclusions: Tank should be properly coated before use.

3-1.11.20. Lube Oil Reserve Tank

Location: Engine room, starboard forward side.

Condition: Appears in good condition, contains oil and is not leaking. Sight glass is broken, drip pan and lines to spigot are missing.

Conclusions: The lube oil reserve tank is essential to operating the main engine. The tank should be drained and cleaned, and all broken and missing elements replaced.

3-1.11.21. Cylinder Oil Tank

Fifty-five gallon drum, used for main engine cylinder oil; not original to vessel.

Location: Engine room, starboard side forward.

Condition: Unknown, exterior appears in good condition.

Conclusions: Clean out and replace missing elements. Test for leaks.

3-1.11.22. Main Sea Suction and Discharge Valves

Large cast-iron thru-hull valves connected to main circulating pump to supply cooling water to condenser.

Location: Port side of engine room.

Condition: Reported to have been overhauled during 1982 drydocking.

Conclusions: Condition is uncertain, inspect and overhaul as needed during upcoming drydocking.

3-1.12. Piping Systems

HERCULES has several distinct piping systems, including: steam, compressed air, feed water, potable water, fire and bilge, fuel oil, and lube oil. Most of the piping is confined to the boiler room and engine room.

Condition: Much of the piping was visually inspected during survey and deficiencies were seen. Condition can only be fully assessed through testing. The piping for fuel oil and lube oil appears to be in generally fair condition. Wastage was seen in some of the potable and feed water piping, and particularly in the piping used for seawater, such as that for bilge and fire, and circulation water for the condenser. The main and auxiliary steam lines has been hydro tested, as have many of the smaller steam lines to the auxiliary machinery.

Conclusions: The best treatment for the piping is to test and replace it as needed. Original piping that is not to be activated should be kept in place and preserved to maintain historic integrity. Any piping that is removed should be documented. A major question remains as to the condition of the main steam line. This is a copper alloy pipe which carries steam from the boiler to the engine. Although it has been hydro tested, there is concern that it may have become brittle during years of service and may be susceptible to fracture. Such concerns are usually dealt with by annealing the pipe. This would be a major task as it would require the removal of long sections of large diameter piping. There would also be a risk of damaging the piping. An investigation should be made into the possibility of testing the steam line for brittleness without removing it.

3-1.13. Electrical Systems

The shipboard electrical system is a combination of original equipment and later generations of added equipment and wiring. Existing elements of the original system include a steam reciprocating generator, which produced 110 volts DC, and an electrical panel with exposed knife switches, both located at the starboard aft end of the engine room. There is also a steam turbine generator which was added in the later working period. The origin of much of the existing wiring and fixtures is not known. The operational electrical system in use today consists of a shore power cable providing 240/120 volt AC current for lighting, service outlets, bilge pumps, power tools, and an electric air compressor. A main disconnect switch and circuit breaker panels are located at the aft end of the engine room. Two additional circuit breaker panels located in the crew's mess control the circuits in the forward end of the vessel.

Condition: The two shipboard generators have been tested, but are not considered fully operational. The active wiring and fixtures vary in condition and quality, but are marginal at best. The majority of the wiring is run in 1/2" and 3/4" conduit. Most of the fixtures are marine grade bronze junction boxes and protected light fixtures. The conduit and marine fixtures are of a type which was common between the 1930s and 1960s. More recently, armored-type marine grade cable has been added in several compartments. The cable is of a suitable type, but has not been properly secured. Temporary wiring installations have been made to facilitate restoration work in the engine room, boiler room, and forecabin. This includes non-armored cable, open light fixtures, and household-type service outlets. None of this work is suitable marine service.

Conclusions: In general, the wiring system is considered a liability. The temporary installations may be useful in the short-run, but are not suitable for service in a marine environment. It is recommended that a completely new shore power and ship board system be installed. This system should be designed to meet the future needs of the vessel as a museum ship and as an operating vessel. Although not all portions of the system need be installed initially, they should be included in the design. Selected portions of the existing marine grade system might be retained and used. The historic generators and the switch panel should be restored for display purposes.

3-1.14. Deck Machinery and Equipment

3-1.14.1. Windlass

The windlass is located abaft frame 8 on the main deck. It was originally fitted with wildcats for chain cable, and two warping drums for hawser. There was a provision for manual operation by means of a crosshead and pump brakes. Primary power is provided by a two-cylinder, horizontal v-drive steam engine located on the t'ween deck. Transmission is through a vertical drive shaft and worm gear.

Condition: The windlass was repaired to working condition during the shipyard period in 1982. Work included repair of a crack in the foundation casting. The steam drive engine has reportedly been run on compressed air. The wildcats, clutches, brakes, and manual power system are all missing; only the warping drums remain. The bed plate of the windlass sits on a wood pad of what appears to have been 2-1/2" stock. This pad is now rotten, and water running underneath has caused corrosion. The winch engine appears to be partially disassembled. The steam lines are disconnected and a compressed air fitting installed.

Conclusions: The wood pad beneath the windlass should be replaced. The winch engine should be inspected and tested, and all steam lines hydro tested. Long-term planning should include acquiring or fabricating the missing elements of the windlass.

3-1.14.2. Towing Engine

Manufactured by Chase Machine Company, Cleveland, Ohio. Consists of a large athwartship wire drum, horizontally mounted, and driven by a pair of single-cylinder steam engines mounted on a common foundation. Original equipment.

Location: Mounted in a room at the aft end of the deckhouse.

Condition: The engine was freed up and test operated on compressed air, and the historic automatic tow wire attachment reinstalled by volunteers in 1977. Paint on the exterior of the winch and engines is beginning to break down, with resultant corrosion. Internal condition is unknown. A deteriorated tow wire of unknown length is still spooled on the drum. The machinery appears complete and intact but in need of preservation.

Conclusions: A functional towing winch is not essential to the operation of HERCULES, but is a highly significant element and should be preserved and interpreted. At a minimum, this equipment should be coated with preservative film and covered with a tarp to arrest corrosion until such time as restoration can be undertaken.

3-1.14.3. Capstan

Steam-powered capstan driven by a two-cylinder steam engine with power transmitted through a worm gear and vertical shaft.

Location: On the port side, next to the towing bits and abaft the deckhouse. The horizontally mounted engine is located in the shop on the t'ween deck level of the engine room

Condition: Unknown. The entire assembly appears intact and functional, and has reportedly been run on compressed air in recent years.

Conclusions: Test in operation, repair as needed. All steam lines should be hydro tested before an attempt is made to operate the capstan.

3-1.14.4. Bitts

Bow bitt

Single post bitt with athwartship crossarms. This is a heavy casting with a round, flaring base bolted through the deck plating. An anchor davit is set in the top of the bitt; original equipment.

Location: On centerline, approximately 6' aft of the bow.

Condition: Water runs past the davit and fills up the base of the casting, possibly corroding the deck plate. The bolts may be wasted above the deck plate, but cannot be inspected without removal. The davit is a replica fabricate and installed during museum period. It now appears to be frozen.

Conclusions: The bitt should be lifted for inspection and repair of the deck plate. A scupper should be drilled in the casting and grout poured in the base up to the scupper level to facilitate drainage. Efforts to free up the davit should be made without excessive use of heat or force which might damage the davit or bitt.

Fore Bitts, Port and Starboard

"H" configuration; posts stand 45" high, are 12" in diameter at top, and are on 28" centers.

Location: At the forward end of deckhouse.

Condition: Unknown where post are encased by wood caprail, good where visible.

Conclusions: Bitts should be inspected in way of cap rail before a strain is put them.

Tow Bitts

"H" configuration; posts stand 66" high, are 11" in diameter, and are on 44" centers.

Location: On centerline immediately abaft the deckhouse, mounted athwartships.

Condition: Bitts appear in good condition but deck plate is severely pitted and corroded underneath.

Conclusions: All corroded areas should be sandblasted and coated. Repairs to deck plate should be considered if bitts are to be subjected to heavy loading.

Aft Bitts

"H" configuration bitts; posts stand 32" high, are 12" in diameter, and on 26" centers.

Locations: On centerline, aft of towing bitts.

Condition: Bitts are in good condition, but the deck plate is badly corroded underneath.

Conclusions: All corroded areas should be sandblasted and coated. Repairs to deck plate should be considered if bitts are to be subjected to heavy loading.

3-1.14.5. Steering Gear

The steering system consists of a steam steering engine connected by chain-drive to the main deck level, and by rod linkage back to chain at the rudder quadrant. The linkage is under cover and mounted in guides the length of the deck.

Location: The steering engine is in the lower level of the wheel house. The original brass steering pedestal and wheel is mounted in the wheelhouse.

Condition: The steering engine appears to be in good condition. The covers over the chains on deck were recently removed and the chain guides cleaned of debris and rust scale. Wastage of the house sides was seen where the cover are bolted to the house. The steering pedestal and wheel are in excellent condition.

Conclusions: Even if HERCULES is not steamed the steering system, including engine and linkages, should be inspected and overhauled as a preservation measure. The rudder bearings should be inspected during drydocking.

3-1.14.6. Ventilators

The water tanks are vented by 2" pipes under the bulwarks at the sides.

The forecastle has two 8" diameter cowl vents, port and starboard, at the foreword end of the deckhouse. The cowls for the vents are secured to the overhang of the boat beck. The starboard vent goes through a doubler in the main deck, which is heavily corroded at the base of the vent. The vents are in fair condition and should be overhauled by cleaning and lubricating the bases. Hoods should be provided for keeping rain out of the vents.

The boiler room has one 20" diameter cowl ventilator on the boat deck, to port of centerline (there was originally an identical one to starboard). The rotating gear is missing and the vent is rusted through in several places. There is no provision for a screen or hood and this vent freely admits rain to the boiler room. This ventilator should be rebuilt and provision made for a rain hood.

The fuel oil tank vents are 5" pipe located on the boat deck abaft the stack, one port and one starboard. The starboard vent is rusted through. Both vents are missing their flame arrestor screens. The vents should be restored to their original appearance but will not need to be functional if the main tanks are no longer used for fuel.

3-1.14.7. Boats and Davits

The lifeboat and skiff have been removed to the Museum small craft storage area near the Hyde Street Pier.

Work Skiff: Flat-bottomed, hard-chine wood skiff (13'8" length, 4'9-1/2" beam, 17" depth). The original is fit for indoor display only. The Museum boatbuilding program has recently produced an exact replica. There are presently no chocks for this boat on the boat deck, it may originally have been kept in the davits.

Lifeboat: Galvanized metal, riveted lapstrake, with a wood stem, keel, sternpost, and thwarts (20' length, 6' beam, 3' depth). Flotation tanks at the ends are of unknown integrity. The bottom is rusted through along the garboard, as is the sheer strake to port of the sternpost. The lifeboat dates from 1909 and is considered significant, even though it may not be one of HERCULES' original boats. Restoration will require renewal of the garboard plating and the wood backbone.

The chocks for stowing the lifeboat on the boat deck are moderately rotten and should be renewed.

Starboard Davits: Radial type, 3-3/4" solid bar, socketed on lower sides of deckhouse. These are interesting in that they are designed to cant outboard. The davits show some corrosion at the lower ends, but are otherwise in good condition. The davit tackles, consisting of 8" double blocks with the wood shells, have been rigged down and are laying on the boat deck. The shells of the blocks are cracked and the manila falls are rotten. It is not known whether the blocks are of the original type. For a boat of this weight, a much safer arrangement would be triple blocks. The double blocks may have provided adequate purchase for a brawny tugboat crew, but would have been dangerous and unpleasant enough to use, particularly in a seaway. These tackles should not be used for lifting until the rotten manila falls are renewed.

The span and guy wires are severely corroded and should be renewed. At present there are no guy tackles, and these may never have been rigged. To swing the davits with a small crew, a tackle needs to be rigged.

Port Davits: These are smaller than the starboard davits and are not original; early photographs show the vessel with equal height davits port and starboard. Like the starboard davits, these are designed to cant outboard. The davits are adequate to handle the work skiff but not a lifeboat. The forward davit has been bent above the boat deck bracket.

3-1.15. Radio and Navigational Gear

The ship was not fitted with wireless as original equipment but was so equipped later in her career. The wireless equipment was located in two small wooden shacks on the boat deck, one for the radio, and the other for battery storage. There is no trace of these structures on the boat deck today, and they were reportedly removed as early as 1924. A small cabin on the starboard side of the deckhouse provided accommodations for the operator during this period. This space is not presently restored. More modern radio gear was installed later in HERCULES' career, and may have been located in the wheelhouse.

Running lights were formerly mounted in boxes on top of the pilothouse, but have been removed in recent years. Their location is not known.

Aside from restoration of a historic radio room, any plans to operate the vessel should include outfitting with functional navigation and safety equipment including VHF radio, running lights, horn, and compass. In addition, the following equipment is recommended: loud-hailer, spotlight, and hand-held VHF. Additional safety gear will also be required per U.S. Coast Guard regulations.

3-1.15.1. Brow (Gangway)

The present brow arrangement is not designed for public access and is only marginally suitable for volunteer and staff access. If HERCULES is to remain at Lower Fort Mason for an extended period, safety improvements should be made to the existing brow.

3-2. Ultrasonic Survey of Hull Thickness

3.2. Ultrasonic Survey of Hull Thickness

The following is a record of ultrasonic gauging of the steel hull and bulkheads of steam tug HERCULES. Initial measurements were recorded in 1987 and updated during survey in 1989. All gauging was performed from the hull interior using a T-Mike ultrasonic caliper manufactured by StressTel. The method employed was to take a band of gaugings around the transverse section of the shell in each compartment. Additional readings were taken in suspect areas where heavy interior corrosion was evident. A horizontal band of waterline gaugings was omitted from the survey, as it would not reveal the condition of the external doubler plates in this area.

Although the ultrasonic survey will not provide a detailed assessment of hull condition, it is considered a reliable indication of overall wastage.

Forepeak, between frames 4 and 5

	<u>Port</u>	<u>Starboard</u>
Strake: Garboard, A	- .326	.318
B	- .409	.366
C	- .276 behind dblr.	.125 behind dblr.
D	- .349	.425
E	- .316	.415, (fr. 2 .420)
F	- .389 (fr. 5-6)	.390, shell insert

Collision Bulkhead, frame 8, to port of centerline

bottom plate	- .415
2nd "	- .214, .253
3rd "	- .247
4th "	- .258
5th, top "	- .237

Fore Hold, between frames 19 and 20

	<u>Port</u>	<u>Starboard</u>
Strake: Garboard, A	- beneath cement, no readings possible	
B	- .370, (fr. 22 .260)	.337
C	- .245 (@ land of D)	.400
D	- .243	.300
E	- .292	.320
F	- .389, .346	.357
Sheer, G	- .253 (beneath guard)	.336
		.207 (beneath guard)

Boiler Room, between frames 28 and 29

	<u>Port</u>	<u>Starboard</u>
Strake: Garboard, A	- beneath cement, one reading	.454, at fr.31
B	- " "	
C	- " "	
D	- .330	.116, .118 (behind blow-
E	- .423, .380, .323	.151 down pipes)
F	- .397 (top of strake)	.314
	.249 (beneath guard)	
Sheer, G	- .482 (mid-strake)	.438
	.367 (beneath guard)	

Port Fuel Oil Tank, between frames 42 and 43

Strake: Garboard, A	- beneath water and sludge, no reading
B	- .320 (after deducting .150 for oil film)
C	- .289 " " " " " "
D	- .184 " " " " " "
	.230 " " " " " "
E	- .240 " " " " " "
F	- .265 " " " " " "
	.250 " " " " " "
(behind dblr)	.149 " " " " " "
Sheer, G	- .300 " " " " " "
between fr. 48-49 E	- .365 (after deducting .030 for oil film)
	.296 " " " " " "
	.378 " " " " " "
Floor web at fr. 42	- .252 (on clean metal)
	.267 "

Bulkhead at fr. 51, between center bulkhead and swash plate

bottom plate	.435
2nd "	.272
3rd "	.376

Starboard Fuel Oil Tank, between frames 43 and 44

Strake: Garboard, A	- beneath sludge, no reading
B	- .351
C	- .398, .377, .333
D	- .294
E	- .332
F	- .375, .405
G	- .500, .418, .412
Between fr. 38-39 D	- .392
E	- .343
F	- .345

Oil Tank Centerline Bulkhead, between frames 42 and 43

bottom plate	.333
2nd "	.255
3rd "	.253

Engine Room (readings taken where access to hull was available)

Port, between fr. 54-55, strake G	.420	
	.406	(beneath Guard)
	F - .272	
	E - .303	
between fr. 55-56,	D - .336	
	.254	(in way of dent)
between fr. 52-53,	D - .281	
between fr. 51-52,	C - .168	(beneath circ. pipe)
	B - .125	
	A - .297	
between fr. 59-60,		(plate severly wasted at seam between C and D, no reading possible)
between fr. 60-61	C - .170	
	.132	
between fr. 61-62	E - .234	
between fr. 66-67	C - .246	
between fr. 67-68	C - .306	
between fr. 68-69	D - .323	
	C - .298	
	B - .375	
Stbd, between fr. 55 and 56	E - .358	
	.197	(smooth interior shell indicates wastage on outside)
between fr. 52-53	D - .340	
	.211	
between fr. 59-60	D - .283	
	E - .310	
between fr. 60-61	C - .252	
	D - .239	
between fr. 67-68	B - .146	
	C - .190	
	D - .300	
	E - .242	

Note: The most severe areas of corrosion seen in the engine room were below the platform gratings, just above the line of the bilge cement, and behind piping. There is up to 5/8" of scale between the cement and the shell, and the entire bilge area below the cement is suspect. A more thorough survey of the engine room bilge is needed but will not be practical until extensive cleaning is done. A pump and leak stopping material should be on hand if any serious scale removal is attempted while the vessel is afloat.

Aft Peak Tank; between frames 72 and 73

	<u>Port</u>	<u>Starboard</u>
Strake: Sheer, G	- .437	.347
	.340 (beneath guard)	.289 (beneath guard)
		.318 fr. 74-75
F	- .191, .219	.317
		.254 fr. 74-75
E	- .345	.293
D	- .330, .250	.297
C	- .322	.282
B	-	.518 fr. 74-45

Floor web at frame 75 - .363

Lazarette Tank

	<u>Port</u>	<u>Starboard</u>
Forward of Transome		
fr. 77-78	G - .329	
fr. 78-79	G - .317	.328
	F - .227	.329
	E - .229	.243
	D - .262	
Aft of Transome		
	G - .130	
	F - .321	.300
	E - .334	.273

Bulkhead at frame 77, on centerline

bottom plate .166
top plate .299

Rudder Trunk .459

3-3. BIBLIOGRAPHY

3-3.1. Physical History References

For ease of reference, all sources cited for the physical history are listed with the citations in the Chronology of Physical History. The majority of these sources were obtained from the Historic Documents Department of the San Francisco Maritime National Historical Park in San Francisco, California. Material includes published works, photographs, Museum correspondence, ship's logs, and records of work kept by the maintenance department, contracts, and invoices for work performed. The reliability of the sources varies. A rating of reliability is therefore given with each reference.

3-3.2. General References

Architectural Resources Group. 1987. *Hyde Street Pier Concept Plan*. San Francisco.

Brouwer, Norman. 1985. *International Register of Historic Ships*. Annapolis: Naval Institute Press.

Dring, Harrison. Historical Papers. [In Process] San Francisco Maritime National Historical Park. San Francisco.

Interpretive Prospectus. Harper's Ferry: Division of Interpretive Planning.

National Park Service. 1980. *General Management Plan, Golden Gate National Recreation Area/Point Reyes National Seashore*. Washington D.C.: U.S. Government Printing Office.

_____. 1985. *Cultural Resources Management Guideline, NPS-28, Release No. 3*. Washington D.C.: U.S. Government Printing Office.

_____. 1989. *Secretary of the Interior's Standards for Historic Vessel Preservation Projects with Guidelines for Applying the Standards*. Washington D.C.: U.S. Department of the Interior.

Nautical Gazette. 6 February 1908. "Two New Dialogue-Built Tugs for Service on the Pacific Coast." New York.

Office of the National Register. 1987. *Code of Federal Regulations, Title 46, Parts 41-69, Marine Engineering*. Washington, D.C.: U.S. Government Printing Office.

Tri-Coastal Marine. 1988. *Cultural Resources Management Plan for the Fleet of Historic Ships of the Golden Gate National Recreation Area*. Galveston.

Credits

Project Manager: Don Birkholz, Jr.

Historical Research: David Canright

Vessel Survey: Don Birkholz, Jr. and Walter Rybka

Structural Drawings: Michael Strange

Mechanical Drawings: Bruce Hellman

Ship's Lines: David J. Seymour

Graphics Production: David Canright

Document Design and Layout: Stephen Horton

NPS Production: Lynn Cullivan

Special Thanks:

Harry Morgan and the HERCULES Volunteers for assistance in Survey and Documentation.

Chris Hoskins for historical material.

Historic Documents Department and J. Porter Shaw Library, San Francisco Maritime NHP.



As the nation's principal conservation agency, the Department of the Interior has responsibility for most of our nationally owned public lands and natural and cultural resources. This includes fostering wise use of our land and water resources, protecting our fish and wildlife, preserving the environmental and cultural values of our national parks and historical places, and providing for the enjoyment of life through outdoor recreation. The department assesses our energy and mineral resources and works to ensure that their development is in the best interests of all our people. The department also promotes the goals of the Take Pride in America campaign by encouraging stewardship and citizen responsibility for the public lands and promoting citizen participation in their care. The department also has a major responsibility for American Indian reservation communities and for people who live in island territories under U.S. administration.

