



29.86/4:AQ 3

Clemson University



3 1604 019 774 340



*Aquatic Park  
San Francisco*

*Jan 96  
Radwood Empire Assn. P*

# CULTURAL LANDSCAPE REPORT AQUATIC PARK

SAN FRANCISCO MARITIME NATIONAL HISTORICAL PARK



ADDITIONAL DOCUMENTS & PHOTO ITEMS  
AUG 03 2010  
CLEMSON LIBRARY

8-17-20  
10-01



**CULTURAL LANDSCAPE REPORT, AQUATIC PARK**  
**SAN FRANCISCO MARITIME, NATIONAL HISTORICAL PARK**

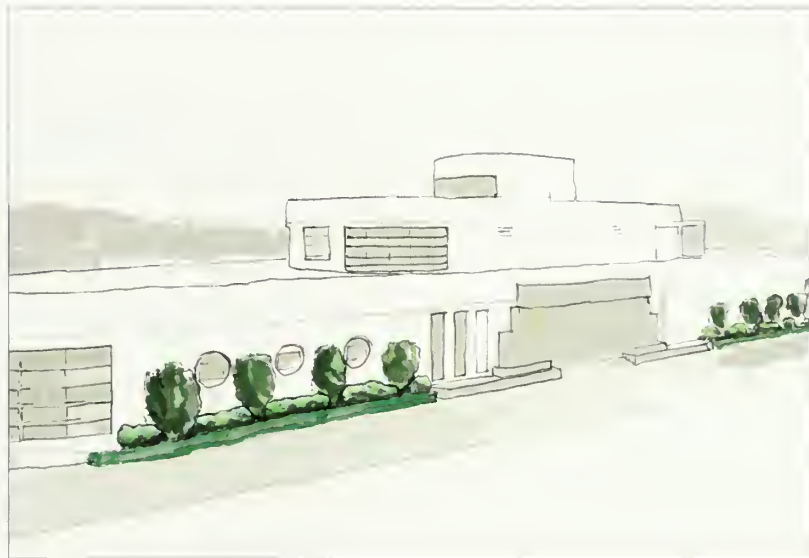

**NATIONAL PARK SERVICE**  
**PACIFIC WEST REGION**  
**2010**



Digitized by the Internet Archive  
in 2012 with funding from  
LYRASIS Members and Sloan Foundation

<http://archive.org/details/culturallandscap00sanf>



# CONTENTS

<b>Introduction</b>	<b>1</b>
Management Summary	1
Historical Overview	2
Scope and Methodology	5
Study Boundary	6
Endnotes	8
<b>Site History</b>	<b>9</b>
Pre-Contact Landscape	9
Spanish and Mexican Period	9
19th-Century Site Development	10
Park Design and Development	12
Works Progress Administration	19
Construction of Aquatic Park	24
Military Use	31
Multiple Use Public Park	33
National Park Service	41
Historic Base Map	45
Endnotes	47
<b>Existing Conditions</b>	<b>53</b>
Existing Conditions Map	59
<b>Analysis and Evaluation</b>	<b>61</b>
Introduction	61
Topography	61
Buildings and Structures	65
Circulation	78
Vegetation	83
Endnotes	91

<b>Treatment</b>	<b>93</b>
Introduction	93
Historic Design Character	94
Documentation for Treatment	97
Cultural Landscape Management Zones	98
Treatment Plan	101
<b>Recommendations</b>	<b>103</b>
Core Area	103
Buildings and Structures	104
Circulation	115
Vegetation	127
Pocket Park	148
Small-scale Features	150
Victorian Park	153
Vegetation	155
Circulation	159
Small-scale Features	160
Treatment Plan	161
Bocce Ball Courts	163
Endnotes	164
<b>Selected Bibliography</b>	<b>165</b>
<b>Appendices</b>	<b>175</b>
A. Treatment Workshop, Aquatic Park Cultural Landscape Report, April 25, 2007	
B. Summary Statement of Significance and List of Contributing Resources, Aquatic Park, San Francisco Maritime National Historical Park	
C. Skateboard Deterrences	
D. Edge Treatments for Paving and Landscape Areas	
E. Landscape Layout Plan, 1.0 (January 3, 2008)	
F. Selected Aquatic Park Drawings on file, National Park Service, Pacific West Regional Office, Oakland, California	

# INTRODUCTION

## Management Summary

Aquatic Park is a historic designed landscape located on the San Francisco Waterfront, immediately west of Fisherman’s Wharf. The park is within the San Francisco Maritime National Historical Park (SAFR) and has a rich association with maritime history, community and park planning, and the Works Progress Administration. For over a century Aquatic Park has been a popular public recreation area and waterfront park.

The designed landscape of Aquatic Park includes historic circulation systems, open spaces, planted areas, and several significant structures including piers, retaining walls, unique outbuildings, and the Streamlined Moderne Bathhouse. In 1984, Aquatic Park was listed in the National Register of Historic Places and three years later, in recognition of its national significance, the park was designated a National Historic Landmark (NHL). The period of significance for the historic district is between 1920, when initial construction of the park began, through 1945, marking the end of World War II and military use of the site.

Although stabilization work related to preservation of significant historic structures, museum collections, and other park resources has occurred, specific treatments for preservation and rehabilitation of the historic designed landscape comprising Aquatic Park have been limited. The primary document setting the framework for treatment of the landscape is the park’s *General Management Plan* (GMP). As defined in the GMP, Aquatic Park is within the park-wide *Cultural Zone* where development “. . . must be compatible with preservation and interpretation of cultural values.” Within this relatively broad management zone, Aquatic Park itself is within a *Cultural Subzone* where “preservation, adaptive use, and commemoration” are appropriate treatments.<sup>1</sup>

While the GMP provides the framework for managing the historic district, the park lacks specific guidance for maintaining the grounds and treating historically significant landscape resources. This lack of guidance has the potential to affect the integrity of the NHL district as a whole. For example, some landscape maintenance practices undertaken

to address park security or safety concerns, such as adding, replacing, or removing plant materials, may be incompatible with the historic character of the park and designed landscape. In addition to the lack of guidance for treatment of the historic landscape, the park is engaged in several planning projects that also have the potential to affect the NHL. Some of these projects include:

- A proposed extension of the historic streetcar from Fisherman’s Wharf to San Francisco Maritime NHP and Fort Mason, routing through Aquatic Park. This will potentially require the addition of new structures, utilities, and circulation systems, creating new physical and visual impacts within the district.
- A new park GMP (2011) that will address potential changes to the western portion of Aquatic Park and lower Van Ness Avenue, and a new GMP for Golden Gate NRA that will consider the possible use of Pier 4 for the Alcatraz Ferry.
- The development of a new sign and exhibit plan that will include interpretive and way-finding signs located throughout the NHL district.
- The intent to improve ADA compliance throughout the park that, in turn, has the potential to effect historic circulation patterns and features.

The purpose of the Cultural Landscape Report for Aquatic Park is to provide treatment recommendations for the preservation and rehabilitation of the historic designed landscape within the framework of contemporary park operations, compatible adaptive use of the grounds, and sustainability.

## Historical Overview

Landscape architect Frederick Law Olmsted first advocated the idea for an aquatic park at Black Point Cove in 1866. In 1905, architect and urban planner Daniel Burnham suggested that the site serve as a “bay shore park” with a yacht harbor and rowing and swim clubs nearby. Although neither plan was adopted, by 1909 community groups were campaigning to have the area set aside for a public park and in 1917, the San Francisco

Board of Supervisors authorized purchase of land around the cove. In 1920, the city graded the land between Larkin Street and Van Ness Avenue. In anticipation of the construction project, the city hired 22 men in 1931 to grade the shoreline area below Beach Street. Construction of a Municipal Pier began that year and was completed by mid-1933, with the concrete curbing, benches, and parapet wall on the pier completed in March 1934. It soon became evident that the cost to construct the park far exceeded available city funds. Work on the park came to a halt until 1935 when the Works Progress Administration (WPA) began a four-year project to construct an aquatic park at Black Point Cove.

Initial development by the WPA focused on stabilizing the shoreline and excavating the foot of Polk Street for construction of the Bathhouse. The WPA went on to build other park structures including architecturally stylistic convenience stations, speaker towers, circulation systems, and landscaped terraces. In addition to the construction of Aquatic Park, WPA artisans under the auspices of the Federal Art Project worked on the Bathhouse, crafting tile mosaics, colorful painted murals, sculptures, lighting fixtures, and terrazzo floors.

The Fourth Army Anti-Aircraft command and the San Francisco Port of Embarkation (Fort Mason) began using Aquatic Park in 1941, and public access was restricted. During the war, the Army built a small wharf on the west side of the cove. The Army used the site through World War II before relinquishing control back to the City of San Francisco in 1948.

After the Army vacated Aquatic Park, the park remained closed due to a lack of city operating funds. Sometime during this period, the city removed a water pumping station from the southwest corner of the park, and the vacant area became a bocce ball court.

In 1951, the opening of the San Francisco Maritime Museum in the Bathhouse building at Aquatic Park provided a compatible and viable use for the structure, and the museum became the anchor for the park's redevelopment. In 1957, the State of California restored the Hyde Street Pier for the display of historic vessels on the east side of Aquatic Park and opened it to the public in 1963.

In 1956, the cable car turntable for the Powell-Hyde line was constructed on the corner of Lot 9, east of Aquatic Park. Planning for a park was



soon underway and in 1962, Victorian Park was constructed. In 1982, the realignment of the cable car line lead to redevelopment of Victorian Park to accommodate these changes. Most of this design remains today.

In 1972, the United States Congress established the Golden Gate National Recreation Area (GOGA) and granted the National Park Service (NPS) authority to acquire by donation nearby resources related to maritime history. Between 1977 and 1978, ownership of the historic vessels, Haslett Warehouse, Victorian Park, and Aquatic Park was transferred from various owners to the NPS. In 1983, the Golden Gate National Recreation Area consolidated the maritime resources and on June 27, 1988, Congress passed public law 100-348. This established the San Francisco Maritime National Historical Park as a separate administrative unit of the NPS, including the maritime museum, historic vessels, park areas, and associated historic structures.

Today Aquatic Park is a historic designed landscape, significant in the area of community planning and development by the Works Progress Administration and the Federal Art Project during the 1930s. Additionally, Aquatic Park is an outstanding example of the Streamlined Moderne style applied to the design of both the buildings and grounds that make up the park. Today, the park remains a unique recreational and cultural resource along the San Francisco waterfront. (Figure 1)



**Figure 1.** View from the west end of the park, looking toward the West Speaker Tower, Bathhouse, and bleachers. (NPS, 2007)

## Scope and Methodology

The designed landscape of Aquatic Park was documented in 2001 as part of the National Park Service Cultural Landscapes Inventory (CLI).<sup>2</sup> Revised in 2004, the CLI identifies 21 individual structures and landscape features that contribute to the significance of the historic district. While the CLI documents and evaluates the historical significance and condition of the landscape, it does not provide treatment recommendations for preservation or management of contributing landscape resources. Treatment of the historic designed landscape is the focus of the Cultural Landscape Report (CLR) for Aquatic Park.

The CLR for Aquatic Park has two parts. *Part 1* incorporates and supplements portions of the Aquatic Park CLI and includes a site history, existing conditions information, and a summary analysis and evaluation of contributing resources. *Part 2* of the CLR provides treatment recommendations for preservation, rehabilitation, and potential restoration of key features based on documentation, park management objectives, contemporary park operations, and historical significance.

Several existing technical reports and research materials provided information about the history and physical development of the cultural landscape. Key among these was the *Historic Resource Study*; the National Register of Historic Places nomination for Aquatic Park; and the Aquatic Park Cultural Landscapes Inventory.

Research also included reconnaissance and review of materials in several regional archives and collections. Most important among these were the collections at San Francisco Maritime National Historical Park. The park has a large repository of historic photographs, maps, site plans, and design drawings. Collections at the San Francisco Public Library include a summary report on the Works Progress Administration projects in San Francisco and an extensive collection of historic photographs. Pertinent information about the character of the landscape during and after the period of significance was derived from aerial photographs located in the Pacific Aerial Survey archives (1938-2005), and the Earth Sciences Library Map Room at the University of California, Berkeley.<sup>3</sup>

Fieldwork and site visits to document existing conditions occurred in February, March, and April 2007. Additional work was done in 2008

and 2009 as the rehabilitation work on the bleachers began. Site work consisted of verification of information from the 2004 CLI, interviews with park maintenance and resource staff, and condition assessments for landscape features.

Upon completion of the CLR Part 1, a treatment workshop with park staff helped identify the management and maintenance issues to address in *Part 2* of the report (see Appendix A). All recommendations in the CLR are based on evaluation of landscape resources that contribute to the district and support the direction provided in current park planning and management documents. All treatments documented in the CLR follow guidance provided in *The Secretary of the Interior Standards for Preservation, with Guidelines for the Treatment of Cultural Landscapes*. The focus for treatment recommendations in the CLR is the historic designed landscape of Aquatic Park, or the Core Area as defined in this report. While the Bocce Ball courts and Victorian Park are within the study boundary and are part of the managed grounds of Aquatic Park, they do not contribute to the historical significance of the park. Therefore in this report, treatment recommendations for these areas are limited and address rehabilitation to promote more sustainable maintenance practices and overall design compatibility with the historic character of Aquatic Park.<sup>4</sup>

## Study Boundary

The study boundary for the Cultural Landscape Report encompasses the current NHL district boundary with a few variations. (Figure 2) On the west side of the park, the study boundary begins at the intersection of Beach Street and Van Ness Avenue, and extends west to the retaining wall marking the boundary between San Francisco Maritime National Historical Park and Fort Mason, Golden Gate National Recreation Area. From there the study boundary continues north from the end of Van Ness Avenue along the Municipal Pier before cutting back across the cove to a point near the East Convenience Station, continuing around the east side of Victorian Park, and back up to Beach Street before heading west back to Van Ness Avenue and the beginning point.



Figure 2. Study Boundary

Cultural Landscape Report: Aquatic Park

San Francisco Maritime  
National Historical Park  
2010



## Endnotes

### Introduction

1 National Park Service. Draft, General Management Plan, Environmental Impact Statement, San Francisco Maritime National Historical Park, California, (National Park Service, 1996), 17-18.

2 The boundary for the cultural landscape documented in the CLI is a modified version of the current NHL boundary and does not include Victorian Park, nor the small strip of land on the west side of Van Ness Avenue, sometimes referred to as the pocket park. The Cultural Landscape Report for Aquatic Park includes both areas.

3 These archives and institutions contacted during research did not provide new information for this report: the California Department of Parks and Recreation, California State Archives, the San Francisco Department of Public Works, and the San Francisco City Parks and Recreation Department.

4 When work on the Cultural Landscape Report began, the historical significance of Victorian Park was undetermined. A draft determination of eligibility (DOE) for the park was prepared in July 2007, and based on this evaluation, Victorian Park did not meet the eligibility criteria for listing in the National Register of Historic Places.



# SITE HISTORY

## Pre-Contact Landscape

Before the Europeans discovered San Francisco Bay, the land south of the Golden Gate, from the San Francisco peninsula to East Bay and south to Monterey, was part of the aboriginal lands of the *Ohlones* (also called *Costanoans*). At the time of the Spanish occupation of San Francisco in the late 1700s, approximately 1,400 *Ohlone* people lived in the areas around San Francisco and San Mateo, moving between seasonal and permanent village sites. Ethno-histories document the presence of small villages along the San Francisco peninsula, shoreline, and marshlands. In the northern part of the San Francisco, villages were located at today's Crissy Field, Sutro Baths, and Fort Mason. The village at Fort Mason was located on the west side of the cove, near the high promontory overlooking the bay.<sup>1</sup>

## Spanish and Mexican Period

In 1776, Spanish Captain Juan Bautista de Anza led 240 people from Tubac, Mexico, north to San Francisco where they planned to establish a permanent settlement. Following the arrival of Anza, the northern portion of the San Francisco peninsula was set aside for the Presidio de San Francisco. San Francisco Bay was a strategic harbor for the Spanish, and in 1793, the Castillo de San Joaquin was built on the bluff to guard entry to the bay. A second battery, known as Bateria de Yerba Buena, was built approximately two and a half miles east of the Castillo on a point of land that provided an excellent vantage point of the entry to the bay. Known by the Spanish as Punta Medanos, this point of land was called Black Point by the Americans.<sup>2</sup>

The physical character of the cove and the landscape surrounding Black Point changed little during the Spanish and Mexican periods. The landscape, formed in part by the wind and the deposition of sand along the north-south ridge lines, consisted of sand dunes and extensive wetlands around the shoreline. A relatively small battery located on Black Point was the only structure sited near the cove. Between 1794 and 1820,

the battery and Castillo were used only intermittently, and both were abandoned after Spain relinquished rule over California to Mexico.

## 19<sup>th</sup>-Century Site Development

### Early Military and Industrial Use

In 1846, the United States took control of California from Mexico and by March 1847, troops of the United States Army were at the Presidio. The United States recognized the importance of San Francisco Bay for maintaining control of California and military engineers recognized the strategic importance of Punta Menados. Black Point Cove was recommended for inclusion in a military post as early as 1848, and in 1850, President Millard Fillmore established a large military reservation stretching from Black Point westward to the Presidio. In 1851, the boundaries were modified to create a separate reservation, the Point San Jose Military Reservation that encompassed “an arc of eight hundred yards from its northern extremity, from shore to shore.”<sup>3</sup>

Despite the designation of Black Point and Black Point Cove as part of the military reservation, troops were not located at the site until 1863. Without an active military presence to deter development, construction of private homes took place in this area as early as the 1850s. Businesses and commercial enterprises soon followed. In 1869, when the military finally decided to evict the “squatting” industries, substantial opposition mounted, and on July 1, 1870, Congress reduced the size of the Point San Jose Military Reservation, excluding the cove and placing that land in the hands of the private speculators who occupied it at the time.<sup>4</sup> (Figure 3)

By the late 1850s, business owners along the shore began adding fill material to the cove in order to expand the buildable surface area and stabilize the shoreline. Coast survey charts indicate that by 1859, structures were already built over the previous high tide mark and by 1869, bulkheads and wharves were pushing out into the cove almost 20 feet beyond the original shoreline south of Beach Street.<sup>5</sup> New businesses such as the Pioneer Woolen Mills and San Francisco Water Company initially constructed on the south side of the cove, expanded operations north into the cove. (Figure 4)

**Figure 3.** Detail of 1869 coastal survey showing the U.S. military reserve including Black Point, with commercial development on the east side of the point. (Courtesy of the David Rumsey Map Collection, <http://creativecommons.org>)

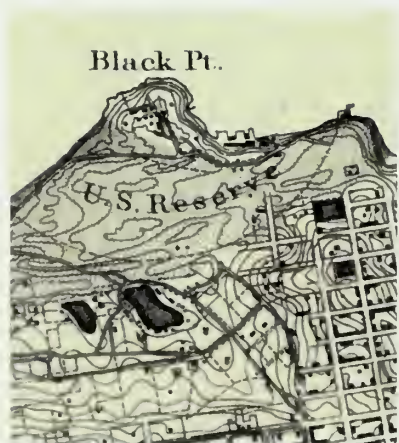

Other topographic changes such as the leveling of the bluff (Sand Point) at the foot of Hyde Street and dumping the material into the bay created another building site, first for the Selby Smelter, followed by the San Francisco Gas Works, on the same footprint. By 1900, approximately half of the block north of Beach Street between the alignments for Larkin Street and Van Ness Avenue had been filled, and in the southwest corner of the cove the Spring Valley Water Works (formerly the San Francisco Water Company) and Dolphin Swimming and Boating Club wharves extended out to the (underwater) alignment of Jefferson Street.<sup>6</sup> (Figure 5)

The General's Pier was the first wharf constructed in Black Point Cove. It was a small structure with a boathouse on the end. On the east side of Black Point, a road connected the Commanding General's quarters to the wharf, where guests to the post often arrived.<sup>7</sup> The second military wharf built in Black Point Cove was at the northwest edge of the cove, at the tip of Black Point. This wharf, known as the Quartermaster's Wharf, was built circa 1871.<sup>8</sup>

### Recreational Land Use

The public began using Black Point Cove for recreation soon after the first homes and businesses were established. Despite commercial use and the prevalent industrial character of the area, by the 1860s the sheltered cove with its sandy beaches and proximity to the city was a favorite spot



**Figure 4** Early view of Black Point Cove. View looking southeast, 1864. (Courtesy of the San Francisco History Center, San Francisco Public Library, M.B. Collection AAB 6715)



**Figure 5** View of the Pioneer Woolen Mills and other industries as development extended north into the cove below Black Point. View from the hill, looking southeast, 1868. (Courtesy of the San Francisco History Center, San Francisco Public Library AAC 7308)

for swimming and recreation. Entrepreneurs soon established bathing concessions near the beach to meet the needs of the public. Around the same time, various rowing and swimming clubs began to use the cove, reinforcing recreational use of the area. In some cases these organizations became centers for various social events such as picnics, barbecues, dances, and banquets. By 1909, three “clubs” were located at the cove, including the South End Boat Club (later called the South End Rowing Club), formed in 1873, the Ariel Rowing Club (later called the San Francisco Rowing Club), formed in 1877, and the Dolphin Swimming and Boating Club. (The Dolphin Club moved to the southwest corner of the cove in 1895.)<sup>9</sup> Van Ness Avenue was paved down to Bay Street by 1900, and some were pressuring the San Francisco Board of Supervisors to grade the bluff and extend the street to the edge of the water. Although used by many, all three clubhouses stood in the way of new development along the waterfront.<sup>10</sup>

## Park Design and Development

### Early Planning for Aquatic Park

As early as 1866, after considering ideas for development at Black Point Cove, pioneer landscape architect Frederick Law Olmsted proposed that the area be developed as a waterfront park. In a report to the mayor and the San Francisco Board of Supervisors, Olmsted expressed his belief that as the “portal of the republic on the Pacific” the City of San Francisco required a proper landing spot where “foreign dignitaries and our own national representatives will land and embark.” Olmsted noted that:

*...there seems to be a suitable place on the east side of the ridge of Point San Jose [Black Point], between the fort and the Pioneer Woolen Mills. It enjoys considerable protection from the sea wind, as is shown by the growth of shrubs, and there is a good depth of water immediately off shore, with good anchorage.*<sup>11</sup>

Olmsted’s proposal was never realized and both industrial use and recreational activities around Black Point Cove managed to coexist through the 1890s. However, by the early 20th century more and more of the city shoreline was being filled and developed.



In 1905, Chicago architect and city planner Daniel Burnham developed a plan for San Francisco, proposing a park at Black Point Cove. Rather than a grand entry to the city as Olmsted proposed, Burnham's plan for the area around Black Point called for a "bay shore park" to protect the character and recreational use of the cove. Burnham's plan depicted a park extending east and west along the shoreline, with the cove itself providing a harbor for boats. The intent of Burnham's plan was "to preserve the beauty of the point (Black Point) and to restrain the encroachment of any buildings other than clubhouses and those of a semi-public character."<sup>12</sup>

Burnham's ideas for protecting the waterfront for its scenic and recreational values were at direct odds with pressure from commercial interests to fill and extend land along the waterfront. This opposition, combined with a lack of funding to undertake Burnham's plan and the city's preoccupation with the aftermath of the 1906 earthquake and fire, probably contributed to the lack of action on Burnham's plan for the cove. Instead, Black Point Cove eventually became a dumping ground for tons of debris and rubble from the Palace Hotel and other downtown buildings following the 1906 San Francisco earthquake and fire. According to one account, 15,000 truckloads of red brick rubble from the hotel "utterly ruined the fine bathing beach" of the cove.<sup>13</sup>

This dumping, along with proposals for additional fill and new construction projects led to the formation of the Aquatic Park Improvement Organization. Formed in 1909, the primary purpose of the organization was to promote establishment of an aquatic park. In April 1909, the group lobbied the San Francisco Board of Supervisors and presented a cost estimate for development of a park. A city bond measure to purchase lands at the north end of Van Ness Avenue for a "public aquatic park" was submitted by the group, but the bond failed to pass in the November election. Just three years later however, the Board of Supervisors backed the idea of a park at the foot of Van Ness Avenue and again, recommended a bond to purchase land. This bond also failed to receive the necessary two-thirds of the vote for approval.

The following year, the army started dumping debris and fill along the western side of the cove in order to construct a seawall and extend McDowell Avenue around the west side of Black Point. Sensing



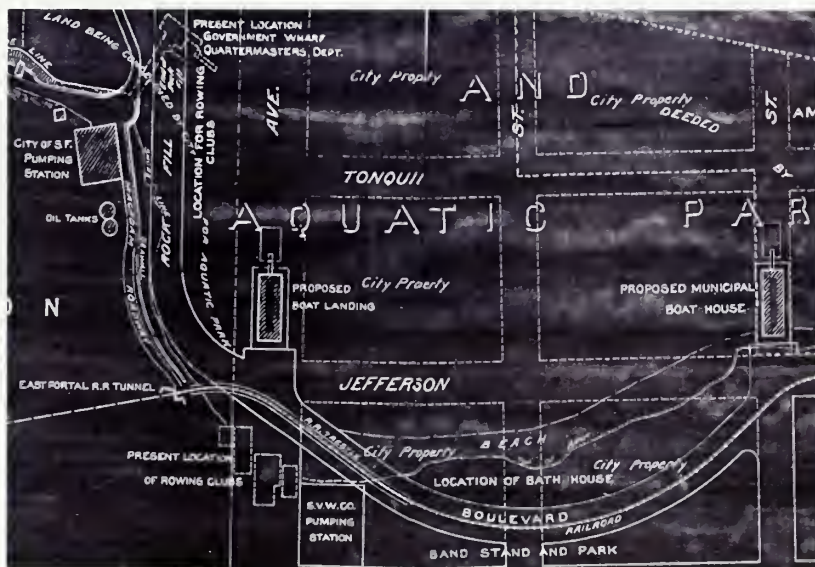

**Figure 6** The State Belt Railroad trestle across Black Point Cove, ca. 1915. Future site of Aquatic Park in on the right. View looking east. (Courtesy of the San Francisco History Center, San Francisco Public Library AAA 6723)

that the opportunity to establish a park was slipping away, the San Francisco Recreation League petitioned the San Francisco Board of Supervisors to obtain an order to stop the dumping. In addition, the Recreation League and the South End Rowing Club—who by then had a boathouse at the foot of Van Ness Avenue, tried to arrange an exchange between the Southern Pacific Railroad with a parcel at the foot of Van Ness Avenue and land owned by the City of San Francisco on the southern waterfront. By March 1914, after the State Belt Railroad completed construction of a trestle across the cove and a tunnel under Black Point, several other rowing clubs joined the San Francisco Recreation League to protest additional filling of the cove at the north end of blocks 33, 36, and 37 (located on either side of today’s Jefferson Street). Filling operations in the cove ended in 1914, although the city continued dumping into the following year. The damage to the cove was tremendous; the sand beach was gone, covered with tons of rubble, mud, and rock, and much of the former cove was now dry land. Moreover, the railroad trestle interrupted access to the water for swimmers and rowers. Community concern eventually reached a critical point when public support galvanized and key officials for both the army and city became involved and supported the movement to construct a public park.<sup>14</sup> (Figure 6)

Over the next three years the Recreation League and the others maintained their advocacy for a public park at the cove. They made presentations to the San Francisco City Board of Supervisors, fought to overcome opposition from commercial developers, and continued to work on a land exchange. Finally in May 1917, the Southern Pacific Railroad paid the city \$392,000 as compensation for the greater value of the Market Street lots it received in exchange for the property at the foot of Van Ness Avenue. These funds were used to further the development of the aquatic park.<sup>15</sup> The Southern Pacific land was only a portion of the waterfront land that the city planned to incorporate into the park. In December 1917, the San Francisco Board of Supervisors voted to condemn part of Block 37 located on the south side of Jefferson Street (including the shoreline where the rowing club boathouses and pier for the Spring Valley Water Company were located). The following spring, the submerged lots in Blocks 406, 427, 428, and 430 (in Black Point Cove) were condemned. Acquisition of lands continued into 1924, while the city was developing new plans for the park.<sup>16</sup>

In November 1918, the San Francisco City Board of Supervisors authorized the Board of Public Works to contract for the development of plans and specifications for the Aquatic Park (as it was being called). In 1920, the city announced a design competition to prepare architectural renderings for Aquatic Park based on the surveys and site plan that John M. Punnett was to prepare for the Bureau of Engineers.<sup>17</sup> (Figure 7)



**Figure 7.** John Punnett's 1922 site plan for Aquatic Park. Although the plan was revised several times over the years, the basic layout and design for the park depicted in this drawing remained the blueprint for future design. (PWR, TIC file GOGA 41956)

The winning entry to the competition was a submittal by the architectural firm of Bakewell, Brown & Baur. (Figure 8) Their proposal retained many elements of John Punnett's plan for the park and also called for the construction of several new structures, boat landings, the development of a bathing beach, formal public avenues and vehicular approaches to the park, landscape plantings, an "amusement pier" along the east boundary, and a matching pier on the west to create a yacht harbor and space for three rowing clubs. The plan also featured a broad esplanade with a central bathhouse framing the shoreline, which, along with the two piers, created a formal symmetry to the overall site plan. In December 1922, the San Francisco City Park Commissioners approved an agreement with the firm and appointed them to prepare a prospectus and plan for the park.<sup>18</sup>

In the meantime, limited development of the park began. In 1920, the city contracted to grade the land between Larkin Street and Van Ness Avenue. In 1921, work began to move the State Belt Railroad trestle that

**Figure 8.** Detail of the winning entry in the Aquatic Park design competition, submitted by Bakewell, Brown & Bauer. (Courtesy of the San Francisco History Center, San Francisco Public Library AAA 6903)



cut across the cove and relocate the tracks along the shoreline. After the trestle was removed and the land graded, the San Francisco City Board of Supervisors transferred jurisdiction of the park to the San Francisco Park Commission.<sup>19</sup> At the same time, engineer Frank White was hired to prepare plans and specifications for the construction of the “new government wharf, the breakwater, and the recreation pier that would transform the cove into a sheltered harbor.”<sup>20</sup>

To implement the plan developed by Bakewell, Brown & Baur, the city began to push for acquisition of more land, focusing on lands along the eastern edge of the Fort Mason Military Reservation and the submerged lands of the cove. The legal proceedings for these acquisitions dragged on and delayed construction in the park for several years. Finally in 1924, the California State Legislature approved the transfer of the submerged lands to the city. Approval from the War Department, which was necessary because of the planned removal of the Quartermaster’s Pier and the use of some of the military lands on the east edge of the reservation, represented the only remaining obstacle to construction.

Impatient with delays in Washington, the city authorized the expenditure of funds to extend Van Ness Avenue to the northeast tip of Black Point and in 1931, the city hired 22 men to manually clean,



grade, and prepare the shoreline area below Beach Street. After receiving approval for the government to build on the site, the army contracted to remove and rebuild the wharf at the city's expense. The former seawall and small walkway around the east side of Black Point were slowly filled in by thousands of cubic yards of fill, placed to form a broad platform for an extension of Van Ness Avenue out towards the pier. In addition, 47 truckloads and 12 railroad cars full of cobblestones salvaged from reconstructed San Francisco streets were hauled to the site and stockpiled in the park.<sup>21</sup> A crude seawall was constructed around the shoreline to hold the unconsolidated fill material. (Figure 9)

At the same time the grading and filling was in full swing, casting for concrete pilings of the pier were underway. In July 1931, the city contracted to build approximately 636 feet or about one-third of the eventual length of the new pier. Construction of the support pilings began in August of 1931, and by the middle of 1933 the pier extended its full 1,850-foot length. (Figure 10) Concrete curbing, benches, and parapet wall along the pier were added in October 1933. Work on the pier ended in March of 1934.<sup>22</sup> Construction of Municipal Pier and preparatory hand grading for the proposed park proceeded with small amounts of money from the city. Work was completed with borrowed tools and salvaged materials, such as the lumber used for cribbing and the tons of granite cobblestones hauled to the site. It was soon clear



**Figure 9** Large amounts of debris and rubble dumped along the shoreline of the cove were used to construct a crude seawall. (*San Francisco Maritime NHP, Historic Documents, Photograph Collection, P88-035.00033*)



**Figure 10** Municipal Pier under construction in 1932. Note the realigned State Belt Railroad trestle in the foreground. (*Courtesy of the San Francisco History Center, San Francisco Public Library, AAC 2288*)

however, that proposals for park development specified in both John Punnett's site plan and the 1922 Bakewell, Brown & Bauer plan, were prohibitively expensive. The city could not assume construction costs on its own and for the next two years, construction at the park limped along with the aid of State Emergency Relief Administration (SERA) labor, and with private donations of equipment.<sup>23</sup>

In the summer of 1935, the Assistant Engineer for the City of San Francisco, Clyde Healy, and other municipal officials flew to Washington, D.C. seeking federal funding for several city-sponsored park projects, including development at Aquatic Park. The city submitted an application for \$1,777,887 to the newly formed Works Progress Administration (WPA). The project at Aquatic Park was described as requiring:

*The construction of 3,250 cu. yds. masonry rubble sea wall, 1 bath house, 2 boat houses, 2 life saving stations; paving 101,000 sq. ft. of promenades; excavation and fill of 20,000 cu. yds.; relocation of 1,400 linear feet of railroad track; the installation of flood light system for night swimming and rowing, and approach wharf to school boat house, pile cutter berths, and landing floats.*<sup>24</sup>

The availability of funding through the federal WPA program eventually provided the means to construct Aquatic Park. The project was approved and the San Francisco City Board of Supervisors appropriated an additional \$6,000 for engineering plans, specifications, and project supervision not provided under the WPA grant. The board appointed John Punnett as the consulting engineer for the project. On January 16, 1936, Punnett presented a revised plan (his third plan for the park) to the San Francisco City Board of Park Commissioners for approval.<sup>25</sup> Punnett's revised site plan for the park introduced asymmetry and contemporary forms for the layout of the circulation system, open spaces, and planting beds. These forms were designed to complement the new Streamlined Moderne architectural style of the park buildings and structures designed by architect William Mooser Jr. With plans and specifications underway, construction could begin.



## Works Progress Administration

In early 1936, 782 WPA laborers arrived at the site to begin construction of Aquatic Park.<sup>26</sup> One of the initial projects for the crews was construction of a new concrete and stone seawall along the shore of the cove. The new seawall was designed to follow a gentle curve around the cove, and also to create a structurally stable area south of the excavations for construction of the new Bathhouse at the foot of Polk Street. Masons laid thousands of basalt blocks, hauled to the site between 1931 and 1933. These materials were collected from city streets that were being modernized and widened to accommodate better vehicle access to the new Golden Gate and Bay bridges. Other fill came from the excavation for the Bathhouse and rubble collected on the beach. (Figure 11) Work on the wall progressed gradually, rising and curving along the shoreline until it reached the base of Municipal Pier. The former rubble and concrete seawall haphazardly constructed near Municipal Pier in 1931 was torn down, and the base of the structure reused as the foundation for the new wall. Debris, along with the rubble from the beach and other site grading was used to backfill the seawall. (Figure 12)



**Figure 11** Collected from city improvement projects, a variety of salvage materials were brought to the site and used as fill material. View looking west. (*San Francisco Maritime NHP, Historic Documents, Photograph Collection, P88-035.00027*)



**Figure 12.** Detail of WPA photograph showing work crews using derricks, pulleys, and other devices to place large stone for the foundations of structures built around the cove. Note the building debris dumped on the slope for use as fill. View looking west (*San Francisco Maritime NHP, Historic Documents, Photograph Collection, P88-035.00007*)



**Figure 13.** WPA photograph showing the extension of Van Ness Avenue down to the Municipal Pier, July, 1936. (*San Francisco Maritime NHP, Historic Documents, Photograph Collection, P88-035.00048*)

Once the seawall was completed, additional excavations including cuts, fill, and overall grading for the park began. Fill was added along the west side of the park to allow for the extension of Van Ness Avenue to the Municipal Pier. Headstones from city cemeteries (closed throughout the city in the late 1920s) were cut and shaped to make a flat plug between the original 1911 military seawall and the new WPA seawall, closing a gap between the two structures. Van Ness Avenue was graded and paved all the way to the pier providing access for construction trucks and other vehicles. (Figure 13)

### Building and Landscape Design

In June, 1936, shortly after the WPA project to construct Aquatic Park began, City Architect William Mooser Jr. was selected to develop designs and draft plans for the buildings in the new park. Mooser was instrumental in initiating the request for funding park construction through the WPA, and he certainly had more than the typical bureaucratic interest in the project after he was appointed branch manager for WPA operations in San Francisco.<sup>27</sup> The central building in Aquatic Park—the Bathhouse—was designed by Mooser in collaboration with civil engineer Elmore Hutchinson.<sup>28</sup> The design for the building was conceived prior to the start of the WPA project. Mooser and Hutchinson both expressed a personal commitment to a building design and architectural character that would be a lasting monument in the park.

All of the structures in Aquatic Park were designed in the Streamlined Moderne style, which some consider a variant of the International style. The architectural characteristics of the style are predicated on:

*...a commitment to the processes and aesthetics of the machine age... It was marked by a combination of flat and curved walls, light in tone and often topped with silvery handrails of tubular metal that enclosed terraces. Extensive use was made of glass blocks especially in the curved walls and around entranceways. Occasionally circular windows balanced rectangular elements.<sup>29</sup>*

Although not strictly aerodynamic, the curved roof lines and rounded corners of buildings designed in this style echoed the visual characteristic

of airplanes and ships constructed using aerodynamic engineering principles. Nautical references to luxury liners found their way into the design components of many buildings during the 1930s, including those of Aquatic Park. (Figure 14) Press releases from the WPA played on both the nautical and modern aspects of Mooser’s design and described the Bathhouse as:

*...streamlined and modern to the last degree . . . with rounded ends, set-back upper stories, porthole windows and ship rails, its resemblance to a luxurious ocean liner is indeed startling.*<sup>30</sup> (Figure 15)

The marine themes were repeated in the Bathhouse murals and tile work, and characteristics of the Streamlined Moderne style were carried into the landscape through the curvilinear lines of circulation systems, retaining walls, and the Municipal Pier.

Following his appointment as the supervisor of operations for the WPA in San Francisco, William Mooser Jr. hired his father, William Mooser Sr. as a consulting architect to oversee construction of the Bathhouse and other buildings. The father-and-son team of architects practiced together as the William Mooser Company and had undertaken a similar working arrangement in the late 1920s during the design and construction of the Santa Barbara Courthouse (only with the son as the on-site supervising architect). With William Mooser Sr., the younger architect had someone on whom he could rely and someone he trusted to get it right. Perhaps because of this arrangement, construction drawings for many of the buildings at Aquatic Park were often generated as buildings were under construction.



**Figure 14** Architectural details such as wavy lines, metal railings, and nautical-style windows are characteristic of the Streamlined Moderne style expressed in the structures and grounds at Aquatic Park. (NPS, 2008)

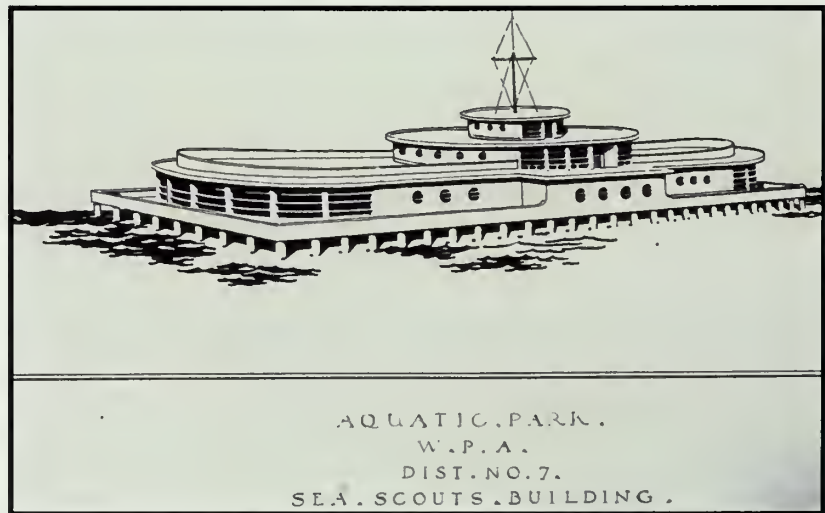

**Figure 15** The Aquatic Park Bathhouse designed by William Mooser Jr. displayed many architectural components of the Streamlined Moderne style. (Courtesy of the San Francisco History Center, San Francisco Public Library, AAA 6748)



When drawings were made, the WPA draftsmen under the supervision of William Mooser Sr. drew them.<sup>31</sup>

In addition to the Bathhouse, William Mooser Jr. designed three stylistically compatible convenience and lifesaving stations (also known as the roundhouses). One convenience station was sited at the west end of the park near the junction of Municipal Pier and Van Ness Avenue. The second convenience station was located at the east end of the park at the terminus of Jefferson Street, and a third convenience station was located at the end of Municipal Pier. Two speaker towers designed to anchor each side of the park were located just south of the East Bleachers and west of the West Bleachers. Plans were also developed for a boathouse for the Sea Scouts and a new boathouse and clubhouse for existing rowing clubs slated for removal. Mooser's emphasis on a consistent modern design style is evident in all of the structures and detailing as well as the areas around the buildings which he designed to provide a setting for modern sculptures created by artists in the Federal Art Program of the WPA. (Figure 16)



**Figure 16** William Mooser Jr.'s concept for the Sea Scouts building with rounded rooflines and strong nautical references, was to be part of the WPA work but because of budget constraints, the structure was never built. (*San Francisco Maritime NHP, Historic Documents*)

General site planning and landscape design for the new park was largely based on John Punnett's 1936 Landscape Plan. In many ways Punnett's plan represented a modern interpretation of the 1922 Bakewell, Brown & Bauer park design which used classical forms and a Mediterranean Revival style. Although several elements from the 1922 design were incorporated, Punnett's revised plan adopted a more contemporary style, compatible



with the architectural character of the new buildings designed by William Mooser Jr. . The site plan focused development around the cove and included a broad sandy beach extending all the way around the cove to the base of the Municipal Pier. On the east side of the park, Larkin Street was extended separating Aquatic Park from Block 9. A broad promenade followed the curve of the beach and shoreline, extending to the arcing structure of the Municipal Pier, which enclosed the cove. Curvilinear walkways connected the primary structures with the beach and cove, creating a flowing circulation system through the park. (Figure 17)

Based on this framework for design of the park, the San Francisco City Office of Park Commissioners developed a “Landscape Plan” for Aquatic Park in 1937 under the supervision of Assistant Superintendent T. M. Grabow. These drawings illustrated large areas of open lawn, curvilinear planting beds with plants massed together, foundation plantings, and an allée of trees along the Van Ness Avenue extension creating the character of a strolling promenade out to the pier.<sup>32</sup> Based on subsequent development, it appears for the most part, this planting concept for the park was ultimately used as the basis for planting.



**Figure 17** In the 1936 site plan for Aquatic Park, John Punnett introduced an element of asymmetry and an entirely new architectural vocabulary for the structures designed by William Mooser Jr. Pictured is a photograph of a 1939 model based on Punnett’s plan for the park. (Courtesy of the San Francisco History Center, San Francisco Public Library, AAC 2287)

## Construction of Aquatic Park

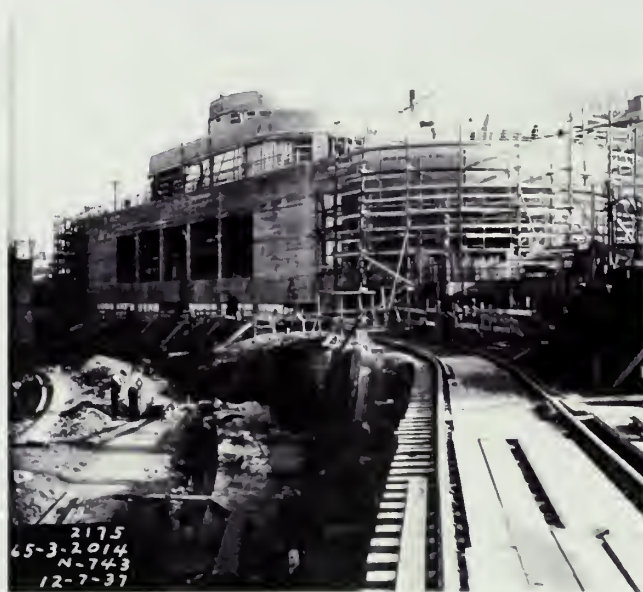

**Figure 18** By February 1937, crews were framing and completing concrete work for the upper floors of the Bathhouse. (*San Francisco Maritime NHP, Historic Documents, Photograph Collection, P88-035.00074*)

WPA work at the park and construction of the park structures was relatively concentrated into a two-year period of year-around activity. In early 1936, excavations for the Bathhouse were underway and before the fall, concrete foundations were poured. The extent of the excavations for the building required relocation of the State Belt Railroad tracks, moved once already, farther south toward Beach Street. By October 1936, framing of the lower portion of the Bathhouse was nearing completion, and work began on the upper stories. (Figures 18, 19) While work was proceeding with the Bathhouse, grading and site work around the structure was also underway. Within the year and by the spring of 1937, framing for the Bathhouse was complete and grading and site work around the skylights and bleachers was nearing completion. (Figure 20) During the winter of 1937, construction was accelerating on the west side of the park, and finish grading of the terraces on the east side of the Bathhouse was completed and prepared for planting. (Figure 21)

By January 1938, most of the external work on the Bathhouse was complete while work on the internal decorations and fixtures dragged on. The graded lawn areas were prepared for planting, and work was underway on the final relocation of the State Belt Railroad between the seawall and the Bathhouse. Concrete was being poured for two large

**Figure 19.** WPA photograph showing the relocated State Belt Railroad tracks, extent of excavations, and by the end of 1937, progress on construction of the Bathhouse. View looking southeast. (*San Francisco Maritime NHP, Historic Documents, Photograph Collection, P88-035.00106*)





**Figure 20.** Site work and rough grading east of the Bathhouse moved quickly through the fall of 1937. View looking west. (*San Francisco Maritime NHP, Historic Documents, Photograph Collection, P88-035.00087*)



**Figure 21.** By December, 1937, finish grading around the skylights provided the level area needed for the establishment of turf grass and planting beds east of the Bathhouse. View looking east. (*San Francisco Maritime NHP, Historic Documents, Photograph Collection, P88-035.00102*)



**Figure 22.** Detail of WPA photograph showing progress towards completion of several structures in Aquatic Park including the West Convenience Station, the West Speaker Tower, the West Bleachers, the final alignment of the State Belt Railroad tracks, and the Seawall around the cove. May, 1938. (*San Francisco Maritime NHP, Historic Documents, Photograph Collection, P88-035.00139*)

speaker towers at each end of the park, and work was nearing completion on two of the three convenience stations. Along the cove, gravel was placed as a foundation for the concrete sidewalks behind the seawall, as well as for a large concrete wall required to retain the slope between Van Ness Avenue and Fort Mason. (Figure 22)

As construction of the structures progressed, the three clubhouses associated with the rowing clubs, which were moved from the foot of Van Ness Avenue to the foot of Polk Street in 1927, were moved yet again, this time east of Larkin Street.<sup>33</sup> (Figure 23)





In April 1938, work began on the concrete bleachers over the men’s dressing rooms on the east wing of the Bathhouse and the women’s dressing rooms on the west wing. The following month, waterproofing on the East Bleachers was underway and the West Bleachers were nearing completion. (Figure 24)



Work on other structures in the park progressed quickly over the next six months to the point where the majority of park structures were complete and ready for use. Although the WPA officially turned the Aquatic Park over to the city and the park was officially opened to the public on January 22, 1939, many elements of the “completed” structures remained unfinished. Unpainted sections of the Bathhouse murals were marked with chalk outlines, half of the tile mosaics were incomplete, and the three convenience stations were only partly finished. Other elements



**Figure 23** In 1938, the remaining rowing clubs located around the cove were moved once more to make room for the construction of the remaining park structures. (*San Francisco Maritime NHP, Historic Documents, Photograph Collection, P88-035.00139*)

**Figure 24** Detail of a WPA photograph showing construction and waterproofing of the East Bleachers. View looking east. (*San Francisco Maritime NHP, Historic Documents, Photograph Collection, P88-035.00140*)

were dropped from the project because there was simply not enough time or money to complete them including the proposed boathouses and buildings for the rowing clubs, the building Mooser designed for the Sea Scouts, and the additional pier designed to enclose the cove on the east side of the Aquatic Park.

A summary and status of the work in Aquatic Park was documented in a memorandum prepared in October 1939 by J.J. Mieldazis. (Figure 25) His memo was part of an investigation into charges of fraud and the use of federal funds to complete the Bathhouse for private use (as a private casino).

The memo documented the following summary:

*Completed work for Aquatic Park:*

- *The seawall*
- *Grading*
- *Pavements*
- *Landscaping*



**Figure 25.** The bathing beach at Aquatic Park in 1939. Although the memo by J.J. Mieldazis suggests that several components of the new Aquatic Park remained unfinished, many key features were complete by the fall of 1939 and available for public use. View of the Beach Promenade and beach area looking east. (Courtesy of the San Francisco History Center, San Francisco Public Library, AAA 6733)

- *The exterior of the Bathhouse unit (including the east and west bleachers)*
- *East and west convenience stations*
- *Two speaker towers*
- *Relocated State Belt railroad tracks*
- *Installation of a flood light system to allow for nighttime swimming and rowing*

*Work not completed as of October 1939:*

- *Interior work in the Bathhouse including the installation of stainless steel window strips, completion of tile mosaic, sculptural work, and some minor finish hardware installation*
- *The convenience station at the end of the Municipal Pier (estimated as being only 30 percent completed)*
- *The granite for Bufano’s sculptures had been purchased and seven of the eleven sculptures were complete; of the remaining four, two were 60 percent complete and two were 40 percent complete<sup>34</sup>*
- *The floodlight system was not complete due a “controversy” between architect William Mooser Jr. and the city<sup>35</sup>*

*Work not constructed and abandoned:*

- *Structure for the rowing clubs on the west side of the cove*
- *Public school rowing and sea scout structure on the east side of the cove*
- *Approach wharf, cutter berths, and landing floats*

Mieldazis also noted that the beach was “inadequate” for recreation and remedial action by the city was required to prevent scouring of the beach by high tides. The memo went on to note that maintenance and repair of the beach was the city’s responsibility.<sup>36</sup> (Figure 26) The beach was initially stabilized using wood breakwaters. Then in July 1941, 80 million cubic feet of sand (excavated during construction of the Union Square Parking Garage) was hauled to Aquatic Park and used to supplement and re-contour the beach. (Figure 27) Only three years later, erosion continued and tidal action began to undermine the sea wall, at which point additional sand was brought in and wood groins were placed in the sand to mitigate future erosion.<sup>37</sup>



**Figure 26** Agitating with hoses to redistribute sand and replenish the beach, 1939. (Courtesy of the San Francisco History Center, San Francisco Public Library, AAA 6708)

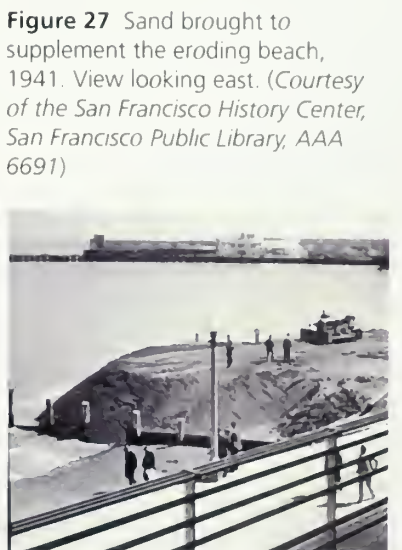

**Figure 27** Sand brought to supplement the eroding beach, 1941. View looking east. (Courtesy of the San Francisco History Center, San Francisco Public Library, AAA 6691)



Although not mentioned in the report, only a few of the plantings originally depicted on John Punnett's landscape plan were installed by the time of the park dedication in 1939. The exception to this appears to be the high profile areas in the park. For example, a few historic photographs show plant materials in the planting beds along Beach Street in front of the Bathhouse. (Figure 28)

**Figure 28.** Plantings installed in front of the Bathhouse for Dedication Day, January 22, 1939. View from Beach Street, looking west. (*San Francisco Maritime NHP, Historic Documents, Photograph Collection, P81-073.1n*)



Following the park dedication, the San Francisco Park and Recreation Department continued planning for the complete development of Aquatic Park, and the city continued looking for revenue to operate the existing facilities. With the Bathhouse under utilized, the city decided to lease the building to private concessionaires, Leo and Kenneth Gordon. The Gordons operated the Bathhouse as a restaurant and bar known as the "Aquatic Park Casino." The private use of building created considerable controversy and after an investigation, the Gordons were evicted. The Bathhouse remained mostly vacant for another year. In 1941, an exhibit of maritime artifacts and ship models previously exhibited at the Golden Gate International Exposition on Treasure Island was placed in the "Blue Room" of the Bathhouse, and the building was again open to the public.

In 1940 a supplementary park plan was prepared for a 204-space parking area east of the Bathhouse along Beach Street between Larkin and



Hyde Streets (in the approximate location of the present-day Victorian Park). These plans, approved by City Parks Commissioner Herbert L. Fleishhaker, indicate the city was planning to plant 37 street trees, approximately 2,200 shrubs, add 26,000 square feet of lawn area using 150 pounds of blue grass and rye seed, as well as 7,000 pieces of ground cover in Aquatic Park.<sup>38</sup> The degree to which this plan was implemented is unknown.

In a 1941 a plan approved by the city's superintendent of parks, John McClaren, addressed the southwest corner of the park. This plan depicted a play area in the space now occupied by the bocce ball courts. A walkway system moved around play spaces including a sandbox, a slide, and a merry-go-round, separated by grassy areas.<sup>39</sup>

In spite of these plans and proposals for additional development, the overall landscape character of the Aquatic Park remained relatively austere. Several factors contributed to this landscape character including the limited amount of city funds going into the park after the WPA project, the limited amount of additional planting undertaken in Aquatic Park by the city, and most importantly, the onset of World War II and use of Aquatic Park by the army. Although these events curtailed full implementation of the 1937 landscape plan, or any subsequent plans, in the end the open landscape character of the grounds in 1941 complemented the Streamlined Moderne architecture of the park buildings, and presented a very integrated overall park design.

## Military Use

In 1941, as part of the military troop mobilization plans for World War II, the troops of Battery B, 216th Coast Artillery Battalion arrived in San Francisco and quartered in Bathhouse. When the military arrived at Aquatic Park, workers were busily removing the last traces of equipment and furnishings left over from the Gordon's casino operation, as well as the various maritime artifacts and ship models from the exhibit in the "Blue Room." As the headquarters for the Fourth Army Anti-Aircraft command, the park landscape was organized into a specialized military post. The military motor pool used the vacant lot east of the park. Sentries were posted throughout the park, the motor pool area was fenced off, and Aquatic Park became "off-limits" to the public.<sup>40</sup>

In February 1942 the army expanded into other areas of the former park and sent a request to the Board of Park Commissioners for use of the Municipal Pier and East Convenience Station. In July both requests were approved. Additionally, the army requested permission to build a small wharf at the west end of the cove near the West Convenience Station and end of the Municipal Pier. Construction of the pier was authorized in December 1943.<sup>41</sup> This same year, a fence (part of the perimeter fences around Fort Mason) was installed along the west side of Van Ness Avenue, and a multi-car garage was constructed in the level area between Van Ness Avenue and the Fort Mason retaining wall. A dispensary and medical aid station were sited near the men's shower.<sup>42</sup>

As the war ended, the military began to make plans to transfer Aquatic Park back to the city. The last soldiers vacated the Bathhouse building in February 1946. Before the property was returned to the city, the army restored the building and repaired the structural damages that had occurred during the seven years of military use. (Figure 29) The landing pier at the west end of the cove was also left behind, probably at the request of the city. The park would have been fully returned to the city had a tug not crashed into the Municipal Pier. Once the required engineering studies were completed, actual repair work on the pier continued through 1947. The pier was returned to the city in early 1948 and the army relinquished its lease on Aquatic Park that same year.<sup>43</sup>



**Figure 29.** View looking toward the west side of the park from the Bathhouse, 1946. (Courtesy of the San Francisco History Center, San Francisco Public Library AAA 6697)

## Multiple Use Public Park

### San Francisco Senior Center

In 1947, a portion of the Aquatic Park Bathhouse became the home the San Francisco Senior Center. Under the auspices of the Senior Center, the lower eastern portion of the building was remodeled to better suit the group. Today, the San Francisco Senior Center, established in 1947, is the oldest, private, non-profit senior center in the United States.

### Bocce Ball Courts

At the time Aquatic Park was developed in the late 1930s, the Black Point Pumping Station remained in the southwest corner of the site, although it was not in use.<sup>44</sup> Adjacent to the new Aquatic Park, this area was designated for park development as early as 1936, when John Punnett designated this area for “Future Park Development.” In 1937, when the city prepared its plan for Aquatic Park, the drawing included proposals for a small rectangular-shaped area southwest of the Bathhouse, enclosed by planting beds with an interior walkway and benches. Access to the area was off Beach Street, with another short walkway connecting to Aquatic Park. Although next to Aquatic Park, the small area appears to have been designed as a largely self-contained park, rather than an extension of Aquatic Park. By 1940, the Black Point Pumping Station was gone and the city developed another landscape plan for this area. In the new plan, the east side of the park was open, creating a stronger link to Aquatic Park.<sup>45</sup> While neither the 1937 plan nor the 1941 plan were implemented, the idea of park development for this area remained.<sup>46</sup>

After demolition of the pumping station, and at least by 1947, the vacant lot was informally used as a gathering area for local bocce ball players.<sup>47</sup> Historic photographs from the early 1950s show several bocce courts on the north end of the vacant lot, defined with wood boards, a wood backstop at the end of the court, and a long wood bench for spectators along one side of each court. On the south end of the lot, courts were simply outlined in the dirt. The area was large enough so that six or seven games could be played at one time. Wood benches were located along the side for spectators.<sup>48</sup> (Figure 30)

**Figure 30.** After the Army left Aquatic Park, the open space between the Bathhouse and Van Ness Avenue was quickly adopted by bocce ball players for their courts. View looking south, ca. 1952. (*San Francisco Maritime NHP, Historic Documents, Karl Kortum Collection*)





**Figure 31** The area between the new Bocce Ball Courts and the Bathhouse used for parking, ca. 1952. View looking east. (*San Francisco Maritime NHP, Historic Documents, Photograph Collection A12.16,417.o7n*)



In the early 1950s, the city traded the south lot (on what would have been the south side of alignment for Beach Street) to the Eastman Kodak Company for a warehouse location, and Kodak constructed a building on the lot. The transfer of parkland to a private interest drew protests from many including the San Francisco Maritime Museum Association, the Aquatic Park Bocce Ball Association, and other local groups. The completion of the Kodak building left a roughly triangular-shaped open area north of Beach Street. Bocce ball enthusiasts continued using the west portion of the site, and cars were parked on the east end.<sup>49</sup> (Figure 31)

In 1958, the city initiated planning for a new area for the bocce ball courts. As part of this effort, in 1960 the Aquatic Park Bocce Ball Association engaged San Francisco Architect George Quesada to prepare design schemes for the area. City funding for implementation of the court area was approved as part of the 1959-60 city park budget. In the plan, the bocce ball area is defined on the west by the retaining wall along Van Ness Avenue and by raised planting beds on the remaining three sides. Benches were located along the edges of the planters, and an overhead structure with concrete pylons sheltered two courts. The plan also showed a wood retaining wall with built-in benches located in the far southwest corner of the site. The overhead structure, courts, wood retaining wall,



and raised planting bed along the north side of the area were all built between 1960 and 1961.<sup>50</sup> In the mid-1970s, Lombardy poplar trees were planted along Beach Street, visually screening adjacent building and essentially defining the edge of the park. By 1994 the roof on the overhead structure was replaced, and a planting bed along the east side of the courts was added.<sup>51</sup>

### San Francisco Maritime Museum

When the army vacated Aquatic Park, the buildings were locked and the promise of Aquatic Park as a public facility was unfulfilled. In the 1948 operating budget for the city, the San Francisco City Park Commission requested only enough funding for Aquatic Park to pay a guard and a small custodial staff. The public used the lower decks of the Bathhouse for sunbathing, although swimming was prohibited due to poor water quality. Finally in 1951, with the opening of the San Francisco Maritime Museum in the Aquatic Park Bathhouse, redevelopment of the area had a focus.<sup>52</sup>

Realization of the San Francisco Maritime Museum came about through a concerted effort on the part of Karl Kortum, who became the museum director, and a group of dedicated supporters and volunteers. Kortum's proposal for a maritime museum in San Francisco was patterned on Mystic Seaport in Connecticut which at the time, was attracting some 50,000 visitors annually. Kortum's ideas appealed to a broad coalition of supporters including members of the Chamber of Commerce, the four city newspapers, and prominent members of the various commercial, cultural, and professional circles in the city all of whom were interested in preserving San Francisco's maritime heritage, promoting tourism, and finding an appropriate use for Aquatic Park. A non-profit organization, the San Francisco Maritime Museum Association formed in 1950 to oversee the development of the museum. Kortum received approval from the San Francisco City Board of Park Commissioners to use Aquatic Park and was granted a lease of the Bathhouse for one dollar a year. A wide range of organizations and individuals donated time, money, and artifacts to the new museum.

In addition to displaying relics from historic ships, Kortum encouraged the San Francisco Maritime Museum Association to support the display of intact, preserved historic vessels in the cove. In 1954, the association



**Figure 32.** Contemporary view of the Hyde Street Pier along the wharf east of Aquatic Park. (NPS, 2009)

acquired and restored the square-rigger *Balclutha*, and in 1955 moored the vessel at Fisherman's Wharf. In a parallel effort, the State of California acquired and restored a small fleet of historic West Coast vessels for display nearby at the restored Hyde Street Pier. Soon, the collection of vessels at the site included the schooner *C. A. Thayer*, the scow schooner *Alma*, the ferryboat *Eureka*, and the steam schooner *Wapama*. The steam tug *Hercules* was added in the late 1970s, and in 1988, the *Balclutha* was moved and moored at the pier. In 1963, the collection of historic vessels at the Hyde Street Pier was opened to the public as the San Francisco Maritime State Historical Monument. By the early 1970s, the San Francisco Maritime Museum, with extensive collections that included a maritime and nautical library, was recognized as one of the largest and best in the world. Aquatic Park and the adjacent Hyde Street Pier worked as the center for maritime historical exhibits and a fleet of historic ships jointly operated by the Museum Association and the California State Department of Parks. (Figure 32)

### Victorian Park

During construction of Aquatic Park, the WPA used the lot east of Larkin Street and bounded by Jefferson, Hyde, and Beach streets as the location for a headquarters and staging area for construction materials. When the army used Aquatic Park beginning in 1942, they fenced the lot for use as a motor pool. After the army left, the lot remained vacant until the early 1940s, when the San Francisco City Park Commission began developing alternatives to develop a park in the vacant block. In all of the schemes prepared by the city, the lot was graded to create an upper and a lower terrace. A parking area was proposed for the upper terrace next to Beach Street, and the lower terrace next to Jefferson Street was set aside for recreation. In this area some of the plans specified courts for bocce ball or tennis courts, and a beach area on the west end of the lot. For many reasons, none of these schemes developed past the planning stages.<sup>53</sup>

In March 1946, a 50-square-foot portion of the northeast corner of the block (at the intersection of Hyde and Jefferson streets) was transferred to the San Francisco City Department of Public Works for construction of a sewage pumping plant. A \$70,000 appropriation was allotted in the city's 1947 budget to construct the pumping plant and alleviate the sewage problem that had been plaguing water quality in the cove for over a decade.<sup>54</sup> (Figure 33)



**Figure 33.** View of Lot 9 and the future Victorian Park east of Aquatic Park, prior to construction of the cable car turnaround. View looking west, 1955 (Courtesy of the San Francisco History Center, San Francisco Public Library, AAA 6742)

In 1955 when the city announced plans to sell the property east of the Bathhouse for apartments, Karl Kortum, Director of the San Francisco Maritime Museum, organized a drive to stop the sale and to reserve the site for park development, including expansion of the Maritime Museum.<sup>55</sup> A group called the Citizens Committee for the Preservation of Aquatic Park quickly formed to support both Kortum and the San Francisco Maritime Association. In the end, the opposition was successful and the mayor, who originally endorsed the sale, withdrew his support. In place of the sale, a park and recreation bond was approved by voters to provide funds for general landscaping associated with a proposed transportation museum to be located on the block.<sup>56</sup>

The cable car turnaround for the Powell-Hyde line was built in the southeast corner of the site in 1956. The line entered the block from Hyde Street. This corner of the lot was graded to create a level terrace and platform for the track and turnaround. The cable car line brought additional tourists to the area and was considered a good fit with the goals for revival of the waterfront envisioned by Karl Kortum and others.

During this period the California State Division of Beaches and Parks considered a number of additional proposals for extension of the San Francisco Maritime State Historical Monument and the possible connection between the state collection of historic vessels at the Hyde Street Pier and the collections of the San Francisco Maritime Association housed in the Aquatic Park Bathhouse. There was also interest during this period in incorporating an exhibit related to transportation history at this site. In a 1956 design proposal, the San Francisco architecture firm of Campbell and Wong designed a triangular-shaped museum building



for the Pacific Coast Chapter of the Railway and Locomotive Historical Society. This modern glass building was to be located in the center of the block with a triangular-shaped courtyard. Working with the firm, San Francisco landscape architect Lawrence Halprin developed a site plan that included parking in the northeast corner and a beach area along the north side where ships could be displayed; the cable car turntable remained at the southeast corner. Neither proposal was implemented.

Between 1958 and 1959, the California State Division of Beaches and Parks drafted development plans for Maritime Plaza (Victorian Park). (Figure 34) Not everyone however, favored the proposed design for the park. Karl Kortum, who was actively planning for the area, believed the new park should include Victorian-era features that would, in his opinion, recall the character of “old San Francisco” and compliment the San Francisco Maritime State Historical Monument. Part of Kortum’s vision was to provide an experience that went beyond the confines of the Maritime Museum (Aquatic Park Bathhouse) or the Hyde Street Pier to inspire the renovation of the surrounding neighborhood. The state plan for a “central plaza” that connected to the cable car turnaround and provided visitors arriving by cable car with their “first impression” of the neighborhood and of the San Francisco Maritime State Historical Monument was what Kortum had in mind. When he saw the design proposed by landscape architect Emmett Blanchfield of the Division of Beaches and Parks, he thought the design was “themeless.” In a letter

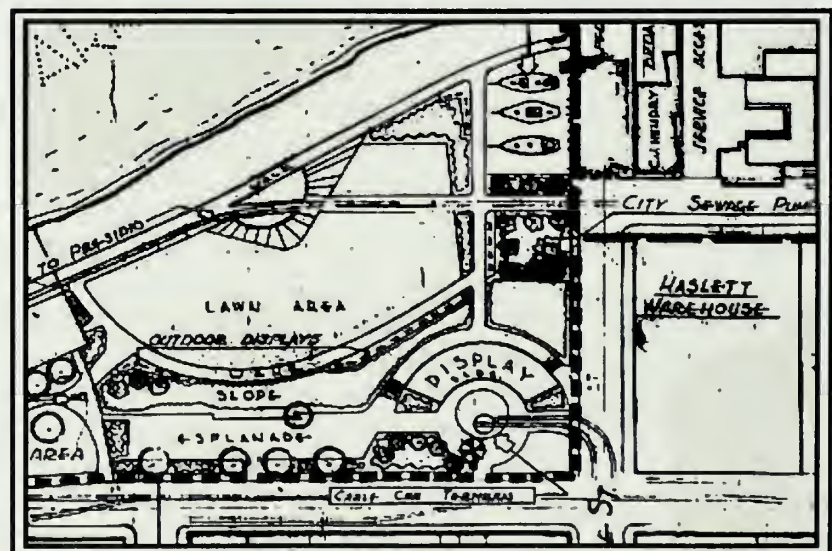

**Figure 34.** Detail of the initial 1958 design for Maritime Plaza (Victorian Park). (San Francisco Maritime NHP, Historic Documents)



written to the division historian, Aubrey Neasham, Kortum complained:

*The impressions that will assail him [the visitor] under the present plans are those of a banal backyard in Marin County . . . of a bourgeois barbeque behind a \$28,000 home in Escondido. It is not old San Francisco. It is last month's Sunset Magazine.*<sup>57</sup>

This was a design that satisfied no one. Blanchfield was also dissatisfied with the design and told Kortum that the directive to design a contemporary park with period character left him “laboring under a piece of composite gobbledygook.” While Kortum supported many components of the design such as the grading, the layout of circulation, and plantings, he believed that Blanchfield’s choice of contemporary materials was a problem. Specifically Kortum objected to the use of redwood slab benches, brick paving, and the use of concrete with redwood header boards in the plaza. Rather, Kortum proposed that basalt blocks were a better choice for the pavements. Not only were “cobblestones” the “essence of old San Francisco,” they could be found at both the waterfront and along the cable car right-of-ways and using them would provide a way to connect “this particular park” to the context of the broader landscape.<sup>58</sup>

After it became apparent that the design of the park was not going to be resolved, the deputy chief of the division advised Kortum to resolve the design himself. Kortum’s solution was to contact San Francisco landscape architect Thomas Church in October 1959. Church provided a plan that Kortum persuaded the state to use. Finally in 1962, staff in the California Department of Public Works, Division of Architecture, incorporating concepts from Thomas Church and others, prepared the plans used to develop the park.

Blanchfield’s 1959 design featured a long, rectangular plaza on the south side of the block that connected the cable car turnaround to the Maritime Museum. In the revised design, the configuration of the central planting bed in the plaza was simplified to a long, rectangular-shaped bed with plantings on each side. A round gazebo was sited on the east end of the plaza and a round planting bed was installed at the west end. The result was a more straightforward circulation pattern along a strong east-west axis. Steps and landings were added on the

**Figure 35.** Revised site plan for the park incorporating some of the ideas of landscape architect Thomas Church, 1962. (*San Francisco Maritime NHP, Historic Documents*)

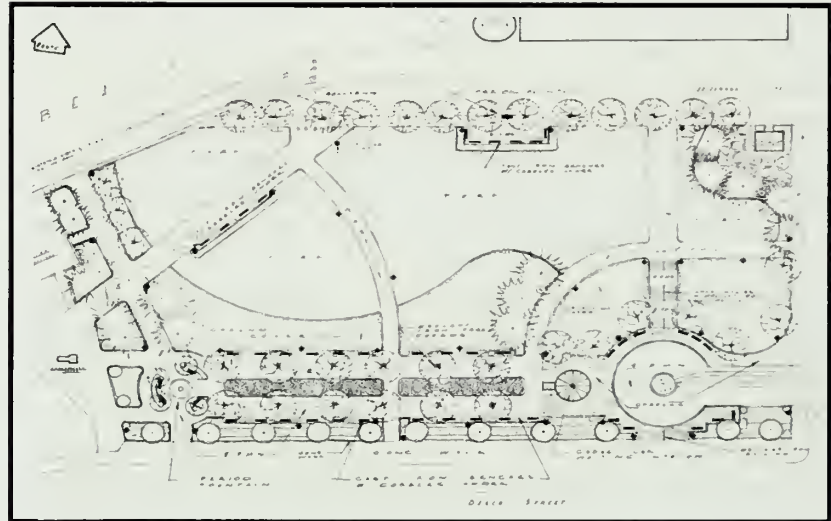

east side of the park and on the north side of the cable car landing, connecting the north side of the park with the water and Hyde Street Pier. Included in the drawing set were details for the cast iron benches, gas-lamp streetlight fixtures, raised planter boxes, metal tree grates and guards, and wrought iron hand railings. The paths and plaza were paved with crushed gravel.<sup>59</sup>

According to Kortum, many of Thomas Church's ideas were incorporated into the final design of Victorian Park. (Figure 35) Some of these include the use of cobblestone paving; the double row of trees in the plaza, and location of the "circular concourse" at the west end of the plaza; the addition of the "grand staircase" in the lower portion of park; and the location and number of ornamental ironworks including the gas lights, benches, tree guards, and fountain.<sup>60</sup> (Figure 36)

**Figure 36** View of Victorian Park and the cable car turn around before the tracks were realigned. (*San Francisco Maritime NHP, Historic Documents, Karl Kortum Collection*)



In 1982, the design for the cable car line into Victorian Park was redesigned. Originally the track entered the park at a 90-degree angle off Hyde Street. With the new design, the tracks entered the park at the southeast corner at roughly a 45-degree angle. Associated with this redevelopment, other modifications to Victorian Park were made, including removal of the steps and landings between the cable car and the lower level of the park; the relocation of the paths; the extension and repaving of the plaza; and construction of a low, concrete retaining wall along the north side of the new turnaround area; and new plantings.

Since 1982 there have been several other changes in Victorian Park. Most of these are the result of operational needs to reduce the high maintenance required to sustain the plantings. Some of the changes include replacement of juniper plants in the area north of the plaza with perennials. Assorted perennials were also planted in the central plaza. Overgrown *Pittosporum* trees planted on either side of the center bed in the plaza were removed and replaced with lower maintenance *Cordylines* in the late 1990s, and *Agapanthus* was planted in the raised bed along Beach Street. The *Maytenus boaria* trees originally planted in this area were also removed and replaced with cherry trees.<sup>61</sup>

## National Park Service

Over several years under city management, the grounds of Aquatic Park fell into significant disrepair. Trash pickups were infrequent, transients slept in the park, criminal activity increased, and between 1960 and 1970 a swimming ban remained in effect. Over time, deferred building maintenance created a number of structural issues and problems, especially at the Bathhouse. The roof was in poor condition and the skylights, originally intended to provide natural light for the dressing rooms, were cracked and leaking, causing failed plaster in the area below the bleachers, including an area under the east and central portion of the bleachers that the Maritime Museum was using as a collection storage facility.

In the lobby of the Bathhouse, moisture from leaking windows also led to significant damage to the painted murals. During this time, the majority of the main floor of the Bathhouse and a portion of the both the west and east Bleacher structures were used by the Senior Center. In front of the building along Beach Street, a major portion of the terrazzo sidewalk was settling, creating uneven surfaces and surface cracks.

On January 3, 1978, Aquatic Park was transferred to the Golden Gate National Recreation Area, becoming a unit of one of the country's first major urban national parks. The Maritime Museum remained a separate entity until June of 1978, when it too became part of the National Park Service and was joined with the historic ships of the State Historic Park to become the National Maritime Museum of San Francisco. (Figure 37)

**Figure 37** View of Aquatic Park, ca. late 1970s. View looking southwest. (San Francisco Maritime NHP, *Historic Documents*, A12.40, 891n)



The National Park Service (NPS) inherited a number of maintenance issues associated with the buildings and use of the park. Work under the NPS initially focused on stabilization of structures and moderate upgrades such as repainting the shower rooms and the exterior of the Bathhouse, and repairing broken windows. Security bars were installed outside the windows of the former medical facility in the bleacher area, allowing the structure to serve as a lifeguard office with rescue equipment, a supply locker, a first aid station, and showers. One major alteration was the installation of new doors to the men's and boy's shower area. In addition, the beach was cleaned and trash cans were installed throughout the park. Planting beds were weeded and replanted. Two temporary plywood lifeguard towers were erected, and seawall street lamps were repaired. At Victorian Park, lawns were reseeded and planting beds were supplemented with additional plant materials. Along Van Ness Avenue, parking meters were removed permitting public parking. (Figure 38)

**Figure 38** The Cable Car system with a turnabout in Victorian Park, was designated a National Historic Landmark in 1964 and remains a popular destination for visitors today. (NPS, 2009)



In July 1978 the Golden Gate National Recreation Area eliminated entrance fees to the museum and on the first day of free admission, 1,111 people visited the museum, compared to 300 visitors the day before. Subsequent attendance statistics revealed that visitation increased 200 to 300 percent from preceding years.

In 1984, the historical significance of the Aquatic Park Bathhouse and associated structures was recognized and Aquatic Park was listed in



the National Register of Historic Places as a historic district. Just three years later, in recognition of its national significance, Aquatic Park was designated a National Historic Landmark. Then, on June 27, 1988, Congress passed Public Law 100-328 establishing San Francisco Maritime National Historical Park, comprising the maritime museum, park areas, and the historic vessels. And finally on July 18, 2003, management of the San Francisco Municipal Pier was transferred from Golden Gate National Recreation Area to San Francisco Maritime National Historical Park.

Today the San Francisco Maritime National Historical Park continues to preserve the maritime heritage of the nation, and acts as the custodian of Aquatic Park, a unique National Historic Landmark and public resource along the San Francisco waterfront. (Figure 39)

**Figure 39** The San Francisco Maritime National Historical Park sign located in the northeast corner of Victorian Park. View to Aquatic Park, looking west. (NPS, 2006)







# Historic Base Map

Figure 40

### Sources

1948 Aerial Photograph Aquatic Park, Historic Documents, Historic Photograph Collection, San Francisco Maritime National Historical Park, Google Earth; San Francisco History Center, San Francisco Public Library.

### Notes

Information depicted on the Historic Base Map is based on analysis and consolidation of information in aerial photographs and historic photographs showing Aquatic Park at the end of the period of significance.

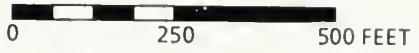

## Cultural Landscape Report: Aquatic Park

San Francisco Maritime  
National Historical Park  
2010

National Park Service  
Pacific West Region  
Cultural Landscape Program





# Historic Base Map

Figure 40



## Sources

1948 Aerial Photograph Aquatic Park, Historic Documents, Historic Photograph Collection, San Francisco Maritime National Historical Park, Google Earth; San Francisco History Center, San Francisco Public Library.

## Notes

Information depicted on the Historic Base Map is based on analysis and consolidation of information in aerial photographs and historic photographs showing Aquatic Park at the end of the period of significance.

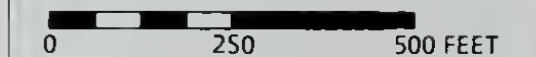

## Cultural Landscape Report: Aquatic Park

San Francisco Maritime  
National Historical Park  
2010

National Park Service  
Pacific West Region  
Cultural Landscape Program





## Endnotes

### Site History

1 Several sources document the character and material culture of these settlements as summarized and noted by Amy Hoke and Eliot Foulds in *Cultural Landscape Report for Fort Mason, Golden Gate National Recreation Area, Volume One: Site History, Existing Conditions, and Analysis*, (Brookline, Olmsted Center for Landscape Preservation, National Park Service, 2004): p.16-17.

2 The name Black Point may have been derived from the dark evergreen foliage that grew on the point and stood out in contrast to the gray, lighter-green foliage of the coastal scrub plant communities located nearby.

3 See James P. Delgado, *Historic Structures Report, Historical Data Section. Pioneers, Politics, Progress and Planning: The Story of San Francisco's Aquatic Park, Draft*, (National Park Service, 1981): p. 8-9

4 See Delgado: pp. 4, 10, and Gerald R. Dow. "Bay Fill In San Francisco: A History of Change" (Master's thesis, California State University, San Francisco, 1973): pp 62, 70.

5 Because of the steep underwater slope that allowed access to offshore ships, developers valued the San Francisco shoreline including the north shore of Black Point Cove. As described in Dow: p. 62-63, prior to modification of the shoreline in the late 1850s, Black Point Cove covered a larger area than what exists today with the shoreline extending along a narrow strip of beach that stretched from North Point, at the foot of Telegraph Hill to Black Point. This part of the shore would only have been useful for shipping if cove had been filled out to deep water and the port seawall extended. Black Point cove extended from Black Point on the west to Sand Point, foot of Hyde Street, on the east.

6 See the Sanborn Map Company's Insurance Maps of San Francisco, California, Volume One (New York, Sanborn Perris Map Company, 1899).

7 This structure is depicted on 1867 maps of the area in the approximate location of the present-day east portal to the Fort Mason railroad tunnel.

8 See Delgado: p. 42-43.

9 The Dolphin Club building was built at the site while the others were moved in by barge. See James Delgado, *Pioneers, Politics, Progress and Planning: the Story of San Francisco's Aquatic Park* (1981): p. 37-38.

10 See Anna Cox Toogood, *Historic Resource Study: The Bay Area Community, A Civil History of the Golden Gate National Recreation Area, Volume 2* (Denver, National Park Service, 1980) p. 117, 120.

11 See Olmsted et al., *Preliminary Report In Regard to a Plan of Public Pleasure Grounds for the City of San Francisco* (New York, William C. Bryant & Company for Olmsted, Vaux & Company, 1866). Quoted in Delgado: p. 49)

12 See Delgado: p. 51.

13 See Toogood: p. 122.

14 See Toogood: p. 124-25.

15 San Francisco city Architect William A. Mooser Sr. appraised the lands for this exchange. Mooser was employed by the engineering firm of Punnett, Perez & Hutchinson during the WPA project at Aquatic Park, and supervised the WPA draftsmen in the development of construction drawings for the Aquatic Park buildings. See Delgado: p. 55

16 See Toogood: p. 127 and Delgado: p. 56.

17 This plan was essentially the same as Punnett's 1913 site plan developed for the Aquatic Park Committee. For the design competition the boundaries of the park included "the area at the foot of Van Ness Avenue bounded by Van Ness Avenue, Larkin Street, Beach Street, and Jefferson Street, together with that which lies to the north of Jefferson Street between Fort Mason and Hyde Street; although at this point the city did not own nor control all of this land. See the San Francisco City Bureau of Engineering Annual Report" (1920).

18 The firm of Bakewell & Brown was founded in 1905 by John Bakewell, Jr. (1872-1963) and Arthur Brown, Jr. (1874-1957). At the time of the design competition Bakewell & Brown was a prominent San Francisco architectural firm with considerable experience throughout the San Francisco Bay area. John Baur, also a successful San Francisco architect, joined the firm as part of the design team for the competition.

19 See the San Francisco City Bureau of Engineering Annual Report (1921-22), Delgado: p. 56-57 and Toogood: p. 131.

20 See the San Francisco City Board of Supervisors, Proceedings (1927): p. 1437.

21 See the Journal of Proceedings, San Francisco Board of Supervisors, City and County of San Francisco, (Dec. 21, 1931: p. 3459).

22 Although work stopped, the structure had not reached its present form. The rounded terminal end and convenience station were not built. (Toogood, Vol. II: 137).

23 See Toogood: p. 137-38.

24 National Archives, Record Group 69, WPA, Box 902, California file 651.109, Aquatic Park, San Francisco (1935).

25 See Toogood: p. 140.

26 See William Mooser, Jr., Report on Progress of the Works Program in San Francisco, San Francisco, Works Progress Administration, 1938. As in other cities, a major component of the WPA work in San Francisco related to the development of parks and recreational facilities. In a 1916 national survey of 36 large cities, San Francisco ranked 26th in the amount of parkland relative to its population with only 10 playgrounds and two swimming pools for the entire city. Between 1935 and 1937, the WPA spent over \$8,100,000 on park and recreation projects in San Francisco. The efforts of the WPA related to park and recreational facilities in San Francisco had an immediate and lasting effect. In addition to the work at Aquatic Park, other park projects undertaken by the WPA in San Francisco included work at Balboa, Bay View, Buena Vista, Golden Gate, Harding, Inspiration Point, McLaren, Mount Davidson, Sharps, and Telegraph Hill parks, the Marina

seawall, Park Presidio through Golden Gate Park, and exhibits for the Zoological Gardens.

27 WPA 1939, 15, 25.

28 William Mooser Jr. was the third generation of his family to practice architecture in San Francisco. The use of suffixes for the three William Moosers, all architects in San Francisco, can lead to some confusion. The first William Mooser was an architect and practiced in San Francisco between 1860 and 1898. His son, William Mooser, Jr., trained as an engineer and then took over the family's architectural firm after his father's death. He was appointed as the first San Francisco City Architect in 1902, and established the San Francisco City Bureau of Buildings and implemented building codes for construction in San Francisco. He is perhaps best known for his designs of the Bathhouse and other buildings in Aquatic Park and the courthouse in Santa Barbara, California. By the mid-1930s, during the WPA project, William Mooser III, his son, identified himself as "William Mooser Jr." and his father was known as "William Mooser".

29 See Donald J. Bush, *The Streamlined Decade* (New York, George Braziller, Inc. 1975): p. 133.

30 See Bush, pp. 138, 148, 149.

31 See WPA, pp. 2, 11, 15, 23, 25, and 27.

32 No additional information on Grabow was located during this report, although by August 1941 his name appears as the city Director of Engineering and Landscape Design.

33 See Delgado: p. 63.

34 The sculptures of Beniamino Bufano were part of the Federal Arts Project at San Francisco. Bufano was commissioned to create 11 sculptures for Aquatic Park. Red granite sculptures designated for the esplanade of the Bathhouse included a crab, turtle, fly, seal, snake, bear, frog, snail, and two fish. A torso and one grouping of mother and children were proposed for the interior of the Bathhouse (WPA, 1938). The installation and location of the sculptures during the period of significance remains unclear. What is clear is that by the official opening of the park in January 1939, none of the Bufano sculptures were in place.

35 The city also submitted an application to the state WPA administration to complete the tile work at the Bathhouse and the convenience station on the Municipal Pier, remove the Black Point Pumping Plant, and construct a playground. The proposal was rejected.

36 See Mieldazis (1939): p. 12-13.

37 See Delgado (1981): p. 93-94. Tidal action continues to affect the beach today. The NPS re-grades the beach as needed.

38 See the "General Plan of Auto Parking Areas and Park for Aquatic Park," Drawing #3737-A, SAFR #HDC B15-6.

39 See Drawing #HCD 555,B5.15-7.

40 See Delgado: p. 83-84.

41 This wharf was located in an area identified in Punnett's 1936 plan as the location for rowing club boathouses. The same facility, later remodeled, now serves as the Sea Scout building in Aquatic Park.

42 See Delgado: p. 85.

43 See Delgado: p. 85-86 and Toogood: p. 158.

44 A pumping plant was first built in this location by the San Francisco Water Company (later the Spring Valley Water Works) ca.1857. Water from Lobos Creek in the Presidio was conveyed by flume and tunnel to the Black Point plant. From there water was pumped to the Lombard Street and Francisco Street reservoirs for distribution in the city. The city purchased the Spring Valley Water Works system in March 1930 and with it, the Black Point Pumping Plant. By then, changes in water sources eliminated the need for this pumping plant. By 1938, the plant was no longer used and the machinery was removed. See the San Francisco Public Utility Commission Annual Report (1939-1940).

45 Dates for removal of the pumping station differ. Delgado states that the pumping station was demolished in the "late 1940s"; however, records from the City of San Francisco indicate the structure was removed by 1940. See Delgado: p. 95 and the San Francisco Public Utility Commission Annual Report, 1939-1940.

46 In 1952, prompted by the unsanitary swimming conditions in the cove, the city proposed building an indoor swimming pool at the site. See Delgado: p. 89.

47 The army relinquished its lease and returned Aquatic Park to the city in February 1948. An aerial photograph from July 1946 shows a bocce ball area suggesting that the open area southwest of the Bathhouse was adopted quickly. Use of this area by bocce ball players may predate the army. According to a newsletter for the United States Bocce Federation, the Aquatic Park Bocce Club was founded in the 1950s by Italian immigrants who met at the park to play ball.

48 See Pacific Aerial Survey: 1946, and 1948; San Francisco Maritime National Historical Park, Museum Plans Collection, Kortum photographs, 1952.

49 See Delgado: p. 96.

50 See Delgado: p. 95-96 and George Quesada, Facilities Development, Bocce Ball Courts Phase II, Southwest Area, Aquatic Park, Beach St and Van Ness Ave., San Francisco, 3 Sheets, 1960.

51 See Pacific Aerial Survey: 1969 and 1977.

52 See Delgado: p. 89.

53 See City and County of San Francisco, Board of Park Commissioners, Division of Engineering, 1940, 1941.

54 See Delgado: p. 87.

55 See Karl Kortum, "Background of the Victorian Park" 1963, typed Manuscript, Karl Kortum Collection, San Francisco Maritime National Historical Park, Museum Plans Collection.

56 See Toogood: p. 209. The extension of the cable car line into the block was financed by a Public Utilities Commission Bond issue passed in 1954.

57 Karl Kortum, Letter to Aubrey Neasham, Historian, California Division of Beaches and Parks, October 1, 1959.

58 Ibid.

59 See California State Department of Natural Resources, Division of Beaches and Parks, 1958 and 1959; California State Department of Public Works, Division of Architecture, 1961.



60 Because the Church drawing has not been located, plant materials he may have specified and how they were incorporated into the 1961 design by the state are not known.

61 This bed separates the sidewalk along Beach Street and the plaza area in Victorian Park. People use this bed as a shortcut and social trails have developed. In addition, the *Agapanthus* had become something of a hazard, with trash collecting in the undergrowth attracting rodents.

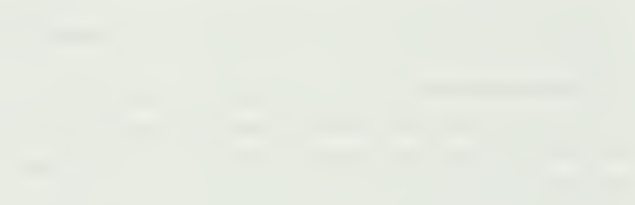

## Existing Conditions

Aquatic Park is located in San Francisco Maritime National Historical Park, situated at the west end of Fisherman's Wharf in San Francisco, California. Vehicular access to the park is limited to Beach Street, Jefferson Street, and a short access road along Van Ness Avenue as it extends north to the Municipal Pier. (Figure 41) Street parking for visitors is provided in this area. Key circulation features in the park include the Beach Promenade around the cove, Van Ness Avenue, ramped walkways on both sides of the Bathhouse building, sidewalks on the upper terrace east of the Bathhouse, and the terrazzo sidewalk at the entrance to the Bathhouse on Beach Street.

As designed, and with few exceptions, land use activities in Aquatic Park remain focused on passive recreation, centered on the Aquatic Park Cove. The Beach Promenade remains a popular area for public use and access to the water as well as for walking and sightseeing. Open lawn areas between Beach Street and the Bathhouse bleachers provide space for a variety of recreational uses and create a transition between the city street grid and the park. The sidewalk along Beach Street defines the south boundary of the park, and connects with other paved walkways leading to the lower levels of the Aquatic Park including Van Ness Avenue and the Bocce Ball

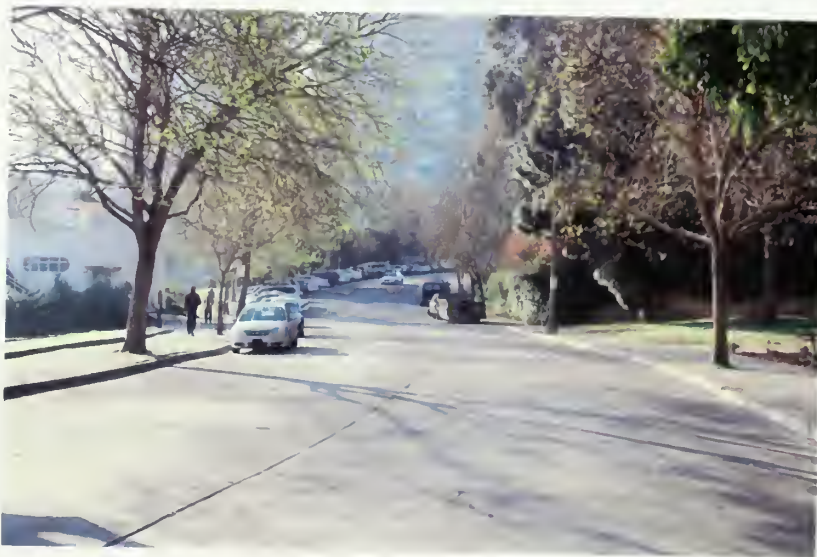

**Figure 41.** Van Ness Avenue provides access to the park and is a primary parking area for park visitors. View looking south. (NPS, 2007)



**Figure 42.** The Beach Promenade along the shoreline of the cove is the primary pedestrian access through the park. View looking northwest. (NPS, 2007)



Courts on the west, and Victorian Park on the east. Businesses related to the tourist industry dominate the neighborhoods east and south of Aquatic Park.

The primary historic structures in Aquatic Park are located around the shoreline of the cove and are oriented towards the water and the Beach Promenade, which follows the shoreline from the east boundary of the park to Van Ness Avenue. (Figure 42) The Municipal Pier extends out along the northwest side of the cove. It is used by park visitors for a variety of recreational activities such as sightseeing, photography, strolling, and fishing. (Figure 43)



**Figure 43.** View to the Municipal Pier as it arcs around Aquatic Park Cove. Fort Mason Pier 4 in the foreground. View looking northeast. (NPS, 2007)

All of the structures built during the period of significance remain in the park today. These include: the Municipal Pier, the Bathhouse, the east and west bleachers, the East Convenience Station, West Convenience Station, the East Speaker Tower and West Speaker Tower, the seawall, beach promenade retaining wall, a concrete retaining wall retaining a planting bed on the west side of the Bathhouse, and the basalt block retaining wall (with stone acorns) located on the west side of the upper terrace near the Bocce Ball Courts. The Sea Scouts building, constructed by the army during World War II, also remains. A low concrete retaining wall, added after the period of significance, is located on the west side of West Bleachers.

Structures associated with the bocce ball courts are situated in the southwest portion of Aquatic Park including two courts and a small wood-frame building used by the Aquatic Park Bocce Ball Association as their clubhouse. (Figure 44)

A number of structures are also located in Victorian Park. Primary among these are the cable car turnaround, a ticket booth and kiosk, a metal-frame gazebo at the east end of the plaza, concrete retaining walls along Beach and Hyde streets, and a retaining wall on the east edge of the park enclosing a magnolia tree.

Lawn is the dominant cover for open spaces within the park. It is used throughout the upper terraces west and east of the Bathhouse, while planting beds throughout the park contain a mix of shrubs and perennials. Grecian laurels (*Laurus nobilis*) are planted around the base of the East Speaker Tower and the West Speaker Tower. Other plants in this area include a Monterey cypress, and a mix of shrubs and perennials planted against the wall wrapping around the southeast side of the east bleachers. On the north side of the Bathhouse, individual juniper shrubs remain in the small planting beds adjacent to the building.

North and west of the Bocce Ball Courts, planting beds include a mix of small shrubs, perennials, ivy, and overgrown blackberry. Currently (2009), the area east of the courts is used as a construction staging area for the bleacher rehabilitation project. An *Escallonia* hedge extends along the north side of the basalt block retaining wall. A row of towering Lombardy poplar trees (*Populus nigra* 'italica') line the north edge of the park west of the Bathhouse.



**Figure 44** View of the overhead structure covering the Bocce Ball Courts located in the southwest corner of the park. (NPS, 2007)

**Figure 45.** Sweeping lawns characterize the north side of Victorian Park. View looking west toward Aquatic Park. (NPS, 2007)



**Figure 46.** View of the pedestrian plaza along Beach Street in Victorian Park. View looking east. (NPS, 2007)



London plane trees (*Plantanus acerifolia*) line both sides of Van Ness Avenue, creating a canopied corridor to the Municipal Pier. The area west of Van Ness Avenue (referred to as the “pocket park”), includes three earthen berms, a lawn area, and Canary Island pines along with other trees planted in the lawn.

In Victorian Park, vegetation is characterized by relatively large areas of lawn and planting beds with a mix of perennials and low shrubs. (Figure 45) A pedestrian plaza connecting the cable car turnaround with Aquatic Park is planted with a mix of perennials. *Cordyline* are located on either side of the central bed. A dense planting of *Agapanthus* and a row of cherry trees (*Prunus sp.*) are planted along Beach Street. (Figure 46) North of the pedestrian plaza and cable car area, a turf-covered slope sweeps down to Jefferson Street. In the northeast corner of the lawn area are five, large monkey puzzle trees (*Araucaria araucana*). A row of *Arbutus* ‘Marina’ trees are on the north side of the park along the sidewalk. A large magnolia (*Magnolia grandiflora*) tree with a commemorative plaque honoring Friedel Klussman and her effort to save the cable car system is located on the southeast corner of Victorian Park.



Small-scale features in Aquatic Park include both historic and non-historic elements. Historic small-scale features include concrete lampposts with metal collars along the Beach Promenade and the Municipal Pier (one is located on Beach Street near the Bocce Ball Courts); several formed concrete benches along the length of Municipal Pier; welded-steel tube railings along the front and the sides of the east and west bleachers; and stone curbing. Non-historic features include light fixtures, benches, trash cans, bollards, water fountains, fencing, signs, interpretative and commemorative features, anchors, propellers (placed in planting beds), a MUNI bus shelter, a mailbox, and a metal bike rack. (Figure 47)

**Figure 47** Examples of historic, non-historic, and compatible small-scale features located throughout Aquatic Park. (NPS, 2007-9)



1

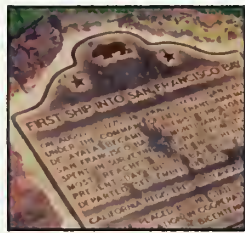

2



3



4



5



6



7



8



9

- 1. Historic basalt curbing near the Sea Scout building along the Van Ness Avenue sidewalk.
- 2. California State Historical Landmark plaque commemorating the 1775 arrival into San Francisco Bay of the Spanish vessel *San Carlos*.
- 3. Historic concrete bench along the Municipal Pier.
- 4. Restored [historic] terrazzo paving in front of Bathhouse, and compatible accessibility ramp
- 5. Historic [above ground] remnants of the stone masonry wall piers near the Bocce Ball Courts.
- 6. Non-historic but compatible bench near the East Convenience Station.
- 7. Non-historic and incompatible drinking fountain.
- 8. Maritime interpretive feature near East Convenience Station.
- 9. Non-historic commemorative fountain located near the Bocce Ball Courts.



# Existing Conditions

Figure 48

## Sources

Field documentation 2005-2009;  
2005 Aerial photograph, Pacific Aerial  
Surveys: Google Earth

## Notes

Existing conditions field documentation in 2009 takes into account only a portion of the renovations associated with the Bleacher Rehabilitation project including the reconfiguration of the skylights and associated planting areas behind the east and west bleachers.

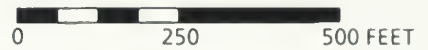

## Cultural Landscape Report: Aquatic Park

San Francisco Maritime  
National Historical Park  
2010

National Park Service  
Pacific West Region  
Cultural Landscape Program





# Existing Conditions

Figure 48

### Sources

Field documentation 2005-2009;  
2005 Aerial photograph, Pacific Aerial  
Surveys; Google Earth

### Notes

Existing conditions field documentation in 2009 takes into account only a portion of the renovations associated with the Bleacher Rehabilitation project including the reconfiguration of the skylights and associated planting areas behind the east and west bleachers.

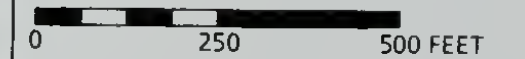

## Cultural Landscape Report: Aquatic Park

San Francisco Maritime  
National Historical Park  
2010

National Park Service  
Pacific West Region  
Cultural Landscape Program





# ANALYSIS AND EVALUATION

## Introduction

The evaluation of cultural landscape characteristics is documented in the Cultural Landscapes Inventory for Aquatic Park (CLI). Portions of the following evaluation are excerpted from the CLI, and are supplemented with additional information based on research conducted for this report. The focus of the analysis and evaluation is on the cultural landscape characteristics and features that support treatment recommendations. Landscape characteristics that contribute to the designed landscape of Aquatic Park are described in the following sections:

- *Topography*—Describes the purposeful grading of the site to create the open and terraced ground plane stepping down to the cove.
- *Buildings and Structures*—Describes the structures as an expression of a distinct architectural style, and the relationships between buildings and the designed landscape.
- *Circulation*—Describes the designed systems that allow pedestrian movement through the park, connecting to adjacent areas.
- *Vegetation*—Describes the overall character of ornamental plantings as a reflection of the Streamlined Moderne style.

For each of these characteristics, the historical significance and physical integrity is documented and evaluated in order to identify the landscape features and attributes that contribute to the significance of Aquatic Park and define its historic character.<sup>1</sup>

## Topography

### Modification of the Natural Setting

Historically Black Point Cove occupied a surface area somewhat larger than what exists today. The original shoreline extended south of today's Beach Street. The steep cliffs of Black Point created the western boundary, and to the east, Sand Point (the Argonaut Hotel and park visitor center

marks approximately where the end of Sand Point would have been). At the time that the first major alterations to Black Point Cove began around 1860, both the Pioneer Woolen Mills and San Francisco Water Company were expanding operations by adding fill material to the shoreline. In an equally dramatic move, the Selby Smelter leveled Sand Point Bluff at the foot of Hyde Street and dumped it into the bay. These expansions of the waterfront forever altered the natural character of the shoreline. By 1900 approximately half of the block north of Beach Street between the alignments for Larkin Street and Van Ness Avenue had been filled, and in the southwest corner of the cove, wharves extended out to the (underwater) alignment for Jefferson Street.<sup>2</sup> Perhaps even more dramatic changes to the shoreline came as a result of the extensive dumping of debris, following the 1906 San Francisco earthquake and fire. The extent of fill materials from this operation is not known, but accounts from the period report that 15,000 truckloads of red brick rubble from the Palace Hotel dumped along the shore, which “utterly ruined” the beach area.<sup>3</sup>

#### *Grading the Designed Landscape*

Based on an early design drawing for Aquatic Park, initial grading focused on three areas of the site. One area was designated a “rock fill” leading from the current location of Victorian Park to the shoreline. This fill operation was completed by 1914 using debris from the railroad tunnel cut through Black Point. The second area, also designated as “rock fill”, was located along what is now the north end of Van Ness Avenue. This undertaking appears to have extended the shoreline approximately 30 feet out into the bay, creating the landform that would ultimately connect with the Municipal Pier. This fill work was completed by the military in 1913, connecting Van Ness Avenue with McDowell Road into Fort Mason. The third area of initial grading was a “top of bank” contour running along the entire length of Black Point Cove. The grading required for this structure called for a drop from the existing grade to the beach below. If this structure ever was constructed, it was most likely obliterated in 1920 during grading operations for the construction of Aquatic Park.<sup>4</sup>

Site development and construction of Aquatic Park between 1931 and 1936 required extensive grading to create building sites and an integrated ground plane. Excavations for the Bathhouse in the central portion of the park site dominated construction along Beach Street between Polk and Larkin streets. Carved into the slope, the building was sited and the

landscape graded so that the main entry to the building would meet grade at Beach Street, and the entry on the north side of the building was at the same grade as the Beach Promenade. Some fill was added along Beach Street for a parking area. The excavation and grading for the Bathhouse was the central topographic influence on subsequent grading and the placement of structural retaining walls at the park. (Figure 49)

In addition to the seawall, which defined the shoreline of the park, retaining walls were used throughout the site to create a stepped grade around the cove, and topographic transitions from the cove to Beach Street. A concrete retaining wall was built on the south side of the Beach Promenade and a basalt block retaining wall was built just north of the Black Point Pump House. Fill was added between these two walls, and the slope graded so that the elevation decreased from the basalt block wall to the Beach Promenade wall, tapering towards the west side of the park, where the grade met the edge of Van Ness Avenue. In 1938, the large structural terraces on both sides of the Bathhouse were leveled and seeded with grass. Sloping walkways and steps were used to create transitions and allow pedestrian access between the terraces and down to the Beach Promenade. (Figure 50)



**Figure 49.** WPA photograph showing the retaining structures required prior to relocation of the State Belt Railroad tracks. (*San Francisco Maritime NHP, Historic Documents, Photograph Collection, SAFR-N-2-26*)



**Figure 50** Detail of WPA photograph showing the number of topographic modifications to the slope around the cove that were part of the site design and construction of Aquatic Park, 1938 (*San Francisco Maritime NHP, Historic Documents, Photograph Collection, P88-035.00139*)





In order to create a gently sloping recreational beach along the cove, 24 railcar loads of sand (from beaches in Monterey) were added to the shoreline north of the seawall. Within several years however, a severe storm removed all of this sand, and in July 1941, 80 million cubic feet of sand from construction excavations of the Union Square Parking Garage were hauled to the Aquatic Park beach, further extending the shoreline into the cove.<sup>5</sup> This fill reestablished a broad, clean sandy beach in place of the exposed rubble-filled shoreline. (Figure 51)

**Figure 51.** Sand distributed on the bathing beach in Aquatic Park, 1941. View looking west. (Courtesy of the San Francisco History Center, San Francisco Public Library, AAA 6701)

### *Current Topography*

Today, the primary topographic features defining the physical landscape of Aquatic Park include the broad, level terraces on the east and west sides of the Bathhouse, the ramped walkways, and the gentle uphill slope from the shore of the cove toward Beach Street. Low tide exposes the extent of the sloping sand and rubble beach, defined on the south by the seawall. The seawall also forms the base of the promenade that runs the entire southern edge of the beach within the district. On the western end of the district, the promenade extends as a pathway to Van Ness Avenue, where it meets the grade at the street, continuing to the end of the Municipal Pier. The grassy strip that abuts the retaining wall on the eastern boundary of Fort Mason (the western boundary of the Aquatic Park Historic District) has a mildly undulating surface. At the southeastern edge of the district, the grade above the seawall follows the level, paved extension of Jefferson Street westward to the footpath east of the east bleachers. Above the bleachers and Bathhouse, the grade levels again, forming an upper terrace adjacent to Beach Street.

### **Summary**

Modification of the topography around Black Point Cove for commercial development in the late 19th Century, and subsequent grade changes as a result of use by the U.S. military, significantly altered the natural contours of the landscape. Beginning in 1922, John Punnett's landscape plans for the new Aquatic Park, called for a series of level terraces wrapping around the shoreline, creating a narrow bowl-shaped park. This design as implemented between 1936 and 1939 by the WPA, accommodated the increase in elevation between the cove and Beach Street (north to south) and allowed the extent of designed park development to fit within the existing street grid surrounding the site (to the east and south). Landscape terraces were





**Figure 52.** Current view of Seawall around the cove stepping to the Beach Promenade and the slope above to the Upper Promenade. View looking west. (NPS, 2006)

stabilized by constructing retaining walls and adding fill to create level terraces and sloping planes. Pedestrian movement through the park was structured by transitions between these terraces and grade changes, using ramped walkways and steps. (Figure 52)

Although some minor alterations to the original grades have occurred over time, the location and extent of the designed terraces, and the relationship between the ground plane and structures remains with a high level of integrity, and contributes to the historic character of Aquatic Park.

## Buildings and Structures

Designed in a unified style and constructed in a concentrated period, the buildings and structures in Aquatic Park reflect a very definitive architectural character within the park. All of the contributing buildings in Aquatic Park are designed in the Streamlined Modern style. Architectural characteristics associated with this style reflect, to a degree, the aesthetics of the machine age. Architectural details such as curved roof lines and rounded corners of buildings often have a strong association with the line and style of airplanes and ships designed during this period using modern aerodynamic engineering principles. Characteristic details of

Streamlined Moderne structures includes flat and curved walls, use of glass blocks especially in the curved walls and around entrance ways, tubular metal railings (mimicking ship railings), and circular windows to balance rectangular elements. <sup>6</sup> The historic structures and buildings in Aquatic Park exhibited all of these characteristics.

All of the buildings and structures listed below contribute to the significance of the historic district. Unless otherwise noted, descriptions and technical information are compiled or excerpted from the Cultural Landscapes Inventory, Aquatic Park, San Francisco Maritime National Historical Park and the List of Classified Structures San Francisco Maritime National Historical Park, and Golden Gate National Recreation Area. Park building numbers and LCS numbers for specific structures are compiled in Appendix B. Some structures, such as roads and walkways, are discussed as components of circulation.

### Bathhouse

The Bathhouse is the central structure of Aquatic Park, designed by William Mooser Jr. in the Streamlined Moderne style. (Figure 53)



**Figure 53** The Bathhouse today, view looking west. (NPS, 2010)

Construction on the Bathhouse began in 1936 and was completed in 1939. It currently houses the San Francisco Maritime National Historical Park Museum and the San Francisco Senior Center.

The Bathhouse is concrete and steel frame construction. It is 125 feet long and elliptical in plan; its rounded ends are largely glazed with metal sash. In profile it assumes a three-tiered form. Although the building contains four levels, only three are visible from Beach Street; the lower level is below street grade and opens to the Beach Promenade. The third and fourth stories are set back on a deck-like terrace with metal railings. The flat fourth-floor roof is decorated with four “masts,” or flagpoles, which surround a larger central flagpole. Air vents on the roof were designed in the shape of ship funnels. A carved bas-relief green slate entrance canopy and door surround defines a central, recessed entrance on the Beach Street (south) elevation. The Beach Street entrance features three sets of glass doors with brass-plated handles shaped like halves of ship’s wheels. Glass transom windows span the entry doors. The entrance is flanked on either side by three vertical metal sash windows and three “porthole” windows. The concrete exterior walls of the building are painted white. A WPA report described the building as, “... a huge ship at its dock... with rounded ends, set back upper stories, porthole windows and ship rails, its resemblance to a luxurious ocean liner is indeed startling.”<sup>7</sup>

The interior of the Bathhouse is lavishly decorated and features many original artworks with nautical motifs executed by various artists working under the auspices of the Federal Arts Project of the WPA. (Figure 54) The murals were completed by Hilaire Hiler, Richards Ayers, Charles Nunemaker and others, bas-relief sculptures and tile mosaics were by Sargent Johnson, animal sculptures by Beniamino Bufano, and light fixtures by John Glut. Hiler supervised the overall design of the building interior. The interior decorations repeat the maritime themes of the building’s exterior: a terrazzo floor is designed to represent a nautical chart of San Francisco Bay, and murals in the main lounge depict highly stylized undersea scenes.

In the years following construction of the Bathhouse, several alterations were made to both the interior and exterior of the structure. In 1947 the San Francisco Senior Center moved into the lower floors of the Bathhouse. Soon funds were obtained to renovate the building and install an elevator to the second floor. The elevator was installed in the east end of the open



**Figure 54** Recent conservation work was completed on the Hilaire Hiler underwater seascape murals in the lobby of the Aquatic Park Bathhouse. (NPS, 2008)



portico on the rear, north side of the Bathhouse, and necessitated removal of the Blue Room vestibule. Care was taken to repair the terrazzo floor to imitate the original design. These alterations date to circa 1963.

Additional work consisted of remodeling the Blue Room, the former restaurant and first maritime museum into the “Bayview Room,” which now functions as a community recreation hall and catering kitchen to serve meals for seniors. Alterations to the building interior in this area consisted of removing painted wooden plaques that had been mounted at the top of the room’s wall and represented the flags of various yachting clubs. (These flags were added to the park museum collection). The room was also repainted from its varied shades of blue (hence the name) to white, and an original window at the sidewalk level was removed and replaced with a new wheelchair-accessible door.<sup>8</sup> On the first floor, portions of the shower and dressing areas located under the bleachers were converted into offices and classrooms separated by plywood walls. The former concession stand, which occupied the central room, was also removed. The four pillars that served as the corners of the concession counter still stand, now sheathed in paneling.

Use of the Bathhouse by the San Francisco Maritime Museum also led to several alterations, including removal of original elements. In fact the entire eastern half of the third floor was radically modified in 1976 to better suit museum needs; two wing walls were installed to create exhibit bays and false walls were installed over original artwork. Some of the alterations included replacement of the original stairway banisters, which consisted of rope with brass ends, with chrome metal railings. One bathroom was converted into office space, and the glass block wall pantry was remodeled to function as a library, with internal wooden walls and a shelving system. The library was converted to an exhibit space—the Harmon Gallery, in 1984. Recently (2007/2008) this gallery space was rehabilitated to serve as the lobby for a new elevator. In addition, the “yardarm” attachment on the flagpole, or “main mast” on the fourth-floor roof was removed, and four [original] perimeter flagpoles were added. The 1976 work on the third floor damaged and covered much of the artwork on the walls that was designed by Richard Ayers. Affected were the multicolored murals and the three-dimensional design elements constructed of plywood, string, and metal. A carpet was glued over the colorfully designed terrazzo floor on the eastern half of the room.





**Figure 55** Rehabilitation work at the Bathhouse in 2008 included the installation of a new stainless steel window system; and a modern waterproofing system for the building roofs with new roof tiles to match the historic ones that could not be salvaged. The rehabilitated glass block pantry is now the elevator lobby on the 3rd floor. (NPS, 2008)

In 1993 the park installed covers over the existing skylights on the building's exterior. The reversible covers were installed to prevent water leakage into the basement of the Maritime Museum where offices, workshops, and a photographic darkroom are located. In 1998, a portion of the women's shower room was rehabilitated into a park maintenance office, workshop, and tool storage area. The space was redesigned in 2009 to serve as office space for the Park Ranger staff.

The most recent renovations to the building include replacement of 90 percent of the windows and doors in the building with a new system that preserves the appearance of the original design and conservation of the wall mural in the lobby. (Figure 55)

### East and West Bleachers

Concrete bleachers flank the east and west sides of the Bathhouse and beneath them are the former shower and locker rooms that create a continuous ground floor with the lowest level of the Bathhouse. Streamlined Moderne style details are incorporated into the bleacher wing walls. The East Bleacher structure, which measures 65 x 250 feet and with 11 rows for seating, is the larger of the two structures. It is composed of two parts separated by a driveway and entries into the structures below, and is generally known as the center and east bleachers for clarity's sake. The space under the center bleachers was originally the men's and boy's

**Figure 56.** East Bleachers prior to rehabilitation work. View looking east. (NPS, 2007)



shower facility. It is now used for the park’s exhibit staff office, workshop, and storage. The space under the East Bleachers includes the original hospital that was used by the NPS as a lifeguard station and now as an office for the facility management division. The rest of the space under the East Bleacher is used for a metal shop, machine shop, and facility maintenance storage. The West Bleacher measures 30 x 100 feet and comprises four rows of seats. The space beneath the West Bleacher is used as a ceramics studio by the Senior Center and was formerly office, work and storage space for the park’s grounds crew. Once the bleachers are rehabilitated, grounds crew will move into the East Bleachers and their former space will become offices for park rangers. (Figure 56 )

Constructed in 1938, the bleachers were originally intended to seat “many thousands who desire to watch athletic events, races and the large crowd at play...”<sup>9</sup> The bleacher seats are now the setting for outdoor events and serve as informal seating for park visitors. The East Bleachers originally accommodated the Aquatic Park hospital and first aid station beneath its benches.

**Figure 57.** West Bleachers prior to rehabilitation. Note the ramp between the bleachers and the Bathhouse. View looking southwest. (NPS, 2007)



Between the Bathhouse and the bleachers, vehicular ramps lead from Beach Street to the Beach Promenade. (Figure 57) These ramps curve around the east and west ends of the Bathhouse, and repeat the elliptical forms characteristic of the complex of buildings and structures in Aquatic Park. Metal handrails, similar to those forming the Bathhouse parapet rails, separate the bleachers from the Beach Promenade and line the entryway, in the center of the east bleachers to the Bathhouse changing rooms.

### West Convenience Station

The West Convenience Station is located on the west side of the park near Van Ness Avenue and the approach to the Municipal Pier. The building originally contained a concession stand and restrooms. Today the concession stand is not used and the restroom fixtures have been removed so that the building can be used to store facility management supplies and materials during the bleacher rehabilitation project. The building was constructed by the WPA and architecturally reflects nautically inspired Streamlined Moderne style elements similar to other park buildings. (Figure 58) The two-story building measures 27 x 30 feet and is embellished with two bands of a wave design along the upper portion of the exterior walls. The fixed metal sash windows in the restroom are shaped like portholes. The building also contains a partial basement that is used for storage. Changes to the building since the period of significance include



**Figure 58.** West Convenience Station View looking east (NPS 2010)





**Figure 59** East Convenience Station. View looking west. (NPS, 2007)

construction of a new concrete floor, addition of new kitchen equipment and a stainless steel counter, as well as the addition of an awning over the counter and serving windows in the concession stand. A stairway leading to the roof and observation deck wraps around the exterior of the building. The deck has built-in benches and a small unfinished shelter, designed to provide lookouts for lifeguards. The roof deck includes a metal rail parapet, similar to the metal parapet on the Bathhouse.

### East Convenience Station

The East Convenience Station is adjacent to the Rowing Club buildings at the end of Jefferson Street. The building was completed and opened to the public in 1944. The oval-shaped building has a white stucco exterior, similar to the West Convenience Station. Its principal design elements are stylistically consistent with the other buildings in the park with an elliptical form, banded wave designs, and a staircase that wraps around the exterior. (Figure 59) The roof of the building was also designed for use as a lifeguard station. Like the West Convenience Station, restroom fixtures have been removed and the building is currently used for storage.

### Sea Scout Building

While the army was using Aquatic Park (1941-1948), it constructed a small landing wharf at the west end of the cove near the West Convenience Station and the end of the Municipal Pier. The facility, including a concrete pier and small wood-frame building, was built between 1943 and 1944, and was later expanded and remodeled. It now serves as the Sea Scout Building. Constructed on pilings, access to the one-story, wood-frame building, is by narrow concrete stairs from Van Ness Avenue. (Figure 60) The building contains many small rooms used for storage, offices, and classrooms. It also features a docking and boat repair facility for the Sea Scout organization. The WPA plans for development of the park included a building in this location for rowing clubs, and a similar building to be used by the Sea Scouts and the Unified School District was planned for the east side of the cove; neither was built due to a lack of funding. The park intends to extend the use of this building to include more park activities and partner education classes in the near future, making this building the core of the Maritime Heritage Learning Center.

**Figure 60** Sea Scout building at the west end of the cove. View looking north (NPS, 2010)





## Seawall

During initial development of Aquatic Park, the WPA designed and constructed a seawall along the cove to reinforce and stabilize the shoreline prior to excavation and construction of the Bathhouse. Concrete foundations were prepared, and between 1931 and 1933, thousands of cobblestones were transported to the site in order to construct the seawall. As built, the wall gradually rises from seven to ten steps as it moves westward, maintaining a level elevation along the top of the structure, following the shoreline of the cove to the base of the Municipal Pier. The earlier rubble and concrete seawall haphazardly constructed in 1931 near the Municipal Pier was torn down, and the base of this structure was used as the foundation for the new wall<sup>10</sup> Today the seawall extends from the east end of the park near the East Convenience Station to meet the Municipal Pier. (Figure 61) Where it meets the Municipal Pier, the seawall is largely above grade.

## East and West Speaker Towers

In 1938 two reinforced concrete speaker towers were constructed on the east and west ends of Aquatic Park. Modern and sculptural in style, each tower sits on a granite pier with a graceful concrete support structure for the speaker housing, which sits 35 feet above the ground. The speaker housing is circular in plan and has a series of concentric horizontal bands

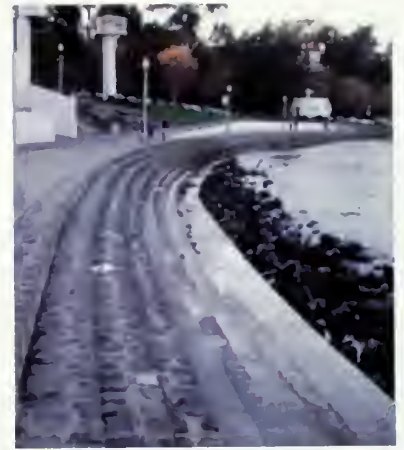

**Figure 61** One of the earliest structures built by the WPA, the Seawall wraps around the cove, creating a hard edge between the water and the Beach Promenade. View looking west. (NPS, 2007)

**Figure 62** West Speaker Tower View looking north. (NPS, 2007)

across the face. (Figure 62) A metal ladder providing access to the back of the speaker housing has been removed. The cover grille on the East Speaker Tower has also been removed (but will be repaired and replaced). Like other structures built by the WPA, the speaker towers were designed by William Mooser Jr. in the Streamlined Moderne style, and are integral structures in the designed landscape. Planting beds at the base of each tower historically incorporated plants that were maintained in a manner that reinforced the architectural character of the towers.

### Municipal Pier

Construction of the Municipal Pier began in 1931 and concluded in 1933. Built by the City of San Francisco, the pier was constructed on the site of the Army Quartermaster's Pier at the northwest corner of Fort Mason. The pier was designed for recreation, but it also incorporated an innovative baffle system that functioned to mitigate the effects of the bay currents on the cove. The pier included electrical power lines for lamps along the length of the structure, and water conveyance infrastructure for the convenience station, which was planned for the end of the pier. when completed, the San Francisco Board of Park Commissioners noted:

*... use of the Pier by bass fisherman has proven [so] popular [that] certain portions of the concrete structure were sealed in 'Konset,' a cement-finishing material, in order to keep it in a sanitary condition.<sup>11</sup>*

The baffles incorporated into the pier structure serve as a breakwater. Some riprap has been added over the years to act against scouring at the mud line. The pier is curvilinear in plan with a round, bulb-like end.



**Figure 63.** The Municipal Pier with Fort Mason Pier 4 in the foreground. View looking east. (NPS, 2007)

(**Figure 63**) The reinforced concrete and jacketed wood pilings support a concrete deck. Concrete curbs along the outer edges of the roadway serve both as a conduit for utility pipes and as a divider between vehicles and pedestrians. Concrete benches and streetlights are located at even intervals along the length of the pier. Most of the original streetlights function, but in some cases fixtures have been broken or removed and only the poles remain. The pier railing was designed to accommodate the placement of the concrete benches. Notches in the railing opposite the benches provide easier access for fishing and improve views to the water while seated.

During the military occupation of the park between 1942 and 1948, an Army tug crashed into the pier, causing severe structural damage. Repairs were made in 1947 and the pier was returned to the city in early 1948. The pier was also seriously damaged when it was rammed in a heavy fog by a freighter on February 3, 1953, and repairs to the structure were estimated to cost over \$10,000.<sup>12</sup>

Today the pier is in very poor condition due to saturation by seawater and deterioration of metal rebar. In 2008, the park installed a fenced gate at the entrance to the pier for safety reasons, and in 2009 most of the west (bay) side of the structure was also fenced to prevent access to the most deteriorated portion of the structure. The National Park Service is in the process of planning a major rehabilitation project to repair and stabilize the structure. (**Figure 64**)

The convenience station and lifesaving station at the end of the pier was less than 50 percent complete when the WPA turned the project over to the city. These structures remain unfinished today. The circular building was designed to match the other two convenience stations in Aquatic Park. Only the rough concrete exterior was constructed. Access to the unfinished building is by bolted hatches on the roof. The interior rooms are currently filled with rubble and water. (**Figure 65**)

## Retaining Walls

Two major structural walls on the west side of Aquatic Park date to the historic period of park development, and retain the grade on the southwest corner of the park. Based on historical documentation, the stone masonry retaining wall near the site of the former water pumping



**Figure 64** Fencing was added to the Municipal Pier in 2008 and 2009 to enhance safety until structural improvements can be completed. View looking north. (NPS, 2010)



**Figure 65** The unfinished convenience station at the end of the Municipal Pier (NPS, 2007)



**Figures 66.** Constructed in 1936, the stone masonry retaining wall located on the west end of the park, was a significant structure, stepping down from the highest point near Van Ness Avenue. View looking east. (Courtesy of the San Francisco History Center, San Francisco Public Library AAA 6725)



**Figures 67.** Stone masonry retaining wall as it appears today near the Bocce Ball Courts. A considerable amount of backfilled was used after the pumping station was removed to create a level grade on the south side of the structure. View looking west towards Van Ness Avenue. (NPS 2007)



station pre-dates most of the park construction by the WPA. The stone wall and much of the fill material used to construct this wall came from cemeteries located in the Richmond District and Laurel Hill sections of the city, when the graveyards were moved to Colma in the early part of the 20th century. The wall has concrete coping with granite piers and acorn finials on top. This wall was significantly altered during construction of Aquatic Park. The original wall was longer and the western end had a curve. The eastern end was also either angled or curved. Today, with the

exception of a single acorn finial, the east section of the wall is largely buried and the west side, including the curved portion of the wall, was removed at an unknown date. (Figures 66, 67)

The other retaining wall, which runs parallel to the east side of Van Ness Avenue, meets the west end of the stone masonry wall at a 90-degree angle. A 1938 WPA construction photograph shows the concrete retaining wall abutting the stone masonry retaining wall across from the sidewalk on the east side of Van Ness Avenue. The stone masonry wall and concrete retaining wall, along with the change in grade, serve to separate the pedestrian walkways from the lawn areas and the Bocce Ball Courts below.

#### *Promenade Retaining Wall*

This retaining wall begins at the separation between the Beach Promenade and the State Belt Railroad and curves around to the north side of the West Convenience Station, enclosing a small lawn area. The retaining wall is 19 inches wide, highest at its center, and tapers lower at its ends. The wall appears in a March 18, 1938 historic photograph of the park and is shown on John Punnett's 1938 park plan.

#### *Concrete Retaining Wall*

At an unknown date after the period of significance, a concrete retaining wall was built parallel to the State Belt Railroad tracks, adjacent to the stair along the West Bleacher stairs. This wall post-dates the period of significance and is a non-contributing structure.

### **Summary**

With few modifications, the buildings and structures in Aquatic Park retain their historic design and architectural integrity and contribute to the historic designed landscape of Aquatic Park. Contributing buildings include the Bathhouse, the East Convenience Station, the West Convenience Station, and the Sea Scout building. Contributing structures include the West Speaker Tower, the East Speaker Tower, the Seawall, Municipal Pier, two retaining walls, the East Bleachers and the West Bleachers.

## Circulation

Historically, pedestrian circulation in Aquatic Park was designed and integrated with the sloping topography and graded terraces around the Bathhouse, providing movement through the park landscape. Walkways and roads were curvilinear in design, wrapping around buildings and through lawn areas with transitions between grades and functional areas of the park. The seawall with the Beach Promenade was designed to follow the shoreline around the cove, creating a structural edge and flexible pedestrian area used for a variety of activities. In a similar manner, the extension of Van Ness Avenue was originally designed as a promenade, 15 feet wide with an allée of street trees.

Today park visitors approach the park from the west using either McDowell Street through Fort Mason or Van Ness Avenue. To the south and east, the park is approached from Jefferson, Polk, Hyde, and Beach streets. Remaining circulation in Aquatic Park consists of several components dating from the period of significance, including the State Belt Railroad tracks, the Municipal Pier, the Van Ness Avenue extension, the Beach Promenade, vehicle ramps, and pedestrian walkways and stairs. Virtually all of these features were originally designed and located in the site plan for Aquatic Park developed by civil engineer John Punnett in 1938. They and are described in more detail in the following sections.

### Beach Promenade

The Beach Promenade is paved with concrete and has a uniform width of approximately 15 feet. In the early site plans for Aquatic Park, city engineer John Punnett used the term “promenade” for the walk along the water, suggesting that this primary pedestrian route was designed to be somewhat grand. The Beach Promenade begins at the east end of the seawall, adjacent to the East Convenience Station, and continues west along the cove to Van Ness Avenue. It provides access to the beach, the convenience stations, the bleachers, the Bathhouse, Van Ness Avenue, and the Municipal Pier. The Beach Promenade connects Jefferson Street on the east with Van Ness Avenue on the west, paved walkways near the east and west bleachers, and the two concrete ramps that curve around the Bathhouse. (Figure 68)

**Figure 68.** Beach Promenade in front of the Bathhouse, view looking west. (NPS, 2007)





## State Belt Railroad Tracks

The initial design for Aquatic Park incorporated the alignment of both the State Belt Railroad tracks and the Municipal Pier into the overall circulation system. The State Belt Railroad was originally constructed as a single standard-gauge track on a trestle over the lagoon in 1914. These tracks were relocated (in 1925 and again in 1936) and incorporated into the Beach Promenade during development of the park. The State Belt Railroad of California was renamed the San Francisco Belt Railroad (ca. 1969). Crossing Aquatic Park from east to west, the trains ran infrequently and generally at night. The tracks historically extended from the Embarcadero through the Fort Mason tunnel, eventually reaching lower Fort Mason and on to the Presidio. Within Aquatic Park, the portion of track between the stairs west of the West Bleachers and Van Ness Avenue appears to have been paved in the late 1970s when the railroad was no longer used. Over the years, the area between the rails has been backfilled with asphalt to reduce hazards for pedestrians and bicyclists. In spite of these changes the tracks remain in the same location as they were during the period of significance.<sup>13</sup> (Figure 69)



**Figure 69** Asphalt walkway located between the Beach Promenade and the slope up to the Upper Promenade with the tracks at grade. (NPS, 2007)

## Sidewalks

Concrete sidewalks are located on the east and west sides of Van Ness Avenue, and along the north side of Beach Street bordering the park. These serve to provide access to the park and connect the park to adjacent areas. Green terrazzo paving at the entrance to the Bathhouse was restored in 1984.<sup>14</sup> The aquatic-inspired wave design in the paving is composed of different shades of green and complements the building's slate entrance façade. (Figure 70) Currently, a gangway-styled ramp on the sidewalk provides universal access from Beach Street to the Bathhouse lobby. Historic photographs indicate the original sidewalk did not extend west past the terrazzo paving. Both the Beach Street and Van Ness Avenue sidewalks were completed by 1938. The overall design of the sidewalk, including the alignment and width, remain from the period of significance even though alterations appear to have occurred over time, such as cutouts for street trees in the sidewalk along Van Ness Avenue. Generally sidewalks are in fair condition with areas of slumping, jacking, cracking, and asphalt patchwork.

**Figure 70** Terrazzo paving in front of the Bathhouse. View looking west (NPS, 2007)





**Figure 71.** View of three components of the pedestrian circulation system in Aquatic Park. The Beach Promenade along the shoreline, the State Belt Railroad tracks (asphalt), and a portion of the Upper Promenade as it passes the West Speaker Tower. (NPS, 2008)

## Walkway System

In addition to the Beach Promenade other paved walkways remain in the park from the period of significance. Virtually all of these individual walkways are paved with asphalt and are components of the historic design of the overall pedestrian circulation system in Aquatic Park.

The first contributing portion of this system is the Upper Promenade, an asphalt-paved walk approximately 10 feet wide, extending from Van Ness Avenue past the West Speaker Tower. Off of this alignment, a stairway comprised of 19 concrete steps, 12 feet wide with a central round metal railing, connects pedestrians with the Beach Promenade. From the top of these steps, the Upper Promenade continues to the west end of the Bathhouse, where it meets the Beach Street sidewalk. (Figure 71)



**Figure 72.** View of the East Speaker Tower and walkways looking northwest from edge of Victorian Park. (NPS, 2007)

The second contributing section of pedestrian walkways begins on the east side of the Bathhouse, at the intersection of the east vehicle ramp and the Beach Street sidewalk. From this intersection, the walkway extends diagonally toward the East Speaker Tower. Midway along this walkway, a short spur provides a connection to the center of the East Bleachers. The walkway forks at the East Speaker Tower, with one walk leading to the east end of the bleachers and the other section continuing into Victorian Park. A third section of this walkway spurs south to connect with the Beach Street sidewalk. (Figure 72)



**Figure 73** The extension of Van Ness Avenue in 1936 historically linked the city with the Municipal Pier and created a defining edge to the new park. (NPS, 2007)

### Van Ness Avenue Extension

Very early in the development of Aquatic Park, the City of San Francisco extended Van Ness Avenue as it formed the west boundary of the park, northward along the base of the Black Point. This extension was designed over extensive fill in order to provide access to a new recreational pier proposed for Aquatic Park. To meet the pier, Van Ness Avenue was extended approximately 150 feet north along the base of the point. Prior to extending Van Ness Avenue, several rowing clubs located on the western shore of the cove were relocated to the east side of the water. Sidewalks were added to both sides of Van Ness Avenue to allowed pedestrian access to the Municipal Pier, while the road itself provided access and parking for automobiles. This area continues to function as originally designed. (Figure 73)

Other circulation features constructed after the period of significance are located along the west side of Van Ness Avenue, around the Bocce Ball Courts, the east edge of the East Bleachers and in Victorian Park. None of these additions alters the original design and framework for circulation in Aquatic Park. These additions include two brick sidewalks in the area west of Van Ness Avenue (“pocket park”) that were added in 1975, and an asphalt sidewalk to the bocce ball area that was added in the 1960s after the overhead structure was constructed. The remaining changes to circulation within the historic district all occurred in Victorian Park beginning in 1956 with the cable car turnaround (tracks and turntable).



In 1962, during construction of Victorian Park, a pedestrian plaza was built connecting the cable car turnaround to Aquatic Park. This plaza was paved with decomposed granite, and rows of basalt block pavers lined the edges of the plaza. The area around the cable car turnaround was paved and a band of basalt block pavers was added around the outer edge, and pathways were designed to connect with Aquatic Park, Jefferson Street, and Hyde Street sidewalks. Finally, a series of steps and concrete landings were added from the north side of the cable car landing to provide a direct connection to the north side of the park.

In 1982 the orientation of the entrance of the cable car line at Victorian Park was altered. Originally the line entered the park on the east side from Hyde Street at a 90-degree angle (the tracks were parallel to Beach Street). After renovations, the tracks entered the park at the southeast corner at roughly a 45-degree angle. In addition, a path that originally followed the slope around the cable car platform was moved farther north to accommodate the newly extended fill slope designed for the realigned turnaround. During this renovation, the east side of the plaza was extended and a new seating area created. This area was covered with interlocking brick pavers. A new set of concrete steps lead to the sidewalk along Hyde Street. Sometime after 1982 the Victorian Park paths and plaza were paved with asphalt.

### Summary

Although there are several non-historic additions to the circulation system adjacent to Aquatic Park, virtually all of the original designed walkways within the park remain with integrity. The walkway past the East Speaker Tower appears to be the only place within the park where the historic alignment and location of the walkway differs from the original 1938 plan by John Punnett. Today, this is aligned in a less attenuated “Y” configuration than depicted in Punnett’s site plan. The Punnett design for this area included a narrow junction of the two pathways at the base of the speaker tower; the two arms of the “Y” followed independent, serpentine paths: toward the Beach Promenade in one direction, and the Beach Street sidewalk in the other. It is likely that this section of walkway was realigned and reconfigured during development of Victorian Park. East of the speaker tower the walkway widens, and asphalt paving replaces the turf cover originally identified on the Punnett site plan.

In spite of this change the overall design of circulation in Aquatic Park, including the location, alignment, and character of the primary and secondary walkways, the promenade, ramps, and stepped transitions designed by John Punnett and implemented by the WPA, remain today and contribute to the historic designed landscape of Aquatic Park.

## Vegetation

### Historic Character

Although the City of San Francisco Park Commission developed a planting plan for Aquatic Park in 1937, the WPA installed few plant materials during development and construction. Based on drawings, plans, and historic photographs of the park during and after the period of significance, it is evident that plant materials installed in Aquatic Park were added over several years and did not follow any single plan. As a result, specific plant materials used throughout the park probably changed more than once during the period of significance.<sup>15</sup>

The 1937 city plan for the park incorporated many planting concepts from John Punnett's 1937 Landscape Plan, including the concepts of locating planting beds near building foundations; at grade changes; and where pedestrian walkways intersected. During the period of significance, large areas of lawn and a limited palette of shrubs that complimented the Streamlined Moderne style of the buildings characterized the landscaped grounds of Aquatic Park. Plants were used in two characteristic ways during the period of significance: as mass plantings of a single species (low growing) or as groupings to create a hedge along the foundation of a building or structure.

#### *Vegetation around the Bathhouse*

The formal entry to the Bathhouse along Beach Street historically included two planting beds along the foundation of the building, on either side of the doorway. These beds, installed by 1938 (and removed after 1952), were planted with small trees, shrubs, and perennials. Based on historic photographs, the configuration, species, and even the pruning style changed at least once during the period of significance. Today, these beds are paved over with asphalt. (Figure 74)



**Figure 74** Plantings were established on both sides of the Bathhouse entrance, adding a degree of formality to the front facade of the building, ca. 1940. (*San Francisco Maritime NHP, Historic Documents, Photograph Collection P81-073.2n*)

North of the Bathhouse, two oblong planting beds with a curb edge were initially planted in turf with a shrub border. These shallow planting beds remain today although the plant materials have changed over time. Today large metal anchors are located in the unplanted beds.

In 1941, also on the north side of the Bathhouse, 10 columnar junipers were planted in shallow planters located in front of each vertical wall element along the lower façade of the Bathhouse. Today only the six junipers (*Juniperus sp.*) in the center six beds remain in fair condition; the other planters are paved over.

#### *Plantings between Van Ness Avenue and the Bathhouse*

Historic photographs indicate that in 1940, the long, narrow triangular planting bed in front and south of the Sea Scout building was planted with a small shrub species or beach grass. By 1941 this area contained a row of low-growing shrubs planted adjacent to the Beach Promenade connecting with Van Ness Avenue.<sup>16</sup> The landscape in this area was modified in 1943 when the Sea Scout building was constructed and a small walkway, constructed to provide access to the Sea Scout building from Van Ness Avenue, divided the planting bed into two separate beds. The remaining section of grass extending north was paved over. South of the walkway leading to the Sea Scout building, the bed was planted with grass. This area remains in turf grass today. By 1946 the shrubs along the eastern edge of the Beach Promenade were gone. Aerial photos from 1948 also show what appear to be trees in the area north of the Sea Scout Building.



Planting beds are also located around the base of the West Convenience Station. The planting bed on the west side of the structure immediately left of the snack bar window has a concrete curb edge, painted white, and was originally planted with an unidentified low-growing shrub. Another planting bed on the north side of the building, adjacent to the entrance to the men's room, was planted with a shrub hedge in 1941. Historic photographs indicate that the rest of the bed had either grass or a low ground cover. Today, this bed is planted with mirror plants (*Coprosma repens*). The third and largest planting bed around the West Convenience Station is located on the east side of the building by the entrance to the women's room and extends southeast. In 1939 the sloping bed was planted with low shrubs. By 1941 the southern portion of the bed was planted with either groundcover or seasonal flowers, and is now grass. (Figure 75)

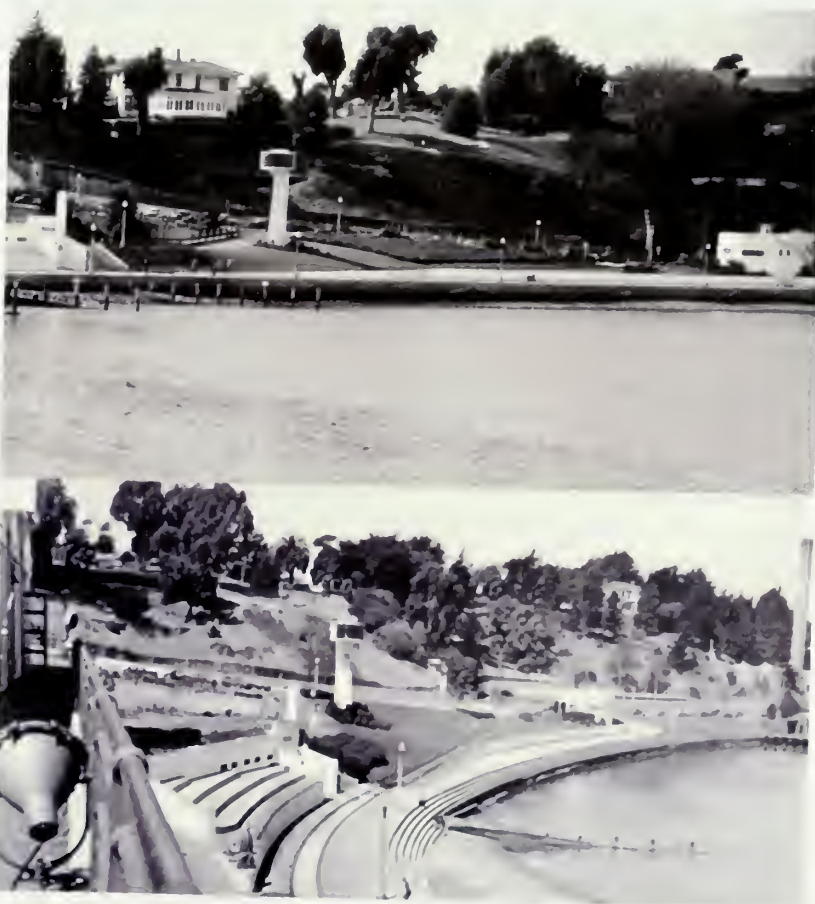

**Figure 75** Top: Planting patterns and landscape details west of the Bathhouse, ca. 1939. Note the large planting bed with low-growing vegetation massed between the West Speaker Tower and the West Convenience Station (*San Francisco Maritime NHP, Historic Documents, Photograph Collection, A12, 17, 505n*)

Bottom: Similar view, 1946. The large planting area is significantly reduced, with beds left at the intersections of walkways and around the foundations of structures. Open lawn has replaced the planting bed on the slope between the West Speaker Tower and the tracks. (Courtesy of the *San Francisco History Center, San Francisco Public Library AAA 6697*)



**Figure 76.** Grecian laurels (*Laurus nobilis*) remaining around the West Speaker Tower. View looking west. (NPS, 2008)



**Figure 77.** *Escallonia* hedge on the north side of the masonry wall along the Upper Promenade. (NPS, 2008)

The fourth small planting area is located on the south side of the building. Historic stone curb edges both sides of the walkway. During the historic period, this bed appears to have been planted with similar materials as the larger planting bed, adjacent to the path leading into the restroom. A Monterey cypress (*Cupressus macrocarpa*) was removed from this area in 2001 due to the damage to the building from the tree roots, and the potential hazard the tree had become to visitors.<sup>17</sup>

In 1939 a large portion of the slope south of the West Convenience Station was planted with what appears to be a massing of low-growing shrubs (about 3 feet tall). This planting remained in place through the period of significance. By 1946 turf grass replaced most of the shrub mass. None of the shrubs from the area remains today.

Between 1939 and 1941, Grecian laurels (*Laurus nobilis*) were planted around the foundation of the West Speaker Tower and were pruned to form vase-shape shrubs. This planting bed, surrounded by grass, extended down slope about 24 feet, narrowing to a point. After the military occupation of the park, the laurel shrubs were allowed to grow into more of a free-form tree shape. In 2000 NPS maintenance staff cut the laurel back to stumps in an effort to reduce their size and restore their form as shrubs. Today, the laurels are returning to a shrub form and are maintained in the original bed along with a dwarf variety of *Escallonia* around the laurels. (Figure 76)

The grass area continued east of the speaker tower and ended in a shrub bed adjacent to the stairs leading down to the Beach Promenade. Originally, the shrub bed was over 40 feet long and at least 18 feet wide. A narrow strip of grass (about 4 feet) below this shrub bed connected the lawn area to the base of the west staircase. Today the grass has been replaced with paving and a concrete retaining wall (non-historic) approximately 18 inches high. At the center of this planted area, lavender cotton (*Santolina chamaecyparissus*) and ox-eye daisy have replaced the shrubs. The lavender cotton was, until recently, pruned to spell the words “Aquatic Park.”

Immediately south of this area, a hedge of *Escallonia* follows the path along the entire length of the masonry wall. It is not clear that there was a hedge in this location during the period of significance. The hedge does appear in a photograph from the late 1940s. (Figure 77)



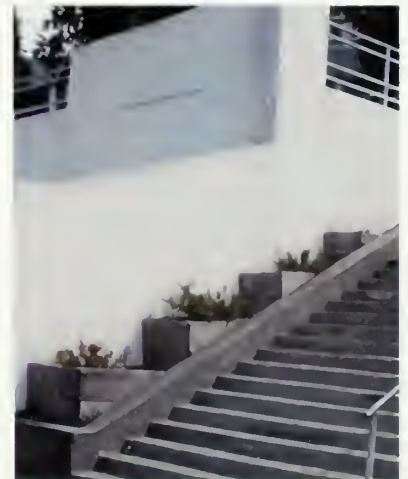

**Figure 78** Area northeast of the Bocce Ball Courts prior to the bleacher rehabilitation project. This area was used as a staging area during construction and was significantly altered in 2009. (NPS, 2007)

East of the Bocce Ball Courts, the open grass area was originally used as an unpaved parking lot for Aquatic Park. John Punnett's 1938 site plan specified a shrub and tree border surrounding an open lawn on the south and west, creating a boundary between Aquatic Park, a proposed playground, and Beach Street. A single Acacia tree is depicted on a 1952 plan of the park and is visible in an aerial photograph. Today, a planting bed defines the north side of the Bocce Ball Courts; a similar bed on the east side was removed in 2008. These beds contained a mixture of small shrubs, perennials, blackberry, and ivy. A plum tree is planted in the west end of the bed along the north side. Three *Pittosporum sp.* (tree form) are located along the west side of the Bocce Ball Court area (next to the concrete retaining wall). A row of seven English laurel are located in the raised bed in the southwest corner of the Bocce Ball Court area. The area immediately south of the acorn retaining wall was covered with sand until the early 1980s, when it was planted with grass. (Figure 78)

Low-growing shrubs were historically planted in the bed between the West Bleachers and the stairs. (Figure 79) This bed was replanted as part of the bleacher rehabilitation project. Above the women's shower room, low-growing shrubs were planted to surround and screen the two skylights. Low-growing shrubs were also planted along the south façade of the bleachers, and in the turf area above the West Bleachers.

**Figure 79** The narrow, stepped planting area between West Bleachers and the stairs was redeveloped as part of the bleacher rehabilitation project (NPS, 2010)





### *East of the Bathhouse*

A 1938 photograph shows a hedge, approximately 4-feet high planted along the wing wall of the east bleachers. This wall is perpendicular to the Beach Street sidewalk and defines the edge of the east vehicle ramp leading to the Beach Promenade. By 1939 this hedge extended along the south side of the east bleacher wall. For unknown reasons, the hedges were removed sometime after 1949. The three large skylights above the East Bleachers were originally enclosed by boxwood hedges, but these were removed and the grass was allowed to die to prevent more water leaking into the structure below.<sup>18</sup>

South of the walkway that borders the large skylights are three smaller skylights, which were also enclosed by hedges. These are located in the large triangular grass area along Beach Street. The hedges around these skylights were in place until at least 1952, lasting longer than those along the bleacher wall. The grass area remains; however, a new planting bed was added along the east edge of the grass when construction on the west side of Victorian Park extended into Aquatic Park. Although compatible, this change altered the original design for this area.

North of this area a Monterey pine (*Pinus radiata*) was located (near the center pedestrian walkway), but was removed during the 2008-2009 bleacher rehabilitation project.

In 1939 a small planting bed around the East Speaker Tower was planted with Grecian laurel (*Laurus nobilis*), similar to the planting around the West Speaker Tower. A 1952 photograph shows these plants were still being maintained as shrubs. Over the years, however, the laurel shrubs grew into trees, and in 2000 the plants were pruned to encourage stump sprouting and restore a shrub form.

North of the East Speaker Tower, a row of deciduous shrubs was planted along the foundation at the southeastern corner of the East Bleachers. These shrubs appear to have been planted by 1946. Up until the bleacher rehabilitation project, this planting bed was terraced with wood retaining walls stepping down the slope. The historic plantings were replaced more recently with a variety of plants, including *Pieris*, azaleas (*Rhododendron sp.*), *Abutilon*, and perennials such as Japanese anemones (*Anemone japonica*), none of which were planted during the period of significance. All of these materials were moved as part of the bleacher rehabilitation project.

Aerial photographs suggest that some type of low-growing shrubs may have been planted around the East Convenience Station. Currently there are two large metal boat propellers located in the former planting beds and no planting.

## Van Ness Avenue

As depicted in early plans for Aquatic Park, London plane trees (*Platanus acerifolia*) were planted along both sides of Van Ness Avenue extending along the road out to the Municipal Pier, creating a canopied allée along the street. The east side of the street was planted in the late 1940s or early 1950s. Additional trees were planted on the upper portion of the west side of the street by the mid-1950s and along the lower portion by the mid-1960s.<sup>19</sup>

### *West side of Van Ness Avenue (Pocket Park)*

During the historic period, the west side of Van Ness Avenue was part of Fort Mason and was used as a storage area. Sometime between 1958 and 1969, the area between the sidewalk on the west side of Van Ness Avenue and the Fort Mason retaining wall was planted with grass. In the mid-1970s, John B. Sage, a landscape architect in the National Park Service, Western Regional Office, prepared a new design for the area. The new design called for grass to be used throughout the area. (Figure 80) Four earthen berms in the lawn, approximately 3-4 feet tall, were included in the plan; these berms created an informal arc in the middle of the grass area extending down toward the city pumping station.

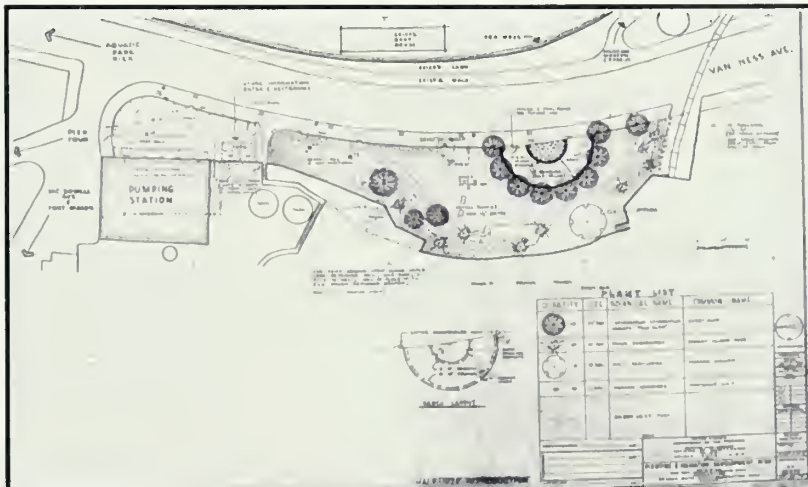

**Figure 80** A copy of the 1975 landscape plan for Pocket Park on the west side of Van Ness Avenue (NPS, Technical Information Center, Denver )



**Figure 81.** View looking north into Pocket Park along Van Ness Avenue, prior to removal of the benches and paving materials from the 1975 design. (NPS, 2007)

Plant species identified in the plan include 12 sweet gums trees (*Liquidambar styraciflua* 'Palo Alto'), nine Canary Island pines (*Pinus canariensis*), and at least one weeping willow tree (*Salix babylonica*). A semi-circular brick paved area with benches around the perimeter of the paving was also proposed, with eight sweet gum trees in a semi-circle on the west side of the brick plaza. The interior of this area was planted with fortnight lily (*Moraea iridiodes*). This 1975-76 design extended from the railroad tracks (at the tunnel) to the path leading up the stairs to Fort Mason. A planting bed was added along the base of the east wall of the Pumping Station No. 2 at this time. (Figure 81)

Today this design is only marginally intact. Many of the trees planted as part of this design are gone. Benches have been removed from the small paved area and plants have been removed from the bed around the paving. Several of the Canary Island pines (*Pinus canariensis*) remain and are planted in small groups and surrounded by lawn. Two fig trees (*Ficus sp.*) are located next to the outer edge of the Van Ness Avenue sidewalk. Their location and growth habit has a negative impact on the allée of London plane trees that line Van Ness Avenue. There is no evidence to suggest the fig trees were planted during the period of significance.

## Summary

Historically the framework for establishing ornamental plantings in Aquatic Park was, to a large measure, based on John Punnett's original design. Implemented and modified over several years, only a few of the plant materials in the park today date to the period of significance. In spite of this, the general location, scale, and character of planted areas in Aquatic Park still provides a setting similar to one that existed during the period of significance. The locations of the planting beds defined by circulation paths, buildings, topography, and retaining walls remain as part of the original layout of the grounds. In this regard, few individual plants are considered historic; however, the open lawns and the general location, scale, and character massing of plant materials in articulated planting beds remaining in Aquatic Park does reflect the historic character of the original design.<sup>20</sup>



## Endnotes

### Analysis and Evaluation

1 A summary statement of significance and integrity for the historic designed landscape with an associated table of contributing and non-contributing resources can be found in Appendix B.

2 See Sanborn Map Company's Insurance Maps of San Francisco, California, Volume One (New York, Sanborn Perris Map Company, 1899).

3 See Toogood: p.122.

4 See John Punnett, "Plan of Proposed Aquatic Park"(1913).

5 See Dow: p. 68.

6 See Bush: p. 133.

7 See "A Palace for the Public." WPA Fact Sheet (1939).

8 There was no original exterior door into this space. The street entrance was added, perhaps as late as 1963, but more likely in the early 1950s.

9 WPA Press release, 1939.

10 See Delgado: p. 3.

11 See San Francisco City Board of Park Commissioners, Meeting Minutes (July 19, 1934): p. 49.

12 See Delgado: p. 93.

13 City and NPS planning documents from the 1970s and 1980s recommended preserving the tracks for a proposed Municipal Railroad extension through the tunnel. During early planning phases of the proposed F Line Extension project the promenade route was dismissed as a potential based on the increased usage of the promenade by bicyclists and pedestrians.

14 According to park records, this work was accomplished by the same firm that had done the original work at Aquatic Park, and perhaps more remarkable, the work crew was lead by the son of the person who did the original terrazzo work at the park.

15 There are gaps in the photo documentation, making it difficult to ascertain a point at which the park plantings were "complete." In addition to the historic photographs, several drawings and plans were used to identify plant materials and characterize vegetation during the period of significance. The primary plans with information about plantings from the 1920-1945 period of significance include several drawings of John M. Punnett, including his 1936 plan, his 1937 "Landscape Plan" for the core area of the park, and his 1938 plan prepared after the WPA started work. In addition, photographs of a model built circa 1935 for the entire Aquatic Park area provide additional clues about how the plantings and overall layout of the grounds were envisioned. Since the extent to which these plans were implemented is not known, these landscape plans only offer ideas of the proposed historic character and patterns, not precise layouts.

16 Detail in the photograph is limited but shows an area next to the beach promenade that is light in color, indicating that the ground was either bare, or planted in a low-growing material like grass.

17 In order to determine the age of the tree, park staff counted the tree rings, and dated the tree to 1970. (Conversation with park historian Ted Miles, SAFR, 2001).

18 The hedges and general plantings are part of the bleacher rehabilitation project.

19 Based on observations and the relatively small size of these trees today, some question if the existing London plane trees along Van Ness date to the 1950s and 1960s, or may have been planted later as replacements or additions.

20 Exceptions include the Grecian laurels around the east and west speaker towers, the *Ecallonia* hedge, and the Monterey cypress south of the east bleachers.

# TREATMENT

## Introduction

Recommendations for treatment of the historic designed landscape of Aquatic Park are predicated on direction provided in the park *General Management Plan, Environmental Impact Statement, San Francisco Maritime National Historical Park, 1996* (GMP) and on the evaluation of cultural landscape characteristics and features that contribute to the significance of the historic district. Preservation is the primary treatment applied to the park landscape. As a National Historic Landmark, Aquatic Park represents both an important period of public works construction in the United States, and is an exceptional example of architecture and landscape architecture styles significant in the nation's history. Preservation of individual features that contribute to the significance of the designed landscape is critical for retaining the physical attributes, design integrity, and historic character of Aquatic Park. In addition to preserving historic features, it is also essential to preserve the landscape patterns and relationships that characterize the design such as the spatial relationship between the buildings and the landscape, the alignment and materials comprising circulation systems, the pattern and character of ornamental vegetation, and the aesthetic of the designed landscape holistically. Rehabilitation of the historic designed landscape is a secondary preservation treatment allowing compatible adaptive use of the grounds to accommodate contemporary visitor activities, interpretation, sustainable maintenance practices, and NPS operations and administration. Rehabilitation especially applies to adaptive use of the historic grounds within the context of the larger urban setting, and the potential adaptive use of historic structures or the modification of buildings and grounds to meet health/safety issues and accessibility. Finally, in some cases, restoration is a recommended treatment when reestablishment of non-extant historic features enhances visitor understanding of the historic designed landscape and is critical to maintaining the cohesive character of the historic district within San Francisco Maritime National Historical Park.

Recommendations in this report may be aggregated to provide the basis for a comprehensive and integrated landscape rehabilitation project



for Aquatic Park. Like many urban parks, Aquatic Park absorbs an extraordinary amount of public use and has a number of operational issues that affect current use and the condition of the park grounds. Although individual recommendations made in this report support current planning and daily maintenance activities, overall preservation of the historic designed landscape is perhaps best served by a systematic program of rehabilitation for the historic designed landscape holistically, and the development of a preservation maintenance program for the grounds. As a National Historic Landmark District, the designed structures and grounds comprising Aquatic Park merit a high level of stewardship assuring the preservation of the attributes and resources that define this remarkable property for generations.

## Historic Design Character

The focus of treatment for Aquatic Park is preservation and rehabilitation of the historic designed landscape as planned and implemented during the period of significance—between 1920 and 1945. Although the site plan for the park went through several revisions over these years, the majority of the design was implemented and constructed over a relatively brief and concentrated period between 1936 and 1938 by the Works Progress Administration (WPA). The historic design character of Aquatic Park is defined by the combination of buildings and structures designed by William Mooser Jr. in the Streamlined Moderne style; the site plan developed by John M. Punnett that established the overall layout of the park including grading and circulation; and a planting plan that evolved over several years. In this regard, historic design character of the park is not expressed by one feature in isolation, but the relationship among the unique and stylized structures, engineered spaces, circulation systems, plantings, and a highly manicured appearance that defined the Streamlined Moderne style of the park. (Figure 82)

In many ways, the concentrated period of construction by the WPA strengthened park design by ensuring a physical and stylistic integration between the structures and grounds in relationship to the shoreline. Although this integration was purposeful and responsive to the tenets of the style and use of the park by the public, the site itself required a significant amount of modification to accomplish the design intent. Beginning as early as 1920, the landscape wrapping around the cove was re-graded, creating the series of narrow engineered terraces stepping back from the shoreline. Large amounts of fill material were brought in



to shape the shoreline and create the terraces, which were articulated by a framework of walls, steps, sloping walkways, and other structures. The result was a system of level spaces and transitions that accommodated the siting of buildings, provided open space for recreation, and linked activity areas with a system of pedestrian walkways.

Following John Punnett's plan, the circulation system followed the landforms using a hierarchy of walkways routing park visitors along the cove, around the Bathhouse and out to the Municipal Pier. Primary walkways, including the promenade along the Seawall and the Van Ness Avenue extension to the Municipal Pier, were designed as pedestrian strolling avenues, fifteen feet wide and surfaced with concrete. Narrower walkways formed the connecting routes between the upper terraces along Beach Street down to the Seawall along the shoreline, incorporating steps as necessary. These walks were aligned in a manner that was functional while emphasizing the horizontal lines and curvilinear forms, mirroring the architectural characteristics of the new park buildings.

**Figure 82.** Characteristic of the Streamlined Moderne style, an emphasis on clean lines required maintenance of clipped hedges, trimmed lawn, and edging along the walkways. View looking east from the Bathhouse, 1953 (*San Francisco Maritime NHP, Historic Documents, Photograph Collection, A12.17,547 1*)

**Figure 83.** A 1946 view to the westside of Aquatic Park showing the hierarchy of circulation, unique structures, planting beds and manicured landscape that characterized the Streamlined Moderne style. (Courtesy of the San Francisco History Center, San Francisco Public Library AAA 6697)



As documented in Part 1 of this report, plantings specified in Punnett's 1937 site plan for Aquatic Park were not installed during construction by the WPA. Based on historic photographs, the majority of planting in the park were installed incrementally over several years. During the period of significance, photographs indicate that vegetation in Aquatic Park was characterized by large areas of open lawn, shrub massed in planting beds located at the edges of buildings and where walkway intersected. Hedges were used to define the foundations of some structures and soften the face of retaining walls. Trees were used sparingly and strategically to effect transitions and strengthen the modern aesthetic. This relatively simple planting form and restrained plant palette was effective and complimented the Streamlined Moderne architecture of the park buildings, creating the distinctive form and modern lines of the designed grounds. (Figure 83)

Finally, as noted above, a key component contributing to the historic character of Aquatic Park is the maintenance of a highly manicured landscape appearance throughout the park. Clipped hedges and healthy plants, irrigated and mown lawns, edged walkways, smooth paved surfaces, stabilized structures in good repair, and clean building exteriors are important attributes of this designed landscape. While it is the aggregate composition of individual features that contributes to the historical significance of the park, it is the level of landscape maintenance that reflects the significant design style and conveys a sense of time and place to the visitor.



## Documentation for Treatment

In the absence of as-built plans that illustrate definitive components of the landscape design, other historic sources were used to determine appropriate treatment. In addition to the evaluation of cultural landscape characteristics, three historic reference materials provided the basis for decisions about treatment:

- Historic site plans developed during construction of Aquatic Park
- Aerial photographs taken near the end of the period of significance
- Historic photographs taken during and after the period of significance

Although helpful for understanding the patterns and relationships defining the landscape character of Aquatic Park, the available historical record was not always adequate to reveal every detail in the landscape. This was particularly true when trying to identify specific plant materials installed during the historic period. Because a consolidated planting plan was not located during the research phase of this report, the identification of specific plant materials from the period of significance is difficult or impossible to determine. Therefore, in cases where restoration of historic vegetation is determined critical to composition of the historic design or if it enhances visitor experience, recommendations for plant materials are based on the character of vegetation depicted in historic photographs—meaning plants that reflect the size, shape, texture, and form of the plants depicted in historic photographs. Whenever possible, selection of plant materials for the Core Area is also based on park operations and objectives for maintenance including visitor safety, views and vistas, and sustainability related to the current [2009] allocation of resources required to maintain the landscaped grounds.

A note is warranted about the documentation of historic vegetation and the character of plant materials as they mature and change over time. As discussed above, the basis for restoration of non-extant historic features is accurate historical documentation and detailed information about the individual feature during the period of significance. Although the period of significance for Aquatic Park extends over twenty-five years, most of the plant materials in the park were added towards the end of

the historic period, and plants that were in place by 1945 did not mature until well after the period of significance. For instance, the London plane trees (*Platanus acerifolia*) along Van Ness Avenue were young saplings during the historic period. It was not until many years later they attained their mature form, creating the canopied tree-lined avenue. This was also the case with some of the shrubs in the park, such as the Grecian laurels (*Laurus nobilis*) around the speaker towers. Judgments regarding intended character are often difficult to make, but certain reasonable assumptions can be made based on the characteristics and principles of the design style, the mature forms of the plants, and historical evidence of how the plants were maintained in the years following the historic period.

## Cultural Landscape Management Zones

Recommendations for treatment of the Aquatic Park landscape are organized into three *cultural landscape management zones* based on significance and integrity, historic character, and contemporary maintenance or operational issues. (Figure 84) The three cultural landscape management zones are the Core Area including Van Ness Avenue; Victorian Park; and the Bocce Ball Court Area. The Core Area is the heart of the historic district and contains all the resources that contribute to the designed historic landscape. Most of the recommendations in this report focus on this area. Both the Bocce Ball Court area and Victorian Park were primarily developed after the period of significance and while they are within the CLR study boundary, they do not contribute to the historic designed landscape. Treatment recommendations for these areas focus on compatible design in the context of public use and development adjacent to the NHL district. Within each management zone, recommendations include a brief overview of issues followed by general and specific recommendations for buildings and structures, circulation, and vegetation.

All treatment recommendations documented in the Cultural Landscape Report for Aquatic Park are made in compliance with current park planning and management documents, and NPS policies and standards including *The Secretary of the Interior's Standards for the Treatment of Historic Properties, with Guidelines for the Treatment of Cultural Landscapes*. For some recommendations in this report, and prior to implementation, the park may need to undertake additional compliance and/or consultation with cultural resources technical staff.

## Figure 84 Cultural Landscape Management Zones

### Cultural Landscape Report: Aquatic Park

San Francisco Maritime  
National Historical Park  
2010







# Treatment Plan (Schematic)

Figure 85

## Sources

1948 Aerial Photograph Aquatic Park; Historic Documents, Photograph Collection, San Francisco Maritime National Historical Park; Google Earth; Field Documentation 2005-2009; 2005 Aerial Photograph, Aquatic Park, Pacific Aerial Survey

## Notes

Symbols depicting materials and locations for plant materials are schematic. Placement and general concepts are presented as a way to amplify and illustrate written recommendations in the *Cultural Landscape Report, Aquatic Park*.



Cultural Landscape Report:  
Aquatic Park

San Francisco Maritime  
National Historical Park  
2010

National Park Service  
Pacific West Region  
Cultural Landscape Program



# Treatment Plan (Schematic)

Figure 85

## Sources

1948 Aerial Photograph Aquatic Park;  
Historic Documents, Photograph Collection,  
San Francisco Maritime National Historical  
Park; Google Earth; Field Documentation  
2005-2009; 2005 Aerial Photograph,  
Aquatic Park, Pacific Aerial Survey

## Notes

Symbols depicting materials and locations for plant materials are schematic. Placement and general concepts are presented as a way to amplify and illustrate written recommendations in the *Cultural Landscape Report, Aquatic Park*.

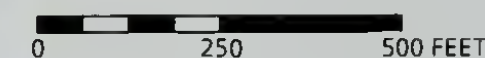

Cultural Landscape Report:  
Aquatic Park

San Francisco Maritime  
National Historical Park  
2010

National Park Service  
Pacific West Region  
Cultural Landscape Program





# RECOMMENDATIONS

## Core Area

The Core Area of Aquatic Park is defined as the extant contributing portions of the historic designed landscape, covering the area between Van Ness Avenue and Victorian Park from Beach Street to the cove. The Core Area includes the primary historic structures—the Bathhouse and associated bleachers, convenience stations, Municipal Pier, the speaker towers, retaining walls, circulation routes, Van Ness Avenue, and planting beds throughout the park.

The key character-defining components of the Core Area are the distinctive Streamlined Moderne style of the buildings designed by William Mooser Jr., and the modern site design by John Punnett. The site plan, redeveloped by John Punnett over several years, focused on clarity of landscape materials and forms to complement the architectural style of the buildings and enhance the relationship between the buildings and the landscape. Characteristics of the Streamlined Moderne style as expressed in the landscape include the emphasis on level, graded terraces and horizontal lines creating the ground plane, rounded edges, and curvilinear forms in the layout of walkways and circulation patterns, the location of planting beds at the base of structures or along walkways providing transition areas, and a manicured appearance throughout.

The plant materials installed in the park over several years also embodied modern design principles such as simplicity of form and color, emphasis of horizontal lines, and soft flowing contours. The restrained planting palette of open lawn and massing of shrubs, and trimmed hedges with few strategically placed trees not only complemented the Streamlined Moderne style of the park, it also maximized open space and views, allowing large numbers of visitors to use the park. Together, the buildings and structures, circulation features, grading and site layout, restrained plant pallet, and limited use of small-scale features created a coherent and distinctly modern aesthetic.

Treatment recommendations for the Core Area emphasize preservation, stabilization, and repair of significant landscape characteristics and features. In some cases, restoration of non-extant historic features is

recommended when deemed critical to the overall coherence of the design. To the extent possible all recommendations emphasize preserving the historic character and aesthetic qualities of the historic design within the framework of contemporary park programs and operations, visitor use, and sustainable maintenance.

Recommendations for the Core Area are organized to address Building and Structures, Circulation, and Vegetation.

## **Buildings and Structures**

The historic buildings and structures in Aquatic Park create the physical framework and dominant aesthetic for the designed landscape. During the period of significance, the clean lines of the Streamlined Moderne style buildings were mirrored by the simple, understated landscape structured by stepped terraces, the sweeping alignment of the Municipal Pier, curvilinear walkways and broad promenades, and contained plantings. Within Aquatic Park, 10 historic structures contribute to the significance of the district.<sup>1</sup>

Several documents provide guidance for the treatment of structures in Aquatic Park, and while it is beyond the scope of this report to address architectural and engineering issues for individual buildings, this report does make recommendations related to the condition and treatment of building exteriors and adaptive, compatible use. Several environmental and maintenance factors, such as peeling paint, rust stains, mildew, water damage, and damaged architectural components, affect the exterior appearance of individual structures and diminish the historic character of the landscape.

Recommendations for treatment of Aquatic Park buildings and structures focus on maintaining the exteriors of historic buildings and promoting appropriate adaptive use of the structure to the degree that the use may affect the design attributes of the park landscape. Recommendations for circulation and vegetation associated with specific historic structures are described below, under recommendations for “Circulation” and “Vegetation.”

## General Guidelines

- Maintain and preserve the remaining historic structures that contribute to the significance of the district.
- Preserve the spatial relationship among historic structures in Aquatic Park. The addition of new buildings within the Core Area is strongly discouraged. If new structures are required for park operations or public infrastructure, such as the proposed historic street car from Fisherman’s Wharf to Fort Mason through Aquatic Park, every effort should be made to locate the new structures outside the Core Area. New structures sited adjacent to or in proximity to the National Historic Landmark District (the district) have the potential to adversely affect the integrity of the district. Basic mitigation measures may include:
  - Ensuring that the design of new structures and site features such as benches and light fixtures are compatible in scale, design, workmanship, materials, and color to the design attributes of the existing historic structures.
  - Ensuring that all new development is undertaken in compliance with *The Secretary of the Interior Standards for the Treatment of Historic Properties*.
  - Using vegetation to selectively screen new structures and reduce visual impacts within the context of the historic designed landscape. The selection and placement of plant materials should be compatible with the type, distribution, and character of historic plantings during the period of significance. (See the section, “Recommendations: Vegetation.”)
- Preserve, rehabilitate, and restore historic structures within the context of park planning and management documents. Implement all treatments in accordance with *The Secretary of the Interior’s Standards for the Treatment of Historic Properties*.
- Undertake all preservation maintenance work on historic structures in collaboration with a historical architect or appropriate preservation specialist to ensure compliance with preservation standards and guidelines.



- Ensure that all rehabilitation or potential adaptive use of historic structures is considered within the context of the historic designed landscape and the degree to which the adaptive use is compatible with the historic character of the park. New uses that limit public access or uses that adversely affect historically compatible activities (recreation) are strongly discouraged.
- Incorporate the use of sustainable materials for selected components of building exteriors as appropriate. New features should be considered only when they are compatible and affect a significant long-term benefit for reducing park maintenance. Decisions to substitute or replace building features and materials should be undertaken only in consultation with a historical architect.
- Maintain historic structures as part of a preservation maintenance program through the Facility Maintenance Software System (FMSS). Identify cyclic maintenance activities for building exteriors. Some of these activities may include:
  - Inspecting paint surfaces and removing significant stains, blemishes, and graffiti.
  - Repainting building exteriors as needed to maintain a clean white appearance.
  - Inspecting and repairing damage to concrete, stone, and mortar materials.
  - Inspecting and repairing rust and corrosion on metal surfaces.
  - Inspecting for water damage, clearing debris and accumulations around foundations from soil displacement.
  - Inspecting and maintaining plant materials around buildings to ensure that roots and branches are not damaging the structure.

## Treatment Recommendations

### Bathhouse

The Bathhouse underwent a rehabilitation project between 2006 and 2008 to address the windows and roofing systems. The

building was painted in 2008. Maintenance requirements for the building will be determined based technical specifications from these projects. Recommendations below address maintenance of exterior areas. Recommendations for reestablishing planting beds associated with the Bathhouse and bleachers are addressed in the section, “Recommendations: Vegetation”.

- Inspect building exterior surfaces annually to identify immediate maintenance needs such as broken glass, roof leaks, vandalism, deterioration of surface materials, drainage problems, and rust or corrosion to metal surfaces.
- Clean building exterior annually, or as needed to maintain a clean, white appearance.
- Develop appropriate maintenance activities for preservation of all exterior surfaces including painted surfaces, windows and metal sashes, railings, and other components and features.
- Restore and maintain the historic slate façade on the south side of the building as the primary entrance to the building. (Figure 86)
- Restore the historic planting beds on both sides of the entry (see the section, “Recommendations: Vegetation, Bathhouse Plantings”).
- Complete rehabilitation of the fountains on the front (south) façade of the building and complete conservation of the stone and mosaics. (Figure 87)



**Figure 86** Front façade of the Bathhouse. View looking north. (NPS, 2006)



**Figure 87.** One of the two fountains that flank the entrance to the Bathhouse and could be restored as part of an overall landscape rehabilitation. (NPS, 2006)



**Figure 88.** Northeast side of the entrance to the Bathhouse with a variety of non-compatible features such as benches, trash cans, city street signs, utilities, and public mailbox. (NPS, 2010)



**Figure 89.** On the west side of the front entrance to the Bathhouse, a bicycle rack, accessibility ramp, and various small-scale features and utilities create a cluttered appearance. Note asphalt paving where planting bed was originally located. (NPS, 2010)

- Inspect the building foundation annually to ensure the integrity of water barriers where planting beds are located.
- Assure building utility systems and features are integrated into the restoration of planting beds in front of the Bathhouse (see the section, “Recommendations: Vegetation, Bathhouse Plantings”). (Figure 88)
- Relocate the benches and bike rack currently located in front of the building to the west side of the structure near the Upper Promenade. These small-scale features should be clustered on either end of the building to the degree possible when the planting beds are restored. (Figure 89)
- Maintain public access to the Bathhouse and retain mixed uses within the building for interpretation, museum collections, offices, and the San Francisco Senior Center.

### West and East Bleachers

Both the East Bleachers and the West Bleachers were part of the Bathhouse rehabilitation project. The project involved significant repair work to the west half of the East Bleachers (called the center bleachers in rehabilitation documents), the West Bleachers, and nearly the complete demolition and rebuilding of the east half of the East Bleachers. The project also repaired and updated underground spaces, improved waterproofing on the bleacher retaining walls and underground roof, and replaced the skylights. Future treatment and maintenance requirements for the building will be developed based on technical specifications from the rehabilitation project. The following recommendations address maintenance of exterior areas.

- Inspect the bleachers annually to ensure the surfaces of the structure remain in good condition.
- Remove vegetation growing in cracks and breaks in the concrete. Repair and paint damaged concrete surfaces as needed using appropriate materials. (Figure 90)
- Maintain pedestrian access to the bleachers from adjacent areas and walkways.



- Add safety rail across the opening located in the center south wall of the East Bleacher.

Recommendations for vegetation and circulation associated with the bleachers are addressed in the section, Recommendations: “Vegetation” and Recommendations: “Circulation.”

### Municipal Pier

The Municipal Pier has several significant structural issues that the park is investigating in order to develop treatment alternatives for stabilization and rehabilitation. Historically associated with the pier, a variety of small-scale historic features remain on the deck of the pier. Many of these features show signs of degradation such as deteriorating concrete on the parapet and curbs, exposed and corroding rebar and pipes, damaged or missing concrete benches, and damaged historic light fixtures. These small-scale features are considered part of the original design and should be repaired in coordination with the future treatment of the pier.

- Conduct a Historic American Engineering Record (HAER) study before further deterioration and prior to any major construction work on the pier.
- Employ stabilization measures based on the condition assessment, and as recommended by a structural engineer or other qualified professional.
- Preserve existing historic features along the pier that are in good condition until treatment options are determined.
- Ensure that public access along the pier is part of any long-term treatment plan.
- Consideration should be given to restoring and/or rehabilitating site furnishings along the decking of the Municipal Pier based on the preferred treatment for the structure. Replacement of these features with replica or “period” furnishings is not recommended. (Figure 91)
- Prepare a comprehensive maintenance plan for Municipal Pier based on the preferred treatment. In addition to cyclic activities related to



**Figure 90** View of the East Bleachers showing new waterproofing material applied during rehabilitation. Note mildew on the concrete wall. Cleaning and repainting this portion of the structure is important to the character of the structure, and should be integrated into overall maintenance. (NPS, 2009)



**Figure 91.** Historic concrete bench, parapet walls and curbing, light standards, and other site features associated with the Municipal Pier. (NPS, 2007)

maintenance of the structure, the plan should also address impacts from visitor use, maintenance of small-scale features including the decking, parapet, curbs, benches, light fixtures, interpretative structures, and the [unfinished] convenience station at the end of the pier. All treatments should be undertaken in consultation with a historical architect or structural engineer, and in accordance with *The Secretary of the Interior's Standards for the Treatment of Historic Properties*.

### Convenience Stations

The two historic convenience stations in Aquatic Park no longer function as public restrooms, and the interior spaces are used by the NPS for storage. Both structures have exterior surfaces that are in poor condition with visible staining and damage to the painted surfaces.

- Stabilize the interior and exterior of the convenience stations such that no further damage occurs.
  - Work in collaboration with a historical architect to repair and replace downspouts as needed to ensure positive drainage away from the structure.
- Inspect and clean the building exterior to maintain a clean, painted [white] appearance.
- Perform recurring and immediate maintenance such as removing graffiti, repairing damaged concrete, or mitigating drainage problems as needed.
- Conduct inspections of exterior fixtures, railings, windows, and window sashes. Clean and repair as needed. The use of rust-resistant hardware is encouraged where possible and appropriate to reduce maintenance. Undertake replacement of external building fixtures and repairs to the concrete façade of both buildings in consultation with a historical architect. (Figure 92)
- Consider rehabilitation of the East Convenience Station and the West Convenience Station to better integrate the function of these historic structures within the park. Rehabilitation or adaptive use should be

in accordance with *The Secretary of the Interior's Standards for the Treatment of Historic Properties*. Adaptive uses for these structures should be considered within the framework of historic use to the degree they are maintained as public buildings.

Recommendations for plantings associated with both convenience stations are provided in the section, Recommendations: "Vegetation."

### Speaker Towers

The West Speaker Tower and the East Speaker Tower both show degradation of the painted exterior surface. The East Speaker Tower is also missing the metal grill that originally covered the speaker and the door. (The grill and the door are in storage.)

- Inspect and clean the building exterior annually or as needed to maintain a clean, painted [white] appearance.
- Reinstall the missing metal grill and door to the East Speaker Tower. Inspect and clean speaker covers on both towers regularly and repair as needed. Rust-resistant hardware should be used when appropriate.

### Seawall, Steps, and Stone Curbs

The Seawall and steps that extend the entire length of the cove from the East Convenience Station to the Municipal Pier are generally in good condition, with just a few cracked and missing basalt blocks. Stone curbs throughout the site are also in relatively good condition. Exceptions are a missing section of curb near the Sea Scouts building and damaged curbs near the West Convenience Station. Recommendations address repair and replacement. (Figure 93)

- Replace missing basalt blocks with historic materials. If historic materials are not available, replace with basalt blocks that are compatible with the historic material including size, color, and surface texture.
- Repair cracked or missing mortar in the wall using appropriate materials and compatible techniques. Care should be taken to match



**Figure 92.** Staining on the exterior of the West Convenience Station. (NPS, 2007)



**Figure 93.** One of the earliest structures built during the historic period, the Seawall around the cove is in relatively stable condition. (NPS, 2009)



the color, aggregate size, and recess profile of the historic mortar.

- Replace the missing portion of the stone curbs as needed using compatible materials and appropriate restoration techniques. (Figure 94)
- Repairs to all historic stonework should be done in consultation with a historical architect or preservation mason.

**Figure 94** Missing block curbing at the West Convenience Station should be repaired using in-kind materials. (NPS, 2007)



### Beach Promenade Retaining Wall

The low concrete retaining wall that borders the Beach Promenade from the West Bleachers to the West Convenience Station shows signs of wear, exposure, and damage resulting from use by skateboarders and bicyclists (“grinders”). Some of the hardware installed on the eastern portion of the promenade wall to discourage skateboarders has broken off, damaging the wall. Recommendations address repair and maintenance.

- Preserve and protect the integrity of the Beach Promenade Retaining Wall.
- Discourage recreational use by skateboarders. Maintain the use of deterrent bolts on the wall to prevent damage. Although currently damaged in places, existing bolts appear to deter many skateboarders. (Figure 95)
  - Repair damaged portions of the wall where deterrent bolts have broken or given way. Replace bolts as needed along repaired portions of the wall. (Figure 96)
  - Extend the placement of deterrent bolts along the entire portion of the wall contiguous with the railroad right of way, from the eastern end of the wall to the point where it diverges from the path. If a different style deterrent bolt is required at a future date, replace existing bolts to ensure material consistency along the entire length of the wall. Select a style of deterrent bolt that has a simple and visually unobtrusive design (see Appendix C).
- Conduct regular inspections of the retaining wall to identify potential structural issues or damage to the concrete and painted surface. Repair damaged concrete in kind, matching materials and finish. Repaint when stabilized.

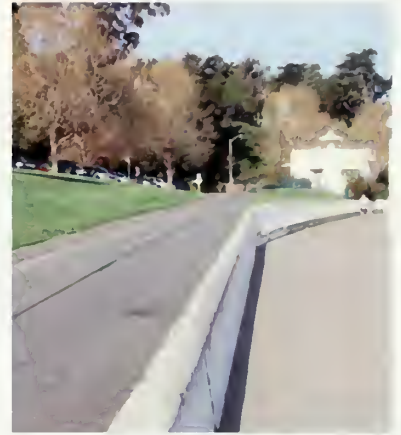

**Figure 95** Concrete retaining wall between the Beach Promenade and the State Belt Railroad tracks. View looking west (NPS, 2007)



**Figure 96** Flaking and loss of material along the concrete wall occurs as deterrent bolts fail and water penetrates the under layers of the concrete. Repair may require patching, reapplication of a skim-coat, or some combination. View of the east end of the wall, looking west (NPS, 2007)

## Stone Retaining Wall



**Figure 97.** Remnant features of the original stone retaining wall as it wrapped around the park to Van Ness Avenue. View looking south. (NPS, 2008)

The stone retaining wall that borders the Bocce Ball Courts was one of the earliest structures built during initial construction of Aquatic Park. It was built to accommodate site grading for the extension of Van Ness Avenue and the State Belt Railroad grade. Based on historic photographs, the original wall was considerably longer than it is today and the grade difference from one side of the wall to the other appears to have been as much as 20 feet. The city water pumping station was located on the lower side of the wall where the Bocce Ball Courts are today. Photographs indicate that the wall was shortened in 1937 when additional grading was done to accommodate construction of new park buildings. Around 1942 the pumping station was removed and the area on the south side of the wall was backfilled, leaving only approximately 4 feet above grade at its highest end. The wall remains distinctive today for its stone construction and the granite acorn bollards on top of the wall. (Figure 97,98)

- Inspect the wall annually to identify potential structural issues and damage to the stone surface. Repair damaged components in kind, matching materials and finish.
- Integrate preservation maintenance activities for inspection and preservation of the wall into FMSS.
- Ensure that any future park development affecting the historic character of the stone retaining wall (such as development of historic



**Figure 98.** View of the stone retaining wall looking northwest from the lawn near the Bocce Ball Courts. The amount of exposed wall visible in the park today generally slopes to the east based on fill added to even the grade when the pump house was removed in the 1940s. (NPS, 2008)



streetcar tracks and a stop in this area) is considered and evaluated within the context of the historic designed landscape and potential affects to the NHL district.

- Assess potential adverse effects of new park development affecting the historic design of the stone retaining wall, and develop appropriate mitigation measures in consultation with a historical landscape architect and/or cultural resource staff.

## Circulation

The circulation system at Aquatic Park is an integral and structuring part of the landscape design, facilitating the movement of large numbers of people through the park. The curvilinear paths and streamlined shapes of the walkways and the use of concrete with clean edges mirrors the modern building forms.

Based on historic images, aerial photographs, and existing conditions it appears that concrete was used as a finish surface material for several walkways, including the Beach Promenade, stairs, and vehicle ramps around the Bathhouse, the Van Ness Avenue extension, and the sidewalk along Beach Street. Some walkways appear darker in historic photographs, indicating that other materials such as gravel, macadam, oiled gravel, and asphalt may have been used around the East Bleachers and on the Upper Promenade. In some locations, numerous repairs to the asphalt walkways have altered the physical extent, dimension, and character of the original surfaces.

Also in some areas, notably around the East Speaker Tower and along the Upper Promenade just west of the West Bleachers, raised curbs and rolled asphalt curbs have been added. These non-historic curbs, while small in scale, are inconsistent and not compatible with the clean, neat edges that are characteristic of the historic walkways.

As a part of the urban and recreational waterfront of San Francisco Bay, Aquatic Park receives heavy pedestrian traffic. Walkers, joggers, bicycles, skateboarders, commuters, in-line skaters, and other users can create congestion, user conflicts, and potentially hazardous situations along the Beach Promenade and adjacent areas.

Treatment recommendations for the circulation system in Aquatic Park focus on repair and replacement of inappropriate paving materials, removal of non-historic accretions, and reducing conflicts among diverse users within the framework of the historic design.

## General Guidelines

- Preserve the designed hierarchy of historic circulation patterns in Aquatic Park including the promenades, walkways, and transition areas (steps and ramps). This hierarchy is historically significant and remains functional today, reflecting the Streamlined Moderne design as applied and implemented in the site plan for the park. In general, the dimension of individual walkways throughout the park should also reflect a gradation in width, from primary to secondary paths.
  - Maintain the current alignment and width of the Upper Promenade, Beach Promenade, and Van Ness Avenue extension as primary historic circulation structures linking the park with adjacent areas. (Figure 99 )
  - Maintain the current alignment of asphalt walkways within the park as the second level in the hierarchy of circulation, connecting use areas and routing visitors through the park.
  - Maintain ramps and stairs providing connections between walkways and promenades as the third level in the circulation hierarchy, critical for transitions between grades and the upper and lower terraces of the park.
- Inspect the condition of historic walkways throughout the park on a routine basis. Include annual inspections as a preservation maintenance activity in FMSS.
- Repair walkways determined to be in poor condition due to cracked or broken surface pavement, displacement from water or vegetation, loss of distinct and defined edges between the walk and vegetated areas. Whenever possible, repairs should be completed as part of an overall rehabilitation strategy for the circulation system holistically.
  - Monitor the number of spot patches to individual walkways to ensure that the aggregate effect of repeated patching does not compromise the character and integrity of the primary

**Figure 99.** A slight realignment on Van Ness Avenue for bicycles routing through Aquatic Park provides a simple mechanism to slow the speed of cyclists and reduce potential conflicts with pedestrians.



- paving material. (Figure 100)
  - Remove excess paving material in places where past repairs have altered the historic width, alignment, material, edge treatments, or character of the historic walkway.
  - Maintain a defined clean edge between walkways and lawn areas. Consider the use of flexible metal strip to create a stable and clean edge between paving and turf or planting beds as needed. Plastic edging is not recommended. (See Appendix D.)
  - Remove weeds and grass from cracks in the concrete and asphalt to ensure a clean, manicured appearance compatible with the character of the historic design.
- Maintain consistent and uniform material selection for future repairs to historic walkways and promenades.
- Repair concrete elements using concrete, taking care to match color and finish texture with the existing material. Date-stamp new concrete to distinguish it from existing materials.
- Remove the raised asphalt and pre-formed concrete curbs around the East Speaker Tower and along the Upper Promenade. If curbs are currently needed to control water run-off and drainage, a low, narrow profile concrete curb is more compatible with the historic character and should be used in place of rolled asphalt curbs or pre-form concrete. (Figure 101)



**Figure 100** In some areas walkways have been resurfaced with paving added over existing layers creating a patchwork of materials. (NPS, 2008)





**Figure 101.** Rolled asphalt curbing along the Upper Promenade. View looking west. (NPS, 2008)

- Work with a historical architect to provide universal access to historic structures as needed.
  - Redesign the Beach Street sidewalk and main building entrance to meet ADA requirements.
  - Consider providing access to the Bathhouse through the east entrance of the building.
  - Maintain the existing [compatible] ramp located at the front entrance until a new permanent access is completed.
- Ensure positive drainage on paved surfaces around all structures.

## Treatment Recommendations

### Beach Promenade

The Beach Promenade is the primary circulation feature routing visitors through Aquatic Park. Historically designed as a broad leisurely path, it was aligned to follow the sweeping shoreline of the cove between the basalt cobble Seawall and the larger park landscape. Today the Beach Promenade is used by walkers, joggers, and bicyclists and remains a significant character-defining structure of the park circulation system.

- Maintain the historic design of the Beach Promenade including the width, alignment, and concrete finish surface.
- Maintain the concrete surface in good condition.
- Inspect the Beach Promenade annually to identify wear, damage to the finish surface, and possible safety concerns associated with displacement, old paving patches, and broken concrete.
- Repair cracks as needed to ensure a safe surface and control weeds and grass that may grow where the concrete is displaced.
- Replace existing asphalt patches with concrete material, matching the original color and finish. If additional areas of the Beach Promenade require repair in the future, ensure that replacement materials and finishes are compatible and match the existing concrete paving.

## State Belt Railroad

During construction of Aquatic Park, the State Belt Railroad tracks were realigned to follow the curve of the Beach Promenade before climbing the grade west to the Fort Mason tunnel. At this time the rail tracks that ran along the Beach Promenade were anchored to the concrete paving. From a point at the west end of the cove where the tracks diverged from the promenade, the rails were secured to timber sleepers set on an earthen or gravel bed. After the railroad ceased operation in the 1970s, the rail bed through Aquatic Park and across Van Ness Avenue was paved over with asphalt. On the segment between the Beach Promenade and Van Ness Avenue, asphalt was used to pave the entire 12-foot wide right-of-way including the space between the rails.

The elastic nature of the asphalt paving has a tendency to make it sag and separate around the rails. Today the uneven character of the rails and the asphalt bedding around them has the potential to create safety issues for bicyclists and other users of the park. Heavy truck traffic and frequent patches to the asphalt exacerbate the safety issue and create an adverse visual impact. (Figure 102)

- Replace existing asphalt paving around the State Belt Railroad tracks with concrete to create a more stable surface and track bed.
  - Ensure that new concrete pavement is finished flush with the top of the rails, without gaps, and the top of the rails are visible on the surface of the pavement.
  - Use a compatible concrete material, and finish for all future repairs and patches to the rail bed along the Beach Promenade, ensuring a smooth and level surface at grade.
- Maintain lawn and/or vegetation adjacent to the rail line to clearly delineate the historic dimension and edge of the alignment.
- Repair areas where impervious surface materials such as asphalt, gravel, or compacted earth have spread beyond the original edge of the walk and prevent the growth of vegetation. Replant with sod with mesh or geo-tech underlay to support edge treatments as needed.

**Figure 102.** In most cases the separation between bicycles routed on the upper walkway and tracks (left) and pedestrians along the shoreline on the Beach Promenade helps mitigate potential pedestrian/bicycle conflicts. Over the years, asphalt paving and patching around the tracks has created uneven surfaces and in some cases, presents safety hazards. This view looking west. (NPS, 2005)



- Ensure that the edges of paved surfaces are free of leaf litter and debris that might obscure the line of the pavement. Remove grass and weeds from the cracks in the asphalt or concrete.
- Install new edging material as needed to ensure integrity of both the walkway edges and turf grass.

### Upper Promenade

The Upper Promenade is a primary walkway connecting the west end of the Bathhouse with Van Ness Avenue, following the upper terrace near the Bocce Ball Court area. Historically the Upper Promenade may have been paved with macadam, oiled gravel, or asphalt. Over time several incompatible repairs and asphalt patches of various dimensions have affected the historic character and design dimension of the Upper Promenade. Recommendations address rehabilitation of the Upper Promenade and the sidewalk on the west side of the Bathhouse.



- Restore the segment of the Upper Promenade along the Bathhouse immediately west of the terrazzo paving after restoring the planters. (See “Recommendations: Vegetation, Bathhouse Plantings”.)
  - Resurface the walkway using concrete paving along the front façade of the Bathhouse (matching the paving on the east side), to the point where the Upper Promenade turns toward Van Ness Avenue (west of the ramp). Date-stamp new paving to differentiate it from existing materials. <sup>2</sup> (Figure 103)
- Restore the historic character of the Upper Promenade from the west side of the Bathhouse to Van Ness Avenue.
- Rehabilitate and repave the Upper Promenade from Beach Street west using asphalt or other compatible material and following the original alignment of the walkway. The promenade should be repaved in its entirety when patching becomes excessive.
- Ensure that the edges of the Upper Promenade are clearly delineated and free of leaf litter and debris. Maintain lawn and/or vegetation to the edge of the walkway.

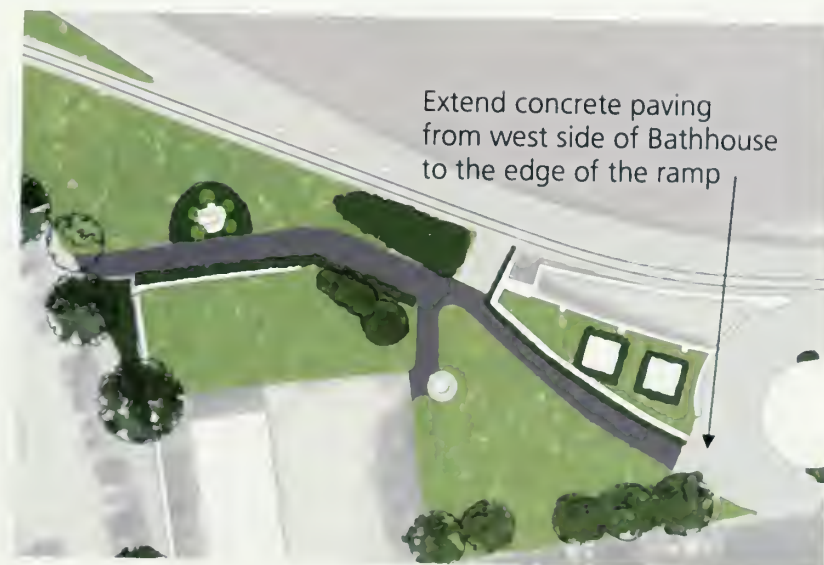

**Figure 103** Plan view showing the extension of concrete paving west of the Bathhouse to the beginning of the Upper Promenade (NPS, 2007)

- Rehabilitate areas where asphalt, gravel, or compacted earth have migrated beyond the edge of the promenade and are preventing vegetation growth. (Figure 104)
- Ensure that any future park development affecting the historic character of the Upper Promenade, such as development of a streetcar stop in this area, is considered and evaluated within the context of the historic designed landscape and potential impacts to the NHL district.
  - Assess potential adverse effects of new park development affecting the historic design of the Upper Promenade and develop appropriate mitigation measures in consultation with a historical landscape architect and/or cultural resource staff.

### Walkways behind East Bleachers

The walkways located directly behind the bleachers and around the skylights are part of the original design implemented by the WPA between 1936 and 1939. These walkways were initially paved using macadam, oiled gravel, or asphalt. At some point, asphalt was used to pave under the Monterey pine tree located near the center of the bleachers.

The walkways located east of the East Speaker Tower and along the east edge of the East Bleachers currently define the boundary between the



**Figure 104** View of the Upper Promenade showing the rolled curb along the edge of the walkway and planting bed (left), and the patching and expansion of paving leaving a relatively undefined edge on the right side. (NPS, 2006)

historic designed landscape of Aquatic Park and Victorian Park. During the period of significance this area was considered “unfinished” and photographs indicate only informal paths and social trails in the area until the 1950s. When Victorian Park was constructed in 1962, informal paths in this area were widened, realigned, and surfaced with asphalt to create a seamless connection between the two parks. Although compatible, these walkways are not historic and do not contribute to the significance of Aquatic Park. Rehabilitation of these non-historic walkways should focus on contemporary use, accessibility, carrying capacity, and compatibility with the historic circulation of Aquatic Park.

The walkways located east of and behind the East Bleachers are part of the bleacher rehabilitation project (2009). The following recommendations support rehabilitation of the landscape behind the East Bleachers as noted in construction documents for the project. (See Appendix E)

- Restore the historic configuration, alignment, and width of walkways behind the East Bleachers as part of the rehabilitation of the East Bleachers.
  - Add a new access walkway on the west side of the East Bleachers between the skylights. (Figure 105)
  - Widen the paving at the center gap in the East Bleacher wall for compliance and accessibility.
  - Restore walkways from the East Speaker Tower westward to their original alignment. (This recommendation is included in the bleacher rehabilitation plan.)
- Restore and maintain the edges of paths to be clear of sand, leaf litter, and debris that may inhibit plant growth or obscure the pavement edge. Maintain lawn and/or planting beds to the edge of the asphalt walkway.
  - Rehabilitate areas where asphalt, gravel, or compacted earth have migrated beyond the edge of the paths and are preventing plant growth.
  - Install edge treatments as needed along paths to provide a neat and defined edge between the paths and turf grass or mulch areas. (See Appendix D)

**Figure 105.** Plan view showing the areas behind the East Bleachers. (NPS, 2007)



- Minimize the future surface patching of walkways in this area. When paving repairs become extensive, consider overall rehabilitation using either a slurry coat and chip seal or other material that is visually compatible with other walkways in the park.
- Remove the raised asphalt curb around the East Speaker Tower and replace with a simple asphalt pavement edge that is flush with the walkway. Correct drainage by re-grading adjacent beds or ground plane. If structure is still required to control runoff, use a low, formed-concrete edging material in a manner consistent with the curbing used on the west side of the site. (Figure 106)
- Remove the asphalt paving in the area of the removed Monterey pine tree (*Pinus radiata*) and reestablish lawn. Plant a new Monterey pine tree (*Pinus radiata*) and add mulch material around the trunk. (See Recommendations: “Vegetation”)

**Figure 106** Raised asphalt curb around the East Speaker Tower planting bed. (NPS, 2008)



### Bathhouse Ramps and Plaza

Paved ramps on the east and west sides of the Bathhouse and the plaza on the north side of the building are designed elements depicted in Punnett’s original site plan. Today the ramps provide vehicular access between Beach



Street and the Beach Promenade, and facilitate vehicular access to the lower level of the Bathhouse. Over the years and since 1945, a portion of the plaza area has been used for parking. As part of the effort to reestablish the historic scene in this area, the practice of parking cars in this area was discontinued by the NPS in early 2007.

- Retain limited access using the ramps for emergency vehicles and using removable bollards as appropriate to control access. Continue the restriction on vehicular parking in the plaza area.

### Beach Street Sidewalk

The primary impact to the sidewalk along Beach Street between Victorian Park and the terrazzo segment in front of the Bathhouse is the bus stop on Beach Street and the degree to which the city bus has adequate space to operate. Significant wear and damage to both the designated bus lane and to the curb and concrete sidewalk immediately adjacent to the bus stop has, over time, damaged the sidewalk and adversely affected the overall setting (appearance) in front of the Bathhouse. (Figure 105, a&b) Until this issue can be addressed in a larger planning process with all stakeholders, the following recommendations may be considered.

- Rehabilitate and maintain the Beach Street sidewalk and curbing in good condition.
- Work with appropriate agencies to identify and improve conditions creating adverse impacts to the sidewalk and curbing around the bus stop. Improvements may include some or all of the following:
  - Ensure a maximum and constant height for the curb along the sidewalk to reduce impacts from busses hitting the curb.
  - Consider reducing the number of parking spaces immediately east of the bus stop to allow more space for the bus to maneuver into the bus lane without hitting the curb and sidewalk.
  - Resurface the street or bus lane with a more sustainable material, such as concrete, to mitigate the impact of heavy vehicles and traffic on the street and curbing.



**Figure 107 a&b.** The bus stop located on the east side of the Bathhouse is an area significantly impacted by heavy use in a relatively compact zone. Overall, the combination of degraded concrete sidewalks, denuded vegetation, damaged concrete curbs, visually incompatible structures, and a diverse variety of small-scale features create an adverse impact to the NHL district. View from the shelter looking east along Beach Street. (NPS, 2006)

- Relocate the bus shelter north of the current sidewalk to create additional space for pedestrians waiting for the bus.
- Work with the city to relocate or remove the current bus stop as a way to mitigate impact to Aquatic Park and the NHL district.

### Van Ness Avenue

During initial construction of Aquatic Park, an extension to Van Ness Avenue on the west side of the park was constructed to create access to the Municipal Pier. As designed the street extension was 15-foot wide between the Upper Promenade and the decking of the pier. Never intended as a thoroughfare, the street extension also created space for parallel and angled vehicular parking, and a relatively wide strolling area for pedestrians. Today visitors continue to use the area for angled and perpendicular parking (south of the State Belt Railroad tracks) and parallel parking (from the railroad tracks to the pier). Recommendations for treatment of vegetation along Van Ness Avenue can be found in the section, “Recommendations: Vegetation”.

- Preserve and maintain in good condition the historic alignment and dimension of the Van Ness Avenue extension, including the width, material, and finish of the concrete road surface and associated sidewalks.

- Ensure that repairs made to the surface of the extension use concrete that matches the color and finish of the existing material. Date-stamp new concrete surfaces to differentiate them from existing pavement.
- Ensure that sidewalks along Van Ness Avenue are repaired and maintained in good condition. Work with an arborist or horticulturist as needed to determine appropriate treatments for areas of sidewalk pavement displaced by tree roots. All repairs should be made using compatible materials and finishes. (Figure 108)

## Vegetation

As documented in this report, ornamental plantings in Aquatic Park were installed over several years, and although not based on a single plan the selection and placement of plant materials throughout the park appears to incorporate concepts from John Punnett's 1938 site plan. Photographs of the park from the 1940s show a simple and restrained plant palette comprised of large open lawns, masses of low-growing shrubs, and formal hedges creating a landscape character that complemented the sleek modern lines of the buildings. After 1945 incremental changes and losses due to changing management and maintenance practices, and impacts from visitor use, significantly altered the composition of plant materials. Today very few of the original plantings remain in the park and the remaining plant materials, although somewhat compatible, no longer reflect the overall composition and design aesthetic of the original site plan.

Recommendations for the treatment of ornamental vegetation in Aquatic Park are based on photographs and aerial images from the period of significance and shortly after. Because historical information is inadequate to support full restoration, recommendations emphasize rehabilitation to enhance historic character through the renovation of open lawn areas and the rehabilitation of planting beds, including replacement of selected shrubs, hedges, and trees.

Although specific plants cannot be easily identified using historic records, what is evident in the historic photographs and what provides a basis for determining treatment for plant materials are the location, extent, and character of vegetation during the period of significance. (Figure 109 a&b)



**Figure 108** Displaced, cracked, and patched sidewalk along Van Ness Avenue next to Pocket Park. At a certain point, rather than patching, a holistic approach to rehabilitation of the sidewalk will assure a more uniform character. View looking south (NPS, 2008)



Recommendations for the treatment of plant materials address the following issues:

- Is the replacement plant material compatible in form, size, habit, and character to the vegetation documented in historic photographs?



**Figure 109 a&b.** Comparison showing the degree to which vegetation has encroached on the slope above Van Ness Avenue (Fort Mason). Historically this area had a more open vegetative character during the period of significance for Aquatic Park. Top: view looking west, 1946. (Courtesy of the San Francisco History Center, San Francisco Public Library AAA 6697; bottom: view looking west, 2009 (NPS, 2009)



- Is the new plant material sustainable (in terms of water and maintenance requirements) and are there substitute materials that can provide compatible alternatives?
- Is the new material appropriate within the context of the overall historic designed landscape?

Replacement of historic plant material in the park is considered based on three criteria:

- **Condition**—The plant is in such poor condition that it will take more than five years to rejuvenate it to the desired character,
- **Uniqueness/specificity**—The plant does not represent a unique horticultural specimen or specific intent in the selection or placement,
- **Maintenance**—The plant requires exceptional maintenance (active pruning to control shape and size) in this setting and the environmental impacts from public use create conditions that cannot support the development of healthy plants.

In most cases rehabilitation of plant materials requires the renovation of planting beds including the addition of soil amendments, organic materials, and irrigation to enhance establishment.

It is important to recognize that while individual plantings are important components of the landscape design, preservation of the modern aesthetic at Aquatic Park requires that planting beds and landscaped areas be maintained in good condition with uniform and neatly trimmed hedges, irrigated green lawns, and healthy shrubs pruned to maintain natural growth habit or intended forms. This “manicured” or maintained appearance is a tangible and significant component of the park’s historic character.

Park-wide recommendations are organized to address lawn areas, planting beds, hedges, and trees.

## General Guidelines

- Work with a historical landscape architect to develop a schedule for inspection and condition assessments of ornamental plant materials as features under the Maintained Landscapes Assets in FMSS.

- Prepare a Project Management Information System (PMIS) statement for a comprehensive landscape rehabilitation of the Aquatic Park landscape. The proposal should address all components of the designed grounds and focus on the rehabilitation of planting beds and walkways throughout the park.
- Work in collaboration with Golden Gate NRA to remove invasive vegetation covering the slope above Van Ness Avenue. Historically this hillside was considerably more open in character. Historic structures such as walkways, stairs, and railings remain from the designed landscape associated with Fort Mason but are largely obscured by vegetation.

## Treatment Recommendations

### Lawn Areas

Many of the lawn areas in Aquatic Park date from the historic period, including: areas on the west end of the park around the West Speaker Tower, West Convenience Station, and in front of the Sea Scouts building; around the skylights on the terrace above the West Bleachers; and behind the East Bleachers. As a design element, lawn areas provided open space for recreation and functioned as a relatively low maintenance ground cover that was highly compatible with the modern design aesthetic. Documentation in historic photographs suggest that even during the period of significance, large planting beds initially planted with shrubs were either reduced in size or, in some cases, were replaced entirely and planted with lawn.<sup>3</sup>

Today lawn remains the primary vegetation cover in the park. In many areas adjacent to the intersection of walkways, turf grass is in relatively poor condition due to trampling and compacted soils. In several cases it is missing altogether, leaving heavily compacted dirt.

- Maintain green, irrigated lawns in good condition throughout the park.
- Renovate lawn areas as needed to restore healthy turf grass cover. Integrate sound horticultural maintenance practices and turf

grass renovation activities such as thatching, aeration, and weed control into FMSS.

- Rehabilitate areas along the edge of walkways where grass is in poor condition due to compacted soils from foot or bicycle traffic. This may include, but not be limited to, removing sand and excess paving materials from the edges of walkways, aerating soil, and replanting or re-sodding turf grass.
  - Edge and maintain the areas where the lawn and walkways meet to provide a clearly defined line. Restore the lawn areas located behind the bleachers to reflect the historic character and original design.
- Replace or repair irrigation systems in this area to ensure proper watering cycles and coverage.
  - Investigate water-efficient irrigation systems as a way to reduce the amount of water and general maintenance required to maintain green and healthy turf grass.
- Replacement of existing lawn areas in the park is not recommended. However, if discrete areas of lawn cannot be maintained in good condition due to operational issues or repeated and unmanageable impacts, the following alternatives may be considered in consultation with a historical landscape architect or appropriate cultural resources staff.
  - Investigate the use of alternative turf grass varieties that retain the historic character of a green irrigated lawn, but are more sustainable related to water requirements or more tolerant of heavy traffic.
  - Design and develop new planting beds to replace turf areas that are not sustainable. New shrub plantings should be compatible and uniform in size (approximately 2 feet high), composition, massing, and overall character with other planting areas in the park.



- Discourage the widening of walkways as a means to mitigate turf maintenance issues or increase carrying capacity. Expanding the walkways to replace lawn with the NHL district remains an adverse effect.

## Planting Beds

As depicted in John Punnett's site plan, planting beds in Aquatic Park were located at the corners of walkways and lawn areas and around structures to soften edges. Low-growing shrubs in the planting beds were located at the base of the speaker towers, around the convenience stations, and west of the West Speaker Tower.

Although the specific species of shrub cannot be identified, historic photographs and aerial images of Aquatic Park (1946-1950) depict the location, extent, and character of several shrub beds. Based on an interpretation of this information, shrubs appear uniform in composition, are planted relatively close together in solid masses, and are approximately 2-3 feet high. Many of the shrubs appear to be leafy evergreens, creating a soft mounding effect, pruned so the edges were neat but irregular. With few purposeful exceptions they were not pruned into planer form as a hedge.<sup>4</sup>

Although the majority of historic planting beds remain today, plant materials within the beds have changed over several years. In some cases plants have been maintained to address public health and safety issues rather than aesthetic design. In other cases shrubs have been removed and not replaced, or replaced with non-compatible materials. Collectively these changes have dramatically altered the historic character of the landscaped grounds in Aquatic Park.

Recommendations for planting beds focus on rehabilitating and re-establishing plant material to reinforce the modern aesthetic in Aquatic Park and to strengthen the historical association between the grounds and modern design principles that guided development of the park.

## Planting Beds around the East and West Speaker Towers

Grecian laurels (*Laurus nobilis*) were planted around both speaker towers relatively late in the historic period. Historic photographs from the 1950s

show the laurels as tall shrubs, pruned into vase-shaped forms that taper from a narrow base to a broad flat top.

Photographs depict six laurels in a planting bed around the West Speaker Tower: two on the west side, two on the east side, and one each on the north and south sides. In front of the laurel shrubs on the west, north, and east sides of the speaker tower, low-growing shrubs were planted relatively close together to create a solid massing. Today five laurel shrubs remain around the West Speaker Tower, pruned into oblong mounds roughly 2 feet high and 4-5 feet long. With the exception of a few individually pruned shrubs around the laurels, the majority of the historic plantings are gone. Five laurels remain around the East Speaker Tower.

- Rehabilitate the planting beds around both speaker towers.
  - Amend and replenish soils as needed.
  - Remove and replace in kind existing shrubs in the bed with suitable species.
- Retain the existing Grecian laurels (*Laurus nobilis*) around the West Speaker Tower. Prune and reinvigorate to reestablish the historic character of these materials as a tall, vase-shaped plant. (Figure 110 a&b)



**Figure 110 a&b** During the historic period, Grecian laurels planted around the West Speaker Tower were pruned into an urn-shape, with narrow base and broader top. Recommendations encourage the remaining laurels to be reshaped into a similar form. Left, Detail of historic view looking north from the Bocce Ball Courts, ca. 1952, Right, Concept showing proposed form for pruning existing and newly established laurels.

- Establish low-growing shrubs in front of the laurels around the West Speaker Tower in a manner that promotes a solid and uniform massing within the planting bed. Appropriate shrubs may include materials similar in character to *Raphiolepis indica*, *Lantana*, *Cistus*, or *Rosemarinus officinalis*. Height of the low-growing shrubs should be between 2-3 feet.
- Retain the configuration of the existing planting beds around the West Speaker Tower, but place new shrubs to fill in around the laurels. The low-growing shrubs should cover three sides around the base of the speaker tower from the pavement edge on the west side around the north side to the pavement edge on the east.
- Retain the Grecian Laurel (*Laurus nobilis*) around the East Speaker Tower. Prune as needed to reinvigorate and train into a vase-shaped form, narrower at the base and wider at the top.

### Planting Bed west of the West Bleachers

The planting bed located between the West Bleachers and the West Speaker Tower remains from the historic period. Photographs show the bed contained a uniform planting of low-growing shrubs consistent in character with other shrub massing within the park: low, dark, leafy green shrubs planted together in a solid mass. The existing plants in this bed have fine light gray foliage, significantly different in character from the historic material.

- Rehabilitate the planting bed located west of the West Bleachers. (Figure 111)
  - Amend and replenish soils as needed.
  - Remove the existing *Santolina*.
  - Replant with a medium-size shrub (up to 36" high) similar in character to *Raphiolepis indica*, *Lantana*, *Cistus*, or *Rosemarinus*.
  - Plant new shrubs close together and promote growth to create a solid massing within the bed.
  - Reduce the size of the planting bed to create a more rounded end on the west side. Maintain shrubs in planting beds to a uniform height of 2-3 feet. Shrubs should have a soft,

Figure 111 Planting Concepts, West Bleachers

Cultural Landscape Report: Aquatic Park  
San Francisco Maritime  
National Historical Park  
2010





mounded character, and the edges should be feather-pruned to present a neat, but irregular edge. Shrub masses should be pruned to retain a natural growth habit. They should not be sheered to create flat surfaces.

### Planting Beds around the East and West Convenience Stations

Historic photographs documenting planting beds around the convenience stations depict a foundation planting of low-growing shrubs surrounding the buildings. All images from the later periods suggest the configuration of these beds was altered more than once. Today these planting areas are in poor condition.

- Rehabilitate the planting beds associated with both convenience stations.
  - Amend and replenish soils as needed.
  - Remove the existing plant materials
  - Replant with a medium-size shrub (18-24 inches high), similar in character to *Raphiolepis indica*, *Lantana*, *Cistus*, or *Rosemarinus*.
  - Shrubs should have a soft, mounded character, and the edges should feather-pruned to present a neat, but irregular edge. Shrub masses should not be sheered to create flat surfaces.
  - Plant ground cover around the outside perimeter of shrubs to reduce maintenance, retain moisture, and improve visibility. These materials should be selected in consultation with maintenance staff and a historical landscape architect.

### Hedges

Hedges were an integral component of the overall planting design in Aquatic Park. Used primarily to create, define, or enhance the edges of structures including walls and skylights. Major hedge planting was located along the Upper Promenade stone retaining wall, behind the east and west bleachers, and around the skylights. Although all hedges were pruned to maintain a specific height, only those around the skylights were pruned to have a formal, manicured appearance. From historic photographs these hedges appear to have been composed of a leafy evergreen shrub and were neatly clipped to 3-4 feet in height. (Figure 112) As part of the

bleacher rehabilitation project the bleacher structures will be repaired or replaced and the skylights will be replaced. Recommendations for hedges focus on restoration and rehabilitation to reestablish historic character within the framework of public safety.

## General Guidelines

- Reestablish hedge plantings throughout the Core Area to strengthen the cohesive character of the historic designed landscape. The restoration of hedge planting may be combined with structural elements, such as fences, to address visitor safety.
- All hedges in the Core Area should be consistent in form and character, and when possible, in species. Based on historic photographs, appropriate plant materials for hedges include broadleaf evergreens with relatively small leaves (1-3 inches in length) and medium texture.

## Treatment Recommendations

### Retaining Wall Hedge

The only hedge that remains from the period of significance in the Core Area is the hedge located along the north side of the stone retaining wall on Upper Promenade. Currently this hedge is comprised of *Escallonia*. This hedge appears in historic photographs and aerials during the 1940s, and while it is unknown if the *Escallonia* hedge is original, the form and character of the hedge today is very similar to the character depicted in historic photographs.

- Retain the hedge along the retaining wall on the Upper Promenade north of the Bocce Ball Courts.
  - Prune the hedge to a height below the cap and where the acorns on the wall are visible above the hedge. The hedge should be feather-pruned rather than sheared to retain a natural form and character.
  - Replace individual plants comprising the hedge in-kind and as needed when individual plants fail.



**Figure 112** Detail of photograph showing the historic character of the hedges planted around the skylights on the east side of Aquatic Park, 1953. (San Francisco Maritime NHP, Historic Documents, Photograph Collection, A12 17,546.1)

- Consider extending the hedge on the east end of the wall to reflect the historic extent of the planting. Re-establishment of this portion of the hedge should be based on both long-term treatment of the Bocce Ball Courts, and sustainable maintenance practices.

### West Bleachers Hedges

Like the East Bleachers, a broadleaf evergreen hedge extended along the south wall of the West Bleachers. Similar in character to the hedge along the East Bleachers, when the hedge reached the southwest corner of the West Bleachers, it wrapped around the wall and followed the wall along the steps and narrow planting bed leading down to the Beach Promenade. (Figure 113) Today the hedge is gone and the area between the bleacher wall and the Upper Promenade has been paved with asphalt.

- Restore the hedge behind the south wall of the West Bleachers, around the southwest corner of the wall, and down the steps.
  - Remove existing paving and redefine the extent and dimensions using historic photographs and treatment drawings.

**Figure 113.** Graphically overlaid on a 1948 aerial photograph of Aquatic Park are the hedges located on the west side of the park during the historic period. The hedges wrapped around the stone retaining wall and the wall behind the West Bleachers, stepping down to the Beach Promenade. Recommendations call for re-establishing these hedges. (*Pacific Aerial Survey, 3-10-05, 1948*)

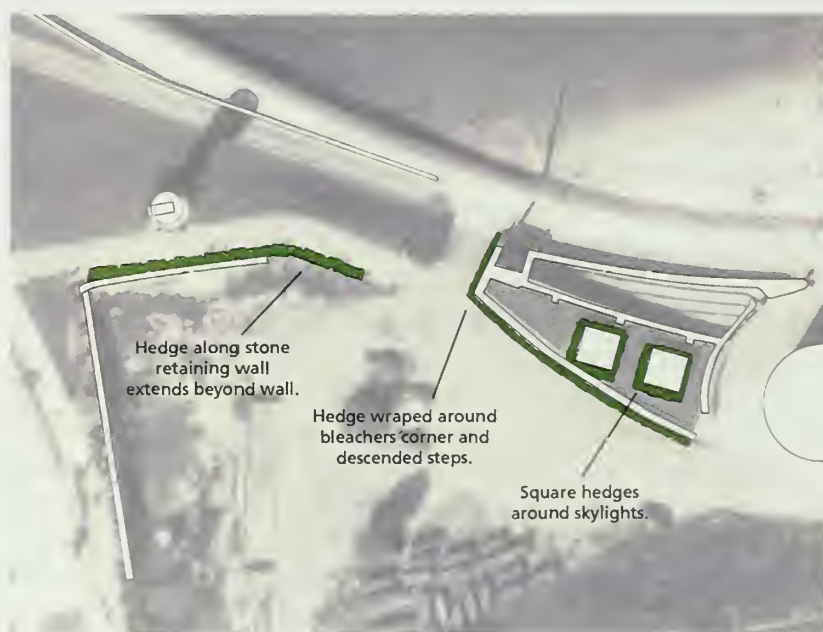

- Amend soils as necessary to reestablish a viable planting medium prior to planting.
- Maintain the hedge at a height of 6-10 inches below the top of the wall.

### East Bleachers Hedges

During the historic period a broadleaf evergreen hedge was planted along the back (south) wall of the East Bleachers, extending the entire length of the wall, and wrapping around the east side. In historic photographs it appears that this hedge was composed of two segments along the bleacher wall with a large gap in the center allowing pedestrian access to the bleachers from the walkways on the upper terrace. The east side of the hedge continued between the two openings on either end of the wall. The hedge continued around the southeast corner of the bleachers and down the side, with an opening for access to the bleachers basement.<sup>5</sup>

- Rehabilitate the planting bed along the bleacher wall by clearly defining the extent and edge of the bed, and supplementing soils as required with appropriate amendments. Mulch the bed to retain moisture and reduce weeds.
- Reestablish the hedge along the south wall of the East Bleachers. Use materials that are compatible with the character of the hedge as it appeared during the historic period such as white escallonia (*Escallonia bifida*), Boxwood (*Buxus sp.*), or other shrubs with a similar growth habit, color, and texture.
  - Mitigate the potential for social trails between the walkway and the bleachers by allowing openings in the hedge associated with walkways as depicted.
  - Prune to maintain the height of the hedge to between 6-10 inches below the top of the wall. Prune the hedge to maintain a structured and formal character. Ensure that hedge plantings do not extend to cover scrollwork on central portion of the bleacher wall.



**Figure 114** Aerial photograph showing the hedges around the skylights behind the East Bleachers, 1948. (*Pacific Aerial Survey*)



### East Skylight Hedges

A continuous, low-growing broadleaf evergreen hedge enclosed all six skylights located on the upper terrace behind the East Bleachers. Around the large skylights, the hedges followed the square perimeter of the structures. Around the smaller skylight, located south of the walkway, the hedges were planted in a circle around the skylights. This configuration for all the hedges is clearly visible in aerial photographs from the 1940s and 1950s. (Figure 114) Sometime before 1969 the hedges around the skylights were removed.

- Reestablish the low-growing evergreen hedges around each of the three smaller skylights east of the Bathhouse. Appropriate species include plants similar in character to African boxwood (*Myrsine africana*), English boxwood (*Buxus sempervirens*), Japanese boxwood (*B. macrophylla japonica* 'Green Beauty'), and Japanese holly (*Ilex crenata*).
  - Align new plant materials for the hedge to generally follow the square interior structure of the skylights, but maintain the outside line of the hedge in a circular form
  - Prune the hedge as needed to maintain a height of 18-30 inches (approximate historic height).
  - Space hedge plantings to permit access for maintenance.
- Reestablish the hedges on three sides of the large skylights. Maintain the hedges at a height of 18-30 inches. (Figure 115)

Figure 115. Planting Concepts, East Bleachers and Skylights

Cultural Landscape Report: Aquatic Park  
San Francisco Maritime  
National Historical Park  
2010

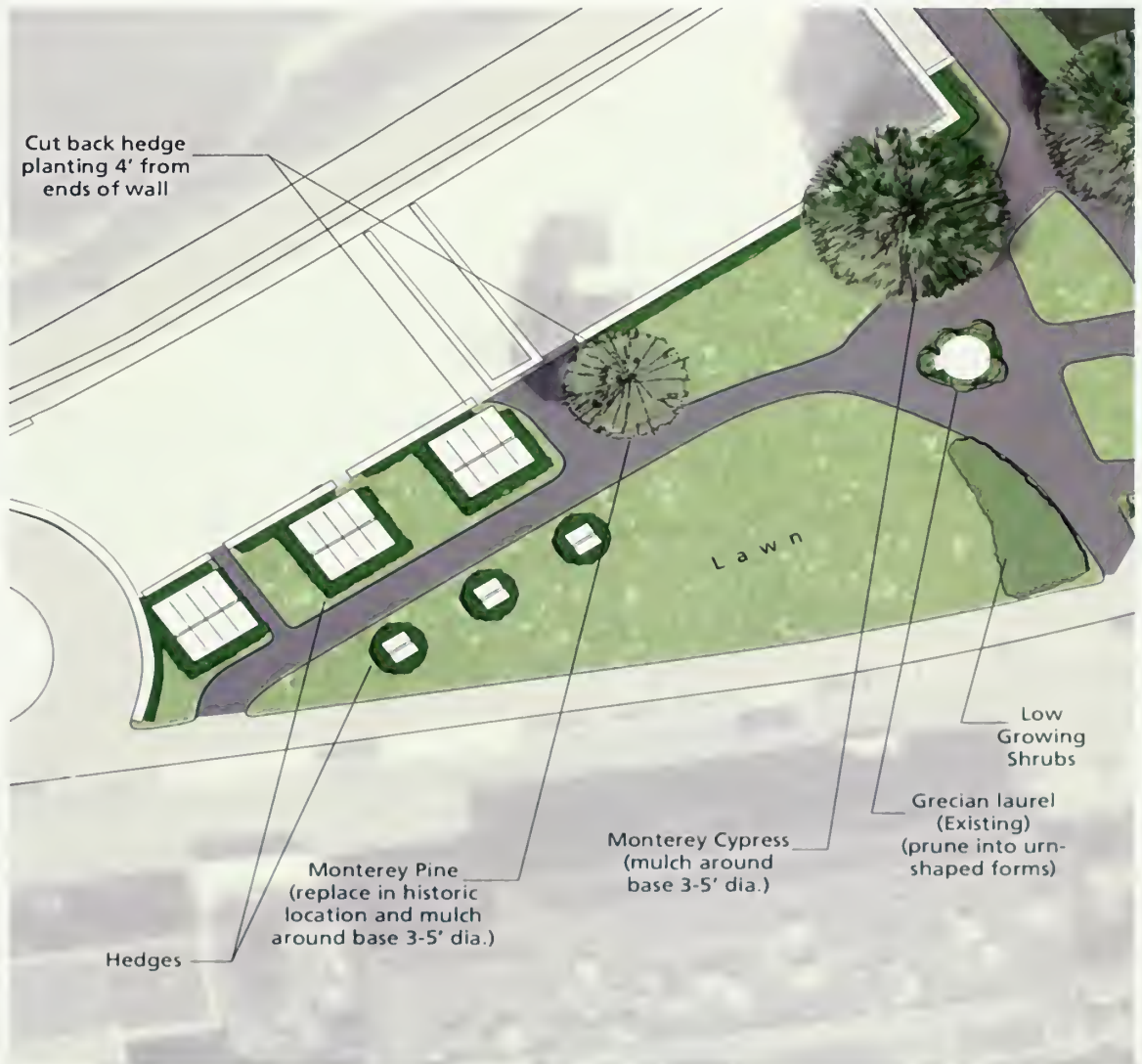

- Retain the use of rails or similar safety features around the skylights until the hedges become established. Remove railings after hedges are established and form a continuous barrier around the skylights.
- Coordinate with historical architect to ensure that plantings do not impair the water barrier system installed as part of the bleacher rehabilitation.

## Trees

A small number of trees were planted in Aquatic Park during the period of significance. In general, trees were used sparingly and strategically to complement the simple design aesthetic. Based on aerial and historic photographs it appears that trees planted during the period of significance included the Monterey cypress (*Cupressus macrocarpa*) and Monterey pine (*Pinus radiata*) at the top of the East Bleachers, a Monterey pine near the Sea Scouts building (no longer extant), and the London plane (*Platanus acerifolia*) trees on Van Ness Avenue.

The Monterey cypress at the southeast corner of the East Bleachers, as well as the Monterey pine that was removed from the back of the bleachers, appear to have been in place at least by 1948. The growth habit associated with these tree species is in keeping with the modern aesthetic that characterizes the park.

The two Monterey pines on the northeast slope along the edge of the East Bleachers were planted as part of the development of Victorian Park. Originally, this area was more open and planted with smaller shrubs or a hedge that wrapped around from above the bleachers. A photograph from the early 1940s shows five upright shrubs 3-4 feet tall between the corner of the bleachers and the bleachers' door. The area from the door to the northeast corner of the bleachers is obscured in the photograph and may also be planted with these shrubs. These may have been of the same plant as the hedge or of a different, but similar, material.

The Monterey cypress that is east of the bleachers within Victorian Park was also planted as part of the development in the 1960s. Although it is compatible with the character of the historic designed landscape of Aquatic Park, it is not historic. (Figure 116)

## Treatment Recommendations

- Preserve and maintain the historic Monterey cypress tree (*Cupressus macrocarpa*) located on the south side of the East Bleachers. If the tree cannot be saved as a result of the rehabilitation project, replace the tree in kind.
- Retain the easternmost Monterey cypress tree located on the edge of the walkway between Aquatic Park and Victorian Park.
  - When the tree fails it should not be replaced. The area where the tree is should be replaced with low-growing shrubs or lawn as discussed in the Victorian Park treatment section of this CLR.
- Conduct additional research prior to restoring the tree located near the Sea Scout building. Research to date has not revealed the role of this individual tree in the overall park design. Additional research might focus on both the significance of the tree during the historic period, the value to the contemporary park user, and the suitability of placing a relatively large tree in a location where it may adversely affect structural components of the seawall and extended infrastructure.
- Replant a Monterey pine (*Pinus radiate*) closer to the site of the original pine, depicted in historic photographs.
- Provide a mulch bed around the trunk of the tree and install metal edging between the mulch and other materials to retain the bed and create a distinct edge.
- Preserve and maintain the existing London plane trees (*Platanus acerifolia*) planted along the Van Ness Avenue extension.
  - Replace missing London plane trees (*Platanus acerifolia*) in kind to fill in gaps as appropriate.
  - Replace existing trees in kind if they fail.
- Remove the non-historic hawthorn tree at the west end of the core area near Van Ness Avenue and the Upper Promenade.



**Figure 116** Planted in the 1960s during development of Victorian Park this Monterey cypress tree on the east side of the park is not historic, but is compatible with the character of the park. (NPS, 2008).



- Remove pines (*Pinus* sp.) along the top of retaining wall west of the Bocce Ball Courts as recommended in the *Tree Assessment and Risk Management* report for Aquatic Park (2007). These trees are not historic and should not be replaced.
- Do not establish any new trees within the Core Area unless replacing historic trees as defined in this report.
- Incorporate maintenance of trees into a preservation maintenance program through FMSS to address appropriate arboriculture practices to retain the health and vigor of individual trees.
- Monitor and assess the condition of trees to determine hazard potential.

## Bathhouse Plantings

During the historic period ornamental plantings were used in front of the Bathhouse, along Beach Street, and along the north side of the building, facing the cove. In front, two planting beds extended along the foundation of the building on each side of the entrance. (Figure 117) While plantings within the beds changed at least once during the historic period, the character of the beds remained the same. By the mid 1940s each bed was composed of four tall, upright shrubs with an open form planted between the round porthole windows. Below these, shrubs were planted in a continuous row. A low hedge, not more than 18 inches high, lined the sidewalk in front of the shrubs. These beds

**Figure 117.** View of the Bathhouse from the hill north of Beach Street, showing the vegetation and character of plantings across the front façade of the building. View looking northeast, ca. 1940. (*San Francisco Maritime NHP, Historic Documents, Photograph Collection, P81-073,2n*)



were generally maintained to be formal in character with clipped edges and symmetry that reflects the architectural forms of the building. Since the historic period these beds have been removed and paved over with asphalt.

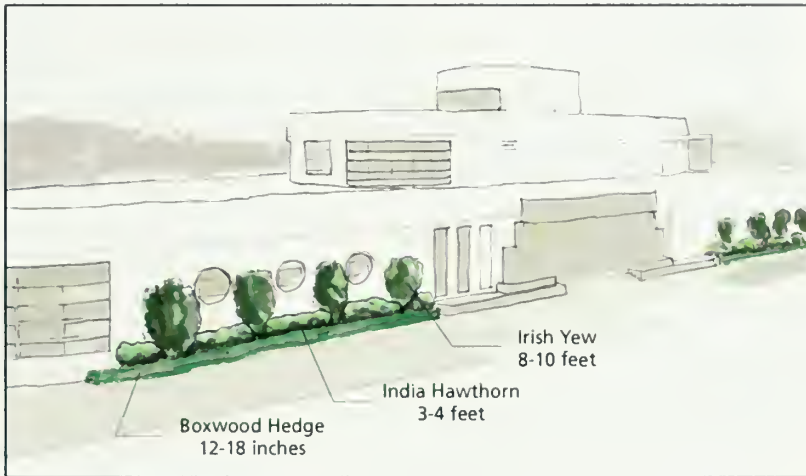

**Figure 118** Treatment recommendations for plantings in front of the Bathhouse encourage restoration of non-extant planting beds and materials.

## Treatment Recommendations

- Restore planting beds in front of the Bathhouse along the Beach Street sidewalk. (Figure 118)
  - Undertake restoration in conjunction with general rehabilitation of the façade, fountains, utility infrastructure, and removal of asphalt walkways along Beach Street.
  - Design planting beds to extend on each side of the building entrance from the end of the fountain to the end of the building.
  - Establish plants in each planter as follows
    - i. Four tall (8-10 feet) open-form shrubs such as *Taxus baccata* 'stricta' or similar.
    - ii. A grouping of flowering shrub (3-5 feet tall) such as *Raphiolepis indica* or similar.
    - iii. A low-growing hedge (12-18 inches in height) such as *Buxus microphylla japonica* or similar.

**Figure 119.** Historic view of the north side of the Bathhouse showing the placement of juniper plants in the planters along the foundation of the building. View looking southwest, n.d. (Courtesy of the San Francisco History Center, San Francisco Public Library AAA 6748)



On the north side of the Bathhouse, individual shrubs were planted in small planters between each set of windows. (Figure 119) Eight semicircular planters each contained one juniper shrub, maintained in an upright, irregular conical form. A longer bed was located at each end of the building. There is no indication that these planters ever contained more than a single shrub each. Today, six of the original eight junipers remain in the planters near the building; two of the junipers have been removed and their planters paved over with concrete. The long planting bed on the west end of the Bathhouse contains hebe shrubs, while the bed on the east side is empty. It is unknown if this material was used historically, but it is compatible with the historic design. Today the junipers appear in poor condition from either a lack of light in the shade of the building, or a lack of water due to the small planters and overhanging structure.

**Figure 120.** View of the existing juniper plants on the north side of the Bathhouse. View looking south east. (NPS, 2008)



Also on the north side of the Bathhouse are two, low median planting beds. (Figure 120) These beds are approximately 6-inches high and defined by a concrete curb. During the historic period, these beds contained vegetation, although the historical record is insufficient to determine the specific plant materials. Historic photos suggest that the planting beds may have contained very low shrubs or a low hedge around the edge of the beds, with lawn or groundcover in the center. Today the beds do not contain any vegetation.

- Maintain the junipers in good condition in their present location. Enhance irrigation and pruning to maintain plant health. If the junipers cannot be maintained in good condition in their present location, they should be replaced with a species that has a similar form and character but that will better tolerate the conditions of the location, such as *Chamaecyparis obtusa* or similar. (Figure 121)

Figure 121. Planting Concepts, Bathhouse

Cultural Landscape Report: Aquatic Park  
San Francisco Maritime  
National Historical Park  
2010

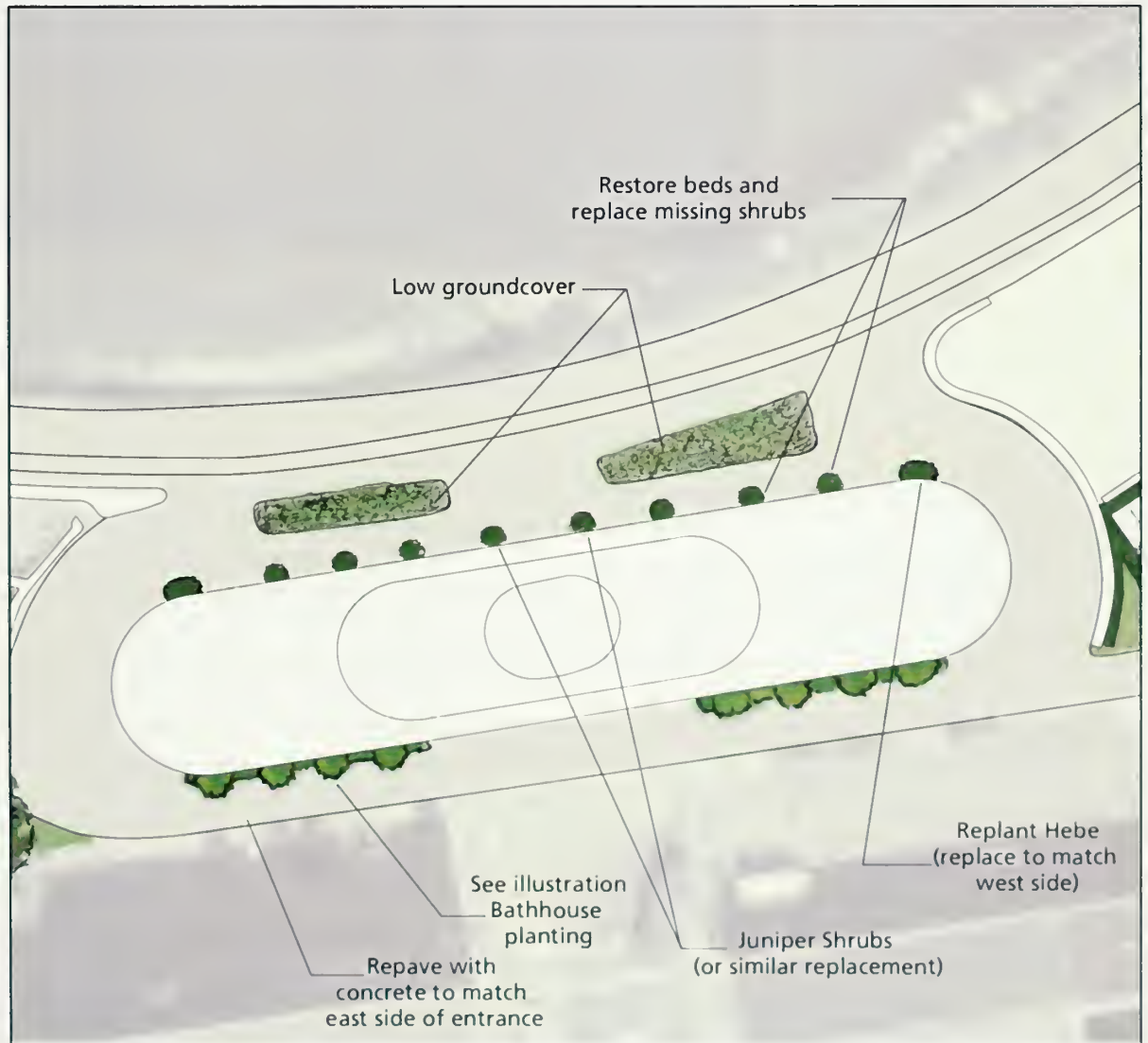



- Restore the two missing planters on the north side of the building to reinforce the symmetry of the planting. Retain the hebe in the westernmost bed or replace with a similar shrub. Plant a matching shrub in the bed at the eastern end of the building.
- Plant eight shrubs in planters along the north side of the building. The long bed on the east end of the building should contain a shrub that matches the one on the west end. This may be accomplished either by planting a hebe to match the existing one on the west end, or by replacing the hebe and planting matching shrubs in both planters.
- Plant the two low planter medians on the north side of the Bathhouse with a suitable low-growing groundcover similar in character to *Rosemarinus* or *Juniperus sp.*

## Pocket Park

As noted on the 1936 site plan for Aquatic Park, the small area on the west side of Van Ness Avenue, referred to as the “pocket park”, was originally intended to be part of the design for the park. However, this small area remained undeveloped and unused until many years later. Based on historic images from the 1940s, the area west of Van Ness appears to have been used for parking or storage associated with the structures located on top of the hill in Fort Mason. A structure, probably a garage or maintenance shed, is visible in aerial photos from the late 1940s and early 1950s. Through the early 1970s the area does not appear to have served a specific function and was vacant at times. In 1976 the NPS designed and installed a semi-circular, brick-paved seating area with benches, and planted a lawn and several ornamental trees and shrubs. The benches were removed in 2008.

Pumping Station No. 2 on the north end of the Pocket Park is maintained by the City of San Francisco Fire Department. This station is part of the city’s auxiliary water supply system. A planting bed along the east foundation of the building is maintained by the park, but is not addressed in this report. (Figure 122)



**Figure 122** Several structures associated with the 1970 development of Pocket Park were removed in 2008 including the benches pictured here. Recommendations encourage additional rehabilitation to a more compatible setting adjacent to Aquatic Park (NPS, 2008)

## Treatment Recommendations

- Remove incompatible components of the pocket park including:
  - The brick paving and timber benches located in the pocket park. Replace with lawn.
  - The pine trees and fig trees currently growing into the allée of London plane trees.
  - The berms and contrived landforms.
- The missing portions of the sidewalk on the west side of Van Ness Avenue.
- Retain existing trees in the pocket park for shade. When they die or become hazard trees, they should not be replaced.
- Preserve the historic character of the street by protecting and maintaining the historic features, including the street lamps, concrete street surface, and London plane trees (*Platanus acerifolia*).
  - Preserve concrete streetlamp posts. Repair when necessary using compatible materials and techniques.

- Work in collaboration with Golden Gate National Recreation Area to stabilize the historic features on the slope above the park in conjunction with the rehabilitation of the Fort Mason gardens.

## Small-scale Features

Over the years a variety of small-scale features such as benches, bike racks, light fixtures, garbage cans, stair railings, wayfinding and directional signs, fountains, and commemorative plaques and objects have been added to the park landscape. In some cases these features are sited based on operational needs and reflect a variety of styles that are not always visually compatible. Individually these features may be functional or commemorative, but in all cases the aggregate effect of such a disparate collection of furnishings and objects tends to detract from the simple lines and uncluttered design character associated with the Streamline Moderne style. Recommendations for small-scale features address existing objects and the general character, type, location, and materials for new site features that accomplish operational requirements and are compatible with *The Secretary of the Interior Standards and Guidelines for the Treatment of Historic Properties*. (Also see the section, Recommendations for “Structures,” and “Circulation”)

**Figure 123.** Historic lampposts remain in Aquatic Park along the Beach Promenade and Municipal Pier. (NPS, 2007).



## Treatment Recommendations

- Preserve and maintain small-scale historic site features that contribute to the character of the NHL District.
  - Retain and repair as needed historic lampposts located along the Beach Promenade and in other areas throughout the park. (Figure 123)
  - Repair and reestablish as possible, the historic drainage features including grates and manhole covers.
  - Ensure that the historic basalt block curbing located along walkways is preserved and maintained in kind through the Facility Maintenance Software system (FMSS).
  - Document the historic small-scale features such as benches and light standards on Municipal Pier. Consider restoration of these features in the future rehabilitation and/or reconstruction of the structure.



- Consider removing and replacing incompatible site furniture and contemporary small-scale features located throughout the park such as drinking fountains, benches, garbage cans, and bike racks. (Figure 124 a,b,&c)
  - Cluster utilitarian site elements such as garbage cans and benches whenever possible to reduce site clutter.
  - Assure that building utilities and associated infrastructure such as cooling systems, water lines, and electrical panels are located in a manner that reduces visual impacts and potential adverse affects to the historic designed landscape.
  
- Conduct an inventory of small-scale features and work with park curators and historians to evaluate the historical significance of maritime-related objects and features displayed throughout the park.
  - Undertake appropriate conservation activities to ensure preservation of significant objects.
  - Reassess the location of maritime features to ensure that they are sited in a way that enhances the interpretive environment of the park, and are located where they are not subject to damaging environmental conditions or vandalism.
  - Conduct an inventory and assess the condition of commemorative plaques and structures located in the NHL District. (Figure 125 a&b)
  - Maintain existing commemorative plaques in good condition. Undertake conservation measures as needed and in consultation with park cultural resources staff to ensure appropriate preservation.



**Figure 124 a,b,&c** When viewed collectively, the various styles and materials used for site furniture and utilitarian features in Aquatic Park is not compatible with the historic character of the park. Recommendations encourage a design for these features that is more sympathetic to the historic character and applied consistently throughout the park. (NPS 2007)

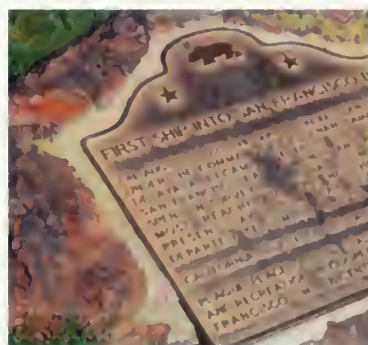

**Figure 125 a&b** Several plaques and markers located in Aquatic Park commemorate significant events associated with the maritime history of the city. (NPS, 2008)





**Figure 126.** Placed at a height that allows cyclists to see it, this sign clearly denotes directional information as a way to reduce potential conflicts between bicycles and pedestrians, and is a useful model, compatible with standards for the NPS messaging system. (NPS, 2007)

- Evaluate the addition of new commemorative plaques and structures within the NHL District as a potential adverse effect. Mitigation may include identifying alternative sites for these features such as Victorian Park (non-contributing area), or locations outside of the NHL District boundary.
- The addition of new signs within the NHL District is generally discouraged with the exception of safety, wayfinding, and interpretive signs.
  - Assure that materials for new signs are compatible with the Streamlined Moderne style. The use of a contemporary and consistent design vocabulary for all signs is encouraged. (Figure 126)
  - Consider the placement of new signs based on the park sign plan, ensuring that all new signs are visually unobtrusive within the historic designed landscape. Whenever possible, consider placing the fewest number of new signs and exhibits in the park as a way to mitigate the aggregate and adverse affects of adding a number of new elements in the NHL District.

## Victorian Park

Victorian Park is located on the east side of Aquatic Park and is defined by Jefferson Street on the north, Hyde Street on the east, and Beach Street on the south. The boundary between Aquatic Park and Victorian Park is defined by a walkway that extends from the Beach Promenade along the east side of the East Bleachers, up to Beach Street. Victorian Park includes the cable car system (a National Historic Landmark), a large pedestrian plaza, lawn, and a number of ornamental plantings.

When Aquatic Park was constructed, the lot east of Larkin Street was vacant and used as a construction yard and headquarters for the WPA project. Although the lot was not part of the original design for Aquatic Park, the city considered it part of the site and reserved it for future development.

During the 1950s the waterfront at Aquatic Park was emerging as a stage for the interpretation of San Francisco's maritime history. The Bathhouse was converted into the San Francisco Maritime Museum and several historic vessels were moored at the Hyde Street Pier. Karl Kortum, the founder of the San Francisco Maritime Museum and the leading creative force behind what would become Victorian Park, envisioned the new park as an entry point and connection between the Maritime Museum and pier. Led by Kortum, the Maritime Museum blocked the sale of the site for an apartment building in 1955 and campaigned for the establishment of the State Historical Monument at the site. When Kortum "rejected" the first plan for the site because of its "poor detailing", he was invited to provide another plan. Landscape Architect Thomas Church worked with Kortum on the new design which eventually included a defined geometry, a simple understated plant palette, and furnishings that were stylistically Victorian in character.

The 1961 plan for Victorian Park featured two terraces and a cross-axis along the south and east edges of the block. Repeating circular forms along the axis mirrored the cable car turnaround and functioned as the fulcrum of the axis. The east-west axis extended the length of the upper terrace and included the cable car turnaround, a broad plaza with a center divide, an allée of small trees, and Victorian-style benches. This upper terrace was geometrical and ornamental in character, with a number of diverse and colorful plant species, including *Agaphanthus*, *Pelargonium*, *Vinca*,

and *Fragaria*. Below the upper plaza, the landscape was more simple and modern in character. A large planting bed with juniper shrubs covered the slope north of the cable car turnaround and below the planting bed, where an expansive area of lawn extended down to the street.

Today conditions in Victorian Park reflect a mixture of elements from the original 1961 design, components from a 1982 construction project focusing on re-configuration of the cable car turnaround, and incremental changes that have occurred in the park since then. Because Victorian Park was not part of the original design for Aquatic Park and does not contribute to the NHL district, recommendations in this report do not advocate restoration of the landscape to a specific historic period. Rather, treatment reinforces the original site plan for Victorian Park to the degree it continues to provide a distinct but compatible character with Aquatic Park.

Recommendations for Victorian Park also address strategies to mitigate ongoing maintenance issues and impacts to park resources resulting from years of intense and concentrated public use of the park. Large numbers of visitors, especially in the areas around the upper plaza, create severe wear on park features and heavily impact vegetation along Beach Street and throughout the upper plaza. While mitigation strategies include short-term and long-term measures, the majority of recommendations focus on the use of alternative plant materials to reduce maintenance, and improvements to circulation using compatible fencing to redirect pedestrian traffic.

The goals of landscape treatment for Victorian Park are to promote a safe and pleasant visitor experience, and within the framework of the original design, to redevelop plantings and circulation in the park in a manner that can be maintained in good condition.<sup>7</sup>

Finally, although Victorian Park is not historically significant, it is within the NHL district boundary. In this regard, prior to implementation of any recommendation in this report, additional compliance and review is recommended in order to evaluate the aggregate effect of the changes on the integrity of the district.

The treatment recommendations for Victorian Park are organized into categories of vegetation, circulation, and small-scale features.

## Vegetation

### Upper Plaza

The 1961 planting plan for Victorian Park identified several ornamental shrubs, perennials, and groundcovers for the upper plaza. Planting beds along Beach Street sidewalk were planted with layered rows of *Chamaecyparis*, *Agapanthus*, and *Pelargonium*, with Chilean mayten trees (*Maytenus boaria*) along the center, and *Juniperus* sp. planted on the corners. This planting created a relatively lush border between the park and the street that, including the height of the raised bed, was approximately 4 feet high. Within the plaza, an allée of small, tree-form *Pittosporum* were planted on each side of the plaza, with wild strawberry planted in the low central divider. The overall result was a generally open plaza with open views north over the broad sloping bed of low-growing juniper and lawn to the bay.

Today the center divider is planted with a variety of perennials and shrubs that visually divides the plaza in two. Mixed perennials have replaced the juniper shrubs in the bed below the plaza. *Agapanthus* now dominates the plantings along Beach Street, but cherry trees have replaced the Chilean maytens (*Maytenus boaria*).

The primary issue with all vegetation in the upper plaza is the degree to which it can be maintained in good condition. Currently large numbers of people affect the planting beds in the upper plaza by creating social trails and shortcuts, trampling plants, and compacting the soil. Substantial amounts of trash and debris collect between plants in the beds and dead flower and seed stalks, and annual die back create an unkempt look. The wide variety of species adds to a wild appearance, and fast-growing species often require severe pruning to keep them from outgrowing the space.

To create a better environment for managing the large numbers of visitors in the upper plaza that is still compatible with the intent of the 1961 plan, treatment focuses on establishing low-stature plant materials and installing low fencing and new paving to redirect visitors and reduce impacts.



**Figure 127.** Using funds from a First Bloom grant, the park worked with Boys and Girls clubs in the city to replant the planting bed in the center of the Victorian Park pedestrian plaza. The grant program emphasizes the opportunity to engage urban youth in garden projects where they can learn about the use of native plants in the landscape. (NPS, 2010)



## Treatment Recommendations

- Remove plants currently in the planter down the center of the plaza and replace with low-growing materials and ground cover similar in character to *Juniperus*, *Cistus*, *Lantana*, Rosemary, *Hebe*, *Santolina*, and *Pelargonium*.
  - Consider installing a low profile (22 inches high) post-and-chain barrier around the plant beds to prevent pedestrian shortcuts and social trails through the beds.
- Plant low-growing shrubs, groundcover, or turf in the raised beds along Beach Street to improve overall conditions that result from the inappropriate use of these areas by the public. (Figure 127)

## Lawn Area

In the original design for Victorian Park, the area below the upper plaza had a very different landscape character from the relatively “busy” upper plaza. A large area of lawn and a uniform planting of shrubs, massed in a planting bed north of the cable car turnaround, presented a landscape character more similar to Aquatic Park. In this way the lower area of Victorian Park created a distinct, but compatible transition to Aquatic Park. Victorian furnishings such as benches and light standards were used throughout the lower area of the park, but were few in number. Also absent from the lower terrace were the showy beds and perennial borders that characterized the upper plaza. In many ways this change in character from a more decorative Victorian aesthetic to a more subdued

modern one supported an appropriate thematic transition between the city and Aquatic Park.

Today juniper plantings have been replaced with a variety of perennials, presenting significant maintenance issues similar to those of the upper plaza. Recommendations address mitigation of visitor impacts, and establishment of a more sustainable plant palette.

## Treatment Recommendations

- Maintain lawns throughout the lower portion of Victorian Park in good condition.
- Mitigate impacts from visitor short-cutting through the planting bed on the north side of plaza. Alternative treatments for this area may include:
  - Remove existing plant materials and replant with turf grass.
  - Remove plant materials and replace with narrow band of cobblestones to the edge for the plaza.
  - Replace existing plant materials with materials similar to those used in the upper plaza, such as *Juniperus spp.*, *Cistus*, *Lantana*, Rosemary, *Hebe*, *Santolina*, and *Pelargonium*. Use a low-profile fence to prevent pedestrian circulation through the bed.
- Re-configure the planting bed located below the cable car turnaround.
  - Remove planting bed on slope north of the cable car turnaround and construct a retaining wall to create a nearly level terrace below.
  - Re-grade into stepped terraces and plant turf grass.
- Remove the existing materials in the planting areas around seating areas, and replace with low-growing shrubs similar in character to *Juniperus spp.*, *Cistus*, *Lantana*, Rosemary, *Hebe*, *Santolina*, and *Pelargonium* used in other areas of the park.
- Retain the *Arbutus marma* trees along Jefferson Street.

## Cable Car Turnaround

In 1982 the cable car turnaround was re-configured. The cars originally entered the park from Hyde Street in line with the upper plaza. The circular form of the turnaround enforced a formal theme that was repeated in the waiting area and circular beds and fountain at the west end of the plaza. In 1982 the turnaround was moved north, and cable cars entered the turnaround on a diagonal from the southwest corner of the park. This modification not only disrupted the dominant axial layout of the park, it also significantly changed the grade around the turnaround. Moving the turnaround north required additional fill, creating a steep bank down into the lower area of the park. This fill bank was planted with perennials and shrubs. A hedge at the top of the slope created the back of a seating wall associated with the cable car turnaround. On the upper terrace, on either side of the turnaround, 12 *Metrosideros* trees were planted in three gridded clusters of four trees each.

Recommendations for replanting the sloping bed north of the cable car turnaround are found above.

## Treatment Recommendations

- Retain Escallonia hedge around the turnaround. Feather-prune to maintain height, allowing views to the bay.
- Retain the *Metrosideros* trees. These trees are relatively deep-rooted.
- Retain the Friedel Klussman tree and plaque.

## Northeast Corner of Victorian Park

Prior to construction of Victorian Park, a city pumping station was located in the northeast corner of the lot. During initial development, the structure was incorporated in the design, and as a result, vegetation in this corner was established primarily for the purpose of screening the structure. Five *Araucaria* trees around the structures, with shrubs and groundcover filling in, completed the screen. When the pumping station was removed an NPS sign for San Francisco Maritime National Historical Park was placed in this location. The park sign now sits in a raised planting bed with ornamental grasses and low flowering plants surrounding it.

## Treatment Recommendations

- Retain the *Araucaria* trees until they become hazards or fail. Do not replace. Establish lawn in place of the trees.
- Maintain the grass in good condition.
- Remove existing plantings around NPS entrance sign for San Francisco Maritime National Historical Park. Replant with low-growing perennials and seasonal annuals to provide color and an ornamental setting for the sign.

## Circulation

The circulation system designed for Victorian Park established a formal framework for the park. Originally the primary walkways consisted of two dominate cross-axis intersecting at the cable car turnaround. The east-west axis comprised the upper plaza—a broad, double promenade divided with a median and planted with a row of *Pittosporum* trees down the middle of each side. Victorian style benches lined the plaza. The plaza was anchored on each end by circular forms—the cable car turnaround and the waiting shelter on the east end, and the circular beds and fountain on the west end. The low groundcover in the median allowed open views to the Bathhouse, East Speaker Tower, and other features of Aquatic Park. This was an important aspect of a design intended to make a connection between the Maritime Museum in the Bathhouse and the historic vessels at the Hyde Street Pier.

The north-south axis consisted of a walkway that descended three flights of stairs from the cable car turnaround to Jefferson Street on the north edge of the park. From there visitors could reach the Hyde Street Pier. A number of sweeping walkways across the lower part of the park comprised the balance of the circulation system of Victorian Park.

Historically, the majority of the walkways in the park were surfaced with crushed gravel. Cobblestone was placed under the benches in the plaza and in the lower seating areas. The area around the cable



car turnaround was concrete with cobblestone borders. The crushed gravel has since been replaced with asphalt, but the cobblestone borders remain. In the redesign of the cable car turnaround, the surface of the plaza around the turnaround was paved with interlocking concrete paving blocks.

## Treatment Recommendations

- Retain the current layout of all circulation features.
- Retain the current surface of the upper plaza and park pathways, and maintain in good condition. When patching becomes excessive, re-pave the pathways with new asphalt.
- Retain the extent and surface elevation of all new paving or asphalt patching. Ensure that features such as concrete curbs and cobblestones are not covered or otherwise damaged when resurfacing.
- Retain and maintain in good condition the cobblestone borders under the benches. Re-position any displaced blocks and replace any missing blocks with compatible materials and workmanship.
- Consider reducing hazards by replacing the concrete block paving in the plaza around the cable car turnaround with concrete.
- Re-grade and reset pavers in turnaround when roots displace.

## Small-Scale Features

Most of the site furniture and small-scale features in Victorian Park were identified, designed, and crafted by Karl Kortum, park designers, and craftspeople. Furnishings include more than 40 benches, gas lamp standards, tree well grates and tree guards, decorative railings, bollards, and a water structure with three levels (humans, horses, and dogs). These features, to a high degree, define and imprint the Victorian character of the park, establishing an identity apart from Aquatic Park.

# Victorian Park Treatment Plan (Schematic)

Figure 128

## Sources

1948 Aerial Photograph Aquatic Park, Historic Documents, Historic Photograph Collection, San Francisco Maritime National Historical Park; 2005 Aerial Photograph, Pacific Aerial Survey

## Notes

Symbols and locations for plant materials are schematic and should be interpreted in conjunction with the written recommendations.

Remove juniper and plant with perennials and low growing shrubs.

Araucaria (Existing)



## Cultural Landscape Report: Aquatic Park

San Francisco Maritime  
National Historical Park  
2010

National Park Service  
Pacific West Region  
Cultural Landscape Program



# Victorian Park Treatment Plan (Schematic)

Figure 128

## Sources

1948 Aerial Photograph Aquatic Park, Historic Documents, Historic Photograph Collection, San Francisco Maritime National Historical Park; 2005 Aerial Photograph, Pacific Aerial Survey

## Notes

Symbols and locations for plant materials are schematic and should be interpreted in conjunction with the written recommendations.

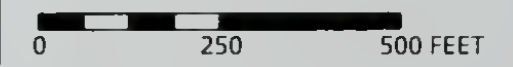
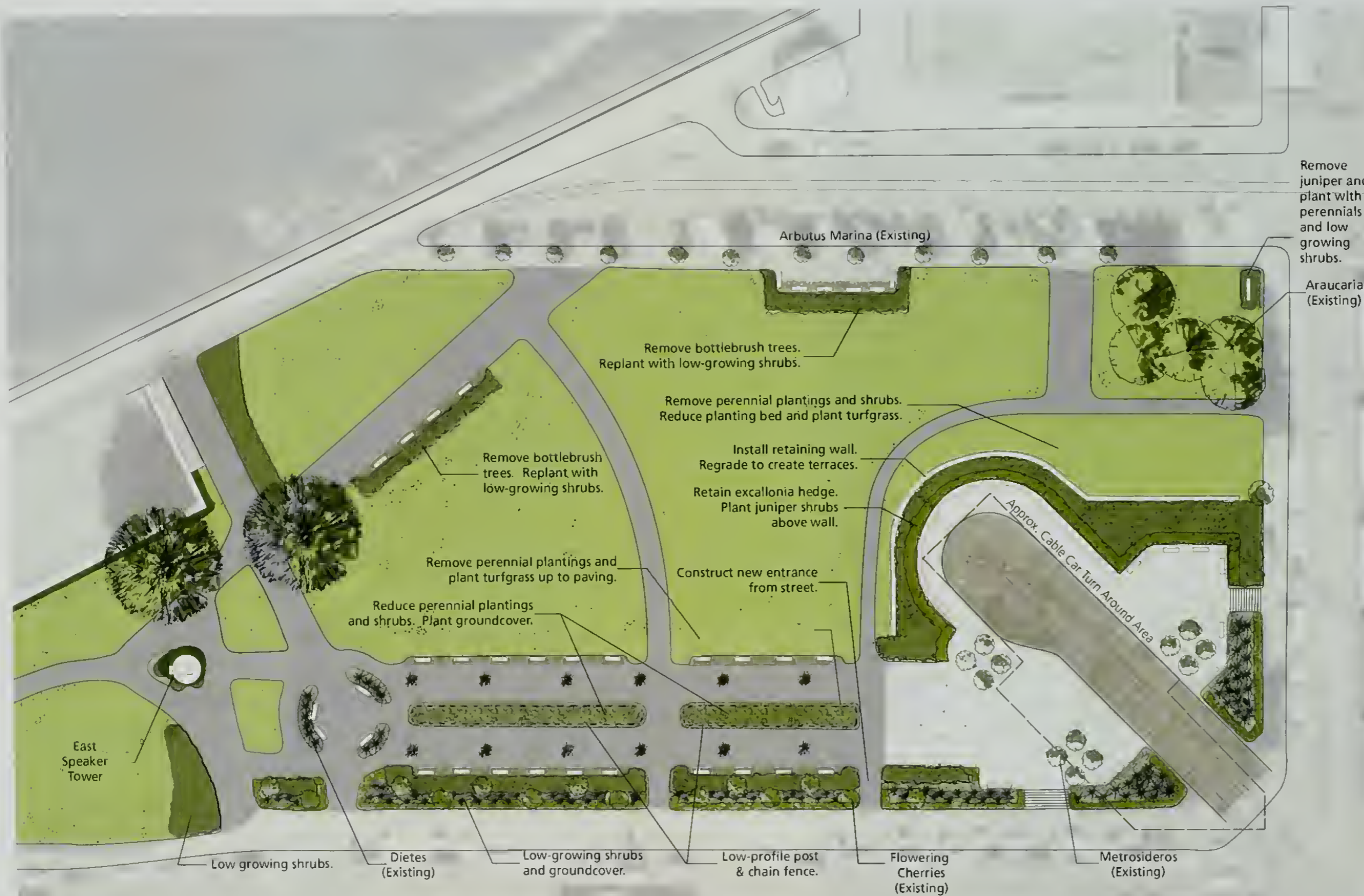

Cultural Landscape Report:  
Aquatic Park

San Francisco Maritime  
National Historical Park  
2010

National Park Service  
Pacific West Region  
Cultural Landscape Program





## Treatment Recommendations

- Retain original (1961) site furnishings, including benches, gas lamp standards, tree grates, railings, bollards, and the fountain. Maintain furnishings in good condition.

## Bocce Ball Courts

Although the southwest corner of what is today Aquatic Park was not part of the original site construction by the WPA, the area has been used as a recreational area nearly as long as the park has been in place. Through the end of the 1930s the Spring Valley Water Company pumping station was located here. Historic photographs taken during construction of Aquatic Park in 1938 show the pumping station, but by 1942, it no longer appears in historic images.

Treatment recommendations for the Bocce Ball Court area are presented to provide flexibility related to appropriate implementation and future new development in this area. Like the pocket park area, and in some way, Victorian Park, this area of Aquatic Park was considered part of the overall development that never came to fruition. It is within the NHL district but is non-contributing. Recommendations target enhancing compatible design while maintaining current use and function.

## Treatment Recommendations

- Remove planting beds and timber bed structures on the north and west sides of the courts.
  - Plant turf grass in the north planting bed.
  - Re-grade to meet the grade of the existing lawn.
  - Re-surface the area of the former planting bed on the east side of the courts with gravel.
- Remove trees and laurels along the west side of the courts below the large retaining wall.
- Retain bottlebrush trees and poplar trees
- Extend existing *Escallonia* hedge along Upper Promenade (see Recommendations, Core Area, “Vegetation”).



## Endnotes

### Treatment

1 The identification of 10 historic structures in Aquatic Park is only referencing the primary buildings, the pier, and significant retaining walls. The NPS List of Classified Structures (LCS) for San Francisco Maritime National Historical Park lists 28 structures. The LCS includes all structures in the park including historic vessels and circulation features that are listed or eligible for the National Register of Historic Places. Recommendations for circulation features in Aquatic Park are described in the section on recommendations for circulation, found below.

2 This recommendation is made to promote rehabilitation of the Streamlined Moderne aesthetic of an important circulation feature in the park, and to enhance the architectural character of the Bathhouse façade. Although the documentation suggests that during the historic period paving on the east side of the Bathhouse was either asphalt or oiled gravel, it appears that the current asphalt paving may have been laid over another surface material and is not historic. In any case, the recommendation to resurface this area with concrete is made for three reasons; 1) concrete was historically used on the other promenades and is a material associated with the Streamlined Moderne style and design aesthetic; 2) the front façade of the Bathhouse merits a more symmetrical formality compatible with the building style; and 3) the use of concrete is more sustainable.

3 The reason for replacing the planting bed with lawn is not documented.

4 The Grecian laurel in the planting beds around the speaker towers may be the exception. In every available historic photograph they appear to be pruned into a vase-shaped form, relatively tall, and wider at the top than the bottom. This has the effect of echoing the form of the speaker tower and adding scale to the structure.

5 A photograph from the early 1940s clearly shows the hedge extending above the wall behind the bleachers and descending the steep slope to the southeast corner. Along the northeast wall, five shrubs appear recently planted. From the location and spacing of these shrubs, it appears that the intent of the planting was to extend the hedge along the wall.

6 Information that might clarify the identification of individual plant species in these beds has not been located, but historic photographs clearly show the general growth and character of the plantings. Suggestions for species are made based on these photographs as a basis for reestablishing historic character

7 It is beyond the scope of this CLR to provide a complete design for redevelopment of Victorian Park. It is recommended that San Francisco Maritime NHP work with its stakeholders to undertake a more holistic and integrated design for Victorian Park, either through a special study or as part of a general planning process.

## SELECTED BIBLIOGRAPHY

Bakewell & Brown. "Plans for Improvement of the Aquatic Park by the Construction of a Recreation Pier." Prepared for the City and County of San Francisco, Board of Park Commissioners.

Bakewell & Brown and John A. Baur, Associated Architects and Frank G. White and Harry E. Squire, Construction Engineers. August 1925. San Francisco Maritime National Historical Park, HDC. 555. Drawer 5.

Bush, Donald J. *The Streamlined Decade*. New York, George Braziller, Inc. 1975.

Canright, Stephen. "The Mythic Foundations of Aquatic Park" in *Sea Letter*, Number 65, 2004: 6-19.

California Department of Natural Resources, Division of Beaches and Parks. "Initial Development Plan, San Francisco Maritime State Historical Monument, Master Plan, Sheet 2 of 6, 1958." San Francisco Maritime National Historical Park, Museum Plans Collections, HDC 555. Drawer B5.

\_\_\_\_\_. "Preliminary Development Plan, Proposed Block 9 Development, San Francisco Maritime State Historical Monument, Sheet 1, 1959." San Francisco Maritime National Historical Park, Museum Plans Collections HDC 555. Drawer B5.

\_\_\_\_\_. "General Development, San Francisco Maritime State Historical Monument, July 1960." San Francisco Maritime National Historical Park, Museum Plans Collections, Karl Kortum Collection. HCD 1084, Box 5, Series 2, Subseries 2, File Unit 37 Victorian Park (Lamps, Benches, Ironwork) 1959-1991.

\_\_\_\_\_. "San Francisco Maritime State Historic Park, September 16, 1964." San Francisco Maritime National Historical Park, Museum Plans Collections SAFR, HDC 555. Drawer B5.

California Department of Public Works, Division of Architecture. "Maritime Plaza (Victorian Park). Sheet 1: Existing Conditions; Sheet 2: Grading Plan; Sheet 3: Drainage and Electrical; Sheet 4: Paving and

Layout; Sheet 5: Gas Lighting Layout; Sheet 6: Sprinkler Irrigation Plan; Sheet 7: Planting Plan; Sheets 8 and 9: Construction Details; Sheet 10: Sprinkler Irrigation Details; Sheet 11: Cable Car Waiting Station. June 1961.” San Francisco Maritime National Historical Park, Museum Plans Collections, HDC 555. Drawer B5-17-2 “Aquatic Park 1961, California Department of Public Works series.”

Church, Thomas D. Letter to Karl Kortum. 10 July 1962. San Francisco Maritime National Historical Park, Museum Plans Collections, Karl Kortum Collection. HCD 1084, Box 5, Series 2, Subseries 2, File Unit 33: Victorian Park Cable Cars – Waiting Room, Klussman Plaque, 1961-65.

City and County of San Francisco Department of Public Works, Bureau of Architecture. “Aquatic Park, Memorial Drinking Fountain, Polk and Beach Streets, San Francisco, California, Plan Elevations and Details. March 24, 1967.” San Francisco Maritime National Historical Park. Museum Plans Collections.

City and County of San Francisco Office of the Board of Park Commissioners. “Aquatic Park, Bath House Building, Plot Plan, 1936-1937, WPA Project No. 2175, Sheet A-0.” San Francisco Maritime National Historical Park, Museum Plans Collections, HDC 555, Folder B5-11-1.

\_\_\_\_\_. “Landscape Plan, Aquatic Park, February 23, 1937.” Prepared Under the Supervision of T. B. Grabow, Assistant Superintendent of Parks. 4 Sheets. San Francisco Maritime National Historical Park, Museum Plans Collections.

\_\_\_\_\_. “Underground Sprinkling System, Aquatic Park. September 19, 1939.” San Francisco Maritime National Historical Park, Museum Plans Collections HDC 555, Folder B5.

\_\_\_\_\_. “Plan of Auto Parking, Bocci [sic] Courts & Path Arrangement, Scheme E, Aquatic Park, [no date].” San Francisco Maritime National Historical Park, Museum Plans Collections HDC 555, Folder B5.

\_\_\_\_\_. “Details of Typical Boccie [sic] Court for Aquatic Park, prepared under supervision of T. M. Grabow, Assistant Superintendent of Parks, [no date].” San Francisco Maritime National

Historical Park, Museum Plans Collections, HDC 555, Folder B5.

\_\_\_\_\_. "General Plan of Auto Parking Area & Park, Aquatic Park, [undated]." San Francisco Maritime National Historical Park, Museum Plans Collections, HDC 555, B5.

\_\_\_\_\_. "General Plan of Auto Parking Area & Park, Aquatic Park, Division of Engineering, Board of Park Commissioners, San Francisco, Aug 27, 1941." San Francisco Maritime National Historical Park, Museum Plans Collections, HDC 555, B5.

City and County of San Francisco Board of Park Commissioners, Division of Engineering. "General Plan of Auto Parking Area & Park, Aquatic Park, 1940. Sheet No. 1." San Francisco Maritime National Historical Park, Museum Plans Collections, HDC 555, B5.

\_\_\_\_\_. "Details of Bocce Courts at Aquatic Park, 1940." San Francisco Maritime National Historical Park, Museum Plans Collections, HDC 555, B5.

\_\_\_\_\_. "Enlarged Working Details for Auto Parking Area and Park at Aquatic Park, 1940. Sheet No. 3." San Francisco Maritime National Historical Park, Museum Plans Collections, HDC 555, B5.

\_\_\_\_\_. "Proposed Drainage System for Auto Parking Area and Park at Aquatic Park, 1940." San Francisco Maritime National Historical Park, Museum Plans Collections, HDC 555, B5.

\_\_\_\_\_. "Plan of Proposed Irrigation System Aquatic Park - W.P.A. Project, 1940." San Francisco Maritime National Historical Park, Museum Plans Collections. HDC 555, B5.

\_\_\_\_\_. "General Plan of Auto Park Area & Park. 27 August 1941," San Francisco Maritime National Historical Park, Museum Plans Collections.

City and County of San Francisco, Board of Supervisors. Proceedings, 1927, 1931.

City and County of San Francisco, Bureau of Engineering. Annual Reports, 1920, 1921-22.



City and County of San Francisco, Department of Public Works, Bureau of Architecture. "Aquatic Park, Memorial Drinking Fountain, Plan Elevations & Details, Sheet A-1, 1967." San Francisco Maritime National Historical Park, Museum Plans Collections, HDC 555, B5.

City and County of San Francisco, Public Utilities Commission, Utilities Engineering Bureau. "Rehabilitation of Cable Car Trackway. Victorian Park Terminal Landscape Plan." Prepared by Michael Painter & Associates, 1982. Golden Gate National Recreation Area.

City and County of San Francisco, Real Estate Department. "Aquatic Park – Maritime Museum Area, San Francisco, Drawing No. 1, 1969." San Francisco Maritime National Historical Park, Museum Plans Collections, HDC 555, B5.

City and County of San Francisco, Recreation and Park Department. "Aquatic Park Lagoon, Soundings Vicinity of Sea Scout Wharf. February 25, 1953." San Francisco Maritime National Historical Park, Museum Plans Collections HDC 555, B5.

Delgado, James P. *Historic Structures Report: Historical Data Section. Pioneers, Politics, Progress and Planning: The Story of San Francisco's Aquatic Park, Draft.* San Francisco, National Park Service, 1981.

\_\_\_\_\_. Aquatic Park, National Register of Historic Places Inventory-Nomination Form, 1981. Revised by Laura Soulliere Harrison, 1986.

Costello Tree Service. *Tree Assessment and Risk Management*. Report prepared for San Francisco Maritime National Historic Park, San Francisco, California, 2007.

Dow, Gerald R. "Bay Fill in San Francisco: A History of Change." Thesis (M.A.), California State University, San Francisco, 1973.

Eckart, Nelson A. "The Water Supply System of San Francisco" in the *Journal of the American Water Works Association*, 32 (May 1940): 751-94.

Halprin, Lawrence. "Schematic plans for the development of the San Francisco Transportation Museum site. 1956." San Francisco Maritime National Historical Park, Museum Plans Collections, HDC 555. Drawer B5, "Aquatic Park – Landscape, Lawrence Halprin 1956."

\_\_\_\_\_. Plans for the San Francisco Transportation Museum site. Sheet 1: Park Layout and Grading Plan; Sheet 2: Details and Irrigation; Sheet 3: Planting Plan. December 1956. San Francisco Maritime National Historical Park, Museum Plans Collections, HDC 555. Drawer B5, "Aquatic Park – Landscape, Lawrence Halprin."

Hoke, Amy and Eliot Foulds. *Cultural Landscape Report for Fort Mason, Golden Gate National Recreation Area, Volume one: Site History, Existing Conditions, and Analysis*. Brookline, National Park Service, 2004.

Kelly, Roger E. *Archeological Resources of Golden Gate National Recreation Area*. San Francisco, National Park Service, 1976.

Kortum, Karl. Letter to Aubrey Neasham, Historian, [California] Division of Beaches and Parks, October 1, 1959. Included in Kortum 1963.

\_\_\_\_\_. Letter to Thomas Church. 3 July 1962. SAFR Karl Kortum Collection. HCD 1084, Box 5, Series 2, Subseries 2, File Unit 36: Victorian Park Landscaping and Accoutrements 1959-1991.

\_\_\_\_\_. "An Eclectic Park Lit By Gaslight." Typewritten manuscript, 1963. San Francisco Maritime National Historical Park, Museum Plans Collections, Karl Kortum Collection. HCD 1084, Box 5, Series 2, Subseries 2, File Unit 36: 36: Victorian Park Landscaping and Accoutrements 1959-1991.

\_\_\_\_\_. "Background of the Victorian Park." Typewritten manuscript, no date. San Francisco Maritime National Historical Park, Museum Plans Collections, Karl Kortum Collection. HCD 1084, Box 5, Series 2, Subseries 2, File Unit 37 (1 of 2): 1959-91.

\_\_\_\_\_. Letter to William M. Roth, 1966. San Francisco Maritime National Historical Park, Museum Plans Collections, Karl Kortum Collection. HCD 1084, Box 5, Series 2, Subseries 2, File Unit 36: Victorian Park Landscaping and Accoutrements 1959-1991.

Langellier, John Phillip and Daniel B. Rosen. *El Presidio De San Francisco, A History Under Spain and Mexico, 1776-1846*. Spokane, Arthur H. Clark Co., 1996.

Martensen, Phoebe Cutler. "How the WPA Transformed San Francisco"

in *Landscape Architecture*, Volume 69 (1979), Number 1, pp. 74-77.

Mieldazis, J. J. "Aquatic Park Investigation." Memo to H. E. Smith from J. J. Mieldazis, 23 October 1939. National Archives, Record Group 69, WPA, Box 902, California File 651.109, Aquatic Park, San Francisco. National Park Service, Pacific West Region Files, Oakland, California.

Mooser, William, Jr. "Report on Progress of the Works Program in San Francisco." San Francisco, Works Progress Administration. January 1938. Prepared by William Mooser, Jr., Branch Manager.

National Park Service. *Draft, General Management Plan, Environmental Impact Statement, San Francisco Maritime National Historical Park California*. National Park Service, 1996.

\_\_\_\_\_. *General Management Plan, San Francisco Maritime National Historical Park*, National Park Service, 1997.

\_\_\_\_\_. Cultural Landscape Inventory, Aquatic Park, San Francisco Maritime National Historical Park, 2001. Revised 2004.

\_\_\_\_\_. List of Classified Structures, Golden Gate National Recreation Area

\_\_\_\_\_. List of Classified Structures, San Francisco Maritime National Historical Park.

\_\_\_\_\_. Annual Report, 1978. Memorandum to the Regional Director, Western Region, National Park Service from the General Superintendent, Golden Gate National Recreation Area.

\_\_\_\_\_. "Bufano Statues at Aquatic Park and lower Fort Mason." Memorandum to the Maritime Unit Manager from the Acting Park Historian, National Park Service, January 2, 1985. National Park Service, Pacific West Region Files, Oakland, California.

\_\_\_\_\_. "Sidewalk Repairs/Tree Replanting, Van Ness Ave. & The Cliff House, Golden Gate National Recreation Area. Sheet 1 of 1. February 1986." Golden Gate National Recreation Area Archives.

San Francisco National Historical Maritime Park Photograph Collection.

Olmsted, Frederick Law. "Preliminary Report in Regard to a Plan of Public Pleasure Grounds for the City of San Francisco." New York: William C. Bryant & Company for Olmsted, Vaux & Company, 1866. Quoted in Cultural Landscape Inventory, Aquatic Park, San Francisco Maritime National Historical Park, 2004.

Pacific Aerial Surveys. Selected Aerial photographs of the Aquatic Park vicinity, 1938-2005. Oakland, California, Pacific Aerial Surveys.

Painter, Michael & Associates. "Schematic Design, Victoria [sic] Park, San Francisco, California. February 11, 1982." Golden Gate National Recreation Area, Office of Resource Management.

Pickelhaupt, Bill. *Images of America: San Francisco's Aquatic Park*. San Francisco, Arcadia Publishing, 2005.

Punnett, John. M., C. E. "Plan of Proposed Aquatic Park San Francisco, California. Prepared for Aquatic Park Committee By John M. Punnett, C. E., 1913, 1920, 1923, 1925, 1928, 1932, 1938." On file, San Francisco Maritime National Historical Park, Museum Plans Collection HDC 555. B5.

\_\_\_\_\_. "Preliminary map of Westwood park (in Sutro Forest), San Francisco: the property of the Residential Development Company of San Francisco." San Francisco: Baldwin & Howell, 1916.

Punnett, Perez & Hutchinson (Civil Engineers). "Board of Park Commissioners Plan of Aquatic Park, San Francisco, California, 1932." San Francisco Maritime National Historical Park, Museum Plans Collections HDC 555, B5.

\_\_\_\_\_. "Plan of Concrete Parapet, Curb & Seat to be constructed on Recreation Pier, Aquatic Park. Prepared for the City and County of San Francisco, Board of Park Commissioners, August 29, 1933." San Francisco Maritime National Historical Park, Museum Plans Collections HDC.555. Drawer B5.

\_\_\_\_\_. "Topographic Survey of Portion of Aquatic Park for Recreation and Park Department San Francisco, California, 1952 and 1956." San Francisco Maritime National Historical Park, Museum Plans Collections HDC 555, B5.



Quesada, George, AIA. "Facilities Development, Bocce Ball Courts Phase II, Southwest Area, Aquatic Park, Beach St. & Van Ness Ave., San Francisco, 3 Sheets." Prepared for Recreation & Park Department, City & County of San Francisco, Approved by Raymond S. Kimbell, General Manager, 1961. San Francisco Maritime National Historical Park, Museum Plans Collections HDC 555, B5.

Sanborn Perris Map Company. Insurance Maps of San Francisco, California, Volume One. New York: Sanborn Perris Map Company, 1899-1950.

San Francisco Chronicle.

January 27, 1942, p. 9. *Death notice for John Punnett*,

August 11, 1969, p. 36. *Services for William Mooser Jr.*

September 14, 2003, *A bit of Rome rolls into Aquatic Park in San Francisco, Local bocce players aim for global glory* by Julian Guthrie.

San Francisco Examiner

March 30, 1938 *Aquatic Park Probe By U.S. Revealed / WPA Inquiry / Family -Contract Link Under Scrutiny.*

January 27, 1942, p. 19. *Death notice for John Punnett.*

San Francisco Public Library, San Francisco Historical Photograph Collection.

Toogood, Anna Coxe. *Historic Resource Study: The Bay Area Community, A Civil History of the Golden Gate National Recreation Area, Volume 2.* Denver, National Park Service, 1980.

United States Engineers Office, San Francisco, California. "Location Plan, Small Boat Mooring, San Francisco Port of Embarkation, Aquatic Park, Fort Mason, California, March 27, 1944, Sheet 1." San Francisco Maritime National Historical Park, Museum Plans Collections HDC.555. Drawer B5.

[United States Army, Fort Mason], Post Engineers Office. Fort Mason, S.F. Calif. Post Map, Revised October 1, 1943.

[United States Army], Office Quartermaster General. Fort Mason, California, Compiled from the latest information. Drawn by D.N. Stone, OQMG, December 1917, revised May 1918. Golden Gate National Recreation Area Archives, Army Plans Collection.

United States Coast Survey. Entrance to San Francisco Bay. From a Triangometrical Survey under the direction of A.D. Bache Superintendent of the Survey of the Coast of the United States. Washington, 1869 San Francisco Peninsula. Washington, 1869.

Watson, Donald. Letter to Thomas Church. 5 July 1962. San Francisco Maritime National Historical Park, Karl Kortum Collection. HCD 1084, Box 5, Series 2, Subseries 2, File Unit 33: Victorian Park Cable Cars - Waiting Room, Klussman Plaque, 1961-65.

Wilbur Smith Associates et al. *Muni E-Line Extension Feasibility Study Final Report, December 2004*. Prepared for the Presidio Trust, National Park Service, and MUNI, 2004.

Works Progress Administration. Project Files, Project No. 65-3-2014, 1935-38. WPA Microfilm Roll No. B-447.

Works Progress Administration, Division of Investigation. Case No. 7-CA-756 (Investigation of lease of Aquatic Park Casino to Leo and Kenneth Gordon), 14 November 1939. Records in National Archive, Record Group 69, Box 902, California, File 651, 109, Aquatic Park, San Francisco.



# APPENDICES

- Appendix A:** Treatment Workshop, Aquatic Park Cultural Landscape Report, April 25, 2007
- Appendix B:** Summary Statement of Significance and List of Contributing Resources, Aquatic Park, San Francisco Maritime National Historical Park
- Appendix C:** Skateboard Deterrents
- Appendix D:** Edge Treatments for Paving and Landscape Areas
- Appendix E:** Landscape Layout Plan, L1.0 (January 3, 2008)
- Appendix F:** Selected Aquatic Park Drawings on file, National Park Service, Pacific West Region





# Appendix A

## **Cultural Landscape Report, Aquatic Park San Francisco Maritime National Historical Park**

**Treatment Workshop  
25 April 2007  
Partnership Room, Building E**

### **Workshop Participants**

#### **SAFR**

Lisbet Bailey  
Stephen Canright  
Lynn Cullivan  
Marc Hayman  
Steve Hyman  
Robbyn Jackson  
Rob Kier  
Jack Lee  
Ted Miles  
Shelley Niedernhofer  
Stephen Rodgers

#### **PWR Oakland**

Denise Bradley  
John Hammond  
Kimball Koch

#### **PWR Seattle**

Cathy Gilbert

### **Purpose of the Workshop**

The purpose of this one-day workshop with park staff and the CLR project team was to:

- 1) Brief the park on the status of the project
- 2) Discuss some of the findings especially related to the evaluation of cultural landscape resources at Aquatic Park, and
- 3) Identify management and maintenance issues that need to be addressed in the treatment section of the report

### **Project Scope**

The purpose of the Cultural Landscape Report for Aquatic Park (CLR) is to document, evaluate, and recommend treatments for the cultural landscape resources at the park. The project began in February 2007. The need for the report is specified in the PMIS statement as a critical need for management and maintenance of the historic designed landscape within the National Historic Landmark. The CLR consolidates information from several other research and baseline documents, especially the park Cultural Landscape Inventory (CLI), 2004, and two baseline historical research studies: one by Delgado (1981), and one by Toogood (1980). The evaluation of landscape characteristics and features used in the CLR is largely excerpted from the CLI which also provided information about the significance of the designed landscape in the context of the existing NHL nomination. The focus of the CLR for Aquatic Park is on treatment and

management of the landscape to assure preservation, rehabilitation, and in some cases, restoration of missing components to promote sustainable maintenance practices and long-term stewardship of the historic district.

## **Project Status**

The team has completed a *60% draft of the CLR Part 1* including the site history, existing conditions, a summary of the analysis and evaluation from the CLI. Based on historical development, significance, and existing conditions influencing park operations and management, the CLR also defined and documented five cultural landscape character areas which will provide a framework for management zoning and treatment (see below).

Part 2 of the CLR includes the *Treatment* section and will be developed based on park objectives and current management documents, preservation of contributing resources defining the historic designed landscape, and direction from park staff about operations, visitor use, and maintenance practices. Work on the treatment section will begin in May with a 75% draft of the entire document available to the park for a three-week review by the end of June.

## **Workshop Summary**

After an introduction by Acting Superintendent Shelley Niedernhofer, Denise Bradley (Project Lead) briefed park staff on some of the findings from the cultural landscape report, and provided an overview of the framework for treatment provided in existing park planning and management documents. The primary park document outlining treatment is the General Management Plan, (1997), which states that development in Aquatic Park “must be compatible with preservation and interpretation of cultural values.” “Preservation, adaptive use, and commemoration” are identified as appropriate treatments. Under this broad management framework, the CLR will provide more specific recommendations for resources within the National Historic Landmark (NHL).

In this workshop, the discussion of treatment was organized following the four cultural landscape character areas defined in the Aquatic Park CLR. These areas include: **the Core Area** (the designed historic landscape), **Van Ness Street** (including Pocket Park), the **Bocce Ball Court Area**, and **Victorian Park**. A summary of these discussions follows below.

## Direction and Framework for Treatment

Based on discussions during the workshop the following framework will apply to all recommendations developed in the CLR

1. All treatments will be consistent with the park GMP, integrating park management objectives and the preservation of significant resources.
2. The CLR team will work with park staff to assure that all treatments for the cultural landscape are integrated with management and maintenance objectives for maintaining the integrity of the historic district.
3. The CLR team will assure treatments proposed in the CLR are compatible and/or integrated with existing and proposed interpretive plans and use within the district.
4. The CLR team will assure maintenance issues and sustainability objectives are addressed in the proposed treatments for long-term preservation of cultural resources at the site.

In addition, the treatment section of the CLR will include the following:

- **Management Philosophy** clearly outlining the overall preservation treatment strategy for the historic district based on the park objectives, direction in the GMP, and the *Secretary of the Interior Standards*. **Preservation** is the primary treatment applied to the historic designed landscape, with **rehabilitation** a secondary treatment allowing compatible adaptive use of the grounds to accommodate visitor use, interpretive services, NPS maintenance, and administration. Finally, in some cases, **restoration** is a treatment that may be applied to reestablish non-extant historic features critical to interpretation of the historic district.
- **Treatment Recommendations** will be prepared as written guidelines for treatment of significant cultural landscape resources in the framework of the historic district, current NPS operations, and interpretive goals. This section will also include any photographs and drawings needed to illustrate the recommendations. These recommendations may be developed in two tiers: overall recommendations that apply to the entire district, and more specific guidelines that apply to each of the four character areas or cultural landscape management zones defined in the CLR.
- **Schematics**. If project funds for the CLR permit, the park requested the team develop schematic design concepts for the bocce ball area in relationship to the future E-line through this area. These schematics may take into account possible alternative locations for the bocce ball court or development of a gateway to the park designed in conjunction with a train stop. The development of these schematics will be determined after the overall recommendations for treatment are completed.



## Summary of Workshop Discussions

### Four Character Areas

As mentioned above, the workshop treatment discussions were organized by the four character areas or cultural landscape management zones developed in Part 1 of the CLR. These five areas are the **Core Area** (the designed historic landscape), **Van Ness Street** (including Pocket Park), the **Bocce Ball Court Area**, and **Victorian Park**.

For each of these areas, treatment discussions followed the following format:

- 1) A brief overview of historical development and key landscape resources
- 1) Treatment issues for each area discussed during the workshop
- 2) A preliminary direction for treatment

### CORE AREA

A large part of the discussion in the workshop focused on the Core Area. Comprising the significant historic designed landscape, the Core Area is generally defined by Beach Street on the south, Van Ness Street on the west, the shoreline around the cove on the north, and the boundary with Victorian Park on the east.

#### Overview of Development and Key Features

##### Landscape Design

- Site plan developed by John Punnett (civil engineer) establishing a framework for physical development including the designation of planting beds, use areas, and circulation patterns. This was the first portion of the park design to be developed.
- The design and structure of Municipal Pier was important in protecting the cove **and** establishing the curvilinear form that carried through to the design of the seawall, planting beds, and pedestrian walkways defining circulation throughout the park
- The plan focused on functionality and clarity in site forms to complement the architectural style of the primary buildings and enhance the relationship between the buildings and grounds associated with the park. Attributes of the Moderne style as expressed in the landscape included the use of horizontal orientation of the ground plain (engineered grading of terraces around the bathhouse), rounded edges and curvilinear forms in the lay-out of walkways and circulation patterns, and the location of planting areas near the intersection of walkways, creating transitions.
- Importance of WPA Project (park built in short period of 2-3 years resulted in coherence of materials and style)
- Additions after period of significance
  - Victorian Park
  - Bocce ball area

## Buildings

- Designed by William Mooser Jr. (assistance from Elmore Hutchinson/civil engineer and William Mooser Sr./architect)
- Streamline Moderne style
- Collaboration between Mooser and engineers on some of the small scale structures and features of site plan (i.e. walls)

## Plant Materials

- Location of planting beds were developed as part of the [Punnett] site plan for the park; this plan laid out the location retaining walls, circulation features, and the planting beds.
- Actual planting plan developed by the San Francisco Park Commission in 1937 but never implemented. The plan consisted of curving beds with masses of plants (several species) and trees along edges of beds (see photos).
- Based on our assessment of historical data, it appears that individual plant materials used in the park were not as critical as the character of plant massing and relationship between open and planted areas.
- It is unclear who made actual selection of plant materials used at the park. Based on historic photographs, some plantings at the park changed more than once during period of significance
- Using historic photographs and aerials, the following conclusions can be made about the character of the plantings in Aquatic Park during period of significance:
  - Open, simple, supported form of "hardscape" (buildings, pavement, and walls)
  - Shrubs used in masses, single species, low profile
  - Plants around base of buildings/structures in some instances
  - No large trees on the grounds during the period of significance (Aerials *do* suggest that trees with a relatively large growth habit may have been planted during or immediately after the period of significance.)

## Small-scale Features

Small-scale features present during the period of significance include:

- light posts
- basalt block curbing and concrete curbing
- Bufano sculpture located at base of west bleacher.

## Issues Identified During Workshop

- Protection of contributing landscape characteristics and features including hardscape such as circulation surfaces, walls, concrete features, and basalt block structures. Address use of asphalt throughout the site. Asphalt is a non-compatible material and in several places, is in poor condition or impairs the condition of the historic walkway.
- Work with maintenance staff to make recommendations for restoration of planted areas focusing on the following:

- Defining the extent and form of historic planting beds throughout the core area
- Develop list of appropriate materials that address historic character, maintenance issues, and sustainability.
- Restore non-extant planting beds on Beach Street side of bathhouse
- Address ADA issues
  - Do grades of some of paths needs to be altered? Which ones?
  - Example of single bench at base of east bleachers as current solution of access issue. New east bleacher design may help with this.
- Bicycle use (conflict between bikes and pedestrians)
  - Commuters use park at thoroughfare, going very fast, use Van Ness (pick up speed coming down McDowell), speed on path that connects Van Ness and Beach (north side of bocce courts). Possibility redirecting bike traffic to North Point (part of city designated bike route system) might help reduce conflicts with commuter bikers
  - Tourists typically on Beach Promenade, riding slowly, not always skilled riders
- Need to maintain emergency/fire access. Wear on circulation features (also load issues).
- Need to repair basalt block. Curbing (vicinity sea scout bldg., south side of west convenience station). Also some missing blocks in sea wall (and other basalt walls?)
- Extent of asphalt (example: east bleachers)
- Potential to use hedges around new skylights
- Bare area around bus stop (on Beach). Irrigation not working there.
- Damage to sidewalk/curb on Beach Street. Due to not enough space for buses to get into stop. Solution of removing a couple of parking meters to give more room?
- Homeless population. Issues of safety and hygiene. Need to be aware of how plant materials can increase problem.
- "Planting creep" from Victorian Park into Core area. Intersection of Core with Victorian Park. Also need to more clearly delineate end of core area/beginning of Victorian Park.
- Small scale features
  - Issue of potential repair of light fixtures (wiring) along Beach Promenade.
  - Condition of benches and variety of types of benches. Park going to repair this summer/will use wood style throughout core.
  - Barbary Trail plaques in pavement. (seemed to be consensus these not problem.)
  - Another place to move "First Ship into San Francisco Bay" commemorative marker. Confusion it causes over importance of Aquatic Park.
- Need for better visual clues that are within a NHL and National Park
  - How do you know you are in a National Park?
  - Ways to differentiate from surrounding areas.
  - Work with park staff to identify appropriate places within the historic designed landscape for placing various types of signs including directional signs, wayside, and interpretive signs.
- Use of Sea Scout Bldg. for education.

Need for accessibility.

Area between sea scout and Van Ness to accommodate ramp.

How might this use of Sea Scout alter use of "pocket park" area on west side of Van Ness?

Concrete between seawall and Van Ness in the area north of the Sea Scout.

### **Focus for recommendations/treatments**

- Preservation of contributing resources and in some cases, restoration of non-extant features (planting beds)
- Prepare a comprehensive planting plan for the core area that incorporates the significant characteristics of the landscape during period of significance, and also addresses maintenance needs for safety, security, and sustainability.
- Develop design vocabulary for small-scale features (signs, garbage cans, benches, etc) within the Core Area

### **VAN NESS STREET**

The Van Ness Street area in the CLR is defined on the west by the boundary line for Fort Mason in GGNRA, on the north by Municipal Pier, and on the east by the Core Area as defined above.

### **Overview of Development and Key Features**

- 1910: wall on west side of Van Ness
- 1913: seawall and fill on west side of cove
- 1914: tunnel and fill
- 1931: seawall part of Municipal Pier project
- 1937: Van Ness extended after WPA seawall built
- By 1943: garage in area west of Van Ness; fenced in and part of Fort Mason
- 1975: Pocket park: berms, plantings, brick area with benches, brick paths, bed at pump house

### **Key Features**

Concrete road

Concrete sidewalks

Cast concrete lamp posts (ones that remain have been retrofitted with cobra lights)

### **Issues Identified During Workshop**

- Pocket park is non-contributing feature. CLR should help determine the use and character of this area based on historical data. Bricks are slippery (wet/moss). Park plans to remove brick paving and benches by this summer.
- Opportunity to use pocket park area for other uses? i.e. Place to move bocce courts? Other? Restrictions?



- Street trees. Condition of sidewalk due to trees. Check aerial photos again on presence of trees or planting wells for trees in the sidewalks (in 1948 aerial). Double check to clarify if street trees were planted within the period of significance. Should they be replaced when fail or hazard? If so, how should this be done –i.e. all at once, or not at all?
- Roadbed is poured concrete. Contributing feature needs repair?
- Loss of historic light fixtures (were similar to ones along Beach Promenade). Poles missing. Remaining ones been retrofitted with cobra lights.
- GMP update should address Van Ness as an entry to the park. Important for CLR to describe what is important to retain.
- Parking may be a GMP issue (public parking, park visitor parking, maintenance and park staff parking, use for large public events).
- Condition of seating/overlook above bocce ball area. Asphalt paving. Trees scheduled to be removed (arborists report). Potential for this area for park sign and/or interpretive sign.
- Views of core as enter from Van Ness. Trees blocking view at northwest corner of bocce area on Van Ness. Trees scheduled to be removed. Seating area could be removed (non-contributing). Opportunity for signage?
- Adjacent hillside (Fort Mason). Highly recommend park work with GGNRA to remove overgrown vegetation on this slope to restore important views, the historic character and reduce health and safety problems

### **Proposed Treatment**

- Preservation/restoration of historic features (road, sidewalk, light fixtures)
- Maintain current character as a transition between designed landscape (NHL) and Fort Mason

## **VICTORIAN PARK**

Victorian Park is a distinct park unit located east of the Core Area. Built in 1962 by the California Department of Beaches and Parks, it comprises approximately one block and is the location for the cable car turnaround. It is defined on the west side by the pedestrian walkway at the east edge of the bleachers, on the north by Jefferson Street, on the east by Hyde Street, and on the south by Beach Street.

### **Overview of Development and Key Features**

- WPA project: This block of land was not developed during the period of significance but was labeled as "Property to be reserved for future Parks & Development" on the ca. 1936-37 Plot Plan for Aquatic Park
- 1956: Cable car turnaround for the Powell-Hyde Line built in the southeast corner of the site
- 1962: Victorian Park (landscape architect Thomas Church provided input that was incorporated into the final plan that was prepared in 1961)
- Ca. 1982: Cable car turnaround relocated. Resulted in significant alterations to the 1961 park design

## Key Features from 1961 design

- East-West axis and North-South axis from cable car turnaround
- Plaza and paths
- Use of plants:
  - Single species in large mass on ground plane
  - Trees planted in rows to emphasize edge (Beach Street) or axis (in plaza).

Victorian-style site furnishings

Hardscape materials (concrete, decomposed granite, basalt block edging)

Develop recommendations to enhance compatibility with Aquatic Park

Views into cove and Aquatic Park

## Issues Identified During Workshop

- Problems as a result of ca. 1982 redesign of cable car area and subsequent addition of hedge and perennial plants
  - Plant materials block views of Aquatic Park and within/into Victorian Park
  - Plant materials not compatible with Aquatic Park
  - Interlocking pavers around cable car turnaround (condition/safety, non-compatible material)
  - Asphalt paving (non-compatible material, condition of material, visual impact)
  - Visual clutter within cable car area
- Need for Victorian Park to be evaluated for potential significance on its own merit (possible areas of significance: association with Karl Kortum, development of maritime history park, design influence of Thomas Church). Discussed with Robbyn after meeting; **this would be done separately and not part of this CLR.**
- Removing agapanthus along Beach Street. Existing problems: poor condition of plants, contributes to safety issues, blocks views, social paths. In addition, until a DOE is completed, removal of agapanthus plants may be considered as potential effect because there were planted as part of the 1961 design.
- Removal of hedge may increase foot traffic down hill.
- Issues related to replacing perennial plants in large beds that border north side of plaza/cable car area: establishment of plants, people walking thru areas, weeding, mulch, blowing.
- CLR can help frame parameters for general treatment that address a number of current use issues.
- While the CLR can address treatment that enhances connection to Aquatic Park, overall proposals for use and treatment issues for Victorian Park are best addressed in a GMP update.
- Maintenance of plantings at Victorian Park require a disproportionate amount of labor for a non-contributing feature of the NHL district
- Condition of Victorian-style site furnishings.
- Safety, hygiene, transient population issues.
- Boundary between Aquatic Park and Victorian Park. Differentiate plantings, site furnishings. Amount of asphalt here.

- Location of commemorative elements. Conflict with location of Barbary Trail feature and steps into park (from Beach Street)

### **Proposed Treatment**

Treat as separate area from core and use 1961 design to guide decisions (materials, plant character, views) in Victorian Park

- Enhance visual connection and compatibility with Aquatic Park
- Maintain Victorian-style site furnishings and features that are identified with the 1961 design. (This is the date of the “as-built” design. Maintaining this landscape would preserve the remaining features from that period, until the park can determine if the 1961 design has historical significance )

### **BOCCE BALL COURT AREA**

Located in the southwest portion of Aquatic Park, this triangular-shaped area is defined on the north by the Aquatic Park pedestrian circulation path and basalt block retaining wall (with stone acorns), on the south by Beach Street and a wall of the building located at 3250 Van Ness Avenue, and on the west side by a concrete retaining wall (along the east side of Van Ness Avenue).

### **Overview of Development and Key Features**

- WPA project: This area was not developed but was labeled as “Future Park Development” on the ca. 1936-37 Plot Plan for Aquatic Park
- By 1948: Bocce ball play (informally used for this recreational activity soon after city water pumping station torn down) Still need date.
- 1960-61: Bocce ball overhead structures, two courts, raised planting bed on north side, wood retaining wall, overlook area at Van Ness, clubhouse (not clear on date this added to site)
- 1967: Commemorative fountain

### **Key Features**

Level grade throughout area

Concrete retaining wall on west side

Basalt block retaining wall (with stone acorns) on north side

Bocce court complex

Lawn

Fountain

Lombardy Poplars

### **Issues Identified During Workshop**

- Compatibility of the design of this non-contributing area in relation to the historic designed landscape of Aquatic Park NHL district.
- Safety issues with wood retaining wall
- Safety and condition of trees on west side

- Asphalt path (non-compatible material, condition of material, visual impact)
- Overgrown plants in beds (block views, safety issue, plant materials not compatible with Aquatic Park)
- Plantings require disproportionate amount of labor for a non-contributing feature within the NHL district
- Non-functioning commemorative fountain.
  - Water line not functioning?
  - Does not meet current health standards (water pools in bottom of fountain).
  - Problem of fountain heads being removed/vandalized.
  - Missing commemorative plate.
- Need to relocate fountain? Way to make it feel more a part of bocce ball area?
- Possible general location for a park maintenance facility for waste management (transfer and recycle). Can this be integrated in compatible manner, or is this a larger GMP issues regarding overall maintenance facilities?
- Bocce ball players like this area because out of wind. Current concrete courts are wrong dimensions for international rules but are able to delineate courts to correct dimensions in dirt area.
- Lombardy poplars along Beach Street.
  - CLR should recommend treatment of these trees (and all non-contributing vegetation). Trees may have other values (shade, screening, microclimate control, etc.) that need to balance maintenance concerns and public values. What are maintenance/views issues with Lombardy poplars?
  - If trees removed, what (if anything) might replace them?
- Create guidance for overall tree management (**park-wide** concern). Reference arborists report (appendix in CLR?)
- E-Line Issues
  - Where is stop going to be located?
  - Preservation of historic features: topographic features (level area of, walls, grading); circulation
  - Visual intrusion of wires and possible stop from core of park
  - Auditory intrusions into core
  - Need to move bocce courts. Suitability of Victorian Park or Pocket park (west of Van Ness)? Bocce ball players want an indoor facility for tournaments.
  - CLR to present conceptual drawings that accommodate E-Line
  - Get updated E-line plans from Robbyn

## Proposed Treatment

- Preserve and protect contributing features
  - Level area (contributing topographic characteristic)
  - Concrete retaining wall on west side (contributing feature)
  - Rubble retaining wall (with stone acorns) on north side (contributing feature)
- Enhance compatibility (design and materials) with Aquatic Park
- Bocce ball is considered a compatible use (recreation)
- Address treatment in relationship to E-Line and park entrance feature possibly using schematics



## Appendix B

### Summary Significance <sup>1</sup>

The historic designed landscape comprising the Aquatic Park National Historic Landmark District is significant under National Register Criteria A and C. The period of significance is between 1920, when the initial construction of the park began by the city, and 1945 representing the end of the military use of the park during World War II. Aquatic Park is significant in the area of community planning and the history of the Works Progress Administration (WPA) and the Federal Arts Project in San Francisco during the 1930s. Additionally, Aquatic Park is an outstanding example of the Streamlined Moderne style applied to the design of both the buildings and designed landscape.

### Summary Physical Integrity

The historic designed landscape of Aquatic Park retains all seven aspects of integrity:

- *Location.* The location of Aquatic Park along a narrow crescent of land that wraps around the Aquatic Park cove and the proximity of the park to the bay remains from the period of significance and retains integrity of location.
- *Design.* The building and structures in Aquatic Park were collectively designed in the Streamlined Moderne style. In addition, many of the landscape components designed and implemented in Aquatic Park echoed characteristics of this style including the curvilinear design of the seawall and Beach Promenade and the highly engineered terraces that provide the setting and context for the buildings. At Aquatic Park, a formality of design and the relationship between the buildings and the grounds enforce this design aesthetic. The choice of a light-colored concrete as the surface material for the pier, promenades, and retaining walls worked to unify the design, linking the landscape structures with the prominent buildings throughout the park. Although the planting plan developed from incremental efforts rather than adherence to one particular plan, the simple plant palette of large open lawns, masses of low shrubs, and foundations plantings was highly compatible with the aesthetic of the Streamlined Moderne style.

The key characteristics and features comprising the designed landscape of Aquatic Park include the manipulated grade and topography, the historic spatial organization, historic structures and buildings, the design of circulation features, and the patterns and character of historic vegetation.

Most of these key features remain today. The absence of some vegetation such as the hedges is one of the few exceptions. Additionally, the poor physical condition of the

---

<sup>1</sup> Portions of this summary are excerpted from the existing nomination and from the Statement of Significance in the Cultural Landscape Inventory, Aquatic Park, 2004.

Municipal Pier threatens the structural integrity to the degree the treatment of the structure is being addressed a separate project.

Physical changes have occurred to the grounds around Aquatic Park since the period of significance. Clearly, the most dramatic changes occurred after the mid-1940s in areas adjacent to the original historic designed landscape including the addition of facilities for the bocce ball courts in the southwest corner of the park, the construction of Victorian Park, and to a lesser extent, the redesign of the area west of Van Ness Avenue in the 1970s. Although all of these developments have some association to Aquatic Park in terms of proximity, materials, and visual impacts, all are considered visually and/or functionally compatible to the historic design as implemented by the Works Progress Administration (WPA).

- *Setting.* During the period of significance, the immediate setting north of the park was the bay; to the east were low commercial buildings and wharves related to maritime commerce; to the west was the steep hillside of Black Point; and to the south was the urban development of the city. Today, this setting remains in place, and Aquatic Park retains its integrity of setting. However, the uses of the buildings in the areas east and south of the park have changed. Today, land uses are predominantly related to tourism rather than to maritime commerce. The addition of a 16-story apartment building on the south side of the park has resulted in an alteration of the setting on the south side of the park.
- *Materials/Workmanship.* Concrete is a characteristic material of the Streamlined Moderne style and was the predominant material used for the buildings and structures in Aquatic Park. The curved concrete planes of the exterior of the buildings and structures (deck and parapet of the Municipal Pier, Bathhouse, bleachers, three convenience stations, and two speaker towers) and retaining wall on the south side of the Beach Promenade are examples of the characteristic workmanship associated with the concrete at Aquatic Park. Concrete on the buildings was painted white adding to the visibility of the buildings and structures and enhancing curved forms on the exteriors. Concrete was also used as the predominant paving material for primary walkways and circulation features (Beach Promenade, paving on the north side of the Bathhouse, ramps around either end of the Bathhouse, steps, and sidewalks on Van Ness Avenue, and Beach, Jefferson, and Hyde streets). Additionally, it was used in curbing (on the Municipal Pier, to form the edges of sidewalks, and to form planting beds) and for the benches at the Municipal Pier.

Cast concrete was used for the bases of light fixtures along the Beach Promenade, Van Ness Avenue, the Municipal Pier, and Beach Street. These light fixtures appear to be one of the standard types of light fixture that were used in the city during this period (and can still be seen throughout the city; although generally retrofitted with cobra light fixtures).

Salvaged materials such as basalt blocks and granite headstones (from city cemeteries) also used in construction of the park, also remain evident today. Basalt blocks were used for the stepped seawall, the retaining wall in the upper terrace, and for the edging or curbing around planting beds. Granite headstones and other stone materials were used to construct the seawall and the retaining wall located along the south side of the promenade. The granite acorns located on the top row of this wall are also an example of salvaged material.

Round metal railings are a characteristic feature of the Streamlined Moderne style and were used along the edges of the decks at the Bathhouse, the convenience stations, and the bleachers; as grills in the speaker towers; and as hand railings in the bleachers.

Characteristic plant materials included extensive lawns, hedges or rows of plants (at the base of the speaker towers, around the skylights, and around the foundations of some of the buildings); mass plantings of a single low-growing species in the planting beds on the west side of the Bathhouse, where the slope of the beds may have made establishment of lawns difficult.

With the exception of the loss of the Bufano sculpture(s) and the use of the hedges around the foundations of buildings, these materials and the associated workmanship remain in place. Changes to materials and workmanship since the end of the period of significance are reflected in the addition of new materials. The greatest concentration of these changes is in areas adjacent to the designed landscape of Aquatic Park (such as the bocce ball area, Victorian Park, and to a lesser extent, the open area on the west side of Van Ness Avenue). Within the core area of the park the use of non-historic materials are reflected in the expanded use of asphalt as a paving material for sidewalks and curbing and additions of contemporary small-scale features such as trash receptacles, bike racks, signs, etc.

- *Feeling.* During the period of significance Aquatic Park was a green space surrounded by and contrasted with commercial and industrial areas. Primary use of the park by the public was for recreation and the design of the landscape accommodated a variety of user groups. Today, commercial businesses remain adjacent to the park focusing on tourism and Aquatic Park continues to provide a variety of recreational opportunities to the public as it has of over 100 years.
- *Association.* The historic designed landscape of Aquatic Park retains integrity of association as a park focused on aquatic recreation in San Francisco; as a significant park built by the WPA; and as an outstanding example of the Streamlined Moderne style applied to the design of both the buildings and designed landscape.



## List of Contributing and Non-Contributing Features

This list is excerpted from the Aquatic Park Cultural Landscapes Inventory, 2004, and the List of Classified Structures for San Francisco Maritime National Historical Park, and Golden Gate National Recreation Area. Structure numbers are from maintenance files in both park units.

Feature	Status	LCS ID	Structure No.
<b>Buildings and Structures</b>			
San Francisco Municipal Pier	Contributing	010182	FMO-0400
Bathhouse	Contributing	010180	AP-0001
West Convenience Station	Contributing	010181	AP-0002
East Convenience Station	Contributing	010186	AP-0011
Bleachers (East)	Contributing	010187	AP-0016A
Seawall	Contributing	010189	AP-0018
Speaker Tower (West)	Contributing	010190	AP-0019
Speaker Tower (East)	Contributing	010191	AP-0020
Bleachers (West)	Contributing	058261	AP-0016B
Southwest corner Retaining walls	Contributing	220319	AP-0029
Sea Scout Building and dock	Contributing	330107	
<b>Circulation and other Structures</b>			
Beltline Railroad Tracks	Contributing	092665	AP-0023
Walkway System	Contributing	220312	AP-0023
Beach Promenade	Contributing	220313	AP-0024
Bathhouse Ramps	Contributing	220314	AP-0025
Beach Street sidewalk	Contributing	220315	AP-0026
Van Ness Avenue Sidewalks	Contributing	332653	AP-0031
Basalt Block curbing	Contributing	220316	AP-0027
Aquatic Park Light Fixtures (precast concrete posts with glass globes)	Contributing	332655	



**Vegetation \*\* \*\*** The Cultural Landscape Inventory (CLI) indicates vegetation *is not* a contributing characteristic of the designed landscape. However, the CLI does identify plant materials that date to the period of significance. These materials are documented below.

6 junipers in the small foundation planting beds on the north side of the Bathhouse	Contributing (to the historic character)	N/A
Grecian Laurels around the east and west speaker towers	Contributing (to the historic character)	N/A
Lawn areas throughout	Contributing (to the historic character)	N/A

### NON-CONTRIBUTING - Small-scale features

Benches	Non- Contributing	N/A
Trash Cans	Non- Contributing	N/A
Bollards or Posts	Non-Contributing	N/A
Water Fountains	Non-Contributing	N/A
Fencing	Non-Contributing	N/A
Asphalt curbing	Non-Contributing	N/A
Signs	Non-Contributing	N/A
Metal plaque commemorating "First Ship into San Francisco Bay" mounted in uncut stone boulder	Non-Contributing	N/A
Barbary Coast Trail markers: located in pavement on promenade and sidewalks on west side of Victorian Park	Non-Contributing	N/A
Buoys/markers in cove	Non-Contributing	N/A
Anchor in planting bed between the Beach Promenade and the north side of Bathhouse	Non-Contributing	N/A
Propellers in planting bed on west side of East Convenience Station	Non-Contributing	N/A
Metal tube bike rack (west end of Beach Street side of Bathhouse)	Non-Contributing	N/A

# SKATE STOPPERS

Appendix C

## Skate Deterrents

### Architectural Series

Custom or stock cast aluminum and bronze in a variety of motifs and profiles.

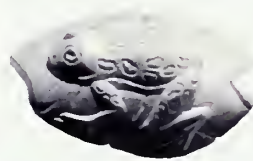

### Handrail Series

Stock parts fit most standard handrails.



### Integrated Series

This patent pending line integrates the skate deterrent into your hardscape during construction.



### Fixed Angle/ Fixed Radius Series

Demanding applications require rugged parts. Parts in this line are extruded from aircraft grade aluminum.

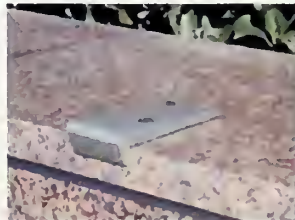

Now that you have spent hundreds of thousands of dollars on hardscape, it's time to protect your investment from skaters and BMX cyclists. Whether you need a simple product from our "workhorse" line or an elegant deterrent to match an existing architectural theme, Skatestoppers is your choice for value, quality, and durability. Ask us how our patented pinning solution provides extraordinary strength without inducing stress on the mounting surface.

For more information, visit us at [www.skatestoppers.com](http://www.skatestoppers.com) or call 619-447-6374.



SkateStoppers is a trademark of Intelliccept

# ECO-FRIENDLY LASER Series

The new LASER Series combines the sleek lines of our popular INSERT Series with the ease of a surface mount part. These parts are cast from either of two recycled, **environmentally friendly** alloys:

- White Tombasil
- Silicon bronze



"Childress"  
for 1/8" radius  
(shown in White Tombasil)



"Morgan"  
for 1/2" radius  
(shown in White Tombasil)

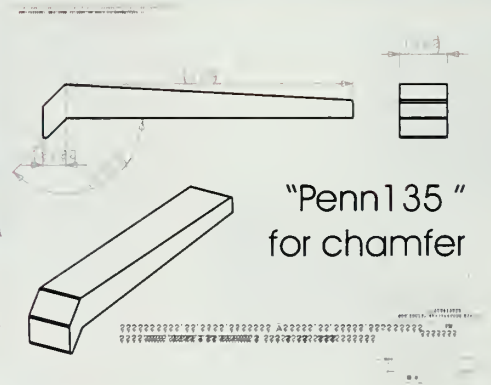

"Penn135"  
for chamfer

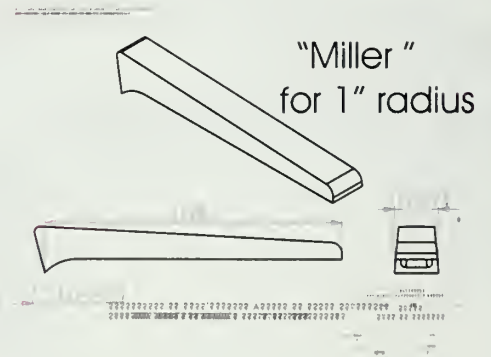

"Miller"  
for 1" radius

- Radius:** "Childress" for 1/8" Radius
- "Morgan" for 1/2" Radius
- "Miller" for 1" Radius
- "Penn135" for Chamfer

**Standard Width:** 1"

**Length:** Approx 6"

**Recycled Material:** White Tombasil or Silicon Bronze  
(ingot is made in USA and lots are certified for alloy content)

**Bronze Finish:** Brown Patina

**WhiteTombasil Finish:** Brush Finish with clear coat seal

**Anchoring:** 2 Blind SMART PINS PLUS anchor pins set with two part epoxy.

**Product Spacing:** 12"-18" from ends/corners and approximately 36" +/- 6". When working on precast blocks/capstone or stone, layout will be dictated by uniformity of spacing relative to grout lines. **DO NOT ATTACH AT GROUT LINES OR EXPANSION JOINTS.**





# FA-FR Series Products

Skatestoppers is a trademark of Intelliccept



FA 902.5

This patented part is designed for 90° edges with a 1/2" radius. Most commonly used on poured cement applications.

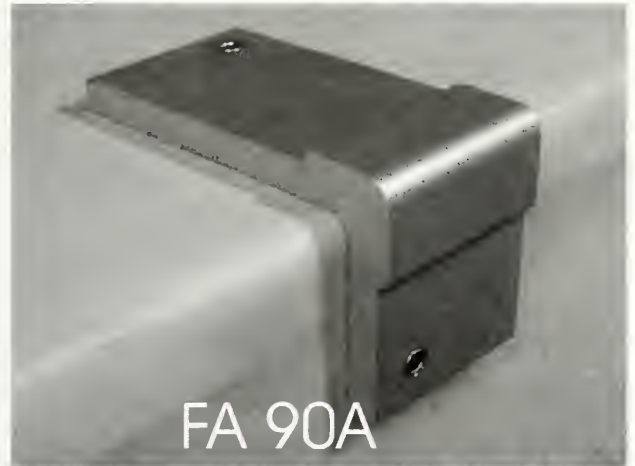

FA 90A

This patented part is designed for 90° edges with a 1/8" radius. Most commonly used on granite, marble, stone, block, or other surfaces with a hard corner.



FR0.12

This part is designed for edges that have a 1/8" radius (may be used in place of FA90). Most commonly used on granite, marble, stone, block, or other substrates with a hard corner. May also be used on wood or aluminum seating.



FA 13E

This patented part is designed for chamfered edges (edge is formed at a 45 degree angle). Most commonly used on poured concrete, but may be found in granite, limestone, and marble.



Skatestoppers is a trademark of Intellicept

## FA-FR Series Products cont'd



FR0.5

This part is designed for edges that do not form a 90° angle and that have a 1/2" radius (formerly FA901.5). May be substituted for FA902.5. Appropriate for most cement benches with 1/2" radius when specifying SMART PINS .



FR1.0

This part is extruded from 6061-T6 aluminum and is designed to fit 2" bullnose (1" radius). Also may be used on 1" radius troweled concrete.

## Bullnose Castings



- ASBullnose90
- ASBullnose0.5
- ASBullnose1.0
- ASBullnose1.25
- ASBullnose1.50
- ASBullnose2.00
- ASBullnose3.00

These parts are cast from aluminum or bronze and are designed to fit  
1/4" bullnose (.125" radius)  
1" bullnose (0.5" radius)  
2" bullnose (1" radius)  
2-1/2" bullnose (1.25" radius)  
3" bullnose (1.5" radius)  
4" bullnose (2.0" radius)  
6" bullnose (3.0" radius)  
Parts incorporates Intellicept's SMART PIN PLUS design.

ASBullnose 1.5 for 1.5" Radius Bullnose

ASBullnose 1.25 for 1.25" Radius Bullnose

FR1.0 for 1.0" Radius Bullnose

FR0.5 for .5" Radius Bullnose

FR0.12 for .125" Radius

FA90A - 90 degree bracket  
with .125" Radius

FA902.5 - 90 Degree Bracket  
with .5" radius

FA135 for Chamfer

FA90CC - .5" radius bracket (primarily for curbs)

FR0.25PC for  
Plastic Coated Benches  
or Fiberglass Benches

NOTE: This sheet was generated at full scale. Verify that fax transmission or reproduction did not change scale prior to use of this template set. Measure and verify that the noted 1" dimension of the FA135 above is 1". If the marked dimension is not 1", enlarge/reduce sheet accordingly.

INTELLICAPT, CA USA  
tel 619-447-6374

STANDARD PRODUCT PROFILES

Cut out shapes and check  
which shape fits best prior  
to ordering.

THE INFORMATION CONTAINED IN THIS DRAWING IS THE SOLE PROPERTY OF Intellecept. ANY REPRODUCTION IN PART OR WHOLE WITHOUT THE WRITTEN PERMISSION OF Intellecept IS PROHIBITED.

SMART PINS PLUS  
Tamper Resistant Set Screw  
(5/16-18 x 2") Hardened steel  
with zinc plate and JS500  
coating.

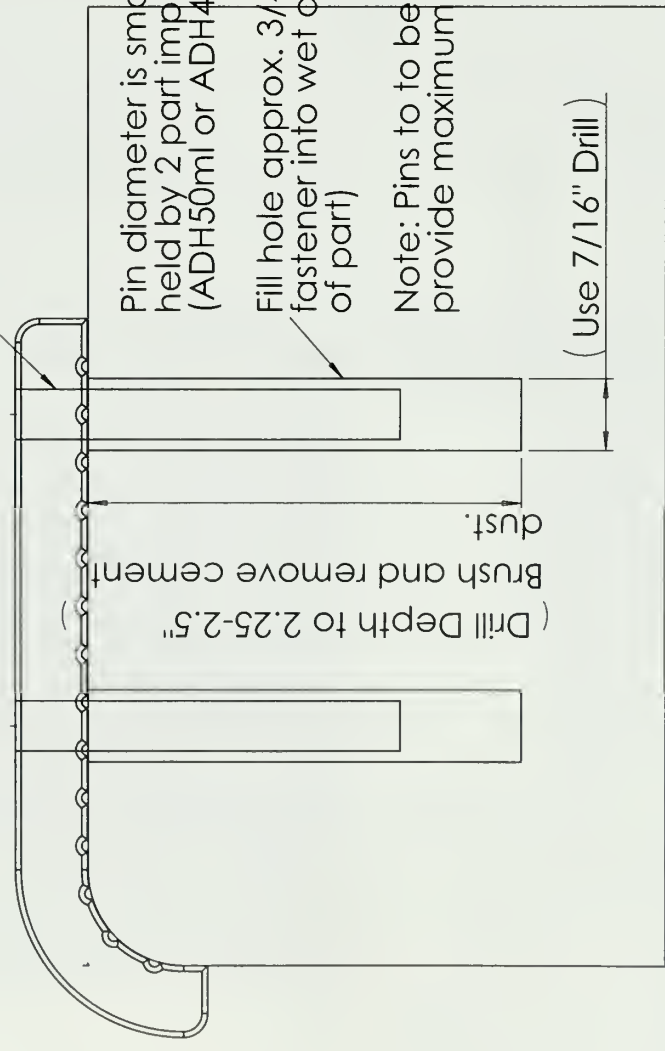

Pin diameter is smaller than drilled hole. Pin held by 2 part impact resistant adhesive (ADH50ml or ADH400ml)

Fill hole approx. 3/4 with adhesive. Screw fastener into wet adhesive (flush to surface of part)

Note: Pins to be screwed into adhesive to provide maximum bond strength.

( Use 7/16" Drill )

( Drill Depth to 2.25-2.5" Brush and remove cement dust. )

UNLESS OTHERWISE SPECIFIED  
DIMENSIONS ARE IN INCHES

INTELLECT, CA USA  
619-447-6374

Sample Installation  
SMART PINS PLUS  
anchoring system

MATERIAL

FINISH

Zinc Plated Steel  
Pin set in counterbore  
(pin set below surface)

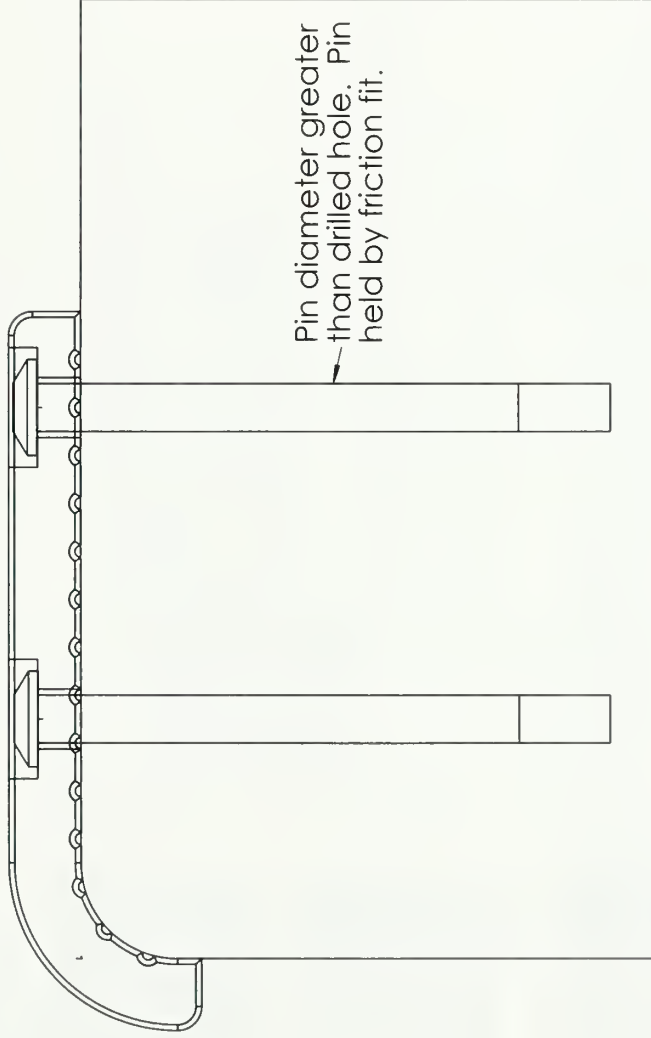

UNLESS OTHERWISE SPECIFIED  
DIMENSIONS ARE IN INCHES

MATERIAL

FINISH

INTELLICEPT, CA USA  
619-447-6374

FR0.5CB  
(Installation showing  
Spiral Drive)

SCALE

CAD FILE

SHEET



THE INFORMATION CONTAINED IN THIS DRAWING IS THE SOLE PROPERTY OF INTELLICEPT. ANY REPRODUCTION IN PART OR WHOLE WITHOUT THE WRITTEN PERMISSION OF INTELLICEPT IS PROHIBITED.

Product to be spaced on 30-36" centers and approximately 12-18" from the end points. Be sure that product is spaced evenly from end points.

Step One:

Drill  $\phi$  5/16" thru holes for bolts.

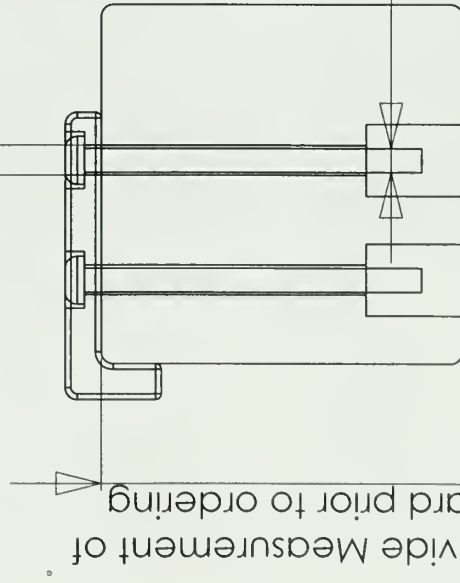

Step Two: Counterbore

Use wood auger/spade bit to counterbore hole so nut and washer set beneath surface.

Step Three:

Apply Loctite #262 Threadlocker to bolt (at the point where nut engages). Drop bolts thru. Secure with washer and nut.

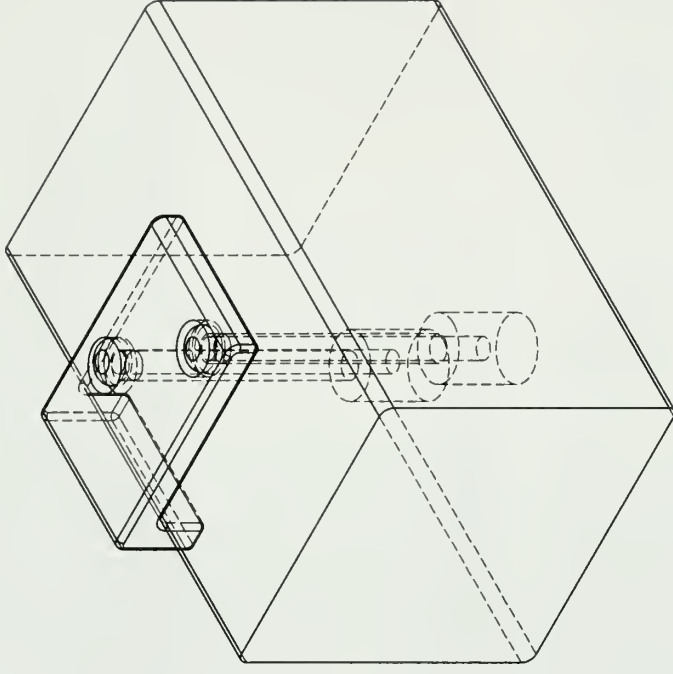

INTELLICEPT  
SAN DIEGO, CALIFORNIA, U.S.A.

Sample Carriage  
Assembly

SIZE DWG. NO.

A

F

**Permaloc Products**

HOME PAGE

ABOUT PERMALOC

FAQ

DESIGN TRENDS

INTERNATIONAL

MARQUEE PROJECTS

DISTRIBUTORS

CONTACT

LINE MAP



**LIVE HELP CHAT:**  
Product specialists are available to you



**PERMALOC WORLDWIDE:**  
Permaloc's products can be found globally.



**Landscape Edgings**

Permaloc offers a wide variety of landscape edgings for every application, whether residential or commercial. Common applications for landscape edgings are landscape beds, maintenance beds, tree rings, flower beds, and crushed stone pathways.

Products Include: CleanLine, CleanLine XL, ProLine, YardEdge, Onyx, PermaStrip, and DesignEdge.

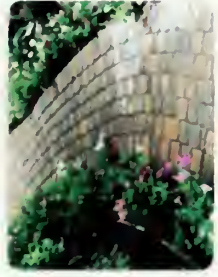

**Landscape Restraints**

Permaloc has the most complete line of landscape restraints in the industry, offering a range of products for residential and commercial applications. Common applications for landscape restraints are brick patios and walkways, asphalt surfaces, athletic surfaces, and cart paths.

Products Include: StructureEdge, BrickBlock, AsphaltEdge, AthletiEdge.



**Green Build Products**

Permaloc manufactures the most versatile, complete line of green roof edgings and restraints in the industry. Our unique products are ideal for all types of greenroof systems. From traditional systems to modular systems, we have a green roof edge to meet the needs of any rooftop garden, whether intensive or extensive.

Products Include: GeoEdge.

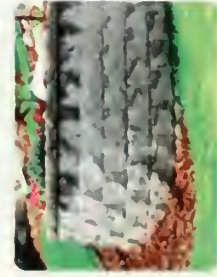

**Accessories**

Permaloc is dedicated to manufacturing quality accessories that allow for quick and easy installation of our products. Whatever your application we are dedicated to providing you the accessories needed to save time and effort.

Products Include: Grade Change Connector, End Stake Adaptor, Connectors, Aluminum Stakes, Steel Stakes, and Steel Spikes.



**STUDENTS:**  
Information for landscape  
architecture students

## Landscape Edgings



### **CleanLine™ Aluminum Landscape Edging**

Permaloc CleanLine is a complete series of commercial grade aluminum landscape edgings designed to function in professional landscapes.



### **CleanLine XL™ Aluminum Landscape Edging**

Permaloc CleanLine XL is a complete series of commercial grade aluminum landscape edgings designed for applications requiring extra durability and depth.



### **ProLine™ Aluminum Landscape Edging**

Permaloc ProLine professional quality aluminum landscape edging designed for use in residential and light commercial landscapes.



### **YardEdge™ Aluminum Landscape Edging**

Permaloc YardEdge professional quality aluminum landscape edging designed for use in residential landscapes.



### **Onyx™ Plastic Landscape Edging**

Permaloc Onyx professional quality plastic landscape edging designed for use in residential and light commercial landscapes.



### **PermaStrip™ Aluminum Maintenance Strip**

Permaloc PermaStrip is a rigid, L-shaped aluminum maintenance strip specifically designed to make straight runs bordering buildings, fences and other maintenance problem areas.

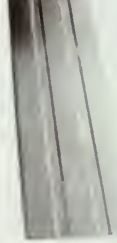

### **DesignEdge™ Aluminum Freeform Edging**

Permaloc DesignEdge is a quality aluminum edging designed to be formed freely to create garden art and planting areas of any shape.

or, pavers, walkways, entryways, curbs, ramps, and other paver installations.

### BrickBlock™ Aluminum Paving Restraint

Permaloc BrickBlock is a flexible L-shaped aluminum paving restraint designed as an edge restraint for patios, walkways, entryways, and other paver installations.

### AsphaltEdge™ Aluminum Paving Restraint

Permaloc AsphaltEdge is the only product available which is specifically designed to perform as an integral edge restraint system for asphalt.

### AthletEdge™ Aluminum Sports Surface Restraint

The Permaloc AthletEdge family of products is the first restraint system in the world to be designed to perform integrally with asphalt and sport surfacing.

### GeoEdge™ Aluminum Green Build Restraint

Permaloc GeoEdge is a flexible, multi-height, durable aluminum edge restraint and component system specifically designed for use in a green build environment.

### Accessories

Permaloc offers a wide array of accessories to be used in connection with our products or as stand-alone products in the landscape.



### Green Build Products

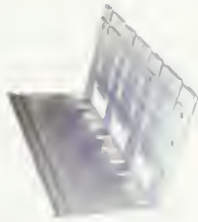

### Accessories





HOME PAGE

ABOUT PERMALOC

FAQ'S

DESIGN TOOLS

INTERNATIONAL

MARQUEE PROJECTS

DEALER LOCATOR

CONTACT US

SITE MAP



**LIVE HELP CHAT:**  
Product specialists are available to you



**AsphaltEdge**  
Aluminum Asphalt Restraint



AsphaltEdge™ is a line of flexible, L-shaped aluminum asphalt restraints. One of the biggest drawbacks of asphalt compared to concrete and brick is an inconsistent edge. With Permaloc AsphaltEdge, you get a strong, uniform 90-degree edge. It installs quickly and easily, making your work stand out and providing a "finished look" - an excellent complement to any asphalt installation.

- Engineered to extend the life of asphalt pavement by helping to prevent broken edges, providing uniform thickness throughout the pavement surface, and providing a finished, maintainable look along the asphalt border.
- Permaloc's patented AsphaltEdge is the only product specifically designed to be installed and perform as an integral restraint system for asphalt.
- AsphaltEdge is designed for asphalt over aggregate, asphalt overlay, and asphalt over concrete, including residential, commercial and industrial applications.

**Sizes & Finishes (wall x base)**

- 1" x 2-1/4" (25.4mm x 57.15mm) For asphalt applications
- 1-1/2" x 2-1/4" (38.1mm x 57.15mm) For asphalt applications
- 2" x 2-1/4" (50.8mm x 57.15mm) For asphalt applications
- 2-1/2" x (63.5mm x 57.15mm) For asphalt applications

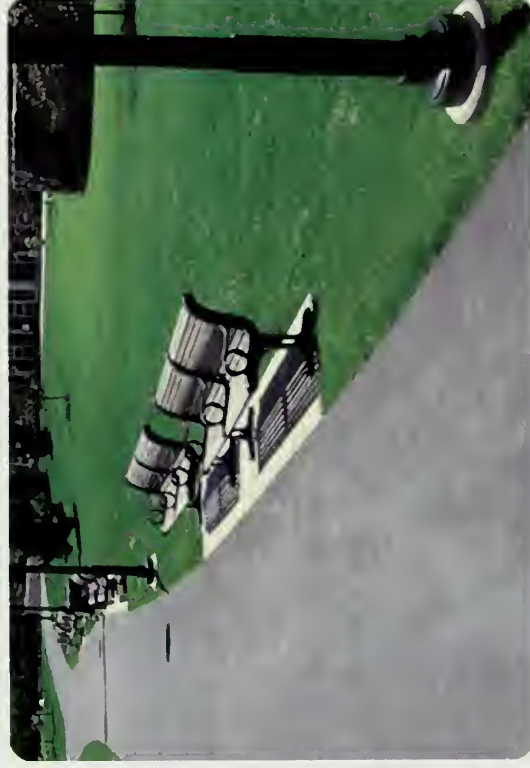

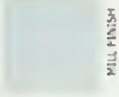

MILL FINISH



BLACK DOUBLE

### Application Detail Downloads

Asphalt Restraining Single Course of Asphalt over Compact Gravel Base Asphalt Running Track  
 Restraining Single Course of Asphalt over Compact Gravel Base  
 CAD Files AE-1

PDF

DWG

Asphalt Restraining Double Course of Asphalt over Compact Gravel Base Asphalt Running Track  
 Restraining Double Course of Asphalt over Compact Gravel Base  
 CAD Files AE-2

PDF

DWG

Asphalt - Restraining Finish Course of Asphalt over Asphalt Base (Binder) Course  
 CAD Files AE-3

PDF

DWG

Asphalt - Restraining Finish Course of Asphalt over Concrete Base  
 CAD Files AE-4

PDF

DWG

Asphalt - Restraining Double Course of Asphalt over Concrete Base  
 CAD Files AE-5

PDF

DWG

DG/Aggregate - Restraining Decomposed Granite or Aggregate over Compact Base Driveway/  
 Walkway/Running Track  
 CAD Files AE-6

PDF

DWG

Paver - Restraining Paver and Setting Course over Asphalt Base  
 CAD Files AE-7

PDF

DWG



# PERMALOC ASPHALTEdge

ALUMINUM ASPHALT RESTRAINT

PERMALOC ALUMINUM EDGING, 13505 BARRY STREET HOLLAND, MI, 49424  
 (800) 356-9660 PHONE: (616) 399-9600 fax: (616) 399-9770 WWW.PERMALOC.COM

ARCHITECT NOTE: CHECK OFF APPLICABLE SIZE & FINISH DESIRED

SIZE: ALL 8' (2.44 M) LENGTHS w/ 0.210" (5.33 MM) THICK EXPOSED TOP LIP

1"	X 2.25"	(25 MM	X 57 MM)	MF	BL
1.5"	X 2.25"	(38 MM	X 57 MM)	MF	BL
2"	X 2.25"	(51 MM	X 57 MM)	MF	BL
2.5"	X 2.25"	(64 MM	X 57 MM)	MF	BL
3"	X 3"	(76 MM	X 76 MM)	MF	BL
4"	X 3"	(102 MM	X 76 MM)	MF	BL

### FINISH LEGEND:

(MF) MILL FINISH-NATURAL ALUMINUM  
 (BL) BLACK DURAFLEX-ELECTROSTATICALLY APPLIED BAKED ON PAINT, MEETS AAMA 2603

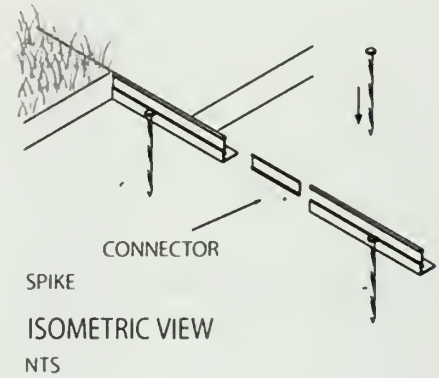

### NOTES:

1. INSTALLATION PER MANUFACTURER'S "INSTALLATION GUIDELINES"
2. 8'-0" (2.44 M) SECTIONS CONNECTED WITH 4" (102 MM) SLIDING CONNECTOR.
3. MAINTAIN 3/8" (9.5 MM) GAP BETWEEN SECTIONS TO ALLOW FOR PRODUCT EXPANSION IN EXTREME TEMPERATURES.
4. CORNERS: NOTCH BASE ONLY AND FORM A CONTINUOUS CORNER.
5. PERMALOC ASPHALTEdge AS MANUFACTURED BY PERMALOC CORPORATION, HOLLAND MI. (800) 356-9660, (616) 399-9600
6. CONTRACTOR'S NOTE: FOR PRODUCT AND PURCHASING INFORMATION VISIT: WWW.PERMALOC.COM

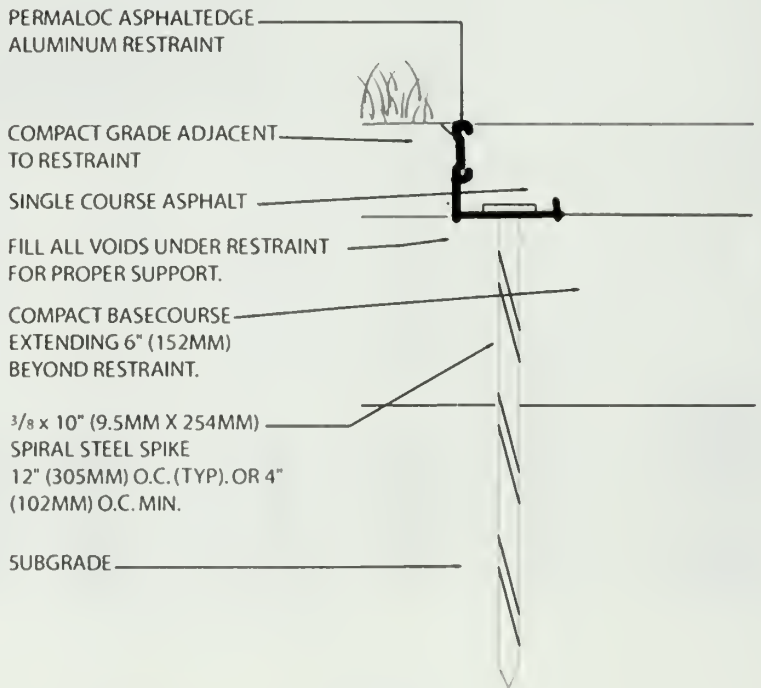

## SINGLE COURSE ASPHALT AND RESTRAINT OVER COMPACTED GRAVEL BASE

SCALE: 3"=1'-0"

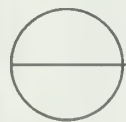

TM



# PERMALOC CLEANLINE

ALUMINUM LANDSCAPE EDGING

PERMALOC CORPORATION, 13505 BARRY STREET HOLLAND, MI, 49424  
(800) 356-9660 PHONE: (616) 399-9600 fax: (616) 399-9770 WWW.PERMALOC.COM

ARCHITECT NOTE: CHECK OFF APPLICABLE SIZE & FINISH DESIRED  
SIZE:

- 1/8" X 3" (3.2MM X 76MM), 0.072" (1.83MM) THICK  
w/ 0.135" (3.43MM) EXPOSED TOP LIP  MF  BL
- 1/8" X 4" (3.2MM X 102MM), 0.072" (1.83MM) THICK  
w/ 0.135" (3.43MM) EXPOSED TOP LIP  MF  BL  GR  BR  BLANO
- 3/16" X 4" (4.8MM X 102MM), 0.116" (2.95MM) THICK  
w/ 0.187" (4.75MM) EXPOSED TOP LIP  MF  BL  GR  BR  BLANO
- 1/8" X 5 1/2" (3.2MM X 140MM), 0.072" (1.82MM) THICK  
w/ 0.135" (3.43MM) EXPOSED TOP LIP  MF  BL  GR  BLANO
- 3/16" X 5 1/2" (4.8MM X 140MM), 0.116" (2.95MM) THICK  
w/ 0.187" (4.75MM) EXPOSED TOP LIP  MF  BL  GR  BLANO

FINISH LEGEND:

- MILL FINISH-NATURAL ALUMINUM
- BLACK DURAFLEX-MEETS AAMA 2603
- GREEN DURAFLEX-MEETS AAMA 2603
- BRONZE DURAFLEX-MEETS AAMA 2603
- BLANO) BLACK ANODIZED - CLASS II, AA-M10C21A33

NOTES:

INSTALL PER MANUFACTURER'S "INSTALLATION GUIDELINES"  
8'-0" (2.44 M) SECTIONS TO INCLUDE (3) 12" (305 MM) ALUMINUM STAKES.  
16'-0" (4.88 M) SECTIONS TO INCLUDE (5) 12" (305 MM) ALUMINUM STAKES.  
CORNERS - CUT BASE EDGING UP HALFWAY AND FORM A CONTINUOUS CORNER.  
PERMALOC CLEANLINE AS MANUFACTURED BY PERMALOC CORPORATION, HOLLAND MI.  
(800) 356-9660,  
(616) 399-9600  
CONTRACTOR'S NOTE: FOR PRODUCT AND PURCHASING INFORMATION VISIT: WWW.PERMALOC.COM

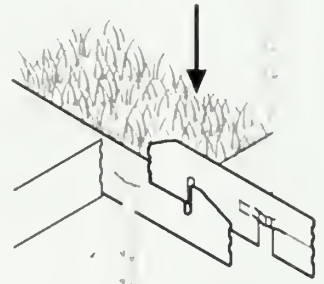

STAKES  
ISOMETRIC VIEW  
NTS

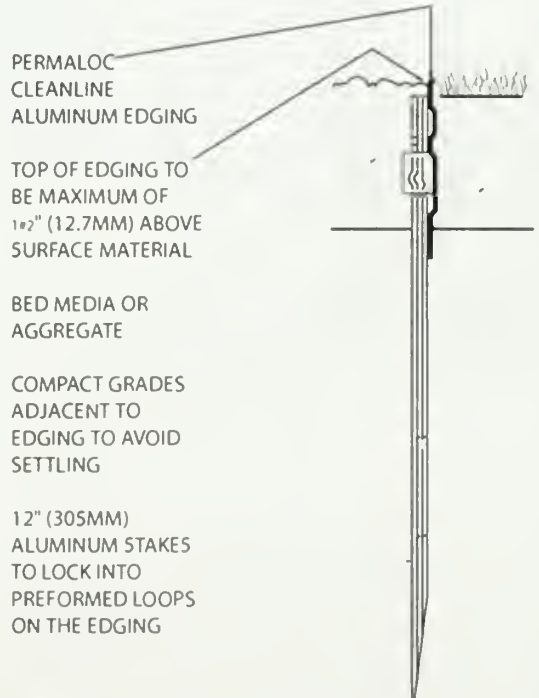

PERMALOC CLEANLINE ALUMINUM EDGING

TOP OF EDGING TO BE MAXIMUM OF 1/2" (12.7MM) ABOVE SURFACE MATERIAL

BED MEDIA OR AGGREGATE

COMPACT GRADES ADJACENT TO EDGING TO AVOID SETTLING

12" (305MM) ALUMINUM STAKES TO LOCK INTO PREFORMED LOOPS ON THE EDGING

## ALUMINUM LANDSCAPE BED EDGING

SCALE: 3"=1'-0"



# Define Your Planting Bed

## Premium Quality!

A premium blend of polyethylene gives EdgePro® lawn edging its superior flexibility, strength and resistance to weathering. Thorough product engineering and quality control assures landscape professionals that every 20-foot length of EdgePro® lawn edging meets the high standards and demands of the industry. EdgePro® comes with a full limited lifetime guarantee. The product will not crack, rot or deteriorate from exposure to weather conditions and will be free of manufacturing defects. EdgePro® lawn edging is manufactured by such rigid standards, it is guaranteed:

- ▶▶ to be uniform in size
- ▶▶ to be shipped flat and straight
- ▶▶ to be consistent from lot to lot
- ▶▶ to have an extra smooth finish
- ▶▶ not to crack or split.



# EdgePro®

“The Professional’s Choice”

## Landscape Edging Accessories

### Custom Landscape Stakes

9.5 inch heavy-duty steel stakes are designed to anchor EdgePro® Landscape Edging in some of the toughest soil conditions.

### Knurled Connectors

Straight, plastic knurled connectors are 7.5 inches in length. They can be used for virtually seamless connections with Landscape Edging.

### Stake Kits

Convenient, ready-made kits consisting of four 9.5 inch heavy-duty steel stakes and one 7.5-inch plastic knurled connector. A minimum of one kit is recommended for each 20-foot section of EdgePro® Landscape Edging.

### 90 Degree Connectors

Corner connections for EdgePro® Professional or EdgePro® Pro-Lip Landscape Edging are made easy with plastic 90-degree connectors.

# CDIMEX

28305 St. Rt. 7, Marietta, OH 45750  
PH: 800-334-3776 FAX: 1-740-374-2700  
[www.edgepro.com](http://www.edgepro.com)



# Landscape Edging

# EdgePro®

# CDIMEX



## Installation Guidelines

- ▶▶ Using a straight edge spade, make a slight trench along bed area where edging is to be installed (trench should be at least 4" deep).
- ▶▶ Place edging in trench with the "V" in the ground, toward the dirt side of he bed (the round top is the only part that should be above the ground).
- ▶▶ Pound stakes, flange pointed downward and towards the grass side, through the edging at a 45 degree angle, just above the V-lip portion. Use stakes at or near curves and spaced evenly throughout.
- ▶▶ Tightly pack soil on the bed side and install ground cover (rock, mulch, etc.) up to the round top of the edging.

EdgePro ProLip

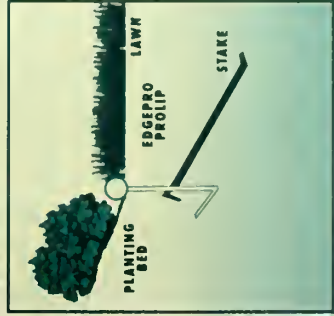

EdgePro Professional

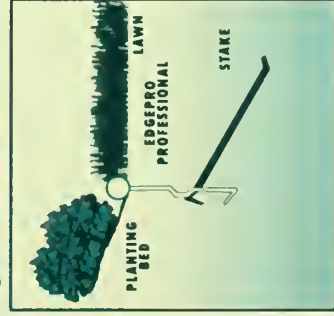

### EdgePro® Professional

EdgePro® Professional is designed with a height from top to bottom of 5.5". The extra-heavy top bead can withstand abuse and sun exposure. Its unique side rib provides enhanced flexibility and workability. Each 20-foot strip weighs 6 lbs. (not including stake kit).



### EdgePro® ProLip

EdgePro® ProLip features a height of 5" from top to bottom. The longer V-Lip helps prevents problems commonly experienced with frost heave. It is manufactured with the same extra-heavy top bead and UV protection as EdgePro® Professional. Each 20-foot strip weighs 6 lbs. (not including stake kit).

## Packaging Configurations



### Bundled 20-foot Strips

EdgePro® Professional and EdgePro® ProLip are available in straight 20-foot strips that are banded 5 per bundle.



### EdgePro® ProLip Boxed Kit

Designed for retailers that prefer to offer the highest quality edging to professional installers and discriminating homeowners. Boxed edging includes one 20-foot strip of EdgePro® ProLip Landscape Edging and a stake kit.



### EdgePro® ProLip Coils

EdgePro® ProLip is also available in 60-foot or 100-foot cone-shaped coils. The stackable coils are perfect for large jobs for homeowners and contractors, minimizing the need to splice connections. Bulk anchoring stakes and connectors are available separately.

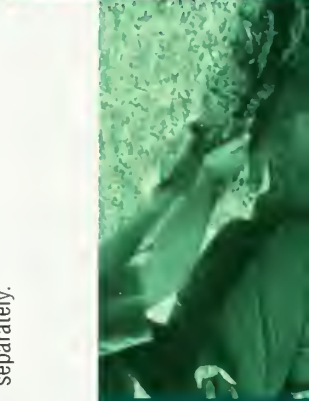

MANUFACTURED BY DIMEX LLC

1.800.EDGEPRO  
1.800.334.3776

www.edgepro.com





SHEET NOTES

1. DIMENSIONS ARE FROM OUTSIDE FACE OF BUILDING, WALLS, OR CURB UNLESS OTHERWISE NOTED, AND ARE TO BE VERIFIED IN THE FIELD PRIOR TO CONSTRUCTION AND MAJOR EXCAVATION. WRITTEN DIMENSIONS TAKE PRECEDENCE OVER SCALING.
2. UNLESS OTHERWISE NOTED, ANGLES TO BE RIGHT ANGLES, ARCS WHICH APPEAR TANGENT AND UNIFORM ARE TO BE TANGENT AND UNIFORM, LINES WHICH APPEAR PARALLEL ARE TO BE PARALLEL, AND ITEMS WHICH APPEAR CENTERED TO BE CENTERED. MAINTAIN LINES TRUE, LEVEL, PLUMB, AND SQUARE.
3. REFER TO GRADING PLANS FOR GRADING AND DRAINAGE STRUCTURES PRIOR TO INSTALLATION OF WALKS, WALLS, FOOTINGS, AND OTHER STRUCTURES.
4. CAREFULLY REVIEW LANDSCAPE IRRIGATION PLANS AND NOTES TO IDENTIFY LOCATIONS WHERE PIPE, SLEEVES, SANDBED OR CONDUIT MUST BE PLACED PRIOR TO INSTALLATION OF PAVING. COORDINATE WITH OTHER TRADES TO INSTALL IRRIGATION PIPE, SLEEVE, SANDBEDDING, OR CONDUIT. SHOULD CONFLICTS ARISE REVIEW WITH CONTRACTING OFFICER FOR RESOLUTION.
5. LAYOUT OF PATHS AND PLANTING AREAS TO BE APPROVED BY THE CONTRACTING OFFICER PRIOR TO INSTALLATION OF PAVING AND EDGING.
6. EXISTING SITE INFORMATION SHOWN HERE COMES FROM SURVEY BY CIVIL ENGINEER AND PROPOSED SITE AND ROOF PLANS BY ARCHITECT. LANDSCAPE ARCHITECT ASSUMES NO RESPONSIBILITY OR LIABILITY FOR COMPLETENESS OR ACCURACY OF PLANS PROVIDED BY OTHERS.
7. REFER TO DEMOLITION PLANS, SHEETS D1.1, D2.4, D2.5, AND D2.6, FOR LANDSCAPE DEMOLITION WORK.
8. REFER TO GRADING AND DRAINAGE PLANS, SHEETS C2.1, C2.2, AND C2.3, FOR LANDSCAPE GRADING AND DRAINAGE WORK.

LEGEND

- — — APPROXIMATE LIMIT OF LANDSCAPE WORK, EXCEPT FOR MODIFICATIONS TO EXISTING IRRIGATION SYSTEM, SOME OF WHICH ARE LOCATED OUTSIDE LIMIT LINE SHOWN.
- - - SAWCUT LINE - SEE DEMOLITION PLANS.
-  **7** (L4.1) AC PATH PAVING
- P.A. PLANTING AREA

KEYPLAN

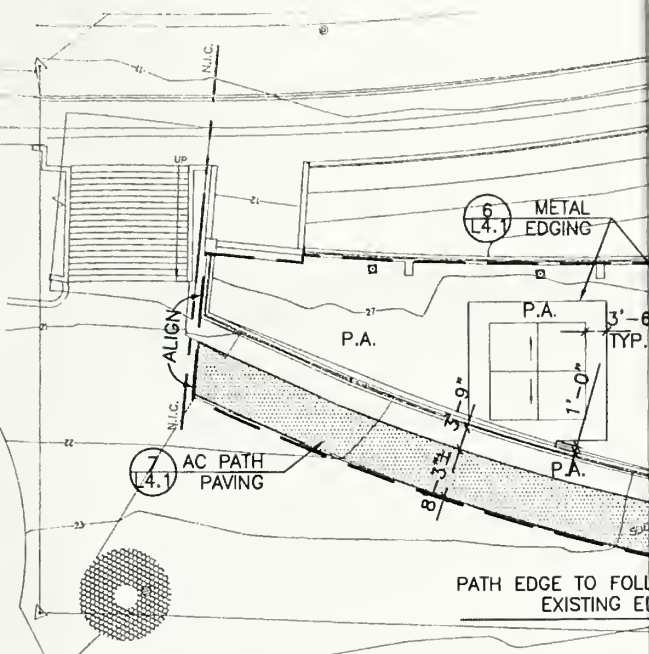
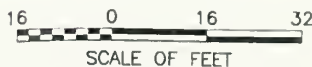

**1** (L1.0) LANDSCAPE LAYOUT - WEST AREA

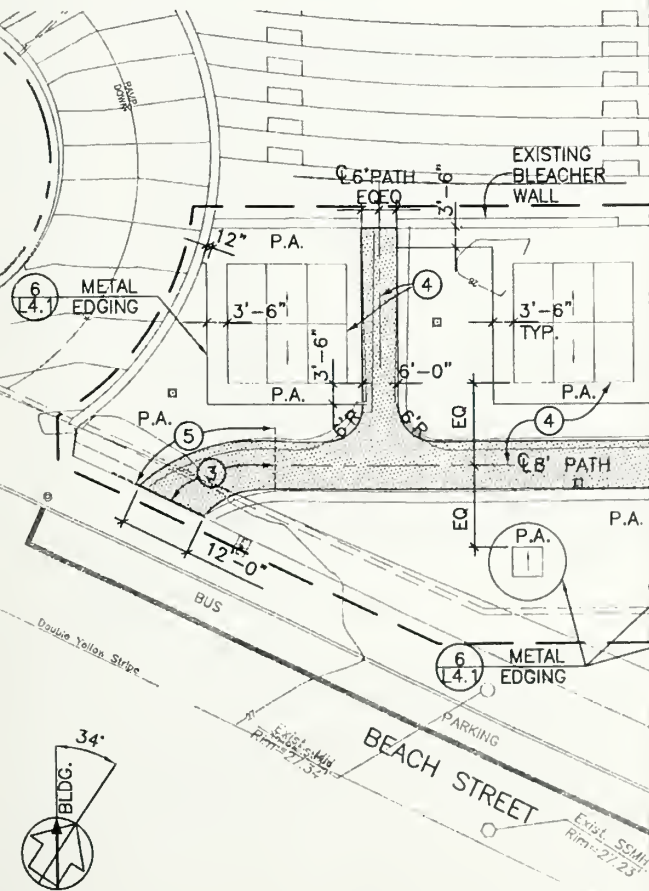

**2** (L1.0) LANDSCAPE LAYOUT - CENTER AREA

JOB SHEET NO.

L1.0

TITLE OF SHEET  
**LANDSCAPE LAYOUT PLAN**

SAN FRANCISCO MARITIME N.H.P.  
AQUATIC PARK NHL DISTRICT

DRAWING NO.  
**350**  
**25011A**  
PMIS/PKG NO.  
102086  
SHEET



# Appendix E

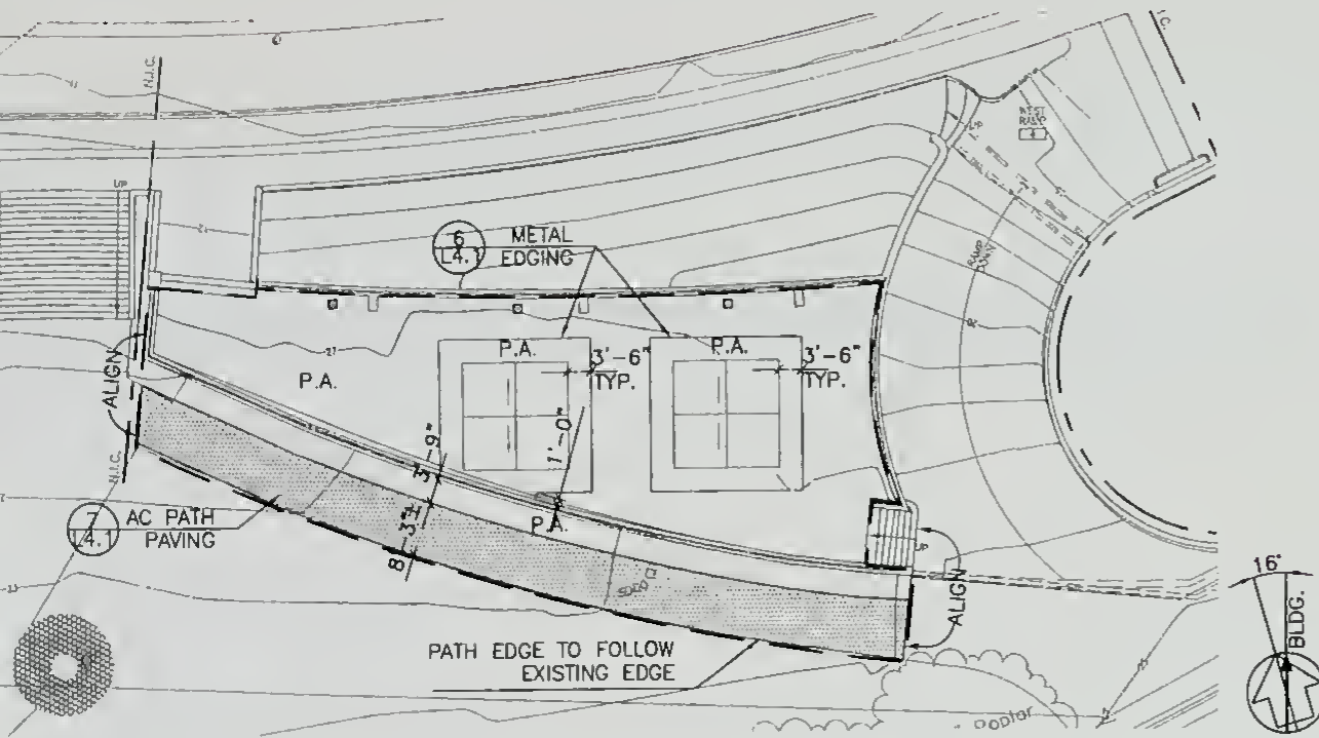

1 LANDSCAPE LAYOUT - WEST AREA  
L1.0

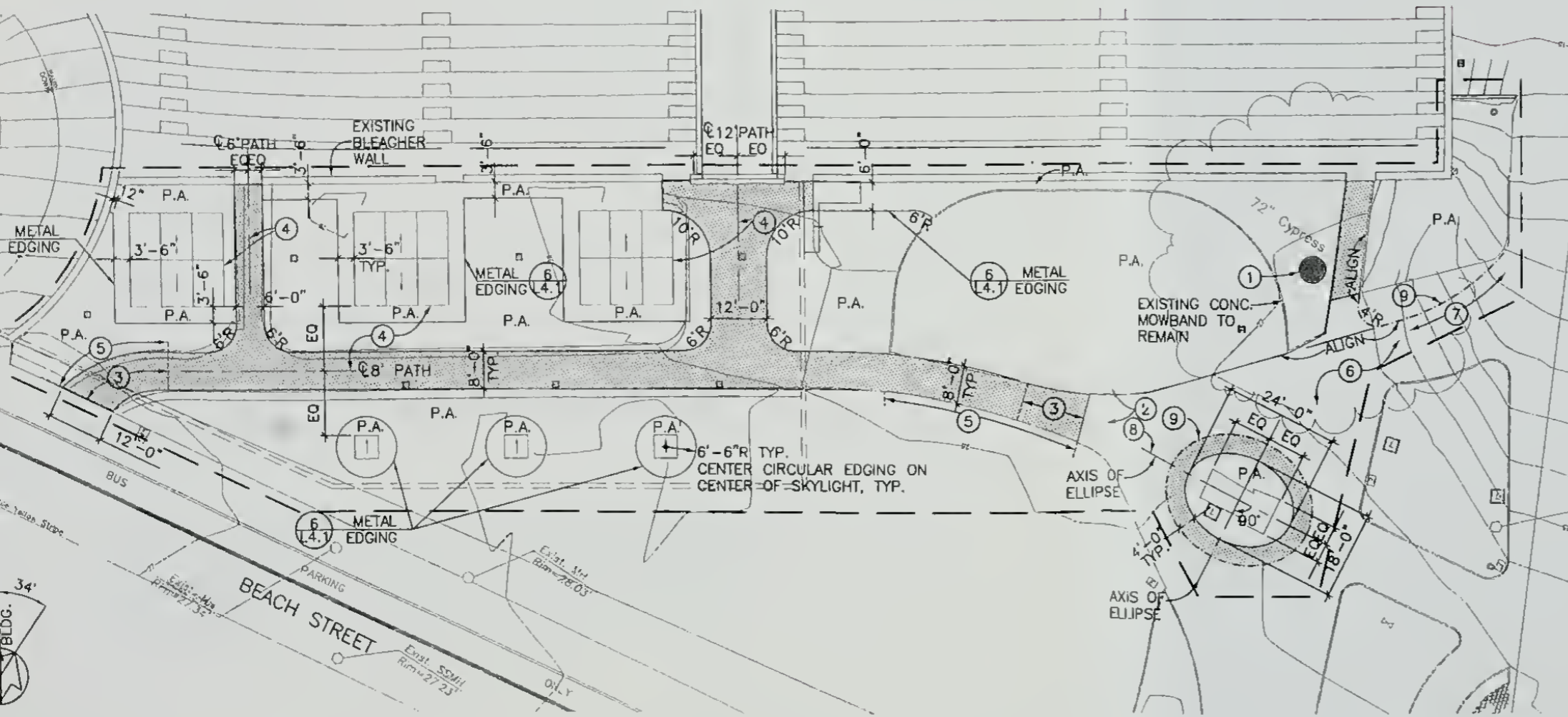

2 LANDSCAPE LAYOUT - CENTER AND EAST AREA  
L1.0

## KEY NOTES

- 1 PROTECT EXISTING CYPRESS TREE AS SPECIFIED.
- 2 PROTECT EXISTING ROCK AND HISTORICAL MARKER PLAQUES.
- 3 TRANSITION BETWEEN 8-FOOT PATH WIDTH AND EXISTING PATH WIDTH.
- 4 ALIGN CENTERLINE PARALLEL TO SKYLIGHT EDGE INDICATED.
- 5 PATH EDGE TO FOLLOW EXISTING ALIGNMENT.
- 6 EXISTING AC PAVEMENT TO REMAIN.
- 7 SMOOTH CURVE, TANGENT AT BOTH ENDS.
- 8 ALIGN CENTERLINE PARALLEL WITH CENTERLINE OF TOWER CONCRETE PAD.
- 9 SAWCUT LINE - SEE DEMOLITION PLANS.

## SHEET NOTES

1. DIMENSIONS ARE FROM OUTSIDE FACE OF BUILDING, WALLS, OR CURB UNLESS OTHERWISE NOTED, AND ARE TO BE VERIFIED IN THE FIELD PRIOR TO CONSTRUCTION AND MAJOR EXCAVATION. WRITTEN DIMENSIONS TAKE PRECEDENCE OVER SCALING.
2. UNLESS OTHERWISE NOTED, ANGLES TO BE RIGHT ANGLES, ARCS WHICH APPEAR TANGENT AND UNIFORM ARE TO BE TANGENT AND UNIFORM, LINES WHICH APPEAR PARALLEL ARE TO BE PARALLEL, AND ITEMS WHICH APPEAR CENTERED TO BE CENTERED. MAINTAIN LINES TRUE, LEVEL, PLUMB, AND SQUARE.
3. REFER TO GRADING PLANS FOR GRADING AND DRAINAGE STRUCTURES PRIOR TO INSTALLATION OF WALKS, WALLS, FOOTINGS, AND OTHER STRUCTURES.
4. CAREFULLY REVIEW LANDSCAPE IRRIGATION PLANS AND NOTES TO IDENTIFY LOCATIONS WHERE PIPE, SLEEVES, SANDBED OR CONDUIT MUST BE PLACED PRIOR TO INSTALLATION OF PAVING. COORDINATE WITH OTHER TRADES TO INSTALL IRRIGATION PIPE, SLEEVE, SANDBEDDING, OR CONDUIT. SHOULD CONFLICTS ARISE REVIEW WITH CONTRACTING OFFICER FOR RESOLUTION.
5. LAYOUT OF PATHS AND PLANTING AREAS TO BE APPROVED BY THE CONTRACTING OFFICER PRIOR TO INSTALLATION OF PAVING AND EDGING.
6. EXISTING SITE INFORMATION SHOWN HERE COMES FROM SURVEY BY CIVIL ENGINEER AND PROPOSED SITE AND ROOF PLANS BY ARCHITECT. LANDSCAPE ARCHITECT ASSUMES NO RESPONSIBILITY OR LIABILITY FOR COMPLETENESS OR ACCURACY OF PLANS PROVIDED BY OTHERS.
7. REFER TO DEMOLITION PLANS, SHEETS D1.1, D2.4, D2.5, AND D2.6, FOR LANDSCAPE DEMOLITION WORK.
8. REFER TO GRADING AND DRAINAGE PLANS, SHEETS C2.1, C2.2, AND C2.3, FOR LANDSCAPE GRADING AND DRAINAGE WORK.

## LEGEND

- APPROXIMATE LIMIT OF LANDSCAPE WORK, EXCEPT FOR MODIFICATIONS TO EXISTING IRRIGATION SYSTEM, SOME OF WHICH ARE LOCATED OUTSIDE LIMIT LINE SHOWN.
- SAWCUT LINE - SEE DEMOLITION PLANS.
- [Hatched Box] (L4.1) AC PATH PAVING
- P.A. PLANTING AREA

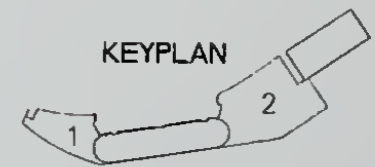

16 0 16 32  
SCALE OF FEET

DESIGNED: JCD @ADD JS, JBS TECH. REVIEW:	SUB SHEET NO.  <b>L1.0</b>	TITLE OF SHEET <b>LANDSCAPE LAYOUT PLAN</b>	DRAWING NO. <b>350</b> <b>25011A</b>
DATE: 1/3/DR		SAN FRANCISCO MARITIME N.H.P. AQUATIC PARK NHL DISTRICT	PMIS/PKG NO. 102D86 SHEET

APPENDIX F: AQUATIC PARK DRAWINGS ON FILE, NATIONAL PARK SERVICE,  
PACIFIC WEST REGION, OAKLAND, CALIFORNIA

COMPILED BY DENISE BRADLEY

Year	Title	Notes
1913-1932	<p>Punnett, John. M., C. E. 1913. Plan of Proposed Aquatic Park San Francisco, Cal. Prepared for Aquatic Park Committee By John M. Punnett, C. E., June 1913. SAFR HDC 555.B5.15-3.</p> <p>1920 Plan of Proposed Aquatic Park San Francisco, Cal. Prepared for Aquatic Park Committee By John M. Punnett, C. E., January 1920. SAFR HDC 555.B5.15-3.</p> <p>1923 Plan of Proposed Aquatic Park San Francisco, Cal. Prepared for Aquatic Park Committee By John M. Punnett, C. E., Feb. 1923. SAFR HDC 555.B5.15-3.</p> <p>1925 Plan of Proposed Aquatic Park San Francisco, Cal. Prepared for Aquatic Park Committee By John M. Punnett, C. E. [February 1925]. SAFR HDC 555.B5.15-3.</p> <p>1928 Plan of Proposed Aquatic Park San Francisco, Cal. Prepared for Aquatic Park Committee By John M. Punnett, C. E., September 1928. SAFR HDC 555.B5.15-3.</p> <p>1932 Plan of Proposed Aquatic Park San Francisco, Cal. Prepared for Aquatic Park Committee By John M. Punnett, C. E., Feb. 1932. SAFR HDC 555.B5.15-3.</p> <p>Punnett, Perez &amp; Hutchinson (Civil Engineers).</p> <p>1932a Board of Park Commissioners Plan of Aquatic Park, San Francisco, Cal. Punnett, Perez &amp; Hutchinson - Civil Engineers, February 1932. SAFR Museum Plans Collections HDC 555, B5. 19-2.</p> <p>1932b Board of Park Commissioners Plan of Aquatic Park, San Francisco, Cal. Punnett, Perez &amp; Hutchinson - Civil Engineers, October 6, 1932. SAFR Museum Plans Collections HDC 555, B5. 15-8.</p>	<p>Show ideas for layout of park prior to WPA project.</p> <p>Shows Punnett involvement for 23 years before WPA project</p>
1925	<p>Bakewell &amp; Brown et al.</p> <p>1925 Plans for Improvement of the Aquatic Park. Prepared for the city and County of San Francisco, Board of Park Commissioners. Bakewell &amp; Brown and John A. Baur, Associated Architects and Frank G. White and Harry E. Squire, Construction Engineers. August 1925. SAFR HDC. 555. drw 5.19-1.</p>	<p>Curved form of the Municipal Pier</p>



Year	Title	Notes
1933	<p>Punnett, Perez &amp; Hutchinson (Civil Engineers).</p> <p>1933 Plan of Concrete Parapet, Curb &amp; Seat to be constructed on Recreation Pier, Aquatic Park. Prepared for the City and County of San Francisco, Board of Park Commissioners, 29 August 1933. SAFR HDC.555.drw B5.19-5.</p>	Design of curb, parapet, bench for the Municipal Pier
1936-1937	<p>[City and County of] San Francisco, Office of the Board of Park Commissioners.</p> <p>Ca. 1936-37 Aquatic Park, Bath House Building, Plot Plan, WPA Project No. 2175, Sheet A-0, [no date.] SAFR Museum Plans Collections, HDC 555, Folder B5-11-1.</p>	Shows ideas for the layout of site at beginning of WPA project
1937	<p>[City and County of] San Francisco, Office of the Board of Park Commissioners.</p> <p>1937a Landscape Plan, Aquatic Park, 23 February 1937. Prepared Under the Supervision of T. B. Grabow, Asst. Supt. Of Parks. Sheets 1, of 4. SAFR Museum Plans Collections/SAFR CLI Plan File.</p> <p>1937b Landscape Plan, Aquatic Park, 23 February 1937. Prepared Under the Supervision of T. B. Grabow, Asst. Supt. Of Parks. Sheets 2 of 4. SAFR Museum Plans Collections/SAFR CLI Plan File.</p> <p>1937c Landscape Plan, Aquatic Park, 23 February 1937. Prepared Under the Supervision of T. B. Grabow, Asst. Supt. Of Parks. Sheets 4 of 4. SAFR Museum Plans Collections</p>	Shows city's planting plan
1938	<p>Punnett, John. M., C. E.</p> <p>1938 Board of Park Commissioners Plan of Aquatic Park, San Francisco, Cal. Prepared by John M. Punnett – Civil Engineer, Jan. 10, 1938. SAFR Museum Plans Collections HDC 555, B5. 15-8.</p>	Shows evolution of ideas for layout of site from 1936 to 1938. Shows 1937 planting plan ideas.
1939	<p>[City and County of] San Francisco, Office of the Board of Park Commissioners.</p> <p>1939 Underground Sprinkling System, Aquatic Park. 19 September 1939. SAFR Museum Plans Collections HDC 555, Folder B5.15-6.</p>	Shows sidewalk connections and planting bed layout around west convenience station.

Year	Title	Notes
1939-1941	<p>[City and County ] San Francisco, Office of the Board of Park Commissioners.</p> <p>Ca. 1939-41 Plan of Auto Parking, Bocci [sic] Courts &amp; Path Arrangement, Scheme E, Aquatic Park, [no date]. SAFR Museum Plans Collections HDC 555, Folder B5.15-6.</p> <p>Ca. 1939-41 Details of Typical Boccie [sic] Court for Aquatic park, prepared under supervision of T. M. Grabow, Asst. Supt. of Parks, [no date]. SAFR Museum Plans Collections HDC 555, Folder B5.15-6.</p> <p>Ca. 1940 General Plan of Auto Parking Area &amp; Park, Aquatic Park, [undated]. (Revised). SAFR Museum Plans Collections HDC 555, B5. 15-6.</p> <p>1941a General Plan of Auto Parking Area &amp; Park, Aquatic Park, Division of Engineering, Board of Park Commissioners, San Francisco, Aug 27, 1941. (2nd Revision). SAFR Museum Plans Collections HDC 555, B5. 15-6.</p> <p>[City and County of] San Francisco, Board of Park Commissioners, Division of Engineering.</p> <p>1940a General Plan of Auto Parking Area &amp; Park, Aquatic Park, Division of Engineering, Board of Park Commissioners, San Francisco, April 1, 1940. Sheet No. 1. SAFR Museum Plans Collections HDC 555, B5. 15-6.</p> <p>1940b Details of Boccie Courts at Auto Parking Area and Park at Aquatic Park, Division of Engineering, Board of Park Commissioners, San Francisco, April 22, 1940. SAFR Museum Plans Collections HDC 555, B5. 15-6.</p> <p>1940c Enlarged Working Details for Auto Parking Area and Park at Aquatic Park, Division of Engineering, Board of Park Commissioners, San Francisco, May 2, 1940. Sheet No. 3. SAFR Museum Plans Collections HDC 555, B5. 15-6.</p> <p>1940d Proposed Drainage System for Auto Parking Area and Park at Aquatic Park, Division of Engineering, Board of Park Commissioners, San Francisco, June 10, 1940. SAFR Museum Plans Collections HDC 555, B5. 15-6.</p>	<p>Schematic ideas for Block 9 (Victorian Park) by city during period of sign.</p>
1941	<p>[City and County of] San Francisco, Office of the Board of Park Commissioners.</p> <p>1941b Preliminary Plan of Mother's &amp; Children's Play Area &amp; Proposed Improvements At Aquatic Park. Approved 28 August 1941. SAFR Museum Plans Collections HDC 555, B5. 15-7.</p>	<p>Shows city's schematic plans for bocce ball area during period. Compare to ideas in 1937 plan</p>



Year	Title	Notes
1943	<p>[United States, Army, Fort Mason], Post Engineers Office.</p> <p>1943 Fort Mason, S.F. Calif. Post Map, Revised October 1st 1943. (included in FOMA Officers Club HSR).</p>	Shows location of 6-car garage in area west of Van Ness.
1944	<p>U.S. Engineer Office, San Francisco, California</p> <p>1944 Sheet 1: Location Plan, Small Boat Mooring, San Francisco Port of Embarkation, Aquatic Park, Fort Mason, California, March 27, 1944. SAFR HDC.555.drw B5.19-3.</p>	Shows location of sea scout
1952	<p>Punnett, Perez &amp; Hutchinson (Civil Engineers).</p> <p>1952 Topographic Survey of Portion of Aquatic Park for Recreation and Park Department San Francisco, Calif. 26 November 1952. SAFR Museum Plans Collections HDC 555, B5. 16-1/.</p>	Shows concrete as material for Promenade (upper walkway) on west end not asphalt.
1953	<p>City and County of San Francisco, Recreation and Park Department.</p> <p>Aquatic Park Lagoon, Soundings Vicinity of Sea Scout Wharf. Sheet 1 of 1. 25 February 1953. SAFR Museum Plans Collections HDC 555, B5. 16-1.</p>	
1956	<p>Punnett, Perez &amp; Hutchinson (Civil Engineers).</p> <p>1956 [Topographic Survey Aquatic Park] Surveyed for Recreation and Park Department San Francisco, Calif. 29 June 1956. SAFR Museum Plans Collections HDC 555, B5. 16-1.</p>	
1958-1959	<p>California, Department of Natural Resources, Division of Beaches &amp; Parks.</p> <p>1958 <i>Part of the Master Plan, Initial Development Plan, San Francisco Maritime State Historical Monument</i>, Sheet 2 of 6, Designed by E. U. B 3-18-58. SAFR, HDC 555.drw B5.16-5 “SFMSHP Master Plan 1958.”</p> <p>1959 <i>San Francisco Maritime State Historical Monument, Preliminary Development Plan, Proposed Block 9 Development</i>, Sheet 1 of 1 (Designed 1-20-59/Reviewed 2-2-59). SAFR, HDC 555.drw B5.16-5 “SFMSHP Master Plan 1958.”</p> <p>1959 <i>San Francisco Maritime State Historical Monument, Preliminary Development Plan</i>, Sheet 1 of 1 (Designed 1-20-59/Reviewed 2-2-59). SAFR, HDC 555.drw B5.16-7.</p>	Shows evolution of plan for Victorian Park area

Year	Title	Notes
1960	<p>California, Department of Natural Resources, Division of Beaches &amp; Parks.</p> <p>1960 <i>San Francisco Maritime State Historical Monument General Development Sheet</i>. (Designed by Division Staff, July 1960). SAFR Karl Kortum Collection. HCD 1084, Box 5, Series 2, Subseries 2, File Unit 37 "Victorian Park (Lamps, Benches, Ironwork) 1959-1991.</p>	<p>This plan appears very similar to final 1961 plan.</p>
1961	<p>California, Department of Public Works, Division of Architecture.</p> <p>Maritime Plaza (Victorian Park). Sheet 1: Existing Conditions; Sheet 2: Grading Plan; Sheet 3: Drainage and Electrical; Sheet 4: Paving and Layout; Sheet 5: Gas Lighting Layout; Sheet 6: Sprinkler Irrigation Plan; Sheet 7: Planting Plan; Sheets 8 and 9: Construction Details; Sheet 10: Sprinkler Irrigation Details; Sheet 11: Cable Car Waiting Station. June 1961. SAFR; HDC 555.drw B5-17-2 "Aquatic Park 1961, California Department of Public Works series."</p>	<p>Final plan for Victorian Park Only have Sheet 7: planting plan in office</p>
1961	<p>Quesada, George, AIA</p> <p>1961 Facilities Development, Bocce Ball Courts Phase II, Southwest Area, Aquatic Park, Beach St. &amp; Van Ness Ave., San Francisco, 3 Sheets. Prepared for Recreation &amp; Park Department, City &amp; County of San Francisco, Approved: Raymond S. Kimbell, General Manager, 2/15/61. SAFR Museum Plans Collections HDC 555, B5. 17-1.</p>	<p>Design for original bocce ball area and overhead structure</p>
1967	<p>City and County of San Francisco, Department of Public Works, Bureau of Architecture 1967 Aquatic Park, Memorial Drinking Fountain, Plan Elevations &amp; Details, Sheet A-1, 3/24/67. SAFR Museum Plans Collections, HDC 555, B5.17-6</p>	<p>Plan for commemorative fountain at bocce ball</p>
1969	<p>City and County of San Francisco, Real Estate Department.</p> <p>1969 Aquatic Park – Maritime Museum Area, San Francisco, Drawing No. 1, Dec. 1969. SAFR Museum Plans Collections, HDC 555, B5.17-6.</p>	
1975	<p>National Park Service, Golden Gate National Recreation Area, Division of Maintenance.</p> <p>1975 Planting &amp; Irrigation Development Plan, Van Ness Opposite Aquatic Park, Golden Gate National Recreation Area. Sheets 1 and 2 of 2. June 1975. Copy in PWR Oakland, SAFR CLI Plan File.</p>	<p>Shows plan for pocket park on west side of Van Ness</p>
1982	<p>Painter, Michael &amp; Associates.</p> <p>1982 <i>Schematic Design, Victoria [sic] Park, San Francisco, California</i>. 11 February 1982. (found in SAFR CLI Plan File.)</p>	<p>1982 redesign of Victorian Park area</p>

Year	Title	Notes
1982	<p>City and County of San Francisco, Public Utilities Commission, Utilities Engineering Bureau.</p> <p>1982 Rehabilitation of Cable Car Trackway. Victorian Park Terminal Landscape Plan. 11 November 1982. Prepared by Michael Painter &amp; Associates. GOGA.</p>	1982 redesign of Victorian Park area
Ca. 1994	<p>National Park Service, Golden Gate National Recreation Area, Division of Maintenance.</p> <p>ca. 1994 No date [Bocce Ball Area], Aquatic Park, Golden Gate National Recreation Area. Sheets 1 of 2. No Date. GOGA Office of Resource Management, Building 201, War Room.</p>	Shows NPS ideas for bocce ball area at time that roof to bocce overhead structure replaced.



As the nation's principal conservation agency, the Department of the Interior has the responsibility for most of our nationally owned public lands and natural resources. This includes fostering sound use of our land and water resources; protecting our fish, wildlife, and biological diversity; preserving the environmental and cultural values of our national parks and historical places; and providing for the enjoyment of life through outdoor recreation. The department assesses our energy and mineral resources and works to ensure that their development is in the best interests of all our people by encouraging stewardship and citizen participation in their care. The department also has a major responsibility for American Indian reservation communities and for people who live in island territories under U.S. administration.



