



3 1604 003 939 339

PUBLIC DOCUMENTS  
DEPOSITORY ITEM

NOV 27 1990

CLEMSON  
LIBRARY



Historic Furnishings Report

**LINCOLN HOME**

National Historic Site / Illinois

Approved: Regional Director, Midwest Region

November 1, 1983

HISTORIC FURNISHINGS REPORT  
Sections A through E

**THE LINCOLN HOME**

Lincoln Home National Historic Site

Springfield, Illinois

by

Katherine B. Menz

1983  
Harpers Ferry Center  
National Park Service  
U. S. Department of the Interior



Digitized by the Internet Archive  
in 2012 with funding from  
LYRASIS Members and Sloan Foundation

<http://archive.org/details/historicfurnishi00menz>



## ACKNOWLEDGMENTS

Many people assisted with the research and preparation of this report.

I wish to specially thank the Lincoln Home staff, in particular Superintendent Albert Banton, Historian George Painter, Interpretive Specialist Robert F. Holmes, and Museum Aid Paul Sullivan for their guidance and assistance on site.

This study followed the National Park Service report, The Historic Structure Report: Lincoln Home National Historic Site (Denver Service Center, July 1973), prepared by Edwin C. Bearss. The furnishings information found in that report has been incorporated into this furnishing study. Particular thanks are also due to Edwin C. Bearss for sharing his extensive knowledge of Lincoln historical material and his suggestions for possible sources of information.

Another person whose research has been relied upon in this report is the late Richard Hagen, who served as Historical Consultant to the State of Illinois during the 1954-1955 restoration and refurnishing of the Lincoln Home. Mr. Hagen's work in tracking down original Lincoln artifacts has been incorporated into this study.

I wish to specially acknowledge James Hickey, Curator of the Lincoln Collection, Illinois State Historical Library. Hickey located and made available to me the Lincoln Home Files and answered innumerable questions. His extensive knowledge of Lincoln artifacts and Lincoln collectors was an important source of information for this report.

Many thanks are due to Nancy Konstantinidis, who typed several drafts of this study, and to Vi Earnst, a Volunteer in the Park, whose furnishing research projects, work on the kitchen and dining room plans, and assistance with the final draft were invaluable.

The section entitled, "Special Installation, Maintenance and Protection Recommendations," was prepared by Diana Pardue of the Curatorial Services Unit at Harpers Ferry.

TABLE OF CONTENTS

ACKNOWLEDGMENTS..... iii

TABLE OF CONTENTS..... v

LIST OF ILLUSTRATIONS..... x

ADMINISTRATIVE DATA..... xi

NAME, NUMBER, AND CLASSIFICATION OF STRUCTURE..... xi

LOCATION AND PROPOSED USE OF STRUCTURE..... xi

PLANNING AND OTHER DOCUMENTS RELATING TO FURNISHING THE STRUCTURE.. xi

SECTION A: DEFINITION OF INTERPRETIVE OBJECTIVES..... 1

SECTION B: OPERATING PLAN..... 3

HISTORICAL DATA..... 5

SECTION C: ANALYSIS OF HISTORICAL OCCUPANCY..... 5

    FOOTNOTES TO SECTION C..... 26

SECTION D: EVIDENCE OF ORIGINAL FURNISHINGS..... 33

    INTRODUCTION..... 33

    CONTEMPORARY ACCOUNTS..... 33

    THE LINCOLNS' 1861 SALE OF HOUSEHOLD FURNISHINGS..... 45

    PICTORIAL EVIDENCE OF FIRST FLOOR FURNISHINGS..... 46

    RECORDED FURNISHINGS - FIRST FLOOR..... 48

LINCOLN HOME FURNISHINGS WITH STRONG DOCUMENTATION.....	48
BOOKS:.....	48
CHAIRS:.....	53
CLOCKS:.....	60
HALL STAND:.....	62
LIGHTING DEVICES:.....	63
MIRRORS:.....	65
SECRETARY-DESKS:.....	66
SEWING BASKETS:.....	67
SOFAS:.....	68
TABLES:.....	72
ARCHEOLOGICAL EVIDENCE:.....	77
FURNISHINGS ASSOCIATED WITH LINCOLN BUT NOT WELL DOCUMENTED.....	79
CHAIRS:.....	79
FOOTSTOOLS:.....	86
LAMPS:.....	87
MIRRORS:.....	87
MUSIC BOXES:.....	88
PEDESTAL STANDS:.....	89
SECRETARIES AND DESKS:.....	90
SOFAS:.....	92
STEREOSCOPE:.....	93
TABLES:.....	94
WHATNOTS:.....	96
ACCESSORY FURNISHINGS.....	98
SPRINGFIELD STORE ACCOUNTS:.....	98
BASKET OF APPLES:.....	100
VOLK BUST OF LINCOLN:.....	100
DINNERWARE, ETC.:.....	101
LINCOLN FAMILY ARTIFACTS IN OTHER COLLECTIONS.....	104
RECORDED KITCHEN FURNISHINGS.....	109
STOVE:.....	109
CUPBOARD:.....	110
KITCHEN PURCHASES:.....	112
RECORDED FURNISHINGS - SECOND FLOOR.....	119
PICTORIAL:.....	119
BEDS:.....	120
COMMDES AND DAYBEDS:.....	125
BLANKET CHESTS:.....	127

BUREAUS:.....	128
CHILDREN'S FURNITURE:.....	133
DESKS:.....	136
MIRRORS:.....	136
WARDROBES:.....	137
WASHSTAND, TOILET SET, QUILT, PICTURE, ETC. AND MISCELLANEOUS ITEMS:.....	138
VANITY:.....	141
DRUGS AND TOILETRIES:.....	142
FABRIC PURCHASES.....	144
FLOOR COVERINGS.....	145
WALLPAPER.....	147
FOOTNOTES TO SECTION D.....	150
<u>THE PLAN</u> .....	161
SECTION E: RECOMMENDED FURNISHINGS.....	161
PARLORS: INTRODUCTION.....	164
FRONT PARLOR: ROOM A.....	165
REAR PARLOR: ROOM B.....	181
SITTING ROOM: INTRODUCTION.....	186
SITTING ROOM: ROOM C.....	187
DINING ROOM: INTRODUCTION.....	195
DINING ROOM: ROOM D.....	197
KITCHEN-PORCH-STOREROOM: INTRODUCTION.....	207
KITCHEN-PORCH-STOREROOM: ROOMS E.....	208
FIRST FLOOR HALL: ROOM F.....	230
WINDOW HANGINGS: FIRST FLOOR: ROOMS A-D.....	233

FLOOR COVERINGS AND WALLPAPER: FIRST FLOOR: ROOMS A-D, F.....	234
BEDROOMS: INTRODUCTION.....	240
MR. LINCOLN'S BEDROOM: ROOM G.....	243
GUEST ROOM: ROOM H.....	257
MRS. LINCOLN'S BEDROOM: ROOM I.....	265
BOYS' ROOM: ROOM J.....	277
MAID'S ROOM: INTRODUCTION.....	284
MAID'S ROOM: ROOM K.....	285
HALLWAY: SECOND FLOOR: ROOM L.....	292
WINDOW HANGINGS: SECOND FLOOR: ROOMS G-L.....	295
FLOOR COVERINGS AND WALLPAPER: SECOND FLOOR: ROOMS G-L.....	296
FOOTNOTES TO SECTION E.....	300
SUMMARY OF FURNISHINGS AND COST ESTIMATES.....	305
(Window hangings, floor coverings, and wallpaper are listed under their respective rooms.)	
FRONT PARLOR: ROOM A.....	305
REAR PARLOR: ROOM B.....	309
SITTING ROOM: ROOM C.....	311
DINING ROOM: ROOM D.....	314
KITCHEN-PORCH-STOREROOM: ROOMS E.....	317
FIRST FLOOR HALL: ROOM F.....	320
MR. LINCOLN'S BEDROOM: ROOM G.....	321
GUEST ROOM: ROOM H.....	325
MRS. LINCOLN'S BEDROOM: ROOM I.....	328
BOYS' ROOM: ROOM J.....	331
MAID'S ROOM: ROOM K.....	334
SECOND FLOOR HALL: ROOM L.....	335
FLOOR PLANS.....	337

SPECIAL INSTALLATION, MAINTENANCE AND PROTECTION RECOMMENDATIONS.....	351
<u>LIST OF APPENDICES.....</u>	377
<u>SELECTED BIBLIOGRAPHY.....</u>	411
<u>ILLUSTRATIONS.....</u>	423

## LIST OF ILLUSTRATIONS

### Plates

Following Page 423

- I Front Parlor from Frank Leslie's Illustrated Newspaper,  
March 9, 1861.
- II Back Parlor from Frank Leslie's Illustrated Newspaper,  
March 9, 1861.
- III The Sitting Room from Frank Leslie's Illustrated  
Newspaper, March 9, 1861.
- IV Parlors draped for Lincoln's Funeral, ca. 1865,  
attributed to Alfred Waud, Waud Collection,  
LC-USZ62-68106, Division of Prints and Photo-  
graphs, Library of Congress, Washington, D. C.
- V Unidentified room, possibly South Front Bedroom,  
ca. 1865, attributed to Alfred Waud, Waud Collec-  
tion, LC-USZ62-68105, Division of Prints and  
Photographs, Library of Congress, Washington, D. C.
- VI Unidentified room, possibly Lincoln's Bedroom,  
ca. 1865, attributed to Alfred Waud, Waud Collec-  
tion, LC-USZ62-68104, Division of Prints and  
Photographs, Library of Congress, Washington, D. C.
- VII Globe Tavern, ca. 1865, attributed to Alfred Waud,  
Waud Collection, LC-USZ62-68107, Division of  
Prints and Photographs, Library of Congress,  
Washington, D. C.
- VIII Sofa, Accession No. 1920.246, Chicago Historical  
Society, Chicago, Illinois.
- IX Mirror, Accession No. 1960.100, Chicago Historical  
Society, Chicago, Illinois.



## ADMINISTRATIVE DATA

### NAME, NUMBER, AND CLASSIFICATION OF STRUCTURE

The Lincoln Home, Building No. 1, First Order of Significance.

### LOCATION AND PROPOSED USE OF STRUCTURE

The Lincoln Home is located on Eighth Street, Springfield, Illinois. It is furnished and interpreted to "appear precisely as it did on the day Lincoln left to take up duties of the presidency in Washington" (Interpretive Prospectus, 1976, p. 10).

### PLANNING AND OTHER DOCUMENTS RELATING TO FURNISHING THE STRUCTURE

Bearss, Edwin C. Historic Structures Report: Lincoln Home National Historic Site. Denver, Colorado: Denver Service Center, National Park Service, 1973.

Ryan, James. Final Interpretive Prospectus: Lincoln Home National Historic Site. Harpers Ferry, West Virginia: Harpers Ferry Center, National Park Service, 1976.



## SECTION A: DEFINITION OF INTERPRETIVE OBJECTIVES

The fundamental interpretive objective of the Lincoln Home National Historic Site is to illuminate the life and character of Abraham Lincoln during the seventeen years that he lived in the Home, rather than to represent the everyday life of the period or to recapture the setting of a single event. More specifically, the Interpretive Prospectus (October 1976) for the Lincoln Home National Historic Site identifies four Interpretive Objectives for the area:

1. To interpret the developing career of Abraham Lincoln and the events associated with that career while he lived in this house and in the Springfield community.
2. To interpret events in the life of Abraham Lincoln in this house where he lived primarily as a father, husband, citizen, and neighbor.
3. To present the Lincoln Home, the contemporary neighborhood around it, and the related historical remains in the Springfield community in such a way as to enable visitors to understand the environment of which Mr. Lincoln was a part for the 17 years that took him from the beginnings of a law practice here to the presidency.

4. To interpret Lincoln's social and political ideas, many of which were formed while he lived in this house in Springfield, and which were implemented as national policy during his presidency and left to us -- a complex legacy of both national and individual ideals to which we still aspire and toward the fulfillment of which we continue to work.

The furnishing arrangements of the Lincoln Home will play an important role in contributing to the achievement of these Interpretive Objectives. The furnishings of the Home will illustrate the developing career of Abraham Lincoln in Springfield (Objective 1), the life of the Lincoln family in the Home (Objective 2), and the manner in which Lincoln's environment reflected and influenced his social and political life (Objectives 3 & 4). Therefore, it is important that the interpretive role of the furnishings be taken into consideration throughout this document.

The Home will be furnished to its appearance in 1860 as fully and accurately as available furnishings and documentation permit.

## SECTION B: OPERATING PLAN

The Lincoln Home is open year round for public visitation from 8:00 a.m. to 5:00 p.m., with extended hours provided in the summer. There are a minimum of two interpreters stationed in the Home during the hours that it is open to the public, with one interpreter stationed on the first floor and the other on the second floor. These staff members provide security for the artifacts and building, as well as interpreting the Home to the visitors. A Museum Aid cleans the Home and artifacts, thereby increasing the longevity of these historical materials. Lexan barriers topped with a wooden railing restrict visitor movement throughout the Home and permit limited visitor access to the rooms.

Photoelectric alarm units activate an alarm bell should visitors reach or step over the railings. Ultrasonic detectors are also operational during hours that the Home is closed and are connected to the Springfield Police Department. Ionization (smoke) detectors and fixed temperature (heat) detectors activate a fire detection system that is connected to the Springfield Fire Department on a twenty-four hour a day basis.

Visitors to the Lincoln Home will enter the structure through the front door on the west side of the building. The interpreter on

the first floor will then direct the visitors from the front hallway of the Home into the formal parlor. The visitors will move along the south side of the formal parlor and rear parlor into the dining room. Visitors will then proceed along the west side of the dining room and move through a doorway into the sitting room. After viewing the sitting room from the north side of the room, visitors will move back into the front hallway.

Visitors will then ascend the stairs to the upper hallway, from which they can view the front guest bedroom through the door of the room. From the upper hallway, they will move into Lincoln's bedroom. Visitors will then progress through Mrs. Lincoln's room. From there, they will proceed into the second floor rear hallway.

While proceeding through the upper rear hallway, visitors have the opportunity to look into the Boys' room and the sewing or maid's room. Viewing would be from the doorways of these rooms. They then descend the rear stairway on the east side of the building and view the kitchen from the south side of the room. After viewing the kitchen, visitors will exit from the rear door of the Home, near the southeast corner of the structure, where they may view the storage room on the back porch.

The Trunk Room will not be furnished but will continue to serve staff and site management needs.

## HISTORICAL DATA

### SECTION C: ANALYSIS OF HISTORICAL OCCUPANCY

The Lincoln house on 8th and Jackson Streets in Springfield was the only one Abraham Lincoln ever owned. Following their marriage on November 4, 1842, the Lincolns began housekeeping in rooms at the Globe Tavern. Other young couples in Springfield also had begun married life at the Globe, including two of Mary Todd's relatives, the John Todd Stuarts and the William Wallaces. In fact, the Lincolns moved into the same rooms which the Wallaces had occupied for three years.<sup>1</sup>

The Lincoln's first child, Robert Todd, was born at the Globe, August 1, 1843. Soon after the birth of their child the Lincolns moved. They spent the winter of 1843-1844 in a rented three-room cottage at 214 South Fourth Street while they looked for a house to buy. In January 1844, Lincoln began the transactions to buy the Reverend Henry Dresser's (the same Reverend Dresser who had performed the Lincoln's marriage ceremony) 8th Street home. In May of that year, the Lincolns completed negotiations, paying Dresser a total of \$1,200 for the 8th Street house and one downtown lot and building valued at \$300.

Between 1842 and 1861, Lincoln rose in stature from a local lawyer to a national political figure. During this period, his

income also increased significantly. At the time the Lincolns purchased the 8th Street house, Lincoln's income from his law practice has been estimated as better than average for a Springfield resident. According to Harry E. Pratt, in his work on the personal finances of Lincoln between 1840 and 1850, Lincoln earned about \$1,500 to \$2,000 a year.<sup>2</sup> His income increased during the 1850s and in at least one year he earned more than \$5,000.<sup>3</sup> A more recent study of Lincoln's legal career, by John Paul Frank, maintains that Lincoln may have earned even more during this time. Frank bases this belief on the large number of cases Lincoln handled--many of which he believes should have earned Lincoln substantial fees.<sup>4</sup> By the 1850s, Lincoln was earning enough money from his law practice to supplement his income by loaning out small- to medium-sized sums to his friends and neighbors at 10 percent interest.<sup>5</sup>

Nonetheless when Lincoln purchased the 8th Street house, it must have represented a substantial initial investment for the recently married couple. The house was then a small story-and-a-half cottage. In 1856, the Lincolns decided to enlarge it. There are several possible explanations for the Lincolns' decision to make changes in their house at this time. They had three growing boys whose well-known mischievousness probably made the house seem small indeed.<sup>6</sup> Bob was 12, Willie, 5 (born December 21, 1850),



and Tad, 3 (born April 4, 1853) at the time of the enlargement. Their other son Edward, born February 1, 1846, died ten months before Willie was born on December 21, 1850. The larger house also would help to increase Lincoln's social standing in the community and allow Mary to entertain their friends on a grander scale.<sup>7</sup>

The Lincolns made improvements on their house, although exactly what was done at this time is somewhat conjectural. The house was enlarged; four bedrooms at the rear of the house may have been added; and alterations may have been made to the two rooms on the north side of the first floor to create a double parlor, which could be separated into front and back parlors by closing folding doors.<sup>8</sup>

Before the renovations, the use of the second floor was probably reserved for bedrooms for the Lincoln family, with Mary and Abraham in one room and the boys in the other. One anecdote told in 1903 by Gibson Harris, Lincoln's law clerk during the years 1845 to 1847, suggests this arrangement:

Mr. Lincoln sometimes told at the office the sayings or doings of his children. One such account I remember as well as if I had heard it last week. He came in, an hour or so after dinner, smiling beyond even his wont and said he was lying down at home, having left his boots in the second-story hallway, when all at once he heard a tremendous clatter on the stairs. He jumped up, hurried to the head

of the stairs, and looking down, saw Bob (Robert Todd Lincoln, aged three) getting up on all fours from the floor of the hallway below, unhurt but sadly bewildered. "The youngster had got into my boots," he said, "and in trying to walk around in them had fallen down-stairs. You ought to have seen him, Gibson -- he looked so comical with the bootlegs reaching clear up to his little body."<sup>9</sup>

On at least two occasions before 1856 relatives of the Lincolns made lengthy visits. Harriet Chapman, a cousin of Mr. Lincoln, was one of those who stayed for an extended visit; she arrived soon after they had moved into the 8th Street house and remained a year and a half.<sup>10</sup>

Another visitor to the Lincoln household was Emilie Todd, Mary's younger half-sister. Emilie spent six months with the Lincolns in 1854-1855 to get a taste of Springfield society.<sup>11</sup>

There is no evidence as to where Harriet Chapman or Emilie Todd stayed while visiting the Lincolns. After the 1856 addition, the room most likely given to guests was the second floor south front bedroom. Oral tradition supports this usage<sup>12</sup> and it seems reasonable to suppose that Mary Lincoln would have put her visitors in the best possible room. In 1859, a Miss Cochran visited the Lincoln home. On October 2 of that year, Mrs. Lincoln reported to her friend, Hannah Shearer, that "I have invited Miss Cochran and she is spending some weeks with me...."<sup>13</sup>

Mary, as Harriet Chapman described her, liked "to put on style."<sup>14</sup> Moreover it was a common Victorian practice to close off those rooms reserved for company--frequently the nicest in the house. Mrs. John T. Stuart reinforced this view with the comment that at the time the Lincolns enlarged their house, Mary Lincoln seldom used what she had solely for the family.<sup>15</sup>

There are no period sources that illuminate the use of the rooms on the second floor. Oral tradition places Mr. Lincoln in the north front bedroom, Mrs. Lincoln next to him on the north side with the two younger boys, Robert across the hall from Mrs. Lincoln, and the maid at the end of the hall on the north, which leaves one room at the end of the hall on the south side, now designated as the trunk room.<sup>16</sup> The first written references to the use of the second floor occur in A.L. Bowen's "A. Lincoln: His House," Lincoln Centennial Association Papers (Springfield, Illinois, 1925). According to Bowen, the boys slept in Mrs. Lincoln's bedroom.<sup>17</sup>

Early in 1857, Mr. Lincoln traded in a trundle bed for a "cottage bedstead."<sup>18</sup> A trundle bed is one which pulls out from beneath a larger bed. The presence of a trundle bed indicates that several people in the Lincoln household were sleeping in the same room, most logically the children. There was evidently room for a

regular bed in place of a trundle bed, thereby indicating that the children were being given additional space.

There is evidence that the youngest child may have slept in his father's bed while the Lincoln family lived in the White House. According to John Hay, Lincoln's secretary at the White House, Tad always slept with his father.<sup>19</sup> This practice may have been continued from his earlier childhood in Springfield.

The earliest known set of architectural drawings of the Lincoln Home that designates room usage was made about 1888 when the house was given to the State.<sup>20</sup> On these plans, the second floor rooms are labeled as bedrooms, with those rooms facing 8th Street designated as "Front bedrooms" and the remaining rooms as "Rear bedrooms." The first written identification of the south rear bedroom as the trunk room dates to A.L. Bowen's article in 1925.<sup>21</sup> The first floor rooms, however, are labeled more clearly as living room, front parlor, back parlor, dining room, kitchen, south porch, pantry, and old porch.

Contemporary written and pictorial accounts of the Lincoln Home at the time of the Republican Convention Committee's visit to inform Lincoln of his nomination, confirms the usage of the first floor rooms suggested by the 1888 plans. One article describes the home as:

A large two-story wooden house, raised considerable above the level of the street, and dwarfing by its greater height and size, the adjoining buildings....The door opens into a broad hall, with rooms upon either side. Mr. Lincoln, who had been apprized of our coming, stood at the back end of the double parlor on the left, in<sup>22</sup> which was a bookcase filled with law books.

An article in the New York Evening Post said:

I found Mr. Lincoln living in a handsome, but not pretentious, double-two story house, having a wide hall running throughout the centre, with parlors on both sides,<sup>23</sup> neatly but not ostentatiously furnished....

Two other accounts state that the Committee gathered in the "large north parlor" where Lincoln stood in the east end of the room and after the Committee's presentation they then moved to the "south parlor" or the sitting room where Mrs. Lincoln had set up refreshments.<sup>24</sup>

In February 1867, a newspaper article was written by the Reverend Edwin S. Walker who had visited the Lincoln Home in the fall of 1866. His description included mention of the dining room and kitchen as used by the tenants of the home:

Through the center of the house, east and west, is a hall, on the left of which are two parlors connected by folding doors.... On the south side of the hall is a sitting room fronting westward and southward; in the rear of this also fronting southward is the dining room, and still further east are the kitchen<sup>25</sup> and other rooms occupying the east wing.

"Other rooms occupying the east wing" probably refers to the back porch and pantry.

On March 9, 1861, Frank Leslie's Illustrated Magazine contained sketches of three of the first floor rooms, the front and back parlors and sitting room, which clearly show that the parlors were the Lincolns' more formal reception rooms and the sitting room was the family living area.<sup>26</sup>

The family living area had to accommodate a family with three very active boys. The Lincolns were indulgent parents and many tales of the boys' pranks have survived. Mrs. Lincoln is reported to have once said about disciplining her children, "They never required it, a gentle loving word was all sufficient with them."<sup>27</sup>

And, in one of the few existing personal letters written by Mr. Lincoln, he wrote of Bob who was off to college:

Our eldest boy, Bob, had been away from us nearly a year at school, and will enter Harvard University this month. He promises very well, considering we never controlled him much.

It seems likely that Lincoln, who was frequently away from home, probably did overindulge his children when he was with them. In later years, Robert commented:

My father's life was of a kind which gave me but little opportunity to learn the details of his early career. During my childhood and early youth, he was almost constantly away from home, attending courts or making political speeches.<sup>29</sup>

Family and neighbors' recollections show that Lincoln enjoyed his children and evidently spent as much time as he could with them.<sup>30</sup>

Family evenings at home included blind man's bluff,<sup>31</sup> chess, checkers,<sup>32</sup> and reading.<sup>33</sup> Lincoln spent much of his spare time reading and often read aloud.<sup>34</sup> Harriet Chapman also remembered Lincoln lying on the floor, leaning his back against an upturned chair, and reciting poetry.<sup>35</sup> Mary, too, was an avid reader and occasionally reviewed works for Lincoln.<sup>36</sup>

At the time of Emilie Todd's visit, Mary was reading the novels of Sir Walter Scott to her son Bob. Emilie recounted an amusing occasion on which Bob enacted a Scott drama:

...one day hearing sounds of strife, we ran to the window. Bob and a playmate were having a royal battle. Bob, with his sturdy little legs wide apart, was wielding a fence paling in lieu of a lance and proclaiming in a loud voice, 'this rock shall fly from its firm base as soon as I.' Mary, bubbling with laughter, called out, 'Grammercy, brave Knights,<sup>37</sup> Pray be more merciful than you are brawny.'

Mary also spent time sewing. She was an accomplished seamstress and sewed for herself and the boys.<sup>38</sup> In one of her letters to Lincoln in Washington, she refers to the quantity of sewing required by the children. She wrote to him explaining why she desired to have a box of children's clothes sent to her, "...it takes so many changes to do children, particularly in summer, that I thought it might save me a few stitches."<sup>39</sup> During the Lincolns' last years in Springfield, however, Mary used a seamstress.<sup>40</sup>

In addition to the lively family, there is some evidence that the 8th Street house sheltered at least one pet. A few years after their removal to Washington, Lincoln's friend and barber, William Florville, remarked in a letter, "Tell Taddy that his (and Willys) dog is alive and kicking doing well...."<sup>41</sup> During their years in Springfield, the Lincolns probably had other pets as well. Lincoln was known to be fond of cats,<sup>42</sup> and Herndon once commented that the Lincoln house was overrun with pets.<sup>43</sup>

After the Lincolns moved into the house on 8th Street, they probably had hired help of some sort. With Lincoln away as much as he was, it seems unlikely he would have left Mary alone with the household chores and the baby. Mary also regularly suffered from bad headaches and help with the children would have been necessary at those times.<sup>44</sup> Harriet Hanks Chapman may have



helped during the eighteen months she spent with the Lincolns; but, probably after the birth of the Lincolns' second child in 1846, they had a regular servant. Correspondence between the Lincolns, while he was sitting in Congress and she was visiting her family, show the concern he had both with her health and that she have help with the children.<sup>45</sup> He urged her to hire someone while she was in Kentucky. If he was concerned about her in Lexington where her family had household servants, it seems unlikely that she would have been left without help in Springfield during those early years.

In the 1850 Springfield Census, a hired girl, Catherine Gordon (age 18, born in Ireland), is listed as a member of the Lincoln household.<sup>46</sup> The 1855 census also lists one unidentified female between the ages of 10 and 20 as living in the Lincoln household.<sup>47</sup> Catherine was evidently one of a succession of Irish girls; for, Mary wrote to her sister in 1856 commenting on Irish servants:

If some of you Kentuckians, had to deal with the "Wild Irish," as we housekeepers are sometimes called upon to do, the South would certainly elect Mr. Fillmore next time.<sup>48</sup>

Herndon, in his biography of Lincoln, commented that Mary had difficulty keeping servants because of her "peculiar nature;"<sup>49</sup> however, most families had difficulties keeping hired help for

any length of time. Population studies have shown that nineteenth century domestic workers in America were very transient.

There is evidence that Mary had at least one servant for several years. In a letter, written to Hannah Shearer on October 2, 1859, she remarked that "Mary, the same girl I had last winter, is still with me, a very faithful servant, has become as submissive as possible."<sup>50</sup>

"Mary" also may be the same "M. Johnson," a hired girl listed as residing in the Lincoln household in the 1860 Census.<sup>51</sup> In addition to M. Johnson, the 1860 Census listed a fourteen-year-old boy, Phillip Dinkell, as a member of the household. One neighborhood boy reminisced that Mr. Lincoln used to pay him five cents a night to stay in the house while he was away.<sup>52</sup> Staying overnight at the Lincolns' may have been one of Phillip's major duties. A Mrs. Dinkell, according to the Springfield City Directory, lived not far from the Lincolns and she may have been Phillip's mother. It seems likely, however, that Phillip also performed other chores. With Lincoln's political campaigning and the additional entertaining the Lincolns were doing in the years after they enlarged their house, they probably needed additional help. Up to that time, however, it seems they had only one servant. Emilie Todd recalled that just one girl helped Mary

during her visit in 1854-1855.<sup>53</sup> Certainly while campaigning, Lincoln had little time for the chores he used to do when they first moved into the house.

Gustave Koerner remembered that at the time of the visit to the Lincoln home by the Republican nominating committee, a black man was helping Mrs. Lincoln set up refreshments and he referred to Lincoln as "Master."<sup>54</sup> He does not appear in any record, and it seems most probable that he was temporary help for the special occasion.

When the Lincolns moved to the White House, they took two servants with them from Springfield. Mary Lincoln wrote to her friend Mary Brayman in June 1861, commenting:

In New York, I procured an excellent dressing maid and seamstress, the girl Ellen, whom I brought from S -- is not expert with her needle, or does not understand arranging or dressing a lady. Yet she is the most reliable, truthful, kindhearted girl about children, I have ever known....She is so kind I dislike to part with her, now as my boys, have grown too large, to require a nurse. We brought a man with<sup>55</sup> us, who takes care of them, most of the time.

The Lincolns easily entered into Springfield social life. Mary had mingled in the best society in her home town, Lexington, Kentucky, and when she went to live with her well-to-do sister, Mrs. Ninian Edwards in 1839, she was launched into Springfield

Society. She became known as one of the town "belles." Lincoln was also a popular young man, well-known for his wit and entertaining stories. Mary, like her sister, attended the Presbyterian Church and probably attended some of the Presbyterian Church suppers, where Mrs. Edwards was famed for her chicken salad.<sup>56</sup> After the Lincolns' marriage, they annually rented a pew. Although Mr. Lincoln was not a church member, he often accompanied Mary.

Isaac Arnold, a friend of the Lincolns and a frequent visitor to Springfield, recalled "the dinners and evening parties given by Mrs. Lincoln."<sup>57</sup> He recounted:

In her modest and simple home, everything orderly and refined, there was always, on the part of both host and hostess, a cordial and hearty Western welcome, which put every guest perfectly at ease. Mrs. Lincoln's table was famed for the excellence of many rare Kentucky dishes, and in season, it was loaded with venison, wild turkey, prairie chickens, quail and other game, which was abundant. Yet it was her genial manners and ever kind welcome, and Mr. Lincoln's wit and humour, anecdotes and unrivalled conversation, which formed the chief attraction.<sup>58</sup>

On several occasions when Lincoln was unable to accompany his wife to social functions, his law clerk Gibson Harris, escorted her. Harris' recollections include a vivid description of Mary's personality:

As a frequent visitor I was made welcome at the Lincoln home, and on two different occasions, at the insistence of Mr. Lincoln, he being unable to attend, I became Mrs. Lincoln's escort to a ball where I danced with her. I always found her most pleasant-mannered. She was a bright, witty and accomplished young woman, naturally fond of fun and frolic, but very staid and proper when it was in order to be so. I was impressed with her brilliant conversational powers, and <sup>59</sup> the superior education she constantly evinced.

A letter written in November 1860 from the daughter of one of the Lincoln's friends, Ada Bailhache, to her mother, described both Lincolns:

I spent an evening at Mr. Lincoln's a few evenings since and had a very pleasant time. Mr. L. has not altered one bit -- he amused us nearly all the evening telling funny stories and cracking jokes....Mrs. L. is just as agreeable as ever, does not put on any airs at all but is pleasant and <sup>60</sup> talkative and entertaining as she can be....

Mrs. Lincoln's own correspondence provides several references to other evening parties. The following invitation to the wife of another Springfield lawyer was for an impromptu gathering at the Lincolns'. Mary wrote to Mary Brayman on a Saturday afternoon in 1857, "...we would be much pleased to have you, Mr. B -- and the young ladies come round, this eve about seven and pass a social evening also any friend you may have with you."<sup>61</sup> Another example of a small party at the Lincoln home may be found in Mrs. Lin-

coln's correspondence to Hannah Shearer in April 1859; she wrote, "Mr. Dubois' family and Mr. Hatch took tea with us a few evenings since...."<sup>62</sup>

The Lincolns were particularly busy during Christmas, New Years, the first part of the year when the state legislature met, and in June during berry season. They were hosted by their friends and neighbors and periodically gave large entertainments themselves. The earliest evidence of large parties at the Lincoln home is a check written by Lincoln to W.W. Watson, confectioners, in December 1855.<sup>63</sup> Watson was famous for his macaroon pyramids, according to Caroline Owsley Brown, a pre-Civil War Springfield resident. She wrote:

Mr. Watson, the confectioner, way back in the forties, had gone to St. Louis to learn to make the famous macaroon pyramids, without which no party table was complete, each New Year's table bore one of these sticky monuments as its central adornment.<sup>64</sup>

Watson also advertised such items as, "Fresh Baltimore Oysters in cans, Hamburgh Cheese, W.R. Cheese, Pine Apple Cheese, Sardines, Zante Currants, Citron, Almonds, English Walnuts, Cranberries, Crackers, Assorted 100 Boxes Candies, Cove Oysters, Sultana Raisins, Belden's Sugars, Brazil Nuts, and Fireworks."<sup>65</sup>

Mr. Lincoln's check to Watson probably covered accumulated charges, including the famed macaroon pyramids. One recorded

instance of Mrs. Lincoln's use of these confections is a recollection that after a party in 1861 she gave one to a neighbor who had just had a baby.<sup>66</sup>

On New Year's Day it was customary in Springfield for the residents to hold open house. On New Year's, in 1860, Mrs. Lincoln commented to her friend Hannah Shearer, "...tomorrow I must rise early, as it is receiving day...."<sup>67</sup> A vivid description of this custom and the need for arising early may be found in Mrs. Brown's account:

As a child, I can remember the great hurry and flurry that stirred the household on this festive occasion, to get the parlors to a comfortable degree of temperature, for some early birds came about 9 o'clock, and they were generally quite old birds that should have known better....

In this icy atmosphere egg-nogg was very tempting, and many a young gallant found it hard to stand upright about six P.M. At each house the caller was expected to eat oysters, chicken-salad, drink coffee, put down a saucer of ice-cream and cake, and nibble a few bonbons. Where the oranges came in I do not know, but this I can confirm, that with skins cut in fancy shapes, they were always present on the table, as well as raisins, almonds, and white grapes. The first oranges of the season came at Christmas and the <sup>New</sup> Year, and very seldom at any other time....<sup>68</sup>

In February of 1857 and 1859, at which time the legislature was meeting, the Lincolns gave large parties. Ruth Painter Randall, in her biography of Mary Lincoln, described these parties as

"political entertaining" by the Lincolns.<sup>69</sup> Mary Lincoln wrote to her sister Emilie Helm about the party she and Mr. Lincoln gave on February 5, 1857:

Within the last three weeks, there has been a party, almost every night and some two or three grand fetes, are coming off this week -- I may perhaps surprize you, when I mention that I am recovering from the slight fatigue of a very large and I really believe a very handsome and agreeable entertainment, at least our friends flatter us by saying so -- About 500 were invited yet owing to an unlucky rain, 300 only favored us by their presence....<sup>70</sup>

For such large entertainments, Caroline Owsley recounted that it was customary to dismantle the beds to allow for more room.<sup>71</sup>

Lincoln, himself, took part in the preparations for this party; several of the extant invitations are in his hand. They read, "Mr. and Mrs. Lincoln will be pleased to see you Thursday evening February 5 at 8 o'clock."<sup>72</sup> Henry G. Little, one of the legislators who attended the party in February 1857, later remembered the food arrangement and a comment made to him by Mr. Lincoln:

A long table was stretched nearly the whole length of the room, while above the table was a succession of shelves growing narrower upward. On these shelves the edibles were placed, and the guests...were left to help themselves, the waiters serving only coffee.<sup>73</sup>

Lincoln joined Little before the table and asked jokingly, "Do they give you anything to eat here?"<sup>74</sup>



A different kind of party was given in June, during berry season. Mrs. Lincoln wrote to her friend Hannah Shearer in 1859 describing her recent activities:

For the last two weeks, we have had a continual round of strawberry parties, this last week I have spent five evenings out.... This last week, we gave a strawberry company of about seventy.... After raspberry time,<sup>75</sup> we will resume, doubtless our usual quiet....

John T. Stuart wrote to his daughter (June 2, 1856) describing one of these strawberry parties:

I was invited to Cousin Ann's today after Church to eat strawberries and ice cream. We had a fine dinner and plenty of cream and berries. Lincoln and Cousin Mary,<sup>76</sup> Mother and Myself and Dr. Wallace were there.

The Springfield children occasionally had their own festivities to attend. In January 1856, the governor held a party at his new residence for the Springfield young people on the evening following a party he gave for their parents. John Stuart described the celebration (January 13, 1856) to his daughter:

The next evening all the small "folks" were invited.... The house was full of boys and girls. The gas was in full operation -- the band was in attendance -- all the rooms were thrown open, and all the children danced or at least hopped around. John [Stuart, Jr.] danced all evening in his way. Next day he and Bob,<sup>77</sup> Lincoln were hunting up the dancing master.

Robert joined the Springfield Cadets, an organization of Springfield youth.<sup>78</sup> They practiced military drill, marched in parades, and attended evening parties given in their honor. On July 3, 1858, the Cadets placed a notice in the Illinois State Journal thanking one of their hosts:

The Springfield Cadets return their sincere thanks to Gen. John Cook for the elegant entertainment and other courtesies received at his residence...on Thursday evening....

Robert's younger brother, Willie, had a grand celebration, a combination birthday and going-away party, given December 21, 1860. "Willie's birthday came off on the 21st of December," Mrs. Lincoln wrote Hannah Shearer, "and as I had long promised him a celebration, it duly came off. Some 50 or 60 boys and girls attended the gala...."<sup>80</sup>

The Lincolns, themselves, held a final, grand going-away party, February 6, 1861, before moving into the Chenery House Hotel where they made their final arrangements for moving to Washington. A correspondent of the St. Louis Missouri Democrat who attended the Lincolns' "levee," as it was called, reported:

It was a great outpouring of citizens and strangers, together with the members of the Legislature. Your humble servant was invited to attend. Mr. Lincoln threw open his house for a general reception of all the people who felt disposed to give him and his lady a parting call. The levee lasted from seven to

twelve o'clock in the evening, and the house thronged by thousands up to a late hour. Mr. Lincoln received the guests as they entered and were made known. They then passed on, and were introduced to Mrs. Lincoln, who stood near the center of the parlors, and who, I must say, acquitted herself most gracefully and admirably. She was dressed plainly, but richly. She wore a beautiful, full train white moire antique silk, with a small French lace collar. Her neck was ornamented with a string of pearls. Her head dress was a simple and delicate vine arranged with much taste.

She displayed but little jewelry, and this was well and appropriately adjusted. She is a lady of fine figure and accomplished address, and is well calculated to grace and do honors at the White House.<sup>81</sup>

From these accounts of the daily life and entertaining of the Lincolns, it is apparent that they changed the small house on 8th Street into an acceptable house for substantial gatherings and for raising their active family. The evidence about the family's size, economic status, and social schedule also indicate that the house was a very lively, and quite lived-in structure while the Lincolns called it home.

FOOTNOTES TO SECTION C

1. James T. Hickey, "The Lincolns Globe Tavern, A Study in Tracing the History of a Nineteenth Century Building," The Journal of the Illinois State Historical Society, LVI, no. 4, Winter, 1963, p. 638.

2. Harry E. Pratt, The Personal Finances of Abraham Lincoln (Springfield, Illinois: The Abraham Lincoln Association 1943), p. 84.

3. Ibid., p. viii.

4. John Paul Frank, Lincoln As A Lawyer (Urbana:University of Illinois Press, 1961), p. 40.

5. Pratt, Finances, p. 82.

6. See Ruth Painter Randall, Lincoln's Sons (Boston and Toronto: Little, Brown & Co., 1955).

7. See William E. Baringer, Lincoln Day By Day: A Chronology 1809-1865 (Washington: Lincoln Sesquicentennial Commission, 1960) for a record of the Lincolns' parties. Two examples of large parties given after 1856 may be found on pp. 189 and 242.

8. Edwin C. Bearss, Historic Structure Report, Lincoln Home National Historic Site, Illinois (Denver Service Center, National Park Service, July, 1973), pp. 17-18, 94.

9. Gibson William Harris, "My Recollections of Abraham Lincoln," Woman's Home Companion, November, 1903, p. 11.

10. According to James Hickey, Curator of the Lincoln Collection, Illinois State Historical Library, Harriet Chapman came to the Lincoln home to work as a hired girl.

11. Katherine Helm, Mary, Wife of Lincoln (New York and London: Harper and Brothers, 1928), pp. 106-112.

12. Bearss, Historic Structure Report, p. 108, and A.L. Bowen, "A. Lincoln: His House" in Lincoln Centennial Association Papers (Springfield, Illinois: Lincoln Centennial Association, 1925), pp. 44-45.

13. Mary Lincoln to Hannah Shearer, October 2, 1854, quoted in Justin G. Turner and Linda Levitt Turner, Mary Todd Lincoln: Her Life and Letters (New York: Alfred A. Knopf, 1972), p. 59.

14. Chapman to Herndon, December 10, 1866, Herndon-Weik Collection.

15. Mrs. John T. Stuart to Elizabeth Stuart, April 3, 1856 quoted in Bearss, Historic Structure Report, p. 17.

16. Bearss, Historic Structure Report, p. 108.

17. A.L. Bowen, "A. Lincoln: His House." Lincoln Centennial Association Papers (Springfield, Illinois: Privately Printed, 1925), p. 44.

18. Pratt, Finances, p. 92.

19. John Hay to William Herndon, September 5, 1866, quoted in The Hidden Lincoln, p. 307.

20. Copy of Lincoln Home drawings obtained from Ferry and Henderson, Architects, Inc., 1320 South State Street, Springfield, Illinois, 62704.

21. Bowen, "A. Lincoln," p. 45.

22. New York Commercial Advertiser, May 25; the New York Evening Post, May 26; and the New York Sun, May 30, June 9, 1860 quoted in Bearss, Historic Structure Report, p. 23.

23. New York Evening Post, May 23, 1860 quoted in Kenneth Scott, "Lincoln's Home in 1860," The Journal of the Illinois State Historical Society, 46, no. 1, (1953), pp. 7-8.

24. New York Daily Tribune, May 25, 1860, quoted in Bearss, Historic Structure Report, p. 24; and Gustave Koerner, Memoirs of Gustave Koerner, 1809-1896 (Cedar Rapids: The Torch Press, 1909), Vol. II, pp. 93-95.

25. Edwin S. Walker quoted in Scott, "Lincoln's Home in 1860," p. 12.

26. Frank Leslie's Illustrated Newspaper, March 9, 1861.

27. Ruth Painter Randall, I, Mary (Boston and Toronto: Little, Brown and Company, 1959), p. 111.

28. Abraham Lincoln to Dr. A. G. Henry, July 4, 1860 quoted in Paul Angle, ed., The Lincoln Reader (New Brunswick, New Jersey: Rutgers University Press, 1947), pp. 283-284.

29. Randall, Lincoln's Sons, p. 51.

30. See Ruth Painter Randall's Lincoln's Sons.

31. Randall, Mary Lincoln, p. 92.

32. Katherine Helm, Mary, Wife of Lincoln (New York and London: Harper and Brothers, 1928), p. 110.

33. Harriet Chapman to William Herndon, November 21, 1866, Herndon-Weik Collection.

34. William H. Herndon and Jesse W. Weik, Abraham Lincoln: The True Story of a Great Life, Vol. II (New York: D. Appleton and Company, 1896), p. 1; and Chapman to Herndon, November 21, 1866, Herndon-Weik Collection.

35. Chapman to Herndon, November 21, 1866, Herndon-Weik Collection.

36. Katherine Helm, Mary, p. 108.

37. Ibid., p. 108.

38. Emilie Todd Helm, "Mary Todd Lincoln: Reminiscences and Letters of the Wife of President Lincoln," McClure's Magazine, September 1898, p. 479.

39. Mary Lincoln to Abraham Lincoln, May 1848 quoted in Paul Angle, ed., The Lincoln Reader, pp. 147-148.

40. See reference to seamstresses in Mary Lincoln to Hannah Shearer, April 24, 1859 (incomplete) quoted in Turner, Mary Todd Lincoln, p. 55.

41. Randall, Mary Lincoln, p. 155.

42. Ibid., p. 149.

43. Randall, Lincoln's Sons, p. 44.

44. Carl Sandburg and Paul M. Angle, Mary Lincoln, Wife and Widow (New York: Harcourt, Brace, 1939), p. 67; and Abraham Lincoln to Mary Lincoln, April 16, 1848, quoted in Paul Angle, ed., The Lincoln Reader, pp. 146-147. Lincoln wrote: "And you are entirely free from headache? That is good--considering it is the first spring you have been free from it since we were acquainted...."

45. Abraham Lincoln to Mary Lincoln, July 2, 1848, quoted in Angle, Lincoln Reader, pp. 150-151.

46. Population Schedules of the Seventh Census of the United States, 1850, Illinois, Saline and Sangamon Counties, National Archives and Records Service, Washington, D. C.

47. Wayne C. Temple, "Lincoln in the Census," Lincoln Herald, vol. 68, no. 3 (1966), p. 138.

48. Mary Lincoln to Emilie Todd Helm, November 23, 1856 quoted in Turner, Mary Todd Lincoln, p. 46.

49. Herndon, Abraham Lincoln, vol. II, p. 137.

50. Mary Lincoln to Hannah Shearer, October 2, 1859, quoted in Turner, Mary Todd Lincoln, p. 59.

51. Population Schedules of the Eighth Census of the United States, 1860, Illinois, Sangamon County, NARS.

52. Randall, Mary Lincoln, p. 61.

53. Katherine Helm, Mary; recollections of Emilie Todd, p. 112.

54. Gustave Koerner, Memoirs, II, pp. 93-94.

55. Mary Lincoln to Mary Brayman, June 17, 1861, quoted in Turner, Mary Todd Lincoln, p. 90.

56. Caroline Owsley Brown, "Springfield Society Before the Civil War," Journal of the Illinois State Historical Society, vol. 15, nos. 1-2, p. 479.



57. Isaac Arnold's Addresses to the Illinois State Bar Association (1881) quoted in Pratt, Finances, p. 94.
58. Ibid., p. 94.
59. Harris, "Recollections of Lincoln," p. 11.
60. Ada Bailhache to Mrs. William Bailhache, November 20, 1860, quoted in Pratt, "Concerning Mr. Lincoln," p. 32.
61. Mary Lincoln to Mary Brayman, "Saturday afternoon," 1857, quoted in Turner, Mary Todd Lincoln, p. 51.
62. Mary Lincoln to Hannah Shearer, April 24, 1859, quoted in Turner, Mary Todd Lincoln, p. 55.
63. Pratt, Finances, p. 92.
64. Brown, "Springfield Society," pp. 494-495.
65. Daily Illinois State Journal, January 7, 1857, W. W. Watson advertisement, p. 4.
66. Randall, Mary Lincoln, p. 153.
67. Mary Lincoln to Hannah Shearer, January 1, 1860, quoted in Turner, Mary Todd Lincoln, p. 61.
68. Brown, "Springfield Society," p. 494.
69. Randall, Mary Lincoln, p. 176.

70. Mary Lincoln to Emilie Helm, February 16, 1857,  
quoted in Turner, Mary Todd Lincoln, p. 48.

71. Brown, "Springfield Society," p. 483.

72. Basler, Collected Works, p. 388.

73. Henry G. Little, quoted in Randall, Lincoln's Sons,  
p. 60.

74. *Ibid.*, p. 60.

75. Mary Lincoln to Hannah Shearer, June 26, 1854,  
quoted in Turner, Mary Todd Lincoln, p. 55.

76. John T. Stuart to his daughter, June 2, 1856,  
quoted in Pratt, Finances, p. 97.

77. John T. Stuart to his daughter, January 13, 1856,  
quoted *Ibid.*, p. 97.

78. Randall, Lincoln's Sons, p. 59.

79. Illinois State Journal, July 3, 1858, quoted in  
Randall, Lincoln's Sons, p. 59.

80. Mary Lincoln to Hannah Shearer, January 1, 1860,  
quoted in Turner, Mary Todd Lincoln, p. 61.

81. St. Louis Missouri Democrat, February, 1861, quoted  
in Pratt, Personal Finances, p. 98.

## SECTION D: EVIDENCE OF ORIGINAL FURNISHINGS

### INTRODUCTION

The evidence of original Lincoln Home furnishings includes a wide variety of sources: drawings and photographs, contemporary accounts, evidence of the 1861 sale of Lincoln furniture, Springfield account books which list Lincoln family purchases, existing furniture, and records of furniture which is now missing. As new documentation is found, it should be added to this report. One area which needs further research is past exhibitions (such as state centennial exhibitions) of Lincolniana.

This material has been organized by location within the house (first floor, kitchen, and second floor furnishings) with separate sections on accessory furnishings, floor coverings, textiles, and wallpaper. The first floor furnishings are also divided into well-documented items and not well-documented items and are listed alphabetically by type of artifact. The contemporary accounts and pictorial evidence are discussed separately and by reference in the discussions of different areas.

### CONTEMPORARY ACCOUNTS

Although some information is available for the entire historic period, many accounts describing Lincoln's home were written at the time of his nomination for the presidency. The following

pages, presented in chronological order, present those accounts that refer to the interior appointments of the house, including several written by Lincoln's contemporaries but after Lincoln's death. One of these accounts lists Lincoln furniture purchased by the Lucien Tiltens who rented the Lincoln home while Lincoln was President. These accounts focus on the first floor rooms, primarily the east and west parlors. A summary of the furniture mentioned begins on page 43:

Account by Charles Carleton Coffin, western correspondent of the Boston Journal, May 1860, quoted in Paul Angle, ed., The Lincoln Reader (New Brunswick, 1947), pp. 278-280.<sup>1</sup>

...I crossed the hall and entered the library. There were miscellaneous books on the shelves, two globes, celestial and terrestrial, in the corners of the room, a plain table with writing materials upon it, a pitcher of cold water, and glasses, but no wines or liquors....

Springfield (Mass.) Republican, May 23, 1860.<sup>2</sup>

As nearly as could be made out in the evening light [of May 19], his dwelling house is of the style and character suited to his position in life. It is a two-story wooden house of more than ordinary good exterior; and the interior arrangements are such as show that good taste and good domestic rule reigns within. The furniture, without pretension to show, was neat, and in admirable keeping with what is understood to be his moderate pecuniary ability. Everything tended to represent the home of a man who has battled hard with the fortunes of life, and whose hard experience has taught him to enjoy whatever of success belongs to him, rather in solid substance than in showy display.

New York Evening Post, May 23, 1860.<sup>3</sup>

I found Mr. Lincoln living in a handsome, but not pretentious, double two-story house, having a wide hall running through the centre, with parlors on both sides, neatly, but not ostentatiously furnished. It was just such a dwelling as a majority of the well-to-do residents of these fine western towns occupy. Everything about it had a look of comfort and independence. The library, I remarked on passing, particularly, that I was pleased to see long rows of books, which told of scholarly tastes and culture of the family.

New York Commercial Advertiser, May 25; the New York Evening Post, May 26; and New York Sun, May 30, June 9, 1860.<sup>4</sup>

The door opens into a broad hall, with rooms upon either side. Mr. Lincoln, who had been apprised of our coming, stood at the back end of the double parlor on the left,--in which was a bookcase filled with law books,--and the committee and other guests upon entering grouped themselves around him.

By editorial correspondent of The Utica Morning Herald, letter dated Springfield, Illinois, June 21, 1860, and reprinted in the New York Semi-Weekly of July 6, 1860, under the caption, "An Evening with Lincoln." Ed.<sup>5</sup>

I have an instinctive aversion to dogging the footsteps of distinguished men. Nothing was farther from my thoughts four days ago than a visit to Abraham Lincoln. Nothing seemed more impossible than that I should ever ---before or after his election to the Presidency---join the great mob of those who should 'pay him their respects'....

I had little difficulty in finding the place of my destination. A modest-looking two-story brown frame house, with the name "A. Lincoln" on the door plate, told me that

my pilgrimage was ended. I was met at the door by a servant, who ushered me into the parlor, and carried my note to Mr. Lincoln, who was upstairs. The house was neatly without being extravagantly furnished. An air of quiet refinement pervaded the place. You would have known instantly that she who presided over that modest household was a true type of American lady. There were flowers upon the table; there were pictures upon the walls. The adornments were few, but chastely appropriate; everything was in its place, and ministered to the general effect. The hand of the domestic artist was everywhere visible. The thought that involuntarily blossomed into speech was, "What a pleasant home Abe Lincoln has."

Presently, I heard footsteps on the stairs, and a tall, arrowy, angular gentleman, with a profusion of wiry hair "lying around loose" about his head, and a pair of eyes that seemed to say "make yourself at home," and a forehead remarkably broad and capacious, and arms that were somewhat too long and lank for a statue of Apollo, made his appearance. The lips were full of character, the nose strongly aquiline, the cheekbones high and prominent, and the whole face indicative at once of goodness and resoluteness. In repose, it had something of rigidity, but when in play, it was one of the most eloquent I have ever seen. None of his pictures do him the slightest justice. His presence is commanding---his manner winning to a marked degree. After you have been five minutes in his company you cease to think that he is either homely or awkward. You recognize in him a high-toned, unassuming, chivalrous-minded gentleman, fully posted in all the essential amenities of social life, and sustained by the infallible monitor of common sense.

He approached, extended his hand, and gave mine a grasp such as only a warm-hearted man knows how to give. He sat down beside me

on the sofa, and commenced talking about political affairs in my own State with a knowledge of details which surprised me....

New York Herald, June 26, 1860.<sup>6</sup>

Mr. Lincoln lives in a plain brown two-story wooden house, a little off at one side of the city, which is without ornament on it or in its grounds around it. Everything bespeaks a becoming absence of affectation and love of show, and an almost becoming absence of taste and refinement....The internal appointments of his house are plain but tasteful, and clearly show the impress of Mrs. Lincoln's hand, who is really an amiable and accomplished lady.

New York Herald, August 13, 1860.<sup>7</sup>

In a large two-story frame house, bearing no slight resemblance to Washington's headquarters at Cambridge, Massachusetts, now the residence of Professor [Henry Wadsworth] Longfellow, resides the Republican candidate for President of the United States, Abraham Lincoln. It is situated at the corner of Eighth and Jackson Streets in this city.

Here Mr. Lincoln has resided for some twenty years, since 1844. The edifice affords no indications of ostentation. It has no ornaments, no flowers or shrubbery, no marble vases or cooling fountains, no fashionable fences surrounding it, but is built plumb out to the sidewalk, the steps rather encroaching on the walk. It is like the residence of an American gentleman in easy circumstances, and is furnished in like manner. It is not near so aristocratic an establishment as the houses of many members of your Common Council. In short, there is no aristocracy about it; but it is a comfortable, cosy home, in which it would seem that a man could enjoy life, surrounded by his family.



Frank Leslie's Illustrated Newspaper, November 17, 1860.<sup>8</sup>

It [the Home] stands on a sort of platform of brickwork, and is two stories high, having two windows on each side of the door and five on the upper story. The side view shows it has an extension and side entrance with a receding stoop running the whole length of the extension. In the rear are the stables and barn. The edifice is painted a pale chocolate color, and the window blinds are of deep green. The roof extends a little over the edges, like that of a Swiss cottage. The rooms are elegantly and comfortably furnished with strong well-made furniture, made for use and not show. On the front is a black door plate, on which, in silvered Roman characters, is inscribed the magical name "A. Lincoln."

Frank Leslie's Illustrated Weekly Magazine, March 9, 1861.<sup>9</sup>

...simply and plainly fitted up, but are not without indications of taste and refinement. They are the "leisure-rooms," as parlors might properly be called, of the great majority of Americans in comfortable circumstances in country towns, and will doubtless suggest to the reader many a pleasant hour passed in such apartments....The rooms are elegantly and comfortably furnished with strong well-made furniture, made for use and not for show.

Chicago Tribune, May 6, 1865.<sup>10</sup>

There is little of the furniture in the house which belonged to Mr. Lincoln. In the front parlor is a whatnot and a small marble-topped table on which was lying a beautiful cross of white camellias. In the back parlor, which he was accustomed to use as his study, is his bookcase. This was his favorite room, and here he toiled and wrote unconsciously preparing himself for the great mission he was to fulfill....A heavy oaken bedstead and a chamber set conclude the relics.



The following article is dated February 18, 1867, but the newspaper is not identified; found in Kenneth Scott, "Lincoln's Home in 1860," Journal of the Illinois State Historical Society, Vol. XLVI, No. 1, p. 12.<sup>11</sup>

The plain, two-story brown house in which Mr. Lincoln lived, is well represented in the steel engraving found in Dr. [Joseph G.] Holland's Life of Lincoln. It is located on Eighth Street, two or three blocks southeast from the State House. Fronting westward and southward on two streets, it stands about fifteen feet from the sidewalk, its sombre aspect in full keeping with the memories which cluster around it.

A single elm tree, half a foot or so in diameter, near the edge of the sidewalk, is the only object which relieves the eye from a full view of the house. On the south, a close board fence encloses the lot two-thirds of its length, the rest of the yard, including that in front of the house, being enclosed with a plain picket fence. A climbing rose with a few other shrubs are the only natural ornaments which adorn the place.

Through the centre of the house, east and west, is a hall, on the left of which are two parlors connected by folding doors....On the south side of the hall is a sitting room fronting westward and southward; in the rear of this, also fronting southward, is the dining room, and still further east are the kitchen and other rooms occupying the east wing.

On the rear of the lot resting on the alley, is a small barn and woodshed combined, covered with boards rough from the saw, and browned by the weather. The whole establishment is embraced in a single lot, sixty by one hundred and sixty feet [152 feet] in size. It is a type of republican simplicity, which contrasts widely with the extensive mansion and numerous outbuildings, the once beautiful gar-

dens, the extended lawns, and broad fields of Mt. Vernon. The latter was a home illustrative of the tastes of the Virginia cavalier, not more so than was the plain brown house in Springfield, a home in keeping with the tastes of the Illinois lawyer.

J.S. Bliss to W.H. Herndon,<sup>12</sup> January 29, 1867, Herndon-Weik Collection, Library of Congress.

I presented myself to the door of our nominee....

I was ushered into the sitting room by the young man who answered the bell, and from that place, I sent my verbal card to Mr. Lincoln....

I was sitting opposite the door and partly in sight of the stairs. After a short time, Mr. L. came tripping down the stairs, as lively as a young man of sixteen years of age -- sliding his right hand on the bannister. He approached me and after shaking hands -- we were soon immersed in a lively conversation on various topics.

As I was from near Madison, Wisconsin, he was anxious too and did inquire as to the resources and development, to which I replied to the best of my ability.

He spoke of the press in Wisconsin, and gave readily the course they had pursued (especially some of the Milwaukee papers) as readily as a resident of that city.

While sitting there, the chimney swallows came down behind the fire boards, and absolutely twittered, fluttered, and sung as to nearly drown our voices.

I remarked that these birds rarely descend so low but Mr. L. replied "that they usually come down once a day!"

On a section of the wall of his parlor, hung a picture of himself and Mr. Herndon; since he said he had not seen Mr. Herndon yet, whereupon, I took the liberty to remark, that they would meet in the city of Washington, ere long to which he smiled in his thin, then, usual good natured style.

We stepped to the opposite side of the room where was one of the best executed pictures of Mr. Lincoln I had ever seen and it was this one, I was paying rather more than ordinary attention.

He was immediately at my left, and pointing to it, said--"that picture, gives a very fair representation of my homely face."

A whatnot in the corner of the room was laden with various kinds of shells, I took one in my hand and said:

"This, I suppose, is called a (Trowsby?) to a geologist or naturalist." Mr. Lincoln replied, "I do not know for I never studied it."

....Mr. Lincoln following without his hat -- continuing conversation, shook hands across the gate....!

Memoirs of Gustave Koerner, 1809-1896. Vol. II, pp. 93-95.<sup>13</sup>

A committee made up by the vice-president, headed by Ashmun, the president, had been appointed to inform Mr. Lincoln of his nomination. They were to start in the morning on an extra train. I went down to Springfield on the regular train, and arrived a few hours before the committee did. In company with E. Peck, later one of the judges of the Court of Claims in Washington, I called on Mr. Lincoln at his handsome, but unpretending frame house in a quiet part of the city. Entering the hall, on the right, there was a library or sitting room, which was joined at the south by

another, probably the dining room. The door of the first room was open, and there was a sort of long table set on one side, on which stood many glasses, a decanter or two of brandy, and under the table a champagne basket. Cakes and sandwiches were just being placed on the table by a colored man. We went in there first, and asked the servant what the proceeding meant. "O, this is for the Chicago folks, that come down to congratulate master." Presently, Mrs. Lincoln came in. After the customary "how do you do's?", she asked us what we thought of setting out this lunch for the committee. We told her at once that this would hardly do. This meeting of the committee would be a somewhat solemn business. Several, perhaps, of the Eastern men were strictly temperance people, and they might think treating the committee would not be the proper thing. She remonstrated in her very lively manner, but we insisted on dispensing with this hospitality, which we appreciated ourselves, but which might be misconstrued. I finally told the black man bluntly to take the things out into the back room, which he did. But, Mrs. Lincoln still argued with us. Lincoln, being in the parlor right opposite, came in, and learning of the trouble, said: "Perhaps, Mary, these gentlemen are right. After all is over, we may see about it, and some may stay and have a good time."

We went to the parlor and gave Mr. Lincoln a good many particulars about the Convention, which, of course, interested him much. Some very humorous remarks were made about it, Mr. Peck himself being a very witty and lively talker. Some other of Mr. Lincoln's particular friends called in. About six o'clock in the evening, the committee called, and after the usual salutation,---Mr. Lincoln standing on the threshold of the back parlor and leaning somewhat on an armchair,---the committee formed before him in the front parlor, and Mr. Ashmun very formally addressed him in a well-considered speech. Mr. Lincoln looked much

moved, and rather sad, evidently feeling the heavy responsibility thrown upon him. He replied briefly, but very pointedly. Somehow, all of us felt more serious than the occasion called for. All appeared to have a foreboding of the eventfulness of the moment, and all felt that in this contest there was more than the mere possession of power and office at stake, nay, the vital principle of our national existence. Ice water, it being a very hot evening, was the only refreshment served.

The Republican Committee of Springfield had arranged an elegant supper for the committee at the hotel. After that, everyone repaired to the State House and the square around it, where a vast deal of speaking and cheering was going on.

Raymond made a most capital speech in the hall of the House of Representatives,---one of the finest of the kind I ever heard. He was one of the great lights of the Republican party of New York. The whole town was alive all night. Champagne flowed in the hotels; toast followed toast. Bands of music played in the streets. Fireworks were let off. Even the Democrats, who all liked Lincoln personally, joined in the jubilee.

Abraham Lincoln by Some Men Who Knew Him, "Recollections of Judge Franklin Blades," p. 121.

On being ushered upstairs I found Mr. Lincoln and the Democratic State Auditor... sitting on a high post bed, chatting with each other, Mr. Lincoln particularly greeting all who came into the room. Mr. Lincoln was not then talked of for the presidency.

#### Summary of Furnishings Documented by Contemporary Accounts

##### Front Parlor:

Whatnot<sup>15</sup>

Small marble-topped table<sup>16</sup>

Fireboards<sup>17</sup>

A picture of himself [Lincoln] and Mr. Herndon<sup>18</sup>

A picture of Mr. Lincoln (opposite wall from picture of Lincoln and Herndon)<sup>19</sup>

A whatnot in the corner of the room<sup>20</sup>

Various kinds of shells (on whatnot)<sup>21</sup>

A Trowsby shell<sup>22</sup>

Flowers upon the table<sup>23</sup>

Pictures upon the walls<sup>24</sup>

A sofa<sup>25</sup>

#### Back Parlor:

Bookcase<sup>26</sup>

Long rows of books (in the Library)<sup>27</sup>

Arm chair (near threshold of hall and parlor)<sup>28</sup>

Two globes, celestial and terrestrial<sup>29</sup>

A plain table with writing materials upon it, a pitcher of cold water, and glasses.<sup>30</sup>

#### Sitting Room:

A sort of long table set on one side, on which stand many glasses, a decanter or two of brandy, and under the table a champagne basket.<sup>31</sup>

#### Bedroom:

Heavy oaken bedstead<sup>32</sup>

Chamber Set; and high post bed<sup>33</sup>

#### Windows:

Deep green window blinds.<sup>34</sup>

## THE LINCOLNS' 1861 SALE OF HOUSEHOLD FURNISHINGS

In February 1861, before their departure for Washington, the Lincolns sold many of their household furnishings. The following advertisement for their sale appeared January 29, 1861:

At Private Sale -- The furniture consisting of parlor and chamber sets, carpets, sofas, chairs, wardrobes, bureaus, bedsteads, stoves, china, Queensware, glass, etc., etc. at the residence, on the corner of Eighth and Jackson Streets, is offered at private sale without reserve. For<sup>35</sup>particulars apply on the premises at once.

This advertisement provides the only known contemporary listing of the contents of the Lincolns' home.

One bill of sale from the Lincoln auction is extant. It reads:

<u>S. H. Melvin</u>	<u>Bot. of A. Lincoln</u>
6 Chairs @ 2.00	12.00
1 Spring Mattress	26.00
1 Wardrobe	20.00
1 Whatnot	10.00
1 Stand	1.50
9½ Yds. Stair Carpet .50	4.75
4 Comforters @ 2.00	8.00
	<u>82.25</u> <sup>36</sup>

The fact that the Lincolns sold many of their furnishings from their Springfield home before moving to Washington adds credence to the many stories of Lincoln furnishings descending in the families of Springfield residents. Also, an examination of the White House records at the National Archives (Department of the



Treasury) has revealed little or no information on what furniture, if any, was moved from Springfield to the White House. This absence in otherwise carefully detailed lists of expenses suggests that little furniture was moved. The only references to shipping charges are for large boxes. The Lincolns did purchase many new furnishings while they were in the White House. These numerous purchases also support the supposition that few furnishings were brought from Springfield.

#### PICTORIAL EVIDENCE OF FIRST FLOOR FURNISHINGS

On March 9, 1861, three drawings of the new President's former home, the Lincoln family's parlors and sitting room, appeared in Frank Leslie's Illustrated Newspaper. See illustrations 1 thru 3. These sketches show the appearance of the rooms during the Lincolns' last winter in Springfield. Many of the details in the illustrations compare well with documented surviving Lincoln furnishings, such as the Volk Bust shown in the front parlor, or the table from the Lincoln Memorial Collection, also shown in the front parlor. The wallpaper, carpeting, and draperies, however, are not as clearly depicted; it is supposed that the patterns have been simplified.

In 1865, five stereoscope views were made of the home's interior as it appeared during the Lincoln funeral held in Springfield.<sup>37</sup>



(See illustrations 4 through 6 in Bearss, Report, LIHO.) Mr. and Mrs. Lucien Tilton had been renting the house since the Lincolns left Springfield, and most of the furnishings in the 1865 illustrations belonged to them. A newspaper account at the time of Lincoln's funeral (see p. 38) and the large number of furnishings which were purchased from the Lincolns by other Springfield residents indicate that the Tiltons purchased very little furniture from the Lincolns. Lincoln's secretary, bed, a marble-topped table, a whatnot, and a chamber set are the only items which the account specified they purchased. Both the secretary and bed appear in the stereoscope views.

Although these views were taken four years after the Lincolns left Springfield, it is possible that the wallpaper and floor coverings remained unchanged. (See pp. 145-150 for separate discussions of wallpaper and floor coverings.) The carpet pattern in the stereoscope view is very similar to the pattern shown in the Leslie's Illustrated 1861 sketches of the parlors.

In the William Waud Collection at the Library of Congress, Prints and Photographs Division, are three drawings of the Lincoln home and one of the Globe Tavern also made at the time of Lincoln's funeral.<sup>38</sup> See illustrations 4 through 7. One shows the front and back parlors, draped in honor of the funeral; two are uniden-

tified. The placement of windows and doors, however, suggests that illustration 5 is the front guest bedroom or downstairs sitting room and that illustration 6 is Lincoln's bedroom.

#### RECORDED FURNISHINGS - FIRST FLOOR

In this section on recorded furnishings all information, unless otherwise noted, was found in the Lincoln Home Files at the Illinois State Historical Society Library. As a large body of material comes from this source, only when an item has been directly quoted is it footnoted. Most of this material has been duplicated and is also under accession file no. 1 at the Lincoln Home National Historic Site, Springfield, Illinois.

Well-documented pieces are listed first. Those with strong associations are listed in the section that follows. The material is arranged alphabetically by object.

#### LINCOLN HOME FURNISHINGS WITH STRONG DOCUMENTATION

##### BOOKS:

##### Books Known to Have Been Owned by Abraham Lincoln:

Lincoln Books, Oldroyd Collection, The House Where Lincoln Died, Washington, D. C.

Acts and Resolutions Passed at the First Session of the Thirtieth Congress of the United

States, printed by Ritchie and Hess, printers, Washington, 1848, paper bound, inscribed four times "A. Lincoln," catalogue no. 3303.

The Great Indian Chief of the West or, Life and Adventures of Black Hawk (H. M. Rulison, Philadelphia, 1856), brown cloth, catalogue no. 3524.

Lincoln Books at the Library of Congress, Rare Books Division:

John G. Baldwin, Party Leaders (New York: D. Appleton and Co., 1855).

The National Portrait Gallery of Distinguished Americans (Philadelphia: D. Rice and A. N. Hart, 1856) 5 vols., I-IV, with inscription "A. Lincoln."

Scrapbook on Law and Politics and Times (Lexington, Kentucky: A. W. Elder, 1855), presented to Lincoln in 1855 by his friend George Robertson.

Samuel Kirkham's English Grammar (Cincinnati, 1828).

Other References to Books Owned by Abraham Lincoln:

The following is a tentative list of works Lincoln owned before leaving Springfield, based on four works: David C. Mearns, Three Presidents and Their Books (1955); M. L. Houser, The Books That Lincoln Read (1929); M. L. Houser, Lincoln's Education and Other Essays (1957); and Rufus Rockwell Wilson, What Lincoln Read (Washington, D. C., 1932). At this time, there is no complete study of the books owned by Lincoln.

Angell  
Anon.

Limitations in Equity  
Wealth and Worth

1856

Bailey, N.	Negro Equality (Scrapbook)	
Baily, W.	Unity of God	
Baldwin, J. C.	Flush Times of Alabama and Mississippi	
Beecher, E.	Riots at Alton	
Benton, Thomas H.	Thirty Years' View	
Blanchard, R.	Business Man's Assistant	
Blackstone, Wm.	Commentaries on the Laws of England	
Browne, C. C.	Aretemus Ward: His Book Holy Bible Psalms	1818
Burke, Edmund	Essay on the Sublime and Beautiful	
Burns, Robert	Poetical Works	
Campbell, Wm. W.	Life and Writings of DeWitt Clinton (New York, 1849). Inscribed on title page: "A. Lincoln -- Springfield, Ill., Nov. 19, 1860."	
Chandler, Mary G.	Elements of Character	
Channing, William Ellery	Works, 3 Vols.	1858
Chitty, J.	Treatise on Pleading and Parties to Action	
Cook, E.	Complete Poems	
Croker, C.	Popular Songs of Ireland	
Dalrymple, Sir J.	Great Britain and Ireland	
Day, J.	Introduction to Algebra	
Dean	Medical Jurisprudence	
Drake, B.	Life of Black Hawk	1856
Flint, Timothy	First White Man of the West	
French, J.	The True Republican	
Gibbon, Edward	History of the Decline and Fall of the Roman Empire	1839
Gibson, Robert	Theory and Practice of Surveying	
Gilman, C.	The Illinois Conveyancer	
Goldsmith, Oliver	Miscellaneous Works	
Goodloe, D. R.	The Southern Platform	
Greenleaf, S.	Treatise on the Law of Evidence	

Hallam, Henry	View of...the Middle Ages	1837
Halleck, Fitz-Greene	Poetical Works	
Hickey, W.	Constitution of the United States	
Hitchcock, E.	Religious Truth Illustrated from Science	
Howells, W. D. & Hayes	Life of Abraham Lincoln	1860
Illinois	Revised Laws (1829, 1841, 1843, 1845)	
Indiana	Revised Laws (1824)	
Kirkham, S.	English Grammar	1828
Knox, Rev. V.	Elegant Extracts	
Lanman, C.	Dictionary of the United States Congress	
Lincoln, A.	Address at Cooper Institute	
Lincoln, A.	Negro Equality (Scrapbook)	
Lincoln-Douglas	Political Debates	
Livermore, G.	Historical Research...Negroes as Slaves, as Citizens, and as Soldiers	
Lowe, A. T.	The Columbian Class Book	
Mitchell, Donald G.	Fudge Doings	
Neilson, W.	Syntax of the Greek Language	
Olmsted, D.	Introduction to Astronomy	
Paley, W.	Works	
Parker, Theodore	The Effect of Slavery on the American People	1858
Poe, Edgar Allen	Tales	
Pope, Alexander	Poetical Works	1839
Reed, A. C.	Life of George Washington	
Scripp, John Locke	Life of Lincoln	1860
Shakespeare, Wm.	Dramatic Works	
Sheppard, F.	Constitutional Textbook	
Simpson	Euclid	ca. 1835

Story, Joseph	Commentaries on Equity Jurisprudence	
Sumner	Republican Party	
Thayer, W. M.	The Pioneer Boy	
Webster, N.	An American Dictionary	1858
Webster, N.	Dictionary for Primary Schools	1833
Worcester, J.	History, Ancient and Modern	
Young, Edward	Night Thoughts	

Books Known to Have Been Owned by Mary Lincoln:

Collection of Mary Edwards Brown

Queens of England (LIHO 983); Novella (Present location unknown);  
Arithmetic (Present location unknown)

These works were acquired from Mary Edwards Brown. According to Mrs. Brown, they belonged to her great-aunt, Mary Todd Lincoln. According to the Catalogue Card No. 983, the Queens of England book is signed with a signature "Mary Lincoln, 1860," which does not match other known Mary Lincoln signatures, and there is another discrepancy in that the book's publication date is 1861. According to James Hickey, the Mary Lincoln signature is authentic and Mrs. Lincoln was often inconsistent on dates. She purchased four copies of this book.

Springfield Purchases

Two books purchased by the Lincolns in Springfield from Irwin and Co. on December 31, 1846, are: Eliza Leslie's Directions for Cookery in Its Various Branches (20th edition, Philadelphia,

1844) and Leslie's The House Book or A Manual of Domestic Economy for Town and Country (8th edition, Philadelphia, 1845).

#### Oliver R. Barrett Collection

Two books listed in the 1952 Oliver R. Barrett Auction Collection Catalogue are:

Mary G. Chandler's The Elements of Character (Boston 1858), black cloth, inscription "Mary Lincoln" came from Mrs. C. Smith's attic.

T.B. Read's The Female Poets of America (Philadelphia, 1852), full stamped leather, inscribed "Mary Lincoln."

#### Miscellaneous Written References to Mrs. Lincoln's Books:

According to Rufus Wilson's What Lincoln Read, Mrs. Lincoln subscribed to The Southern Literary Messenger.<sup>39</sup> The Lost and Found; or Life Among the Poor was given to Mary Todd Lincoln in 1860.<sup>40</sup>

Emilie Todd Helm recalled that during her visit to the Lincolns in 1854-1855 her sister Mary was reading the poems and novels of Sir Walter Scott.<sup>41</sup>

#### CHAIRS:

Side Chairs, Set of six, mahogany, mahogany veneer and oak (LIHO 1116, 1117, 1118, 1119, 1120, 1121)

These chairs were acquired in 1974 from the Historical Society of Pennsylvania as part of a collection which once formed the Lincoln Memorial Collection.<sup>42</sup> In 1886, S.B. Munson, Secretary of

the Lincoln Memorial Collection, began procuring artifacts for the purpose of a public display. The collection was on display at 94 Market Street in Chicago from 1887 to 1894. In 1894, the collection was sold by the Stan V. Henkels auction house.<sup>43</sup> Louis Clark Vanuxen and his son-in-law, William Potter, purchased many pieces from the collection. When Vanuxen died in 1904, one-half of the collection and an heir's share went to Potter. Potter persuaded the remaining heirs to present the collection in 1914 to the Historical Society of Pennsylvania, where it remained until 1974.

According to the Henkels Catalogue, lot numbers 1594 to 1599, listed as "Six antique mahogany chairs with tufted haircloth seats," as well as lots 1592, "an antique mahogany side table, with white marble top (marble broken)," 1593, "large French plate mirror, gilt frame," and 1600, "large Axminster rug," were all obtained from Allen Miller of Springfield who bought them from Lincoln at his February 1861 sale. The catalogue entry states that the furniture was accompanied by an affidavit of the Miller family attesting to its authenticity. An affidavit in the files was written by Mr. and Mrs. Lafayette Smith, neighbors of both the Millers and Lincolns, which confirms that the Millers bought the furnishings listed above. The description of the rug, however, differs in the affidavit which describes it as a "plush



hearth rug." The latter description, being older, is probably more accurate. A line drawing in the Henkels Catalogue depicts one of the chairs and the table which further identifies them. These chairs are also identical to four side chairs which appear in the 1861 Leslie's drawings of the east and west parlors. These six side chairs are among the best documented pieces of Lincoln furniture known today.

A close examination of the chairs reveals that they are each marked on the top of the inside front rail with numbers. Identifying the members of a set in this way was a standard cabinetmaking practice. In this instance, the numbers range from I through XI which suggests that there was a set of at least twelve.<sup>44</sup> Chairs were commonly bought in sets of twelve. A signed bill of sale by Abraham Lincoln to Dr. Samuel H. Melvin shows that Dr. Melvin also bought six chairs at the February 1861 sale.<sup>45</sup> Dr. Melvin's chairs may have been the remaining members of this set.

Rocking Chair, Caned Seat and Back (LIHO 47)  
Side Chair, Caned Seat (LIHO 28)

The rocking chair, purported to be Mrs. Lincoln's sewing chair, and the side chair are two items acquired by the Lincoln Home in 1929 from Elizabeth (Mrs. F. P.) Ide. These items were stated by affidavit to have belonged to Mrs. Lincoln. Their Lincoln provenance is logical; however, when objects change hands several

times, there is a greater chance of the original item being separated from its documentation. In this case, the artifacts appear to be the ones discussed in the affidavits.

Mrs. Ide purchased these items from a Springfield antiques dealer, Lucy Rhea, who collected Lincoln Home furnishings. Mrs. Rhea purchased the furnishings from Annie Kavanaugh, the daughter of Hugh Gallagher, expressman for J. Hough's cabinetmaking shop. Annie Kavanaugh wrote the affidavit. In her statement about the rocking chair dated August 21, 1926, she claimed:

...on one occasion when Mrs. Lincoln visited at the home of Hugh Gallagher she identified this rocking chair by saying "that is the little rocking chair that I rocked my babies in" and that affiant was present and heard Mrs. Lincoln make this remark; that said rocking chair came into the possession of affiant's immediate family on the occasion of Mrs. Lincoln refurnishing her home some years prior to 1861.

The affidavit for the side chair has not been located; however a list of items acquired from Mrs. Ide, which includes this chair, states that it was accompanied by one. Also, according to this list, two other cane seated side chairs "of the Lincoln period" were acquired from Mrs. Ide because of their similarity to the Lincoln one. An examination of the catalogue cards shows a pair of chairs (LIHO 26 and 27) to be those chairs. They have been mistakenly catalogued, however, as also having a history of

Lincoln ownership. An examination of the chairs shows that they are not from the same set as the one with a Lincoln history (LIHO 28).

Furthermore, there is a possibility that chairs in the style of LIHO 28 were not available at the time the Lincolns lived in Springfield. These chairs were factory made, inexpensive, and very popular during the 1870s. The earliest suggested date for this style is 1865.<sup>46</sup> Although dating according to style is not conclusive, until further evidence becomes available, this chair (LIHO 28) should not be exhibited in the Lincoln Home.

Fancy Painted Chairs (LIHO 59, 66, 77, 79, 92, 98, 1061, 1190)

A set of eight rush seated painted fancy chairs has been returned to the Lincoln Home by at least four different sources, each with a possible history of Lincoln ownership.

In 1958, Mrs. Elizabeth Pasfield of Springfield donated two fancy chairs (LIHO 59 and 66). At the time, Richard Hagen, Historical Consultant for the Division of Parks and Memorials, wrote Mrs. Pasfield saying:

The chairs are absolutely identical to four other Hitchcock chairs, Catalogue Nos. 77, 79, 92, 98, which have been in the house for some time;...this makes them doubly important to us because they help to establish the authenticity of the chairs we had previously.

Hagen's use of the word "authenticity" implies that these chairs, as well as the set of four previously acquired, were Lincoln chairs.

The files on these chairs are incomplete. Only one letter was located which referred to the Pasfield gift and no information was found on the other four chairs.

In 1976, two chairs (LIHO 1061 and 1062) and two couches (LIHO 1059 and 1060) from the Oldroyd Collection at Ford's Theater were transferred to the Lincoln Home. The rush bottomed fancy chair (LIHO 1061) from this collection is identical to those chairs previously acquired by the Lincoln Home.

According to Charles H. Coe's Descriptive Catalogue of the Oldroyd Collection, the rush bottomed chair (LIHO 1061) was presented to the Oldroyd Collection by Mr. and Mrs. L. H. Coleman who bought it from the Lincolns in 1861.

The chair also appears in the stereoscope view of the Oldroyd Collection taken in 1885.

Although the evidence on six of these chairs is very slim, the history of the Oldroyd chair appears reliable and its similarity to the other chairs suggests that all are from a set owned by the Lincolns.

An eighth chair (LIHO 1190), identical to LIHO 1061, was acquired by the Lincoln Home in 1983. Its history, although not complete, indicates that it was originally a Lincoln chair. The donor was Dr. Kane Zell, of Glen Arbor, Michigan. His affidavit dated June 9, 1983 reads:

In 1855 or 1856, Mrs. Lincoln refurnished the Lincoln home. At that time a number of dining chairs were taken from the home to the Lincoln-Herndon Law Office, where they remained until Mr. Lincoln went to Washington as President.

My great-grandmother, Mrs. Caroline Kane, lived on South Second Street on or adjacent to the present site of the Illinois Supreme Court Building. She and her family were close friends of Lincoln's law partner, Billy Herndon.

When Lincoln went to Washington, Billy Herndon asked Mrs. Kane if she would like to have one of Mr. Lincoln's chairs. On her agreement, the chair, first used in the Lincoln home and later in the Lincoln-Herndon Law Offices, was given to Mrs. Kane by Billy Herndon.

Upon Mrs. Kane's death, the chair went to Judge Charles Filo Kane of Springfield. Upon Judge Kane's death in 1918, the chair went to a cousin, Mr. Henry Kane Tully, of New York City. It remained in his possession until 1946. At Mr. Tully's death, the chair went to Dr. Kane Zelle of Springfield, the great-grandson of Caroline Kane. The chair has been in the possession of Dr. Zelle since that date, except for a period of time when the chair was displayed at Hugh Garvey's Lincoln Museum on Eighth Street, near the Lincoln home.

Rocking Chair, mahogany, upholstered in black haircloth

This chair does not appear in the stereoscope view taken of the

Oldroyd Collection in 1885,<sup>47</sup> but Coe's 1896 Inventory of the Oldroyd Collection states:

Rocking Chair, black haircloth, mahogany; a favorite with Mr. Lincoln. Sold by him in 1861 to Miss Lydia Rockhill, of Springfield, Illinois.<sup>48</sup>

Oldroyd himself (in an interview) mentions that he acquired the chair from "some dressmaking sisters named Rockhill who purchased it at the Lincoln sale in 1861."<sup>49</sup>

In 1896, the Oldroyd Collection was housed in the House Where Lincoln Died (Petersen House) on 10th Street, Washington, D. C. The present location of the chair is not known, although the National Park Service acquired the Oldroyd Collection in the early 1930s. Presumably the chair was separated from the collection between 1896 and 1930. Since Oldroyd purchased the chair directly from the Rockhill family, who were residents of Springfield at the time of Lincoln's sale, its provenance appears reliable.

CLOCKS:

E. Howard and Co. Wall Clock (LIHO 54)

The Lincoln Home acquired the E. Howard and Co. Wall Clock in 1953 from Minnie Smith Johnson, Mary Todd Lincoln's niece. According to Mrs. Johnson, the wall clock was given by Abraham

Lincoln to his brother-in-law, Clark M. Smith, just before his departure for Washington. The E. Howard Company introduced this model of clock about 1857.<sup>50</sup> It is illustrated in their 1874 catalogue (reprinted in 1972 by The American Clock and Watch Museum).<sup>51</sup> The clock was intended to supply jewelers, railroad stations, dispatcher's offices, and other areas needing a large, durable and reliable clock.

Although the history of this clock indicates it was owned at one time by Lincoln, it is not a very plausible item for him to have placed in his home. A clock such as the Kegwin and Alsop one, or a French clock, would be more in keeping with the taste displayed by the Lincolns' other furnishings. The possibility that Lincoln purchased this clock for his office or that it was a presidential gift is a more likely explanation for Lincoln's ownership of this large regulator clock. The fact that he gave the clock to his brother-in-law, who owned a store, suggests he may have had the store in mind as a possible location for the clock, when he made the gift.

Kegwin and Alsop Clock (Present location unknown)

The Historical Society's catalogue record on this clock indicates it contains a paper label identifying the clock as one manufac-

tured by Kegwin and Alsop of Springfield who were in business during Lincoln's residence there.

According to the Lincoln Home Files, at the Illinois State Historical Society Library, the clock was returned to the Lincoln Home by gift of Mr. H.D. Holt of Dunedin, Florida. He had acquired it from Emily Jackman Dawson, along with an affidavit (a copy of which is now in the Lincoln Home Files at the Illinois State Historical Society Library) signed by her October 19, 1960, giving the Dawson family history of the clock:

...That my husband [Walter Lincoln Dawson] always stated that the above mentioned clock was purchased by his father [Charles Dawson] at an auction in which some of Mr. Lincoln's household possessions were sold when he moved from Springfield to the White House.

The identification of the clock as a Springfield make manufactured between 1840 and 1860, and Dawson's position as both a Sangamon County resident and client of Lincoln's tends to confirm the family history that Dawson purchased it at the Lincoln 1861 sale.

HALL STAND:

Hall Stand (LIHO 51)

A combination hat and umbrella stand was presented to the Lincoln Home in 1950 by Mrs. Bert Wheeler, the granddaughter of Dr. Newton



Bateman, a friend of Lincoln's and State Superintendent of Public Instruction 1859-1862 and 1864-1874. According to the Bateman family tradition, Lincoln offered this friend his choice of the furniture before the 1861 sale. Bateman selected the hall stand and there is some evidence that Bateman also chose a hall chair which accompanied the stand. An article in Lincoln Lore (No. 1318, July 12, 1954) on "Chairs used by the Lincolns" listed the following item:

Bateman -- Springfield Hall Chair: Newton Bateman purchased from Mr. and Mrs. Lincoln a hat tree and hall chair. The hat tree was returned to its former location in the Lincoln Home at Springfield but the tall attractive hall chair apparently did not accompany it.<sup>52</sup>

#### LIGHTING DEVICES:

The Lincolns' purchases in Springfield indicate that they used both candles and lamps. On April 16, 1844, Mrs. Lincoln purchased two lamps from Irwin & Co. for \$1.50 and on November 29, 1849, the Lincolns purchased a wall lamp from J. Bunn & Co. A wall lamp appears in one of the Waud drawings, ca. 1865 (See illustration No. 5).<sup>53</sup> It is not clear from the drawing which room is illustrated. The placement of doors and windows indicates the room shown may be either the south front bedroom or the sitting room.

## Girandoles<sup>54</sup>

The Leslie's Illustrated drawings of the double parlor and sitting room show girandole sets on every mantelpiece and do not indicate any other lighting devices in those rooms. The Lincolns, however, did purchase several lamps as mentioned above. The available accounts of the Lincoln family purchases at local Springfield stores show that for the winter and spring of 1859 the Lincolns purchased an average of four pounds of candles per month. (See pp. 114-118 for a listing of the Lincolns' numerous candle purchases.) These purchases indicate a regular usage of candlelight in the Lincoln home.

Two sets of girandoles, one of which is now at the Lincoln Home, have a history of Lincoln ownership.

Girandoles, (LIHO 150-152), a set consisting of two single-arm candleholders and one three-stick candleholder

Stylistically, these girandoles are appropriate for the period and they are very similar to those on the mantel in the Leslie's Illustrated drawing of the Lincolns' front parlor. The provenance of these girandoles indicates that they were originally owned by the Lincolns.

They were given by Mr. and Mrs. John Herndon of Springfield to the Lincoln home in 1964. According to the Herndon family, the

girandoles had been given by Mrs. Lincoln as a farewell gift to Mr. and Mrs. Stephen Smith before the Lincolns left for Washington. The girandoles became part of an inheritance Mrs. Kate Herndon received from Nettie Smith, daughter of the Stephen Smiths. John Herndon then inherited them from his mother, Mrs. Kate Herndon. A newspaper article in a 1927 Bloomington Pantograph pictures the girandoles and outlines this history. John Herndon signed an affidavit dated March 8, 1965, also recounting the history.<sup>55</sup>

Mary Edwards Brown, grandniece of Mary Todd Lincoln, signed an affidavit on May 2, 1925, which outlined the history of another girandole set. She stated:

....when preparing to leave Springfield for Washington, Mr. Lincoln presented them [girandoles] to Mrs. Mary Black Remann, a friend and neighbor of the Lincoln family. That upon the death of Mary Black Remann, they came into the possession of her daughter, Miss Mary Julia Remann, and, upon her death, into the possession of the affiant, Mary Edwards Brown [niece of Mary Julia Remann].

The provenance appears reliable; however, the location of this girandole set is unknown.

MIRRORS:

Mirror (LIHO 1115)

This mirror was one of nine items purchased by Mr. Allen Miller of Springfield from the Lincolns at their 1861 sale. These fur-

nishings were accompanied by an affidavit dated April 10, 1886, written by Mr. and Mrs. Lafayette Smith, also Springfield residents who verified the Miller history of these items. (See pp. 53-55, 72-73, 138 for discussion of other Miller furnishings.) The mirror then became one of the Lincoln artifacts acquired by the "Lincoln Memorial Collection" in 1886. In the 1894 Henkels auction catalogue of the Lincoln Memorial Collection, the mirror was described as a "Large French-plate mirror, gilt frame." This mirror was later donated to the Historical Society of Pennsylvania (1914) and purchased by the National Park Service for the Lincoln Home in 1974. This mirror appears to be the one shown in the 1861 Leslie's Illustrated drawing of the Lincolns' sitting room, above a two-drawer sewing table.

#### SECRETARY-DESKS:

##### Secretary-Desk (Location unknown)

The available evidence, outlined below, indicates the original Lincoln home secretary was one of the furnishings purchased by the Tiltons, the family who rented the Lincoln home after the Lincolns moved to Washington. An account written at the time of Lincoln's funeral in Springfield mentions the secretary in the back parlor as one of the few original Lincoln pieces left in the

house. (See p. 38 for full account.) It is also illustrated in a stereoscope view of the Tilton parlor taken at the time of the funeral.<sup>56</sup>

A comparison of the secretary that appears in the Tilton stereoscope view with the one in the Leslie's Illustrated drawings (with some allowance for artistic license in the latter) indicates they are the same piece of furniture. Both the drawing and the stereoscope view show a large piece of furniture, with a deep desk top and curved side supports on the base. The location of this secretary is unknown; however, the Tiltons moved to Chicago from Springfield and their belongings are believed to have been destroyed in the Chicago Fire.

#### SEWING BASKETS:

##### Sewing Basket (LIHO 278)

Information found on the catalogue card states that the basket belonged to Mrs. Lincoln. The provenance was not included on the card. However, an affidavit found in Accession File No. 1, signed on May 2, 1925, by Mary Edwards Brown [who was the granddaughter of Elizabeth Todd (Mrs. Ninian Edwards), Mary Lincoln's sister] lists a sewing basket. It is Item No. 6 of 26 items she lists and the entry reads "work basket of Mrs. Abraham Lincoln."

LIHO 278 is very likely the basket which Mrs. Edwards mentions. Several items from Mrs. Edwards' list are now located at the Lincoln Home (the sewing basket and a few pieces of furniture). Other identifiable items on the list, such as the tablecloth used at the Lincolns' wedding, were acquired by the State. (See Appendix II for complete list.) The Illinois State Historical Society Library also has two sewing baskets with a history of ownership by Mary Lincoln.

#### SOFAS:

Pictorial and written evidence show that the Lincolns had at least two sofas in their home at the time of Mr. Lincoln's election.

Two sofas appear in the 1861 Leslie's Illustrated drawings of the Lincoln parlors, and one of the newspaper's correspondents who visited the Lincoln home in 1860 recorded that he sat on a sofa in the parlor while talking with Mr. Lincoln. (See p. 35 for a full account.) One of the Lincoln sofas was new a few months before the Lincolns moved to Washington, according to a letter written by Mrs. Lincoln, who expressed concern about the storage of belongings they left behind.<sup>57</sup>

Four sofas and one lounge have a history of being associated with the Lincoln home. While it is possible that all of these sofas

were owned by the Lincolns (assuming they bought new ones and discarded old ones over the years), it is unlikely they would have gone through so many. The best documented sofa is in the Chicago Historical Society. Affidavits, beginning with the purchaser who attended the 1861 Lincoln sale, trace it to the Gunther Collection and the Chicago Historical Society. (See pp. 71, 85-86, 87, 91-92, 98, 105 for discussions of Lincoln furniture, including this sofa, at the Chicago Historical Society.)

Sofas (LIHO 1059, 1060)

The following entries from Charles Coe's 1896 Descriptive Catalogue of the Oldroyd Lincoln Memorial Collection briefly present the provenance of two sofas from the Oldroyd Collection, now at the Lincoln Home. One of the sofas (LIHO 1059) was described:

No. 2. Sofa, black haircloth mahogany; 6 ft. 9 in. long, scroll ends. This was the first sofa owned by the Lincoln family, and was purchased by Mr. Lincoln when he commenced housekeeping in Springfield, Illinois in 1844. When he broke up housekeeping, previous to his departure for Washington in 1861, it was sold to Miss Lydia Rockhill, of Springfield.

It also appeared in the 1885 stereoscope view of Oldroyd's Collection. This sofa was catalogue no. 4495 of the Ford's Theatre Collection (purchased as part of the Oldroyd Collection in 1926) before its transfer in 1977 to Lincoln's Springfield home.

Sofa (LIHO 1060) described in 1896 by Coe:

No. 3. Sofa, black haircloth, solid rosewood; 5 ft. 3 in. long; a more modern pattern than the preceding, regarded by the family as a choice parlor piece. Sold by Mr. Lincoln in 1861 to the father <sup>59</sup>of Richard S. Burch, Springfield, Illinois.

This sofa was catalogue no. 4496 in the Ford's Theatre Collection.

Lydia Rockhill and Burch were both Springfield residents contemporary with the Lincolns. According to a letter written by Mary Lincoln (May 29, 1862), the Lincolns left some of their belongings, including a sofa, with William S. Burch, father of Richard Burch. Mrs. Lincoln wrote, "I see by the papers that Mr. Burch [William S. Burch] is married---we have some pieces of furniture still remaining at his house....The sofa, at Mr. Burch's was new, a few months before we left...."<sup>60</sup> Mrs. Lincoln's description of the sofa as "new" would correspond with the one from the Oldroyd Collection. It is in the rococo revival style, the newest fashion for the 1850s and 1860s. Mr. Burch's marriage may have been the occasion for his purchase of this sofa.

Both Oldroyd sofas have fairly strong histories of Lincoln ownership; however, neither resembles the sofas illustrated in Leslie's 1861 drawings of the parlors. Several explanations may account for this. The north wall of the sitting room was not



pictured and a sofa may have been against that wall. There is also the possibility that the Presidential candidate was given a sofa as a gift, and the sofa was never used.

Sofa, mahogany, serpentine, arched top rail with a fan shaped design in center (Chicago Historical Society, Accession No. 1920. 246)

This sofa, covered in "mohair cloth," was bought at the Lincoln 1861 sale by J. M. Forden, a neighbor of Lincoln's. In 1887, it was sold by J. M. Forden to George W. Forden, who, in 1888, sold it to Charles F. Gunther. Affidavits signed by both Fordens accompanied the sofa. This sofa is one of the best documented pieces of furniture from the Lincoln Home. Its similarity to the sofa illustrated in the Leslie's drawing of the back parlor suggests that the sofa was in this room before the Lincoln sale. (See Appendix I for a copy of the affidavit, and Plate VIII.)

Lounge,<sup>61</sup> single arm, with turned legs (LIHO 13)

This sofa was acquired from Julius Kuecher in 1953. Kuecher stated in a notarized affidavit that he inherited it from his father, John B. Kuecher, a Springfield resident and contemporary of Lincoln's. The family tradition about the sofa as described by Julius Kuecher (and also mentioned later in another affidavit by his nephew, Robert Watson Kuecher, see Appendix IV) is that Lincoln gave the sofa to Kuecher in 1861 before his departure for

Washington. The Kuecher provenance appears reliable, for the sofa descended directly in the Kuecher family from father to son.

A note on the catalogue card states that this sofa was specially made for Lincoln; the source of this note is not mentioned however, and there are no unusual features about the sofa to suggest it was specially made. Sofas of this style and description were made between 1840 and 1875 by furniture factories. Standard sizes ranged from six feet to six feet six inches long. The Kuecher sofa measures six feet seven inches (according to the catalogue card). It is the largest of the standard sizes. One inch is not a significant enough difference to confirm that the sofa was specially made.

TABLES:

Side Table (LIHO 1114)

Two tables with a strong claim to LIHO provenance were returned to the home from the "Lincoln Memorial Collection" (see p. 53 for history of the Lincoln Memorial Collection). The 1894 Henkels catalogue of the sale of the Lincoln Memorial Collection provides the earliest identification of these tables. The catalogue described the tables and summarized their history. The first table listed, Number 1592 (LIHO 1114), was described as "An Antique Mahogany Side Table with white marble top (Marble broken)."<sup>62</sup> The

same table was pictured with the caption "Antique Mahogany Table from Lincoln's Parlor." The Lincoln Memorial Collection acquired the table and several other furnishings (see pp. 53-54, 65-66, and 138) from Allen Miller, a Springfield neighbor of the Lincolns. According to an affidavit written by other neighbors, Mr. and Mrs. Lafayette Smith (April 10, 1886), the Millers purchased these items at the Lincolns' 1861 sale.

The Henkels catalogue also recounted the following story told by the Miller family about the table (Henkels Number 1592 - LIHO 1114):

As Mr. Miller was about to take them from the Lincoln residence, Mr. Lincoln requested that the table and one of the chairs remain, as he had some very important writing that he must attend to before leaving Springfield. Consequently, the very last writing that Mr. Lincoln did before leaving Illinois was upon this identical table and seated in one of these chairs.

The Miller history is supported by the fact that this table is very similar to the one shown in the Leslie's Illustrated drawing of the front parlor (see illustration No. 1).

#### Work Table (LIHO 1123)

Table No. 1603, an "Antique Mahogany work table, with pedestal base and two drawers," came from J. M. Forden, a Springfield resident who acquired them at the Lincolns' 1861 sale. According

to the accompanying affidavit,<sup>63</sup> the table was purchased by Forden, and remained in Forden's possession until 1887 when it was acquired by the Lincoln Memorial Collection.

Forden signed the affidavit as did several others who attested to his truthfulness. The work table went on to become a part of the Lincoln Collection owned by the Historical Society of Pennsylvania (see p. 54), and is now in the Collection of the Lincoln Home (LIHO 1123). This table, with its tapered pedestal and bracket feet, closely resembles the one pictured in the Leslie's Illustrated drawing of the Lincolns' sitting room. The resemblance confirms the Forden history.

#### Walnut Tete-a-Tete Table and Walnut Table (Washstand)

Two other tables were listed in the 1894 Henkels sale catalogue but their locations are now unknown. No. 1604 was listed as an "antique walnut tete-a-tete table," also owned by J. M. Forden. No. 1605 was listed in Henkels catalogue as a "walnut table, from the bedroom of Abraham Lincoln," evidently used as a washstand. This table was purchased by E. Figueri from Mr. and Mrs. Lincoln in 1861. See pp. 129-131 for discussion of lot 1602, a mahogany bureau from the same source.

#### Card Table (LIHO 29)

This table has a strong Lincoln provenance because it was ac-

quired by the Lincoln Home from the granddaughter of Mary Lincoln's sister, Frances Jane Todd (wife of Dr. William S. Wallace). Frances Todd Wallace Bulkley made the following statement about the table, June 24, 1965:

After my grandmother's death (Frances Wallace), August 14, 1899, my father received a shipment of personal belongings which had been in my grandmother's home in Springfield. My older sister, Elsie Lincoln Wallace, (now deceased), was given several pieces. I was told, since I was her namesake, the card table (pictures enclosed) belonged to me, together with a miniature portrait painted on ivory of my grandmother. The portrait depicts her holding her first child, Elizabeth, who died in infancy. I was also told the table was given to my grandmother by her sister Mary when the Lincolns moved to Washington. In our home, it was always referred to as the "Lincoln" table.

The card table was a fairly common furniture form often used in the hall or sitting room as a side table and occasionally for the same purpose in the dining room. Its presence in a home did not necessarily indicate that the family owning it played cards.

#### Drop-Leaf Table (LIHO 25)

The drop-leaf walnut dining room table was acquired for the Lincoln Home from Mrs. F. P. Ide. (See pp. 55-57 and 93 for discussions of other items acquired through Mrs. Ide.) Mrs. Ide purchased the table from a Springfield antiques dealer, Lucy Rhea, who, in turn, had bought it from Annie Kavanaugh. Mrs.

Kavanaugh inherited the table from her father, Hugh Gallagher, a Springfield resident from 1855 until his death in 1897. In an affidavit written August 21, 1926, at the time of Mrs. Ide's purchase, Mrs. Kavanaugh explained the Gallagher family tradition about the table. The following excerpts from the affidavit outline this history of the table:

...the said Hugh Gallagher...from the year 1855 to 1865 was associated with Jack Hough, the leading furniture dealer of Springfield, Illinois during that period. Affiant further says that the family of Abraham Lincoln bought much furniture for use in their home on the northeast corner of Eighth & Jackson Streets in Springfield, Illinois from the said Jack Hough and that many of the articles of furniture replaced by the said furniture so purchased was sold or given by Mrs. Lincoln to the said Hugh Gallagher and remained in his possession until his death. Affiant further says that the drop-leaf, waxed, walnut table purchased in August 1924 by Mrs. Francis P. [sic] Ide from Mrs. Lucy Rhea was purchased by the said Mrs. Rhea from me;...it came into the possession of my immediate family on the occasion of Mrs. Abraham Lincoln refurnishing her home...some years prior to 1861; that she then bought new furniture for her dining room; that the said drop-leaf, waxed, walnut table ...had...been used for a number of years in the Lincoln home as her dining room table....

#### Sewing Table (LIHO 46)

This two-drawer pedestal table was given to the Lincoln Home in 1956 by the family of Mrs. Harrison Blankmeyer. According to a statement by Mrs. Blankmeyer, the table was originally owned by

Lincoln. Lincoln gave the table to Benjamin Burch in return for Burch's assistance in crating furniture before the Lincolns' departure for Washington. The table descended in the Burch family to Benjamin's granddaughter, Mrs. Eunice Moorehead. Mrs. Moorehead then gave the table to Dr. Harrison Blankmeyer in return for professional services. A letter dated February 12, 1926, from Mrs. Moorehead in the Lincoln Home Files, at the Illinois State Historical Society Library, confirms Mrs. Blankmeyer's story.

Stylistically, the Blankmeyer table closely resembles the sewing table mentioned above from the Lincoln Memorial Collection and the one pictured in the Leslie's Illustrated drawing. Because the Lincoln Memorial Collection table has a stronger history of ownership (it went directly from the original purchaser into the Lincoln Memorial Collection with an affidavit), the Lincoln Memorial Collection table (LIHO 1123) should be placed on display in the sitting room, and the Blankmeyer table used as a side table on the second floor.

#### ARCHEOLOGICAL EVIDENCE:

A wide range of mid-to-late nineteenth century artifacts were excavated from old privy pits at the Lincoln Home.<sup>64</sup> The records that document these excavations have been transferred from the

State to the Lincoln Home, but the records do not distinguish among artifacts according to period of manufacture and use. Some of the ceramic shards, however, are identifiable and it is possible to say which ceramics and glass could date from the Lincoln period.

Transfer printed Staffordshire, creamware, and blue-edged ironstone could be examples of Lincoln household ware. Plain white ironstone--some with decoration in relief, one dish cover with an acorn knob handle, some marked by Bridgewood and Clarke of Burslem--also was found. The large number of plain white ironstone shards, including pieces of plates, covered dishes, cups, and chamber sets, indicates the presence of at least one set of ironstone.

The luster tea leaf pattern of ironstone now on display in the Lincoln Home has been said mistakenly to be a pattern owned by the Lincolns. The pattern dates from about 1880 and reached a height of popularity around 1890. The justification for the acquisition of this china appears from the available records to be based on a tea leaf pattern soap dish (LIHO 335) thought to have been Lincoln's.<sup>65</sup> This soap dish is stamped underneath: "Royal Ironstone/Alfred Meakin/England." The Alfred Meakin potteries were not founded until 1873, and this particular mark was used by the company in the 1890s.<sup>66</sup>



Parts of pressed glass goblets (hexagonal and octagonal fluted) and tumblers (hexagonal fluted) were in the privy excavations (see LIHO Acc. No. 23, list by Ruthanne Heriot). Most table glassware owned by middle-class families in America at this time was pressed glass.

Five Intact Bottles (LIHO 301-305) of the type in use at mid-century for medicine, castor oil, blacking, etc., were also found in the privy. (See purchase records of the Lincoln family, pp. 98-100, 112-119, 142-144 for examples of bottled items the Lincolns bought.)

Wooden Tooth Brush<sup>67</sup>; Two Broken Combs; Three Brush Handles; Curved Top of an Alabaster Pin Box; Tortoise Shell Pin; Six Amber Glass Marbles; Four All-Slate Pencils<sup>68</sup>

These items were found during the archeological investigations and are of an appropriate date to have belonged to the Lincolns.

FURNISHINGS ASSOCIATED WITH LINCOLN BUT NOT WELL DOCUMENTED

CHAIRS:

Plank Bottom Wooden Side Chairs: Two, one in the Lincoln Home Collection (LIHO 1062) and the other in the Oldroyd Collection. LIHO 1062 was transferred to the Lincoln Home from Ford's Theater. One chair, a painted, plank bottomed side chair, with flowers on the top rail and back splat, is said to have been used in the

Lincoln dining room. The second, a matching plank bottom chair, remained in the Oldroyd Collection (location unknown in 1980). Coe's 1896 Descriptive Catalogue of the Oldroyd Collection described them as "No. 9. Chair, common wooden, used by the family in the dining-room, Lincoln homestead." "No. 10, chair, same as the preceding." No other documentation has yet been found, and Coe gives no information as to how Oldroyd acquired the chairs or from whom. Although these chairs may be Lincoln associated chairs, the evidence to support that claim is very slim and, therefore, they should be listed only tentatively with those items having a much stronger provenance.

Rocking Chair, Upholstered in Black Horsehair (LIHO 38)

This chair should not be listed with the original Lincoln home items; however, it has a Lincoln association. According to the Pickarel family of Springfield, this chair was "Lincoln's favorite" when he visited them. The chair was donated to the Home by a Pickarel grandson, George Pasfield.

Rocking Chair, ladder back with splint weave seat (LIHO 126)  
Rocking Chair, upholstered in black horsehair (LIHO 94)

The ladder back rocking chair was acquired for the Lincoln Home by the National Society of Colonial Dames of America through the antiques dealer Lucy Rhea. The upholstered rocking chair was also acquired from Mrs. Rhea. According to information found in

the files, the catalogue card for the ladder back chair and a letter and statement from Mrs. Rhea concerning the upholstered rocker, both pieces of furniture had accompanying affidavits attesting to their authenticity. These affidavits have not been found. Both chairs supposedly belonged to the Lincolns and the ladder back in particular to Mrs. Lincoln. Without the affidavits, this association cannot be confirmed.

Rocking Chair, caned seat and caned panel on back with four turned spindles and curved crest rail above panel (possibly cherry) ca. 1840-1860. Located at Tuskegee, Alabama, in Booker T. Washington's study at The Oaks

This chair was given to Tuskegee Institute (TUIN #24) with a history of having been owned by Lincoln. No records have as yet been located to substantiate this claim. The chair, however, is identical to the pair shown in Frank Leslie's Illustrated Newspaper (March 9, 1861) drawing of the Lincolns' sitting room and no other chairs of a similar design have yet been found with a Lincoln history of ownership. It is of an appropriate style and date to have come from Illinois at that time. It has been refinished and one piece of wood on the seat has been replaced.

Rocking Chair (LIHO 56)

The files on this chair appear to be incomplete. It was acquired by the State from Mrs. Chester Dudley Tripp. The chair came with a history of having belonged to Mr. Lincoln. No affidavit is

mentioned on the catalogue card and no correspondence relating to this chair has been located. There is not enough information on this chair to confirm the Lincoln association.

Rocking Chair (LIHO 64)

The files on this chair are incomplete. The State purchased the chair in 1956 from Mrs. Charity Coe Wood. The tradition which accompanied the chair is that it belonged to Mr. Lincoln. No affidavits or correspondence have been located in the files. There is currently not enough information available to determine Lincoln authenticity.

Side Chair, balloon back (LIHO 787)

This chair was donated to the Lincoln Home in 1973 by the Estate of Myrtle Burke. In 1970, Mrs. Burke wrote to the Department of Conservation to offer the chair and at that time outlined its history. She stated:

Many years ago, I purchased from a dealer in Jacksonville, Illinois, whose name as I recall was Caldwell, a chair that had been in Mr. Lincoln's home in Springfield when he left there to go to Washington to become President  
....

This chair has been in my possession for a great many years (close to 45 or 50) and was purchased by me from a young man who dealt in antiques and he had acquired it from Mrs. Lincoln's nieces, to whom Mrs. Lincoln had left the house and contents upon her death. In my childhood these nieces had an exchange or gift shop....

Mrs. Burke's account is questionable for several reasons. No balloon back side chairs appear in the Leslie's Illustrated drawings. The side chairs which do appear are of an earlier style, the late Empire. Mrs. Lincoln did not leave the house and contents to her nieces. After Mr. Lincoln's death, she quit-claimed her rights to the house in favor of her sons. The majority of the Lincoln furnishings were sold before the Lincolns' removal to Washington. Only a few pieces of furniture purchased by the Tiltens remained in the house and these furnishings appear to have been destroyed in the Chicago fire.

Mrs. Lincoln, however, did give away specific items to her family and it is possible such a chair was given to a niece. Unfortunately, Mrs. Burke was not able to provide further details and the evidence is not sufficient to support the claim that the chair came from the Lincoln Home.

Side Chair, balloon back (LIHO 260)

This side chair does not have a Lincoln home association. It was owned in Springfield by Mrs. Lincoln's sister and for this reason has been mentioned in this plan. It was donated to the Lincoln Home by Mrs. T. F. Mahoney (Olivia Reid Mahoney). The chair supposedly came from the home of Mrs. Lincoln's sister, Mrs. Ninian Edwards.

Side Chairs, Pair, Hitchcock style, stencilled gold lines  
(LIHO 31 and 32)

These chairs were acquired from Mrs. Hugh Morrison who believed they were originally in the Lincoln and Logan law office. It is possible, however, that they were originally in the Lincoln Home. As the Lincolns purchased new furniture, it is possible that old furniture was taken to Lincoln's law office. No affidavits or correspondence were found in the files. These chairs appear to be two of four Hitchcock chairs Mr. Hagen refers to as Lincoln chairs.

Chairs with Lincoln Association in Other Collections:

Greenfield Village and Henry Ford Museum

The Ford Museum has a collection of furnishings acquired by Henry Ford in 1930 from Ben and Dick Wilton, descendents of Harry Wilton, U. S. Marshal of the Southern District of Illinois. In his capacity as a U. S. Marshal, Mr. Wilton would have known Mr. Lincoln, the lawyer. In fact, among the documents listed in Henkels' sale catalogue (1894) from the Lincoln Memorial Collection is a note written by Abraham Lincoln of an order obtained by Wilton for the Southern District dated June 17, 1843, made in the case of Walter R. Bush vs. Robert Allen.

According to the Ford Museum, the furniture in their collection from the Wiltons includes a mahogany empire card table with

acanthus carving on the lyre pedestal, a shelf clock by John Birge, Bristol, Connecticut, six cane seated side chairs and six late empire mahogany side chairs with acanthus carved front legs, decorative carving on the splat and top rail, and hair cloth seats.

According to an article on Lincoln chairs in Lincoln Lore (No. 1318, July 12, 1954), there were also two rocking chairs in this collection as well as six other unidentified pieces of furniture. There is no supporting documentation (such as affidavits or bills of sale) for this furniture and without additional evidence, this collection cannot be authenticated as having come from the Lincoln home.

#### Chicago Historical Society-Lincoln Home Furnishings

The Chicago Historical Society has a large collection of furnishings, more than half of which are chairs which have a history of coming from the Lincoln home in Springfield. Unfortunately, little of this furniture is well documented. The following is a list of those items (not already mentioned in the section on well-documented furnishings) with their accession numbers and provenance, if known:<sup>69</sup> (Also, see illustrations 8 and 9.)

Chair, small, painted brown, XA-2260, Charles F. Gunther Collection. The Gunther Collection was acquired by the Historical Society in 1920, and was not well documented.

Chairs, pair, slat backed, pine with black stain, XA-2257. Charles F. Gunther Collection. These chairs were reportedly from the Lincoln home kitchen, but were not well documented.

Chairs, four, side, rosewood with heart shaped back, Acc. No. 1920.242 a-d, Charles F. Gunther Collection. In addition to the absence of documentation, these chairs do not resemble any in the March 9, 1861, Leslie's drawings of the parlors or sitting room.

Chair, rocking, mahogany, Acc. No. 1920.243, Charles F. Gunther Collection. No documentation.

#### FOOTSTOOLS:

The Leslie's Illustrated drawing of the Lincolns' front parlor shows two upholstered footstools. One, supposedly original, footstool is now at the Lincoln Home; however, unlike those which appear in the drawing, it is caned rather than upholstered.

#### Caned Footstool (LIH0 48)

According to the catalogue card, this footstool has a history of belonging to Mrs. Lincoln. No provenance was mentioned on the card. A letter located in Accession File No. 1, dated August 19, 1960, however, states that a footstool belonging to Mrs. Lincoln was donated by Emily C. Paschal along with a "furniture doily." At that time, Richard Hagen, Historical Consultant, wrote to



thank Mrs. Paschal. A caned sewing chair (LIHO 47), with which this footstool would be appropriate, also has a history of belonging to Mrs. Lincoln. Without further information, however, the footstool cannot be authenticated as an original Lincoln item.

#### LAMPS:

##### Lamp, Coal Oil (Present location unknown)

A note in the Lincoln Home files, Illinois State Historical Society Library, outlines the history of a coal oil lamp supposedly owned by the Lincoln family. According to an affidavit (not found in the files but mentioned in the note) signed by Mrs. Ellen McCarthy Kent, Mrs. Cornelius McCarthy, Mrs. Kent's mother, purchased the lamp at the Lincolns' 1861 sale. It was the McCarthy family's first lamp. Mrs. Kent inherited the lamp and presented it to Bess Giblin Earseman. Cornelius McCarthy was living in Springfield at the time of the sale and could have attended it. In the 1860-1861 Springfield City Directory, he is listed as a laborer living west of Rutledge and First Streets, north of Miller. The McCarthy family history seems reliable; however, the location of the lamp is currently unknown.

#### MIRRORS:

##### Mirror (Chicago Historical Society) Accession No. 1960.100

This mirror is said to have been purchased from the Lincolns by Colonel George H. Harlow in 1869 and hung in the Lincoln Home

when George Harlow (Secretary of State of Illinois, 1873-1881) rented the Lincoln home in that same year. George Harlow's daughter, Georgia Harlow Whitacre, signed an affidavit, April 18, 1933, stating the above family history and that the mirror was purchased from her by Mrs. Jacob Baur. In 1958, Mrs. Whitacre's sister, Susan Harlow, signed another affidavit confirming the above story. Mrs. Baur gave the mirror to the Chicago Historical Society in 1960.

The provenance does not account for the mirror from the time the Lincolns moved out of the house in 1861 (and sold most of their belongings) until 1869 when the Harlow family moved into the house. Without further information, this mirror cannot be confirmed as an original Lincoln Home piece of furniture.

#### MUSIC BOXES:

##### Music Box (Illinois State Historical Society Collection)

A mid-nineteenth-century music box descended in the family of Frances Todd Wallace, Mary Todd Lincoln's sister. According to Mrs. Wallace's granddaughter, Frances W. Patteson, her mother, Mrs. Patteson was given the music box by her Aunt Mary Lincoln. Copies of correspondence relating to this artifact are found in LIHO furnishing files. There is no evidence to indicate that this music box was located in the Lincolns' Springfield home.

## PEDESTAL STANDS:

### Pedestal Stand (LIHO 1098)

This stand was transferred from the Lincoln Museum Collection at Ford's Theatre. According to their records (where it was catalogue no. 3202), the stand was one of the furnishings Oldroyd acquired from Miss Lydia Rockhill, a Springfield milliner and dressmaker, who had purchased these items at the Lincolns' 1861 sale. See pp. 59-60 and 69 for discussions of other artifacts purchased by Miss Rockhill.

The major points of this history can be verified. Miss Rockhill is listed in the Springfield 1860-1861 Directory, and the stand is mentioned in the 1896 inventory of the Oldroyd Collection. The available evidence, however, indicates this oak stand is not the one Oldroyd purchased from Miss Rockhill.

According to the Oldroyd 1896 inventory, the Rockhill stand was of black walnut. In addition to this discrepancy, the oak stand dates stylistically from the late nineteenth century. Oak pedestal stands with applied decoration were popular household items between 1890 and 1910. It is very unlikely that this stand was made before 1890 and, therefore, it could not have been in Lincoln's Springfield home.

Since the provenance for the Rockhill stand appears reliable, the oak stand was probably miscatalogued at Ford's Theatre, in place of the original stand, which now cannot be located.

In the stereoscope view of the Oldroyd Collection taken in 1886, a stand may be seen and it is emphasized by a number. This may be an illustration of the Rockhill stand.

#### SECRETARIES AND DESKS:

##### Secretary-Desk (LIH0 6)

The secretary-desk, now in the Lincoln Home back parlor, descended in the family of Ninian Edwards, brother-in-law of President Lincoln. It was acquired from Mary Edwards Brown who inherited the desk from her father Albert S. Edwards who, in turn, had received it from his father Ninian Edwards. According to family tradition, Ninian Edwards purchased the desk from Mr. Lincoln prior to his departure for Washington.

There is a discrepancy in the records about where the desk originally was located. Mr. Lincoln's office and his home are both referred to in different documents. An affidavit (in the LIH0 accession files), sworn to by Mary Edwards Brown, May 2, 1925, states that "the desk to which this certificate is attached... used by him [Mr. Lincoln] in his law office in said City of

Springfield." Unfortunately, Mrs. Brown does not clearly identify the desk. She could be referring to another piece of furniture. A memo written in 1956 by Richard Hagen, Historical Consultant, to William Allen (Lincoln Home files in the Illinois State Historical Library) concerning acquiring funds for the purchase, however, reiterates the story that the desk was used in Lincoln's law office. Hagen more clearly identifies the piece of furniture by referring to it as a secretary-bookcase. The price mentioned is also the same as that paid by the State for the Edwards secretary-desk. The confusion arises because the purchase order states that the secretary-desk was used in the Lincoln Home and the catalogue card for this item contains the same story. Based on the evidence mentioned above, the logical conclusion is that a mistake was made on the purchase order and then was repeated at the time the collection was catalogued, which took place in 1973, many years after the original purchase. This secretary also does not resemble the one shown in the Leslie's drawing or the one in the Tilton stereoscope view.

Secretary, walnut, in two sections (Chicago Historical Society, Accession No. 1920.240)

No known provenance, said to have been used in Lincoln's home.

Desk and Chair (Chicago Historical Society, Accession No. 1920.920 a-b)

No known provenance, said to have been owned by Lincoln while he

was studying law at Vandalia and retained by him until his departure from Springfield.

Pine Desk (Oldroyd Collection, Ford's Theatre, Washington, D. C., Catalogue No. 3206)

According to Ford's Theatre records, this desk has a history of having been used by Mr. Lincoln at Springfield. No documentation, however, exists to support this claim.

SOFAS:

Sofa, transitional style between late Empire and Rococo (LIHO 5)

No material could be located in the files at the Illinois State Historical Society Library or at the Lincoln Home beyond information found on the catalogue card. The sofa was returned to the home by direct descendents of the Reverend Dresser (the donor's name was not on the card), who sold the 8th Street house to Lincoln. According to information on the catalogue card, the sofa was one Dresser left in the house at the time of the Lincolns' purchase. A problem with this history is that the sofa would have been in the latest style at the time the Dressers sold the house. Although possible, it does not seem logical that the Reverend Dresser would leave behind a brand new piece of furniture.

According to James Hickey, Curator of the Lincoln Collection, Illinois State Historical Library, the sofa was donated by Mrs.

Clifford Conry, a Dresser descendent, as a piece of furniture which had descended in the Dresser family of Springfield. The sofa had not been in the Lincoln house when the Lincolns lived there. The sofa should not be labeled as a Lincoln piece of furniture.

#### STEREOSCOPE:

##### Stereoscope (LIHO 273)

This stereoscope is identified by a metal label on the front which reads "A. Beckars, Patent April 7, 1857, Jas. Lee, N.Y. manufacturer." According to an affidavit signed by Annie E. Kavanaugh, June 16, 1926, the stereoscope was sold by Jack Hough to Mr. Lincoln in 1860 and acquired by her father, Hugh Gallagher, in 1868. Mrs. Kavanaugh does not state how Hugh Gallagher obtained it. However, it is possible that it was one of the items stored in Springfield by the Lincolns and Hugh Gallagher could have acquired it from Mrs. Lincoln after Lincoln's death. When Mrs. R. W. Ide, Jr. acquired the stereoscope was not noted in the records. Many of the Kavanaugh Lincoln items passed through the hands of a Springfield antiques dealer, Lucy Rhea; however, in this instance, it is not clear whether or not Mrs. Ide purchased the stereoscope directly. It is not mentioned in any of the existing Lucy Rhea correspondence. Mrs. Ide sold the stereoscope to the Lincoln Home in January 1954.

Since there are several unexplainable gaps in the provenance of the stereoscope, the Lincoln association must be considered unconfirmed though plausible.

TABLES:

Table, occasional, marble topped, Renaissance Revival Style (LIHO 55)

According to the catalogue card, this table was acquired by the Lincoln Home from Mrs. Bertha Gilmore of Massapequa, New York, with a history of Lincoln ownership. The records for this table are incomplete; however, stylistically, it is doubtful that the table dates prior to 1865. Therefore, its Lincoln history of ownership (at least during the Lincolns' Springfield period of residence) is not likely. No further information was located in the files.

Table (Present location unknown)

In 1953, Richard Hagen, Historical consultant to the Division of Parks and Memorials, purchased a whatnot, a table, and four pieces of china with Lincoln histories from L.C. Handy Studios in Washington, D. C. (see p. 101 for discussions of other items). According to Mrs. Evans, one of the owners of Handy Studios, these items were originally purchased by Isaac Strohm of Springfield at the 1861 Lincoln sale. Mrs. Evans purchased these fur-



nishings from W. English who provided her with their history. No affidavits appear to have accompanied this purchase.

Proof of the provenance of these items is not strong. They changed hands several times, and they did not have any accompanying supportive data, such as a bill of sale or an affidavit by the original purchaser. Unless further information is found, these items should not be labeled as original to the Lincoln home.

Table, Center, Mahogany and Marble (Present location unknown)  
Information about the provenance of this table is incomplete. According to the files, this table was given to the Lincoln Home in 1942 by the Volicos family. At the time it was given, the table was said to have been in the Volicos' family for fifty years.

Table (Present location unknown)

Another table is mentioned in the Lucy Rhea correspondence as having come from the Lincoln Home; however, the records do not indicate that this table was ever acquired for the Home. It is included here in case further information becomes available. In a letter (July 17, 1934) written by Mrs. Rhea to Virginia (possibly Virginia Brown, caretaker at the Home), Mrs. Rhea lists a number of items with a Lincoln association that she wishes to

sell, several of which were acquired for the Home (see pp. 55-57, 75-76, 80-81, 93-94, 103-104, 125-127, and 132-133) with the apparent exception of this table and two pieces of fabric. In the 1934 letter, Mrs. Rhea described the table as "oval marble top walnut table formerly property of Mrs. Lincoln now in Springfield Art Association and filled with old glass cabinet on top that had formerly belonged to Lincolns." A statement by Mrs. Rhea listing four pieces of furniture was also found in LIHO Accession File No. 1. Two of the pieces of furniture were supposedly from the Lincoln Home, a rocker (LIHO 94), which was purchased from Mrs. Rhea, and the above mentioned table. In this statement, Mrs. Rhea adds the information that an affidavit was available although she does not say from whom. Another rocker (LIHO 126) was also purchased from Mrs. Rhea according to the LIHO catalogue and an accompanying affidavit states that it originally belonged to Mrs. Lincoln. The history of this table is not sufficient to state whether or not it was ever originally located in the Lincoln home.

#### WHATNOTS:

##### Whatnots

Two whatnots are visible in the 1861 Leslie's drawings of the Parlor. The one in the northwest corner of the parlor may be a triangular shaped corner whatnot, although its shape is not clear

from the drawings. One mid-nineteenth-century wall whatnot (now found in the Lincoln Home), a corner one in the Chicago Historical Society, and a whatnot owned by the Melvin family have a history of Lincoln ownership. The whatnot with the strongest Lincoln provenance is one owned by the descendants of Dr. Samuel Houston Melvin, a Springfield doctor, who originally purchased the whatnot from the Lincoln sale, February 9, 1861, for \$10.00. The bill of sale signed by Abraham Lincoln was kept by the family along with the whatnot and a wardrobe. For many years, this whatnot was on display at the Oakland (California) Municipal Museum, to whom it was loaned by Dr. Melvin's son, Henry Melvin.

The other whatnot (LIHO 24) now in the Lincoln Home was purchased in 1953 by the Division of Parks and Memorials on the recommendation of Richard Hagen. He found several items supposedly owned by Lincoln at an antique store in Washington, D.C., the L.C. Handy Studios, owned by Mrs. Mary H. Evans.<sup>70</sup> According to Mrs. Evans, she acquired the whatnot from W. English, who had bought it from Isaac Strohm of Springfield, who had purchased it from the Lincoln sale in 1861. Although Strohm does not appear in the 1860-1861 Springfield City Directory, he is listed in the 1850 census for Sangamon County, City of Springfield, as a 10-year-old boy.

The whatnot (Accession No. 1921.7) at the Chicago Historical Society also has inconclusive evidence in support of the claim that it came from the Lincoln home; however, it is the only known corner whatnot with a Lincoln history. The Historical Society acquired the whatnot in 1921 from a Miss Camille Henry of Chicago whose father, according to the Henry family tradition, purchased the whatnot from the Lincolns when they left for Washington.<sup>71</sup>

#### ACCESSORY FURNISHINGS

##### SPRINGFIELD STORE ACCOUNTS:

The following items are taken from the Lincoln family's accounts with Springfield stores.<sup>72</sup> Although the present location of these items is unknown, all would be appropriate for display at LIHO.

##### Irwin & Co.

May 21, 1844            Two Fire Screens

##### John Williams & Co.

May 27, 1851	1 Small Basket, Per Lady	\$ .23
Feb. 2, 1853	1 Pair Blankets	\$ 7.50
Feb. 9, 1853	1 Marseilles Quilt	\$ 6.50
May 17, 1856	2 White Chambers @ 1.25, Per Son	\$ 2.50
Sept. 3, 1856	1 Pair Shell Side Combs, Per Lady	\$ .50
Feb. 2, 1859	1 Watch Guard, Per Robert	\$ .15

Apr. 8, 1859	6 Bars Lead @ .05, Per Robert	\$ .30
Apr. 14, 1859	Flannel for Gun Cover, Per Robert	\$ .30
Aug. 23, 1859	6 French Towels (.35)	\$ 2.10

Corneau & Diller

Jan. 27, 1859	Hair Brush	\$ 1.59
May 21, 1859	Bottle Indelible Ink	\$ .25

C. M. and S. Smith & Co.

Jan. 17, 1859	1 Umbrella, Per Bob	\$ .75
Feb. 1, 1859	1 Paper Tacks, Per Son	\$ .10
Feb. 17, 1859	1 Set Knitting Needles, Per Son	\$ .05
Apr. 14, 1859	2 Paper Tacks @ .10	\$ .20
Apr. 19, 1859	1 Tuck Comb	\$ .75
Apr. 23, 1859	1 Table Cover, Per Lady	\$ 3.75
Apr. 30, 1859	1 Bowl, Per Bob	\$ .87
	1 Pitcher, Per Bob	\$ 1.25
May 6, 1859	6 3/4 yds. Table Linen @ .75, Per Lady	\$ 5.06
May 18, 1859	1 Water Bucket, Per Son	\$ .25
June 30, 1859	2 Paper Needles @ .10, Per Lady	\$ .20
July 12, 1859	1 Wash Bowl, Per Lady	\$ .50
July 20, 1859	1 Comb, Per Son	\$ .20
Aug. 6, 1859	1 Fine Comb, Per Lady	\$ .25
	1 Hair Brush	\$ .75
Aug. 18, 1859	1 Table Cloth, Per Lady	\$14.00
	1½ Doz. Napkins @ 4.25	\$ 6.30

Aug. 22, 1859	1 Pocket Knife, Per Bob	\$ 1.25
Aug. 23, 1859	6 French Towels @ .35, Per Robert	\$ 2.10
Sept. 6, 1859	1 Tidie, Per Lady	\$ 1.00
Sept. 7, 1859	1 Tidie, Per Lady	\$ 1.25
Sept. 8, 1859	1 Tidie Returned	\$ 1.00
Sept. 29, 1859	1 Parasol, Per Lady	\$ 3.00
Oct. 6, 1859	3 Paper Tacks @ .08 1/3	\$ .25
Dec. 2, 1859	2 Comforts @ .75	\$ 1.50

BASKET OF APPLES:

In an article entitled "Lincoln As I Knew Him," Charles S. Zane, a Springfield resident, recalled a visit to the Lincoln home. He recounted, "On reaching the house, we found a large basket of apples in the sitting room and were invited to help ourselves."<sup>73</sup>

VOLK BUST OF LINCOLN:

In an article in Century Magazine of December 1881, Leonard Volk recalled making a small bust of Lincoln and presenting it to Mrs. Lincoln in Springfield:

I was invited into the parlor and soon Mrs. Lincoln entered holding a rose bouquet in her hand, which she presented to me after the introduction; and in return I gave her a cabinet size bust of her husband, which I had modelled from the large one.

This bust appears in the Leslie's drawing of the front parlor, on the top shelf of the whatnot.

DINNERWARE, ETC.:

Lincoln Silver & Glassware: Six Silver Forks, Three Cut Glass Goblets, An Inkwell, and Sand Shaker; (Present Locations unknown)

According to an article in the Springfield Register dated November 9, 1923, these artifacts were exhibited in the window of the J.C. Klaholt & Co. jewelry store. A Mrs. Mae McKnight was offering them for sale. The newspaper printed the affidavit signed by Mrs. McKnight (November 9, 1923) which outlined the artifacts' history. Mrs. McKnight stated:

I...do hereby certify that the six silver forks, three cut-glass goblets, an inkwell, and sand shaker in my possession were purchased from Abraham Lincoln at the old Lincoln home in Springfield in 1861 when Mr. Lincoln sold his household goods and left for Washington, to become President of the United States.

I further certify that the aforesaid heirlooms were in the personal possession and use of Abraham Lincoln and members of his family, and that they were purchased from Mr. Lincoln by my grandmother, Mrs. Roxana McIntire, who originally had one dozen knives and forks and one dozen glasses. These heirlooms were handed down by my grandmother to my mother, Mrs. D.A. Nafew, and by her, to me.

The Lincoln provenance for these items appears to be well documented up to 1923. Unfortunately, the location of these items is presently unknown.

Lincoln Home Artifacts with Lincoln History of Ownership:

Ironstone Bowl (LIHO 193); Creamware Pitcher (LIHO 197); Transfer Printed Plate (LIHO 192); Leaf Shape Ironstone Serving Dish (LIHO 195)

These four pieces of china, supposedly from the Lincoln Home, were among the six items with a Lincoln provenance purchased in 1953 from L.C. Handy Studios in Washington, D. C. The history of the ownership of this china, as told by one of the owners of Handy Studios, Mary Evans, is that it was purchased at the 1861 Lincoln sale by Isaac Strohm, a Springfield resident. Strohm does not appear in the 1860-61 Springfield Directory, although he was listed as a 10-year-old boy in the 1850 Springfield census. No affidavits substantiate this story. The archeological evidence of china in use during the Lincoln period, however, shows evidence of these types of ceramics. Although this is not enough information to verify the Lincoln association with these ceramics, they are characteristic of ceramics in use at mid-century. The leaf shape serving dish is marked with the impress "J. Clementson," a mark in use by the Joseph Clementson Staffordshire potteries from 1839 to 1864.<sup>74</sup>

Hand Painted China Dinner Plate LIHO 196; Glass Pitcher with Painted Decoration LIHO 259; Abalone Shell LIHO 290; Abalone Shell LIHO 291

These items were given to the Lincoln Home in the 1920s by Logan Hay, according to a letter from Hay in the LIHO files. Hay was a member of a Springfield family who had been neighbors of the Lincolns. According to Mr. Hay, these items had all belonged to



Mrs. Lincoln. No affidavits or explanations of provenance were found to accompany the artifacts; therefore, they cannot at this time be authenticated as Lincoln items.

According to the catalogue cards for the shells, they were used to hold down Mrs. Lincoln's drapes. This history, however, does not seem likely; shells do not appear in the 1861 Leslie's Illustrated drawings and those drawings show the drapes just touching the floor. One visitor's account at that time mentions seeing shells on the whatnots. Displaying shells as knick-knacks on shelves is a more likely practice than using them to hold down drapes on the floor. Moreover, the additional length required for the draperies to be held down in this fashion would have been a costly luxury.

#### Pressed Glass Cake Stand (LIHO 255)

This cake stand was purchased from Mrs. Lucy Rhea in 1934. Correspondence from Mrs. Rhea prior to that time also mentions the cake stand. In a letter she wrote July 17, 1934, to Virginia [Brown], she described it as "Mrs. Lincoln's high glass cake stand."

The invoice states there was an accompanying affidavit; however, it is currently missing and the Lincoln provenance cannot be

stated absolutely. Although the cake stand cannot at this time be authenticated, it is likely that Mary Lincoln owned such an item.

#### LINCOLN FAMILY ARTIFACTS IN OTHER COLLECTIONS

Listed by owner with the provenance included, if known. Only those items have been included that could date from the Springfield period and have some documentation in support of their Lincoln association.

##### Collection of Mary Edwards Brown

Several Lincoln items were acquired in 1957 from Mary Edwards Brown, grandniece of Mary Todd Lincoln by the Illinois State Historical Society Library. These artifacts were accompanied by affidavits signed by Mary Edwards Brown stating that she inherited them from various family members:

One wool pink and yellow shawl (LIHO 744, a white shawl, with a pink ribbon and yellowed with age, has a history of having come from Mary Lincoln through Mary Edwards Brown and may be this shawl) formerly belonging to Mrs. Lincoln.

Lap robe, billfold, and penholder belonging to Abraham Lincoln.

##### Collection of James Hickey, Springfield, Illinois

Three daguerreotypes of Robert, Tad, and Willie Lincoln, believed to have been used in the Lincoln home.

Library of Congress, Washington, D.C.

A pair of daguerreotypes of Mr. and Mrs. Lincoln originally hung in the Lincoln Home in Springfield. A letter from Robert Todd Lincoln about a daguerreotype of his father affirms that these daguerreotypes were a pair hung in the Lincoln Home, "the daguerreotype was on the walls of a room in my father's house from my earliest recollection as a companion picture to that of my mother."<sup>75</sup>

Chicago Historical Society

A silver watch (Accession No. 1927.2), dating ca. 1850, was given to the Historical Society by Dr. Otto C. Schmidt. On the back of the watch is pasted a small piece of paper with the following inscription: "Springfield, July 31, 1858" and "A. Lincoln." The Historical Society records indicate no further known provenance.<sup>76</sup>

A pair of rubbers (Accession No. 1920.683 a,b.), ca. 1860, was acquired by the Historical Society as part of the Charles F. Gunther Collection with a history of Lincoln ownership.<sup>77</sup> The Historical Society Records do not indicate any known provenance. The rubbers are marked on the bottom "Boston Rubber Shoe" with an eagle holding a shield insignia beneath and the words "Goodyear's Patent."

Collection of John K. Lattimer, M.D., Sc.D., College of Physicians and Surgeons of Columbia University, New York, New York 10032.

A small leather (cowhide) trunk came up for sale in the early 1970s at Charles Hamilton's Auctioneers, in New York, where it was purchased by Nathaniel Stein from whom it was purchased by Dr. Lattimer.<sup>78</sup>

Articles (Location Unknown) Received from Robert Todd Lincoln by Mrs. G. J. Sinninger.

Margaret Sinninger was a good friend of Robert Todd Lincoln and her account should be considered reliable.<sup>79</sup>

These articles were offered to the Chicago Historical Society in January 1937. A copy of the correspondence listing the items was located in the Lincoln Home files, Illinois State Historical Society Library. Only those items which may have come from the Lincoln home in Springfield are included below. The correspondence lists:

Album given by Abraham Lincoln to Mary Todd. Shield on cover is engraved "A.L. to M.T." It has a brass clasp and is dated December 25, 1841. It is black leather, faded with age, and contains photographs taken during the Civil War of Abraham Lincoln, Mrs. Edwards, the Governors of many States, and many Generals of the Army.

Eyeglasses and case carried and used by Abraham Lincoln.

Baby picture of Robert Todd Lincoln, 3" x 2½" is old-fashioned book having small gold edge and the outside is covered with rose velvet.

Baby picture of Willie Lincoln framed the same as the baby picture of Robert Todd Lincoln.

Picture of George Washington, 26½" x 19½", which hung in the home of Abraham Lincoln. Painted by Gilbert Stuart, engraved by O. Pelton, published by Gordon Bill, Springfield, Massachusetts. The name Washington appears at the bottom.

Small engraving of the mother of Abraham Lincoln in a round oval frame.

Photograph of Herndon, law partner of Abraham Lincoln, with chromo frame. Picture was used in the Springfield home.

[Note that this information corresponds to information in one of the written accounts describing the home in 1867. J. Bliss mentions seeing a picture of Herndon hanging in the parlor. See pp. 40-41 for written account.]

Photograph of Robert Todd Lincoln framed in old chromo walnut and was used in the Lincoln home in Springfield, Illinois.

### Lincoln College, Lincoln, Illinois

Lincoln College acquired four Lincoln items from the family of John Kuecher. (See pp. 138-141 for discussion of Kuecher collection.)

China penholder and pen, 2" x 2½", acquired by Lincoln College through King Hostick from Robert Watson Kuecher, grandson of John Kuecher.

Lantern, black, tin, 4¼" x 4¼" x 11", for a candle, acquired by Lincoln College through King Hostick from Robert Watson Kuecher. Said to have been given by A. Lincoln to John Kuecher before the Lincolns moved from Springfield.

Plate, marked with lion, unicorn, and shield surmounted by crown and lion ("Lillet" under larger lion), reportedly owned by Mary Lincoln and given to Mrs. John Kuecher.

Carving set, including knife, fork, and sharpener, marked J.A. Henckel's Twin Works, Solingen, Germany. Acquired by Lincoln College through King Hostick from Robert Watson Kuecher.

Fuller-Werner Co., Milwaukee, Wisconsin

A photocopy of an article (found in LIHO Accession File No. 1), which appeared in Wisconsin Magazine, January-February 1924, pictures an elaborate wood burning stove, patented in 1849, which, according to the Fuller-Werner Co., was used by Lincoln in his Springfield home. The Fuller-Werner Co. acquired the stove through Mr. Jones, who purchased it in 1873 in Springfield. This provenance is, however, not conclusive because of the twelve-year gap between the time the Lincolns sold their belongings and Mr.

Jones' purchase of the stove. This stove is, however, very similar to the one shown in the Leslie's Illustrated drawing of the Lincolns' front parlor.

#### RECORDED KITCHEN FURNISHINGS

##### STOVE:

The Royal Oak cook stove now in the Lincoln Home Kitchen (LIHO 559), thought to have once been Mrs. Lincoln's, came back to the Home with several other items from the Oldroyd Collection. It has a well-documented history. The stove's provenance is described in the 1896 Descriptive Catalogue of the Oldroyd Collection by Charles Coe. He wrote:

Stove, cook; "Royal Oak," no. 9, manufactured by Jewett and Root, Buffalo, N.Y., 1855. This stove--an old-fashioned woodburner, with four lids--and a wide hearth,--was in use by the family previous to their departure for Washington. It is still in good serviceable condition. An accompanying affidavit made by the son of E. Kreigh, stove dealer, Springfield, states that an entry in his father's books shows that Mr. Lincoln<sup>80</sup> purchased the stove on the 9th of June, 1860.

The original affidavit appears to be missing; however, the stove is identifiable by a stamped manufacturer's mark, and the suggested history is plausible. Kreigh was a Springfield stove merchant and two checks for very small sums written by Mr. Lin-

coln in 1859 (see p. 119) to Springfield stove merchants, P.A. Dorwin & Co. (February 16, 1859) and D.J. Boynton (September 7, 1859) might indicate that his old stove was having repairs or worn parts replaced.

#### CUPBOARD:

There are written references to the presence of a kitchen cupboard during the Lincoln occupancy, although there is no known existing cupboard.<sup>81</sup> A reminiscence, told in connection with a cupboard in the (Chicago) Lincoln Memorial Collection, specified a pie cupboard in the Lincoln Kitchen:

There is an old cupboard--the sort your grandmother probably used. It is five feet high; has board doors and a strong lock. A gentleman who was a visitor to the Lincoln mansion in Springfield in the earlier days vouches for this:

In this cupboard, Mrs. Lincoln kept her pies, cakes, and preserves. On one occasion, company was expected. The cupboard was comfortably crowded with delicacies. The boys--Bob and Tad--went to the room in which the cupboard stood and gorged themselves with the contents, thus getting what you newspaper fellows would call a "scoop" on the company. Mrs. Lincoln thereupon ordered this lock to be placed on the cupboard, and she carried the key to the same up to the day the family left Springfield for Washington. (Article about the Lincoln Memorial Collection, Chicago Tribune, Monday, April 17, 1890.)



The cupboard in the Lincoln Memorial Collection, however, is clearly a wardrobe and probably was in one of the bedrooms. The reminiscence possibly refers to another cupboard.

Another newspaper article (in the Danville Commercial-News, Danville, Illinois, February 13, 1929) mentions a Lincoln cupboard and several pieces of china which belonged to a Mrs. Eugene Jackson, great-granddaughter of Maria Vance, who claimed to have been a cook in the Lincoln household.

Although there is some doubt among Lincoln scholars as to whether or not Maria Vance was a cook in the Lincoln household and how long she was employed, Robert Lincoln did pay her a visit in Danville in 1897, which suggests she was at one time associated with the Lincolns.<sup>82</sup>

According to the article, Maria Vance "helped pack the household goods and was given numerous articles as keepsakes, which are scattered now." A porridge set, bowl, saucer and pitcher, of "delicate design" were mentioned as well as a cupboard, which family tradition claimed was given to Maria as a wedding present. The cupboard was described as "old style 'safe' form" resting on a base.

For possible kitchen chairs, see pp. 53 through 60, the general section on Lincoln chairs. Possible kitchen china is discussed on pp. 101 through 104.

The following pages contain lists, in chronological order, of spices, foodstuffs, and a few kitchen utensils which the Lincolns purchased at nearby Springfield stores. These purchases would have been found on the Lincoln kitchen shelves.

KITCHEN PURCHASES:

Kitchen purchases listed in Pratt, Personal Finances of Abraham Lincoln:

Irwin

Feb. 21, 1853	1 4-Prong Fork	\$ 1.25
Mar. 24, 1853	½ yd. Oil Cloth @ .50	\$ .25
Mar. 30, 1853	5/8 yd. Oil Cloth @ .50	\$ .31
Mar. 1, 1855	½ lb. Tea @ 1.25, Per Son	\$ .63
July 21, 1855	½ lb. Gun Powder Tea @ 1.25, Per Son	\$ .63
Aug. 15, 1855	½ lb. Tea, Per Son	\$ .63
Nov. 26, 1855	1 Glass Lantern, Per Son	\$ 1.00
Jan. 23, 1857	½ lb. Tea @ 1.25, Per Son	\$ .62
Aug. 3, 1857	½ lb. Tea @ 1.25, Per Son	\$ .64
Aug. 20, 1858	1 lb. Tea	\$ 1.00

Aug. 21, 1858	1 Box Palm Soap 62 @ .07	\$ 4.34
	5 lbs. Java Coffee	\$ 1.00
	8 lbs. Sugar, Per Son	\$ 1.00
Sept. 11, 1858	5 lbs. Java Coffee	\$ 1.00
Sept. 25, 1858	5 lbs. Java Coffee	\$ 1.00
Oct. 16, 1858	9 lbs. Sugar	\$ 1.00
	5 lbs. Java Coffee	\$ 1.00

Corneau & Diller

Mar. 15, 1855	Sweet Oil	\$ .10
June 29, 1855	Bottle Vermifuge	\$ .25
July 6, 1855	1 # Cream of Tarter	\$ .60
	½ # Soda	\$ .10
	Soda Water	\$ .10
Aug. 10, 1855	1 Paper Horse Powder	\$ .40
Aug. 17, 1855	1 Paper Horse Powder	\$ .75
Oct. 31, 1855	1 # Cream of Tartar	\$ .60
	½ # Soda	\$ .10
Feb. 24, 1856	Sweet Oil	\$ .15
Jan. 29, 1857	Bal. on Gelatin	\$ .40
Feb. 11, 1857	Olive Oil	\$ .15
June 13, 1857	2 # Cream of Tartar	\$ 1.00
July 20, 1857	2 Bottles Extract Vanilla	\$ .70
Jan. 12, 1859	3 oz. Red Gelatin	\$ .60
	Isinglass	\$ .60
Jan. 27, 1859	2 Cakes Soap	\$ .50

Jan. 31, 1859	6 oz. Red Gelatin	\$ 1.00
	Cooper Isinglass	\$ .75
	1 # Cream of Tartar	\$ .50
Feb. 5, 1859	4 lbs. Starch	\$ .50
May 13, 1859	3 Cakes Soap	\$ .50
June 3, 1859	Bottle Brandy	\$ 2.00
June 7, 1859	Extract of Almond	\$ .35
June 13, 1859	Bottle of Brandy	\$ 2.00
Sept. 6, 1859	Bottle Dead Shot (Bedbug Remedy)	\$ .25
Dec. 23, 1859	Borax	\$ .05

C. M. & S. Smith

Jan. 4, 1859	10 lbs. Sugar @ .10, Per Son	\$ 1.00
Jan. 6, 1859	4 lbs. Star Candles @ .25	\$ 1.00
Jan. 8, 1859	1 Gallon C. Syrup	\$ 1.00
Jan. 10, 1859	8 lb. Turkey @ .10, Per Lady	\$ .80
Jan. 13, 1859	6 lbs. Crushed Sugar @ .16 2/3, Per Son	\$ 1.00
Jan. 14, 1859	5 Doz. Eggs @ .20, Per Son	\$ 1.00
Jan. 15, 1859	1 Gal. Syrup, Per Son	\$ 1.00
	11 lbs. Sugar	\$ 1.00
Jan. 25, 1859	1 Gallon C. Syrup, Per Son	\$ 1.00
	11 lbs. Sugar	\$ 1.00
Jan. 26, 1859	1 Box Blacking, Per Son	\$ .10
Jan. 31, 1859	6 lbs. Sugar @ .16 2/3, Per Son	\$ 1.00
Feb. 8, 1859	Paid for 3 Loads Wood, Per Bob	\$ 6.00

Feb. 10, 1859	A.L. to John Baker, Wood	\$ 1.75
Feb. 14, 1859	11 lbs. Sugar, Per Son	\$ 1.00
Feb. 24, 1859	11 lbs. Sugar, Per Son	\$ 1.00
	1 Gal. C. Syrup	\$ 1.00
	4 lbs. Star Candles @ .25, Per Son	\$ 1.00
Mar. 7, 1859	11 lbs. Sugar, Per Son	\$ 1.00
Mar. 10, 1859	5 lbs. Coffee @ .20, Per Lady	\$ 1.00
Mar. 19, 1859	10 lbs. Sugar @ .10, Per Son	\$ 1.00
	4 lbs. Candles @ .25	\$ 1.00
Mar. 28, 1859	32 lbs. Java Coffee @ .18, per Dyer Drayage	\$ 5.76
Apr. 4, 1859	4 doz. Eggs @ .10, Per Son	\$ .40
Apr. 6, 1859	$\frac{1}{2}$ lb. Tea, Per Son	\$ .50
Apr. 9, 1859	10 lbs. Sugar @ .25	\$ 2.50
	4 lbs. Star Candles @ .25	\$ 1.00
Apr. 14, 1859	1 Peck Potatoes	\$ .30
Apr. 21, 1859	10 lbs. Sugar @ .10, Per Son	\$ 1.00
	1 Box Cinnamon	\$ .15
Apr. 30, 1859	10 lbs. Sugar @ .10, Per Bob	\$ 1.00
May 6, 1859	6 lbs. Crushed Sugar @ .16 $\frac{2}{3}$	\$ 1.00
	4 lbs. Candles @ .25	\$ 1.00
May 11, 1859	10 lbs. Sugar @ .10, Per Son	\$ 1.00
May 20, 1859	$\frac{1}{2}$ lb. Star Candles @ .25, Per Bob	\$ .13
May 23, 1859	$\frac{1}{2}$ lb. Tea @ 1.00, Per Son	\$ .50
May 26, 1859	10 lbs. Sugar @ .10, Per Son	\$ 1.00

June 3, 1859	11 lbs. Sugar, Per Son	\$ 1.00
June 7, 1859	6 lbs. White Sugar @ .16 2/3, Per Bob	\$ 1.00
June 9, 1859	Salt for Ice Cream, Per Dyer	\$ .40
June 10, 1859	6 doz. Eggs @ .08 1/3, Per Son	\$ .50
June 17, 1859	11 lbs. Sugar, Per Bob	\$ 1.00
June 21, 1859	1 Paper Pepper, Per Bob	\$ .05
June 25, 1859	11 lbs. Sugar, Per Son	\$ 1.00
July 9, 1859	11 lbs. Sugar, Per Son	\$ 1.00
July 12, 1859	1 Box, Per Lady	\$ .25
	66 lbs. Soap @ .07	\$ 4.62
July 18, 1859	½ Ga. Vinegar @ .25	\$ .13
July 23, 1859	11 lbs. Sugar	\$ 1.00
July 25, 1859	22 lbs. Sugar	\$ 2.00
July 29, 1859	6 Chickens @ .15, Per Son	\$ .90
Aug. 2, 1859	1 Blacking Brush, Per Son	\$ .25
Aug. 4, 1859	2 Doz. Nutmegs @ .12½, Per Son	\$ .25
Aug. 16, 1859	11 lbs. Sugar	\$ 1.00
Sept. 9, 1859	6 lbs. Sugar @ .08 1/3, Per Lady	\$ .50
	4 lbs. Star Candles @ .25	\$ 1.00
	5 lbs. Java Coffee @ .20	\$ 1.00
	Nutmeg	\$ .10
Oct. 1, 1859	5 lbs. Java Coffee @ .20, Per Lady	\$ 1.00
	5 lbs. Sugar @ .10	\$ .50

Oct. 6, 1859	10 lbs. Sugar @ .10, Per Lady	\$ 1.00
	3½ lbs. Crushed Sugar @ .16 2/3	\$ .50
	3½ lbs. Pulverized Sugar @ .16 2/3	\$ .50
	1 oz. Nutmeg	\$ .15
	1 Bottle Lemon	\$ .25
	1 doz. Eggs	\$ .10
Oct. 7, 1859	1 Broom, Per Lady	\$ .25
Oct. 10, 1859	2 Barlow Knives @ .10, Per Self	\$ .20
Oct. 13, 1859	5 lbs. Java Coffee @ .20, Per Son	\$ 1.00
	1 Box Salt @ .25	\$ .25
Oct. 19, 1859	10 lbs. Sugar @ .10, Per Lady	\$ 1.00
	5 lbs. Coffee @ .20	\$ 1.00
	2 oz. Indigo @ .12½	\$ .25
	1 Bottle Lemon	\$ .25
Oct. 21, 1859	1 Box Cinnamon, Per Son	\$ .15
Nov. 12, 1859	10 lbs. Sugar @ .10, Per Lady	\$ 1.00
	4 lbs. Star Candles @ .25	\$ 1.00
Nov. 12, 1859	1 Box Blacking	\$ .10
	1 Paper Matches	\$ .15
Nov. 14, 1859	2 Brooms @ .30, Per Lady	\$ .60
	3 bu. Potatoes @ .40	\$ 1.20
	1 Bottle Lemon	\$ .25
	2 Boxes Cinnamon @ .12½	\$ .25
Dec. 1, 1859	12 lbs. Sugar @ .08 1/3, Per Lady	\$ 1.00
	5 lbs. Java Coffee @ .20	\$ 1.00
	2 lbs. Starch @ .12½	\$ .25
	2 Boxes Cinnamon @ .12½	\$ .25
	1 Cream Tartar	\$ .50
	1 Peck Turnips	\$ .08
	1 Bottle Extract	\$ .25
Dec. 2, 1859	1 Peck Apples, Per Lady	\$ .30
Dec. 31, 1859	9 lbs. Crushed Sugar, Per Son	\$ 1.00

Kitchen Purchases Found in: Lincoln Day By Day<sup>84</sup>

Feb. 22, 1849	3 yds. Check Cloth (Irwin)	\$ .75
Apr. 18, 1849	Paper & Oilcloth Shelf "Bordering" (Irwin)	\$ 6.03
May 7, 1849	Groceries, 6 3/4 Moreen and Piece of Binding .15 (Irwin)	\$ 4.62
May 29, 1849	7 lbs. Sugar	\$ .50
June 5, 1849	Sperm Candles (Bunn)	\$ 1.00
June 6, 1849	6 lbs. Sugar and Lemon Syrup (Bunn)	\$ 1.75
July 26, 1849	Scythe and Handle (Irwin)	\$ _____ ?
Sept. 4, 1849	7 lbs. Sugar (Bunn)	\$ .50
Sept. 5, 1849	Loaf Sugar (Bunn) Pound of Candles (Bunn)	\$ .50 \$ .40
Sept. 10, 1849	Broom (Bunn)	\$ .30
Sept. 18, 1849	Groceries (Irwin)	\$ 4.86
Sept. 20, 1849	Sundries (Bunn)	\$ 4.35
Sept. 29, 1849	½ Gal. Vinegar (Bunn)	\$ .13
Oct. 1, 1849	½ Gal. Vinegar (Bunn)	\$ .12
Oct. 9, 1849	Matches (Bunn)	\$ .13
Oct. 11, 1849	Sugar and Coffee (Bunn)	\$ 1.00
Nov. 14, 1849	Sundries, Per Maid (Bunn) Sundries, Per Maid (Irwin)	\$ 7.10 \$ .20
Dec. 19, 1849	Sugar (Bunn)	\$ .50



Jan. 15, 1859: Lincoln writes check \$50.91 to Condell Stockdale & Co. dry goods (p. 240 Chronology)

Jan. 18, 1854: Cough remedies (Diller's Day Book)

Feb. 16, 1859: \$2.16 to P. A. Dorwin & Co., tinware and stove merchants

June 3, 1859: \$2.00 Bottle of Brandy (Diller's Day Book)

June 13, 1859: \$2.00 Bottle of Brandy (Diller's Day Book)

Sept. 7, 1859: Lincoln writes check to D. J. Boynton, furnace and stove dealer, \$1.75 (p. 260)

Dec. 29, 1859: \$1.25 check to J. B. Fosselman, grocer (p. 267)

#### RECORDED FURNISHINGS - SECOND FLOOR

#### PICTORIAL:

After Lincoln's death, three Schreiber and Glover stereoscope views were taken of his bedroom as it appeared during the Tiltontons' residence.<sup>85</sup> They were entitled "Lincoln's Bedroom," "Lincoln's Bed," and "Lincoln's Bedroom Washstand." During tours of the house, the Tiltontons pointed out those pieces of furniture which they had purchased from the Lincolns at their sale in 1861. The Chicago Tribune on May 6, 1865, mentioned specific items, among which were a "heavy oaken bedstead" and "a chamber set."

These items were presumably among the Tilton furniture which was destroyed at their Chicago residence during the Great Fire in 1871.

From the same period as the Schreiber and Glover stereoscope views are a series of four drawings in the William Waud Collection at the Library of Congress.<sup>86</sup> They are of the Globe Tavern, the Lincoln parlors draped for the funeral, and two other rooms, presumably also in the Lincoln home. One of the latter illustrations, No. 6, may be Lincoln's bedroom. The placement of the windows suggest one of the front rooms and it seems most logical that the illustrator would focus on Lincoln's room. A draped table, empire chair, bureau, mirror, and small oval pictures appear in the illustration.

In this section all information, unless otherwise noted, was found in the Lincoln Home files at the Illinois State Historical Library.

#### BEDS:

Lincoln's Bed. According to the Chicago Tribune of May 6, 1865 (see p. 38), Lincoln's "oaken bedstead" was still in the house, having been bought by the Tilttons at the Lincolns' 1861 sale. The 1865 Schreiber and Glover stereoscope view of Lincoln's

bedroom confirms this account, showing what appears to be an oak bed. The oak grain is visible in the photograph. The only earlier evidence we have of Lincoln's bed is an 1860 visitor's account of sitting on a "high post bed," which description also fits the bed in the stereoscope view. This bed was probably among the Tilton furniture destroyed by the Chicago Fire of 1871.<sup>87</sup>

Four other Lincoln associated beds are known to exist. Presumably, the house would have contained five or six beds. In one instance Lincoln, in September of 1857, traded a "trundle bed" for a "cottage bedstead" from John Hutchinson's Furniture Factory. Lincoln paid \$11.00 for the new bed and received \$2.00 credit for the old one.<sup>88</sup> It was a common practice at the time to trade in old furniture when making a new purchase; therefore, other Lincoln home beds may yet come to light. The following is a brief analysis of five known Lincoln-associated beds.

#### Bedstead (LIHO 71)

The early nineteenth-century mahogany sleigh-type bedstead (LIHO 71) now in the Lincoln Home has a strong family history of Lincoln ownership. According to oral tradition, the bed was purchased by Colonel William Babcock of Canton, Illinois, from the Lincoln sale in 1861. The bed passed from Colonel Babcock to his

daughter, Elizabeth Ann Babcock, wife of William Henry Binnian, and was then passed down in the Binnian family to Samuel Binnian, a great-grandson of William Babcock.

Bedstead and Bureau, Illinois State Governor's Mansion

A second Lincoln-associated bedstead and a matching bureau were donated to the State in 1969 by the Donovan family of Lexington, Kentucky (now property of Illinois State Governor's Mansion). It is a Renaissance revival walnut chamber set. According to signed affidavits, the bed was bought by Mary Ticknor, who lived at the corner of Eighth and Jackson from 1868 to 1873, at a sale of furniture from the Lincoln home, "about 1872." She wrote in her affidavit (1938), "This bed was wider and longer than the ordinary bed, and had been used by Abraham Lincoln himself, and had been a part of Abraham Lincoln's household goods." Mary Ticknor sold the bed to a Miss Adele Mendenhall (Mrs. P.E. Karaker) who, in turn, gave it to the Donovans. Miss Mendenhall's affidavit states the bed came from the Tiltons. This bed is not pictured in the Schreiber and Glover stereoscope views, nor is it mentioned in the 1865 newspaper accounts of those Lincoln items still in the house. The bureau is, however, similar to one depicted in the Schreiber and Glover views which belonged to the Tiltons and was not a Lincoln piece of furniture.

The earliest affidavit, however, the 1938 one by Mary Ticknor, does not mention the Tiltons. In fact, a handwritten note on the affidavit reads, "Bought of some neighbor not direct of Lincoln's -- Think it was Mrs. R (?) or Mrs. Robinson a dresser with it but don't know what became of it."

The comment about the missing dresser suggests the possibility that this set is not the one which the Ticknors originally bought. Also, stylistically, the bed and bureau are more characteristic of furniture produced in the 1860s and 1870s, than earlier periods. The furniture, however, is all marked with the number "1" which might indicate that it was the first set in a production line and it may have been a presentation gift to President Lincoln just before his departure for Washington. On the basis of this latter theory, the State of Illinois has placed this set in the Governor's Mansion rather than the Lincoln Home.

Bedstead, Collection of Mr. & Mrs. Evans Cantrell

Another Lincoln Home-associated bedstead has recently come to light. According to Mr. and Mrs. Evans Cantrell, who now own the bed (it is currently being stored at Illinois State Historical Society Library), they bought it from the estate of a Springfield upholsterer, John Graham, who had received the bed from the widow of George Franklin Seymour (1829-1908), Protestant Episcopal Bishop of Springfield from 1878 to 1908.<sup>89</sup>

A letter written by Mrs. Seymour to Mr. Graham, in the possession of the Cantrells, states:

It is the veritable bed on which rested the Great Statesman Lincoln.

It was a gift to the Bishop when he finished and turned the old building into the "Episcopal Palace" at a cost of 10,000. It was considered a worthy offering to the Great Bishop.<sup>90</sup>

Mrs. Seymour also added that the Bishop used the bed for twenty-five years, which indicates he was given the bed some time around 1883, the year he moved into the "Episcopal Palace." In her statement to Mr. Graham, she claims the bed was slept on by Lincoln; she makes no mention of it coming from the Lincoln home.

A memorandum written March 5, 1951 by Virginia Stuart Brown, great-granddaughter of N.W. Edwards, and granddaughter of Albert Edwards, states that the Seymour bed originally belonged to the Ninian Edwards family. Virginia Brown wrote:

The only bed I ever heard of that was claimed to be Lincoln's in the Eighth Street House, was a four-poster owned by an upholsterer, John Graham. He went to Mrs. Albert Edwards some time before 1910 for an affidavit, which she refused to give as she knew that bed to be one owned by Mrs. Ninian Edwards, who had given it to Bishop Seymour<sup>91</sup> when the Edwards moved into a smaller house.

In all likelihood, this bed was slept in by Lincoln but it does not appear to have come from the Lincoln home.

Bedstead, the Lukins' Family, Springfield, Illinois

"A four-poster spool type, walnut bed" was mentioned in a newspaper article entitled "Lincoln Bed at Former City Home" in the Decatur Review, Decatur, Illinois, March 1, 1931. It descended in the Lukins family, having been purchased by Gregory Lukins, a friend of Lincoln as a young man, from Lincoln in Springfield. According to family tradition, Gregory Lukins went to Springfield from Petersburg to buy a bed and he called on Mr. Lincoln who agreed to sell him a bed the Lincolns did not need. Gregory was a descendent of Peter Lukins, a friend of Lincoln from his New Salem days. The description of this bed as "spool type" is similar to those beds with turned decoration which furniture catalogs of the mid-nineteenth century describe as "cottage bedsteads," at least one of which we know Lincoln bought. The oak bedstead of which we have a photograph can also be described as "spool type" and as a "cottage bedstead." The location of this bed is unknown.

COMMODES AND DAYBEDS:

Commode (LIHO 104) and Wicker Daybed (LIHO 80)

The mahogany commode, now in Mrs. Lincoln's bedroom, and the wicker daybed in the front guest room, are said to have been purchased (along with the chest of drawers previously mentioned)

from the Lincolns by Hugh Gallagher, expressman (associated with Jack Hough, furniture dealer) in 1858, according to an affidavit written by Gallagher's daughter, Annie Kavanaugh, in 1926.

Mrs. Kavanaugh's affidavits for the commode and daybed stated:

This bedroom cabinet was an important piece of furniture in the Lincoln Home.

This was used as a couch during the day and a baby bed at night in the Lincoln Home.

Lucy Rhea, a Springfield antiques dealer, acquired these items from Mrs. Kavanaugh. In Mrs. Rhea's correspondence with the Division of Parks and Memorials about the sale of her items (September 7, 1949), she added the information about the commode that it was used by Mrs. Lincoln. At that time, Mrs. Rhea tried to sell a silk quilt and a dress form which were never purchased. State Historian Jay Monaghan believed the quilt to date from the post-Lincoln period and also questioned the dates of the other items. He did not recommend their purchase unless needed to furnish the Home. Several years later (1953), Richard Hagen (Design Consultant, Archaeology & History, the State of Illinois) followed up on the furniture and the Colonial Dames purchased the commode and daybed which they then donated to the Home.

Stylistically, the commode appears correct for the Lincoln period of occupancy in Springfield; however, the date of the daybed is



questionable. The form is characteristic of nineteenth-century captain's daybeds, usually made in China for the export trade, although some captain's daybeds are believed to have been made in Rhode Island. They were not a common domestic furniture form. The style of turning on the legs and the presence of stamped manufacturer's numbers on the side pieces suggests this daybed dates from the latter half of the nineteenth century and is of American manufacture. Although there is still a possibility that this piece of furniture belonged to the Lincolns, in all likelihood, it did not. Even if owned by the Lincolns, it was probably not used as a child's bed.

#### BLANKET CHESTS:

##### Blanket Chest (LIHO 97)

The blanket chest reportedly belonged to Mary Lincoln and was given by the Lincolns to a family servant, Maria Vance, who, according to the story, worked for the Lincolns for eight years. The supporting evidence for this story is very weak. The Vance family sold the chest to Ada Sutton (author of the only accompanying affidavit), from whom it was bought by Mrs. Carl J. Lamb who, in turn, sold it to the Colonial Dames for the Lincoln Home.

The Vance family is listed in the Springfield Directories; however, there is some question as to whether or not Maria worked

for the Lincolns and, if she did, the length of time. According to the census records, a Catherine Gordon worked for the Lincolns in 1850 and, in 1860, an M. Johnson. Mrs. Lincoln does mention a servant named Mary in an 1859 letter and there is a possibility she was referring to Maria Vance, although Mary Johnson seems more likely.

Stylistically, the chest appears to date from the early nineteenth century and is similar to other Kentucky-made chests. It is possible that Mrs. Lincoln might have owned the chest and might have given it away to a servant.

#### BUREAUS:

There are five bureaus (in addition to the Renaissance revival one mentioned on page 122) with histories indicating that they were at one time in the Lincoln Home. Bureaus were among the items listed for sale by the Lincolns in 1861 and, as there were six rooms on the second floor, it is possible that all five were indeed a part of the Lincoln furniture.

#### Bureau (LIHO 60)

The mahogany bureau, containing four drawers, the top drawer overhanging and supported by columns, was sold by Mr. Lincoln to his friend, John Roll, at the time of the Lincolns' sale in 1861,

according to the Roll family history. John Roll's son, J. Lin Roll, signed an affidavit in 1901 stating the origin of the bureau and that he was selling it to Wm. E. Shutt.<sup>92</sup>

#### Bureaus (LIHO 1126 and 1122)

These bureaus, now in the Lincoln Home, came by way of the Figueira family, Springfield residents. Lucinda Figueira was a seamstress and reportedly sewed for Mary Todd. According to the Figueira family, in lieu of paying a sewing bill, Mary Todd gave Lucinda a bureau (LIHO 1122). Margaret B. Sylva, a descendent of Lucinda Figueira, signed a statement December 5, 1970, outlining the bureau's provenance. The bureau passed from Lucinda to her daughter, Elizabeth Figueira Silva, then to Elizabeth's son, Arthur Huitson Sylva [Silva] and his wife Margaret B. Sylva, and finally to the Sylvas' nephew, Robert Dona Furry, who sold it to the National Park Service, October 5, 1973.

The second bureau (LIHO 1126), a mahogany veneered Federal period style chest of drawers, closely resembles the workmanship of a Lexington, Kentucky, cabinetmaker, Robert Wilson. Characteristics of Wilson's work, such as reeded pilasters, a swell front, single paneled ends, and double-banded veneer between case top and top drawer are found on this chest.<sup>93</sup> As Mary Todd was from Lexington, Kentucky, and may have brought the chest with her,

this attribution lends support to the Figueira family history. Mary might, indeed, have given what would have been an outdated old chest to her seamstress. It also does not seem likely that Lucinda (who was born in 1822 on the Island of Madeira) would otherwise have come into possession of what would have been an old-fashioned piece of furniture from Lexington.

According to an affidavit (in the Henkels sale catalogue of the Lincoln Memorial Collection) written July 28, 1886, the Figueira family also sold a bureau on May 26, 1865, which they reportedly had purchased from the Lincoln sale of 1861, to a John C. Barker, who passed the bureau on to Laura Barker Perry who, in turn, sold it to John W. Keyes for the Lincoln Memorial Collection. The empire style mahogany bureau is marked on the back with the name "Mrs. M.M.F. Barker."<sup>94</sup> (This bureau is now LIHO 1122.)

The Stan Henkels catalogue of the sale of the Lincoln Memorial Collection in 1894 contained the following entry for this bureau:

1602. Mahogany Bureau, from the bedroom of Abraham Lincoln.

Purchased by E. Figueira from Mr. & Mrs. Lincoln in 1861. Sold to John C. Barker, May 26, 1865. Purchased for the Collection from the surviving members of John C. Barker's family. Accompanied with Figueira's affidavit as to its genuineness.<sup>95</sup>

The affidavit which accompanied the bureau is signed by Laura Barker's husband, Wm. Perry. Another discrepancy is that E. Figueira was not born until 1857. They probably meant N. Figueira, for Nicholas Figueira (Lucinda's husband) is mentioned in the Perry affidavit. An 1890 newspaper article in the Chicago Tribune (Monday, April 7, 1890, "Highway & Byway: Stories about Lincoln & Family") recounts the same story in relation to this chest that the Figueira family gave for the other chest, i.e., that Mrs. Lincoln had given the bureau to Mrs. Figueira in lieu of paying a dressmaking bill.

A walnut stand (according to the Henkels catalogue used as a washstand) accompanied the bureau from the Figueiras to the Barkers to the Lincoln Memorial Collection but its location is now unknown.

The Figueiras may have attended the Lincoln sale and, in addition to the chest given them, may have purchased two pieces of furniture. However, of the two bureaus, the Federal period style one (LIHO 1126) appears to have a firmer history of ownership.

#### Bureau (Chicago Historical Society)

The Chicago Historical Society also owns a bureau which reportedly came from the Lincoln residence; this bureau also was sold at the 1861 sale. This bureau was purchased in the 1890s by

Charles Gunther (whose collection of Lincolniana is now at the Chicago Historical Society) from Mrs. Elizabeth Ashmead, the wife of William Ward, a neighbor of Mr. Lincoln's and a jeweler in Springfield. Mrs. Ashmead wrote January 31, 1894, to Mr. Gunther:

...my Husband Mr. William Ward, bought the Bureau for me from Mrs. Lincoln at the sale of their household goods before she left for Washington. She told us that Mr. Lincoln had it made for their first housekeeping, when they were first married.

A strange coincidence, and one that endeared the old Bureau to me, was, that it was the receptacle of the flowers that I had the honor of making the decoration of the draperies of the Catafalque in Cleveland, Ohio....<sup>96</sup>

Mrs. Ashmead went on to say that this bureau was exhibited both at the Philadelphia Centennial Exhibition and at the New Orleans World's Fair. She added a postscript saying that Robert Lincoln could also identify it. Both these letters accompanied the chest to the Chicago Historical Society.<sup>97</sup>

#### Bureau (LIHO 102)

The fifth bureau, and the one with the least supporting evidence, is a walnut chest, supposedly purchased from the Lincolns by Hugh Gallagher, an expressman who lived in Springfield and worked for J. Hough's cabinetmaking shop. Gallagher's daughter, Mrs. Annie E. Kavanaugh signed an affidavit in 1926 stating:

This walnut chest was used in Lincoln Home and purchased by Hugh Gallagher at time of removal, 1858.

This affidavit accompanied others that Mrs. Kavanaugh signed for a walnut commode and a wicker daybed. The Lincoln sale was not until 1861; however, there is evidence that the Lincolns did some furnishing in the late 1850s and these items may have been replaced at that time.

Mrs. Kavanaugh sold her Lincoln items in 1926 to a Springfield antiques dealer, Lucy Rhea, who passed them on to her niece, Mrs. F.D. Ide, who sold them to the State of Illinois for the Home.

#### CHILDREN'S FURNITURE:

There are two pieces of furniture with histories of ownership by Lincoln's children.

#### Child's Chair (LIHO 35)

A small child's chair was donated to the State in 1943 by John Black and Mrs. George Stericker. According to the catalogue card made up at that time, the chair was once used by Tad Lincoln. The file on this chair is incomplete; the original correspondence concerning the transfer appears to be missing. Therefore, there is no supporting documentation for this chair beyond the fact that it was donated by a Springfield family.

Child's Table (LIHO 75)

A child's table was purchased by the Illinois State Department of Conservation in 1970 from Mrs. C. R. Zieke. The previous year, Mrs. Zieke had written to the State Historical Society recounting the family tradition associated with the table. She wrote:

This table has been in my family for many years. It is my understanding that the table was given to my great-grandmother in Springfield, who lived across the street from a caretaker at the Lincoln Home.

There is an old piece of paper pasted on the bottom of the table which says, "Table used by Mr. Lincoln's children as a play table. Martin Ehman, a cabinetmaker, made Mr. Lincoln a wardrobe, and this little table was given him in a broken condition. He repaired it and gave it to his niece, Louise F. Wall, 813 N. 8th St." It may have been this niece who gave it to my great-grand-mother.

Martin Ehmann is listed in the 1860-1861 Springfield City Directory as a carpenter and the Wall family is also listed. As confirmation of her story, Mrs. Zieke also sent with her correspondence a copy of a safekeeping receipt from the Lincoln Centennial Association (dated Feb. 12, 1924). The receipt stated that Mrs. Robert Wall of 813 N. 8th Street had loaned them "1 small table used by Lincoln children -- Lincoln Home."

The available evidence, the receipt, the verifications of names and dates, confirm the Zieke-Wall family history of the table.



## Cradle

A cradle, now on exhibit at Ford's Theater, Washington, D.C. as part of the Oldroyd Lincoln Memorial Collection, appears to have come from the Lincoln home. Charles H. Coe in the 1896 Descriptive and Historical Catalogue of the Oldroyd Lincoln Memorial Collection wrote of the cradle:

Family cradle or crib; black walnut with rockers, length 4 ft., width 3 ft. 6 in., height 3 ft. When Mr. Lincoln was preparing to move to Washington, in 1861, this piece of furniture with several others was stored over John Williams' druggist's store, Springfield, Illinois. As Mr. Lincoln passed through the store, he remarked: "Colonel, the first clerk in your store who needs this article you can present it to him, with my compliments." A year later, one of the clerks, (George Davis), became the happy possessor of the cradle. Afterward sold to S. M. Whitcraft, of Springfield, and by him presented to this collection.

The Lincolns did indeed leave furnishings above Williams' store. From the White House, Mary Lincoln wrote to a friend in Springfield about her furniture:

I see by the papers that Mr. Burch is married. We have some pieces of furniture, still remaining at his house, may I ask a favor of you--It is this--If Mr. Black [George N. Black of John S. Williams Company] can have room for them, can they be moved to any place above his store, where he may have room for them. The sofa, at Mr. Burch's was new, a few months before we left. May I also ask you to speak to Mr. Black, and see if the 8 boxes we left with him, are all there....

DESKS:

Mahogany Lap Desk (LIHO 308)

The mahogany lap desk, now in Mr. Lincoln's bedroom, is well documented, having passed down in the family of Stephen T. Logan, who purchased it from Lincoln. Logan's great-granddaughter, Mrs. Roy W. Ide, Jr., sold it to the Illinois State Division of Parks and Memorials in 1953. In a letter written to Richard Hagen, December 27, 1953, she stated:

The legend that I have been told is that my great-grandfather, Stephen T. Logan, purchased it from Mr. Lincoln. I was told that Lincoln carried it in his saddle bag when he rode the circuit. However, as I wrote you previously, I have nothing to authenticate the case.

MIRRORS:

Shaving Mirrors

Three shaving mirrors have a history of having belonged to Mr. Lincoln.

One, now in the Lincoln Home (LIHO 69), was a gift in the 1920s from Logan Hay who purchased it from Annie Kavanaugh, daughter of Hugh Gallagher, an expressman who worked for J. Hough's cabinet shop, where Lincoln purportedly purchased furniture.

The other two shaving mirrors are in the collection of the Illinois State Historical Society. One was from a collection of

Lincolniana owned by Oliver R. Barrett of Chicago. Twelve items, including this mirror, were loaned to the State Historical Library from 1924-1927 by Mr. Barrett. (See Appendix VII for a list of those items.)

The other mirror in the State Historical Society collections descended in the family of Rita de Silva, along with a sewing table. Rita reportedly was a seamstress for Mrs. Lincoln. The mirror was sold to the State by a de Silva descendent, Edward A. Freitas, on June 29, 1923.

#### WARDROBES:

##### Wardrobe (LIHO 58)

Abraham Lincoln listed "Wardrobes" in his 1861 newspaper advertisement for the sale of his furnishings. Evidence shows the existence of at least two Lincoln family wardrobes.

The one with the firmest Lincoln provenance is the wardrobe purchased at the 1861 sale by Dr. Samuel Melvin, a friend and neighbor of Mr. Lincoln. The wardrobe (LIHO 58) and a whatnot, also purchased at the sale, were handed down in the Melvin family until they were given to the Lincoln Home by two of Dr. Melvin's grandsons. Dr. Melvin's original bill of sale is among the published Lincoln letters. (See p. 45.)

Wardrobe (LIHO 1124)

A second wardrobe, now in the Lincoln Home Collection, also has a strong Lincoln provenance, because it was once a part of the Lincoln Memorial Collection. The wardrobe (along with several other items which were sold to the Lincoln Memorial Collection) was bought from the Lincolns at the 1861 sale by their neighbors, Mr. and Mrs. Allen Miller. The 1896 Henkels auction catalogue of the sale of the Lincoln Memorial Collection had the following entry for this wardrobe:

1612 Walnut Double-Door Cupboard, from Abraham Lincoln's house.

Purchased from Mr. and Mrs. Lincoln by Allen Miller, in February 1861, and accompanied with affidavit as to its genuineness.<sup>100</sup>

An 1890 article in the Chicago Tribune about the Lincoln Memorial Collection ("Highway & Byway: Stories about Lincoln & Family," Monday, April 17, 1890) confused this cupboard with a now unlocated kitchen cupboard or pie safe, referred to on p. 110.

WASHSTAND, TOILET SET, QUILT, PICTURE, AND MISCELLANEOUS ITEMS:  
(Present locations unknown; Miscellaneous items are located in the Collection of Lincoln College, Lincoln, Illinois)

A washstand, a white toilet set, quilt, and a picture (of a church and yard), all supposedly from the maid's room at the Lincoln home, along with twenty-four other items, are mentioned in a 1962 affidavit signed by Robert Watson Kuecher, grandson of

John B. Kuecher, a friend of Lincoln's and a Springfield resident.  
(See Appendix IV.)

In 1962, Morton Barker wrote Richard Hagen, historian for the Department of Conservation, the State of Illinois, concerning these items owned by Emily Barker. On August 7, 1962, Mr. Hagen stated:

My regret is that I was unable to do more in the way of authenticating the Kuecher materials, instead of turning up information that would simply nullify part of the story.

The information which Hagen found has not yet been located. There is in the Lincoln Home file, however, an affidavit written in 1948 by Julius Kuecher, son of John Kuecher, giving certain Lincoln items to his nephew, Robert Watson Kuecher. It reads:

Julius Kuecher, being first duly sworn, on oath states, that the following articles, of great historic value have been given by me to my nephew, Robert Watson Kuecher, and are now in the possession of the said Robert Watson Kuecher:

One hat and hat box, purchased for Abraham Lincoln, at Wolfe's hat store on the West side of the Square in Springfield, Illinois.

One boot jack owned by Abraham Lincoln.

One Chair from Lincoln's Home in Springfield, Ill.

One English plate given to Elizabeth Kuecher, by Mary Todd Lincoln.

One ballot box used in the Presidential election of 1860, in which Lincoln and Douglas were the opposing candidates, which ballot box was presided over by John Kuecher.

One wine-corker to be used in bottling wine, given by Abraham Lincoln, to John Kuecher.

This affidavit is made for the purpose of authenticating the genuineness of these above articles.

Julius Frederick Kuecher (signed)

Subscribed and sworn to before me this 1st day of October A.D. 1948.

John P. Snigg (signed)  
Notary Public

None of the above mentioned items are listed in the Robert Watson Kuecher affidavit (with the possible exception of the chair).

Another letter written by the wife of a John B. Kuecher descendant, Mrs. John Kuecher, to Richard Hagen February 8, 1955, primarily concerning chairs which had come from the Lincoln law office, states that Robert Watson Kuecher owned one of the law office chairs, but does not mention any other Lincoln items owned by Robert.

The present location of the majority of the Lincoln items owned by Robert Watson Kuecher is unknown. He gave a desk and chair (with a history of having come from the law office) to an actor

friend, Pat O'Brien, in 1942. Note that Kuecher in his affidavit mentions only a desk in his sister's home.

Several items were sold to John Valentine, then to King Hostick, from whom Lincoln College in 1957 acquired a china pen wiper, metal lantern, English china plate, and a carving set (marked J. A. Henckel's Works, Solingen, Germany). The lantern is mentioned in the 1962 R.W. Kuecher affidavit.

Although there does seem to be an absence of confirming information for Robert Watson Kuecher's affidavit, it should not be entirely disregarded. The affidavit provides the only available hint as to the contents of the maid's room. Robert Watson Kuecher lists a "white toilet set" which probably refers to an ironstone chamber set and there is archeological evidence of the use of white ironstone at the home during the Lincoln residence.

#### VANITY:

Vanity (Illinois State Historical Society, L.R. 172)

The Illinois State Historical Society also owns a small mirror on stand (a vanity) which belonged to Mary Lincoln. It was willed to the Library in 1954 by Minnie Smith Johnson, Mrs. Lincoln's niece. The vanity was reportedly given to Minnie's mother, Mrs. C.M. Smith by her sister, Mary Todd Lincoln.

DRUGS AND TOILETRIES:

The following items are drugs and toiletries purchased by Lincoln, from Corneau & Diller, Springfield, Ill., 1855-1860, which might have been found in the bedrooms, in and on bureaus.<sup>102</sup>

<u>1855</u>			
Feb. 15	Castor Oil	.10	
	Calomel	<u>.10</u>	.20
Mar. 3	Pearl Powder	.25	
	Woods Restorative	<u>1.00</u>	1.25
Mar. 7	Bottle Lubins Extract		.75
June 29	Bottle Vermifuge		.25
July 3	Castor Oil		.15
Sept. 1	Box Pills		.25
Sept. 15	Box Lubins Extract	.75	
	Box Ox Marrow	<u>.40</u>	1.15
Oct. 4	3 Sticks Cough Candy		.25
Oct. 31	Bottle Liniment		.20
<u>1856</u>			
Oct. 11	Dose Pills		.15
<u>1857</u>			
Oct. 8	Bottle Carminative		.25
Oct. 26	1 oz. Syrup Ipecac		.15
Nov. 2	1 oz. Syrup Ipecac		.15





1860

May 30	Bottle Allen's Restorative	1.50	
	2 Bottles Hair Balsam	<u>.80</u>	2.30
Oct. 12	Woods Restorative	1.00	
	Lubins Extract	1.00	
	Cocaine	.50	
	Box Powder	.15	
	(?)	<u>.25</u>	2.90
Nov. 10	Box Allen's Restorative	1.00	
	Bottle Hair Balsam	<u>.40</u>	<u>1.40</u>
			\$40.95

FABRIC PURCHASES

(Only those which may have been intended as draperies or bedding are included. See also pp. 98 and 118.)

Fabric purchases made by the Lincolns in Springfield from John Williams & Co.:<sup>103</sup>

Mar. 31, 1857	5 yds. Drilling @ .12½	\$ .63
	13½ yds. Muslin @ .10	\$ 1.35
Apr. 16, 1857	16 lbs. Batting @ .18 ¾,	\$ 3.00
	Per Lady	
	10½ yds. French Chintz,	\$ 3.00
	Per Lady	
May 19, 1857	36 yds. Buff Linen @ .25	\$ 9.00
May 20, 1857	Linen Returned	
May 20, 1857	36 yds. Cotton Damask @	\$10.00
	.30, Per Lady	

Two scraps of fabric in the Oldroyd Collection, Ford's Theatre, Washington, D. C., are reportedly from the Lincoln home. One is

a piece of gold and white cotton with a fruit and leaf design woven in white, possibly a piece of Marseilles quilt (FOTH 3485). The other is a printed cotton chintz (FOTH 3482). Both of these scraps correspond to purchases made by the Lincolns. According to their catalogue cards, both scraps were from bedspreads. The catalogue card also notes that these scraps were given to the Oldroyd Collection by a Mrs. Denkle of Springfield who acquired them from Mrs. Lincoln. Although this provenance cannot be confirmed, it is likely that these fabric scraps were from the Lincoln home.

#### FLOOR COVERINGS

The Leslie's Illustrated drawings of the sitting room and front and back parlors show wall-to-wall floral carpeting and hearth rugs in each room. The Lincolns' store accounts in Springfield show only one carpet-related purchase: On April 12, 1851, Mrs. Lincoln bought one piece of carpet binding for \$.31.<sup>104</sup> A letter from Lincoln to the J.C. Louderman Company, however, reveals that the Lincolns purchased carpeting in St. Louis on at least one occasion and may have purchased all their carpeting in St. Louis. St. Louis, a larger, older city than Springfield, had a greater variety of carpets as well as a more fashionable selection. Several St. Louis establishments frequently placed advertisements in

the Springfield papers to draw mail order customers, such as Mr. Lincoln. Mr. Lincoln wrote:

Springfield, Illinois  
March 14, 1852

Gentlemen:

Mr. Binn has returned to Springfield, saying he took the sample of our carpet to you, and afterwards forgot to give the matter further attention. He also says he handed you your own letter to us, with a memorandum of mine at the bottom of it. I must now ask the favor of you to send us back the sample, (as, to lose it, will spoil the carpet we have) and with it, if it matches the quantity, or number of yards (35, I believe) of the new, mentioned in the memorandum. The expense, at all events, and the price of the new carpet, if it matches and you send it, I will pay promptly to your order - and shall feel under <sup>105</sup> great obligation besides. Very respectfully.

A. Lincoln

Strip carpeting at mid-century was usually 27 inches wide; therefore, 35 yards would be enough for one room of a size approximately 240 square feet.

The rear parlor measures 232 square feet, so the carpet may have been intended to match the carpet in the front parlor.

When the Lincolns moved to Washington in 1861, one of the household items they advertised for sale was carpeting. S.H. Melvin, according to his bill of sale signed by A. Lincoln, bought 9½

yards of stair carpet at the Lincoln auction. (See p. 45 for complete bill of sale.) Another purchaser at the auction was Allen Miller who bought a "plush" hearth rug from the Lincolns. This hearth rug eventually became a part of the Lincoln Memorial Collection, but its location is now unknown.<sup>106</sup>

#### WALLPAPER

The following is a list of the Lincolns' known wallpaper purchases from several Springfield stores.<sup>107</sup> These purchases show that major papering took place at approximately four-year intervals with patching occurring in between.

##### John Williams & Co.

Apr. 24, 1851	34 Pieces Wallpaper @ .45	\$15.30
	6 Pieces Border @ .50	\$ 3.00

##### Irwin Journal

Jan. 1, 1852	2 Pieces of Border	
--------------	--------------------	--

##### John Williams & Co.

Mar. 7, 1853	1 Piece Velvet Paper Border	\$ 1.50
Mar. 8, 1853	1 Piece Velvet Paper Border Returned	\$ 1.50
Mar. 15, 1853	1 Piece Wallpaper	\$ .45

July 6, 1855	12 Pieces Wallpaper @ .40	\$ 4.00
	14 Pieces Wallpaper @ .40	\$ 5.60
	4 Pieces Wallpaper @ .37½	\$ 1.50
	6 Pieces Border @ .75	\$ 4.50
	2 Pieces Border @ .25	\$ .50
	4 Pieces Wallpaper @ .37	\$ 1.50
May 10, 1856	5 Pieces Wallpaper @ .37½	\$ 1.88
	6 Pieces Wallpaper @ .37½	\$ 2.25
	2 Pieces Border @ .50	\$ 1.00
	2 Pieces Wallpaper @ .37½	\$ .75
Aug. 5, 1859	Lincoln wrote a \$92.66 check to "Ruckel & Johns," dealers in wallpaper, paint and glass. <sup>108</sup>	

Wallpaper in the parlors and sitting room may be seen in the 1861 drawings from Leslie's, but the patterns are indistinct. Patterns in the dining room and back parlor are more clear in the 1865 stereoscope views.<sup>109</sup> A 1912 photograph of Mr. Lincoln's bedroom (from the Robert Ide Collection, Illinois State Historical Library) is the earliest view of what is believed to be the original wallpaper in Lincoln's bedroom, a piece of which remains on the wall today.<sup>110</sup> In this view, the original paper is partially covered by a dado and border.

The 1861 drawings show the general appearance of the papers for the parlors and sitting room. They are not detailed enough to provide the design for reproductions. They show enough of the overall pattern, however, that a period paper with the same design characteristics could be located and reproduced.

The stereoscope views of the Lincoln back parlor and the dining room were taken after Lincoln's death in 1865. At that time, the Tiltons were renting the Lincoln home. Both views clearly indicate the wallpaper patterns. It is possible that the wallpaper shown in these views was put on the walls by the Lincolns.

Two early references to the wallpaper in Lincoln's bedroom confirm it as original to the Lincoln home. An article on Lincoln's home in The National Picket (July 1891) by Lida Oldroyd describes this paper, "On the wall of this room [Lincoln's bedroom] is the original paper, and very peculiar looking paper it is; it would be difficult to describe, and the name I should apply would be Dolly Varden, the figures are so large and the colors so gaudy."<sup>111</sup>

The Souvenir Supplement of the Illinois State Journal for 1892 stated that two rooms were "papered just as the Lincoln family left them..."<sup>112</sup> There is nothing about the design of the paper to contradict these statements.

FOOTNOTES TO SECTION D

1. Charles Carleton Coffin account, May, 1860, in the Boston Journal quoted in Paul Angle, ed., The Lincoln Reader, pp. 278-280.

2. Springfield Republican, May 23, 1860, quoted in Bearss, Historic Structure Report, p. 22.

3. New York Evening Post, May 23, 1860, quoted in Scott, "Lincoln's Home in 1860," p. 8.

4. New York Commercial Advertiser, May 25; the New York Evening Post, May 26; and the New York Sun, May 30, and June 9, 1860, quoted in Bearss, Historic Structure Report, p. 23.

5. "An Evening with Lincoln," the New York Semi-Weekly of July 6, 1860, quoted in Lincoln Lore, No. 845, Fort Wayne, Indiana, June 18, 1945.

6. New York Herald, June 26, 1860, quoted in Bearss, Historic Structure Report, p. 25.

7. New York Herald, August 13, 1860, quoted in Bearss, Historic Structure Report, pp. 26-27.

8. Frank Leslie's Illustrated Newspaper, November 17, 1860 quoted in Bearss, Historic Structure Report, pp. 27-28.

9. Frank Leslie's Illustrated Weekly, March 9, 1861, quoted in Bearss, Historic Structure Report, p. 28.

10. Chicago Tribune, May 6, 1865, quoted in Bearss, Historic Structure Report, p. 31.



11. Unidentified newspaper article, February 18, 1867, quoted in Kenneth Scott, "Lincoln's Home in 1860," Journal of the Illinois State Historical Society, XLVI, month/year no. 1, p. 12.

12. J. S. Bliss to W. H. Herndon, January 29, 1867, Herndon-Weik Collection.

13. Koerner, Memoirs, II, pp. 93-95.

14. Angle, ed., Abraham Lincoln by Some Men Who Knew Him, "Recollections of Judge Franklin Blades," p. 121.

15. Chicago Tribune, May 6, 1865, quoted Bearss, Historic Structure Report.

16. Ibid.

17. J. S. Bliss to William Herndon, January 29, 1867, Herndon-Weik Collection, Library of Congress, Washington, D.C.

18. Ibid.

19. Ibid.

20. Ibid.

21. Ibid.

22. Ibid.

23. By editorial correspondent of The Utica Morning Herald, letter dated Springfield, Illinois, June 21, 1860, and reprinted in The New York Semi-Weekly of July 6, 1860, under caption "An Evening with Lincoln."

24. Ibid.
25. Ibid.
26. Chicago Tribune, May 6, 1865.
27. New York Evening Post, May 23, 1860, quoted in Kenneth Scott "Lincoln's Home in 1860," The Journal of the Illinois State Historical Society, XLVI, no. 1 (Spring, 1953), pp. 7-12.
28. Memoirs of Gustave Koerner, 1809-1896, II (Cedar Rapids: The Torch Press, 1909), pp. 93-95.
29. Ibid.
30. Charles Carleton Coffin, account, May, 1860, in the Boston Journal quoted in Paul Angle, ed., The Lincoln Reader, pp. 278-280.
31. Ibid.
32. Chicago Tribune, May 6, 1865.
33. Ibid.; See also Paul M. Angle, ed., Abraham Lincoln by Some Men Who Knew Him, "Recollections of Judge Franklin Blades," p. 121.
34. Frank Leslie's Illustrated Newspaper, November 17, 1860, quoted in Bearss, Historic Structure Report, pp. 27-28.
35. Advertisement for Public Sale, Illinois State Journal, January 29, 1861.

36. Melvin bill of sale, Journal of the Illinois State Historical Society, (JISHS) XLIV, no. 1 (Spring, 1961), pp. 61-63.

37. See Bearss, Historic Structure Report, plates II, III, IV, V, VI.

38. William Waud ( ? -1878) was a noted illustrator for Leslie's Illustrated Weekly and Harpers Weekly during the Civil War.

39. Rufus Wilson, What Lincoln Read (Washington, D.C., 1932), p. 59.

40. Turner, Mary Todd Lincoln, p. 67.

41. Katherine Helm, Mary, Wife of Lincoln (New York: Harper Brothers, 1928), p. 134.

42. The original papers, affidavits, etc. are located at the Historical Society of Pennsylvania, Harrisburg, Pennsylvania. Copies may be found at the Illinois State Historical Society Library.

43. Stan V. Henkels, Catalogue No. 731: The Valuable Collection of Autographs and Historical Papers Collected by The Hon. James T. Mitchell also The Entire Lincoln Memorial Collection of Chicago, Illinois (Philadelphia, 1894).

44. Ellen Kirven Donald, Furniture from the Collection of the Lincoln Home National Historic Site (Harpers Ferry Center, National Park Service, Harpers Ferry, West Virginia, June, 1978), Items 3-8.

45. Melvin bill of sale, JISHS, pp. 61-63.

46. Robert Bishop, Centuries and Styles of The American Chair 1640-1970 (New York: E. P. Dutton & Co., Inc., 1972), pp. 390-391. A set of chairs in the style of LIHO 28 (a Cottage style, factory-made, cane-seated chair, which has a Lincoln history) is another alternative for dining room chairs. However, they have not been recommended because the evidence of Lincoln provenance is not as strong as the Oldroyd's documentation for the fancy chair. There is also a possibility that chairs in the style of chair No. 28 were not available at the time the Lincolns lived in Springfield. These chairs were factory made, inexpensive and very popular during the 1870s. The earliest suggested date for this style is 1865. Although dating according to style is not conclusive, until further evidence becomes available, these chairs should not be exhibited in the Lincoln Home.

47. See Bearss, Historic Structure Report, plate VIII.

48. Charles H. Coe, A Descriptive and Historical Catalogue of the Oldroyd Lincoln Memorial Collection (1896) from the collection of the Lincoln Museum, Ford's Theater, National Historic Site, National Park Service, Washington, D.C.

49. "An Interview with Oldroyd," quoted in file on Lincoln furniture from The Lincoln Home files, The Illinois State Historical Society Library, Springfield, Illinois.

50. Dana J. Blackwell, Chief Engineer, Clock Division, Howard Clock Products, Inc., to Chester V. Hamilton, Acting Superintendent, Lincoln Home, National Historical Society, August 18, 1975, Accession File No. 1, LIHO.

51. E. Howard and Co., Illustrated Catalogue of Clocks (Boston, 1874), nos. 11-14.

52. "Chairs Used by the Lincolns," Lincoln Lore (no. 1318), July 12, 1954.

53. William Waud Collection, Division of Prints and Photographs, The Library of Congress, Washington, D. C.

54. A girandole is an ornamental branched candleholder, usually in sets, with marble bases, used as mantel garniture. See Ethel Doane, Antiques Dictionary (Portland, Maine: 1949); Donald Cowie, Antique Collector's Dictionary (N. Y.: Arco Press, 1963); and Webster's Third New International Dictionary of the English Language Unabridged (1976).

55. The affidavit was not located at the time of this report although it is mentioned in a letter written by the appraiser of artifacts, Frances S. Ridgely, found in Accession File No. 1.

56. See Bearss, Historic Structure Report, plate II.

57. Mary Lincoln to Julia Ann Sprigg, May 29, 1862, in Justin G. Turner and Linda Levitt Turner, Mary Todd: Her Life and Letters (New York: Alfred A. Knopf, 1972), pp. 127-128.

58. Coe, Descriptive Catalogue, sofa no. 2.

59. Ibid., sofa, no. 3.

60. Mary Lincoln to Julia Ann Sprigg May 29, 1862, in Turner, Mary Todd, pp. 127-128.

61. A "couch" at mid-century referred to an elaborate daybed or lounge.

62. Henkels, Catalogue No. 731, no. 1592.

63. J. M. Forden affidavit, Lincoln Memorial Collection, The Historical Society of Pennsylvania.

64. See Accession No. 23, list of shards by Ruthanne Heriot, and Richard Hagen, "Backyard Archeology," Journal of the Illinois State Historical Society, LIV, no. 4 (Winter, 1951).

65. The origin of this soap dish was not noted on the catalogue card and no information was found in the accession file. However, a letter from Richard Hagen in the Lincoln Home file, Illinois State Historical Society Library, dated July 1, 1953 to a donor of tea leaf china, Mrs. Naomi Koelling, says that the mark on her china, Alfred Meakin, England, with shield, is identical to a mark on china dug up in the Lincoln backyard. According to James Hickey, Richard Hagen was aware that the tea leaf ironstone was not from the 1850s. He accepted it because of the enthusiasm of the organization that was donating it.

66. Geoffry A. Godden, Encyclopedia of British Pottery and Porcelain Marks (New York: Crown Publishers, 1964), p. 425.

67. Photo of toothbrush taken in 1951, excavated from backyard, Lincoln Home Files, Illinois State Historical Society Library.

68. See Accession No. 23, list of shards by Ruthanne Heriot, and Richard Hagen, "Backyard Archeology," JISHS.

69. This information was compiled from the accession files at the Chicago Historical Society, Clark Street at North Avenue, Chicago, Illinois 60614.

70. "Lincoln Heirlooms Found in Capital," Chicago Daily News, Tuesday, June 30, 1953.

71. Accession File No. 1921.7, Chicago Historical Society, Chicago, Illinois.

72. Harry E. Pratt, The Personal Finances of Abraham Lincoln, Springfield, Illinois (The Abraham Lincoln Association, 1943), pp. 145-159.

73. Zane, "Lincoln As I Knew Him," JISHS.

74. Godden, Encyclopedia of Pottery, p. 150.
75. Robert Todd Lincoln to Samuel Willard, March 22, 1909, Chicago Historical Society, quoted in Ruth Painter Randall, Mary Lincoln: Biography of a Marriage (Boston: Little, Brown, & Co., 1953), p. 107.
76. Accession File no. 1927.2, Chicago Historical Society, Chicago, Illinois.
77. Ibid., Accession no. 1920/683, a. b.
78. Dr. Lattimer to Ms. Mary Ellen McElligott, October 16, 1973, Lincoln Home file, Illinois State Historical Society Library.
79. Interview with James Hickey, Curator of Lincoln Artifacts, Illinois State Historical Society Library, March 12, 1979. According to Mr. Hickey, Margaret Sinninger was a very good friend of Robert Lincoln.
80. Coe, Descriptive Catalogue, No. 9.
81. According to James Hickey, there is a cupboard in the Old State Capitol in Springfield that came from William Herndon. It probably was in the Lincoln-Herndon law office but could have been in the Lincoln home first.
82. According to the Lincoln scholar James Hickey, there is some doubt as to whether or not Maria Vance was a cook in the the Lincoln household (James Hickey Interview, May 12, 1979).
83. Pratt, Personal Finances, pp. 145-159.

84. William E. Baringer, Lincoln Day by Day: A Chronology 1809-1865 (Washington, D. C., Lincoln Sesqui-centennial Commission, 1960).
85. Bearss, Historic Structure Report, plates IV, V, and VI.
86. Waud Collection, Library of Congress.
87. Bearss, Historic Structure Report, pp. 39 and 105.
88. Pratt, Personal Finances, p. 92.
89. The information on Bishop Seymour and the Cantrells was compiled by Dr. Wayne Temple, Illinois State Archives, Springfield, Illinois.
90. Mrs. Seymour to Mr. Graham, undated, owned by the Evans Cantrell family, 1020 Bismarck Way, Oxnard, California.
91. Memo by Virginia Stuart Brown, March 5, 1951, Lincoln Home files, Illinois State Historical Society Library.
92. Lincoln Home files, Illinois State Historical Society Library.
93. Mary Clay McClinton, "Robert Wilson, Kentucky Cabinetmaker," Antiques Magazine (May 1973), pp. 945-949.
94. Lincoln Memorial Collection. Original papers located at the Historical Society of Pennsylvania.



95. Henkels, Catalogue No. 731, no. 1602.

96. Mrs. Elizabeth Ashmead to C. F. Gunther, 1894, Accession File no. XA-96, Chicago Historical Society.

97. Ibid.

98. Coe, Descriptive Catalogue, Cradle. According to James Hickey, Robert Todd Lincoln did not believe this cradle was the family cradle. According to Robert Lincoln, the cradle was disposed of when the boys were small. Robert's recollections are, however, somewhat effected by his dislike of Oldroyd and Oldroyd's care of the house.

99. Mary Lincoln to Julia Ann Sprigg, May 29, 1862, in Turner, Mary Todd Lincoln, pp. 127-128.

100. Henkels, Catalogue No. 731, no. 1612.

101. These artifacts are in the Collection of Lincoln College, Lincoln, Illinois, along with other artifacts which have a history of having come from the Lincoln home through the Kuecher family; see Appendix IV.

102. The following information was taken from Pratt, Personal Finances, pp. 145-159.

103. Ibid.

104. Ibid.

105. Roy P. Basler, The Collected Works of Abraham Lincoln (New Jersey: Rutgers University Press, 1953), II, p. 120.

106. See Miller affidavit by Lafayette Smith, April 10, 1886, Lincoln Memorial Collection Papers, Historical Society of Pennsylvania.
107. Pratt, Personal Finances, pp. 145-159.
108. Baringer, Lincoln Day By Day, p. 257.
109. Bearss, Historic Structure Report, plates II and III.
110. Ibid., plate XII.
111. Lida Oldroyd, in The National Picket, I, no. 1 (1891), pp. 7-8.
112. "Springfield in 1892:Souvenir Supplement," Illinois State Historical Society Journal (Springfield, 1892) quoted in Bearss, Historic Structure Report, p. 51.

## THE PLAN

### SECTION E: RECOMMENDED FURNISHINGS

Both the Leslie's Illustrated drawings and the surviving original Lincoln furniture show the Lincoln Home furnishings to be excellent examples of solid middle-class household goods at mid-century. Caroline Owsley Brown, in "Springfield Society Before the Civil War," described the furnishings of the more fashionable houses in Springfield:

Many of the houses were furnished very handsomely, with velvet carpets, damask and lace curtains with silk brocatelle, and the tables boasted gold banded china and solid silver and almost everyone kept their own carriage.

The Lincoln house was furnished similarly but with slightly less expensive items. For example, Mrs. Lincoln purchased cotton damask for draperies rather than silk and the parlor furniture was mahogany and walnut rather than the more expensive rosewood.

The Lincoln furnishings in Springfield were not the most up-to-date styles; however, they were reflective of the major decorative trends at that time. The house contained a variety of late Empire style, Gothic, Rococo Revival, and Cottage style furniture. Some furniture appears to have been locally made while other furniture is characteristic of the early factory furniture exported from the east and larger urban centers, such as Cincin-

nati and St. Louis. For example, J. A. Hough advertised in the Illinois Daily Journal, May 11, 1849:

Cabinet Warehouse--Cabinet Furniture, Chairs, Looking-Glass Plates, Mattresses, Willow Wagons, Clocks, etc., etc. of<sup>2</sup> New York, Boston, and Cincinnati Manufacture.

Although Lincoln was able to purchase eastern furniture in Springfield, the selection would have been better in St. Louis or Cincinnati. Lincoln purchased carpeting in St. Louis and it is logical to assume he purchased other furnishings there as well. Indeed, according to advertisements by Springfield cabinetmakers, St. Louis cabinetmaking establishments were considered competition. For example, an advertisement by J. Hutchinson, January 2, 1850, in the Springfield Illinois Daily Journal read:

The extensive Warerooms of the establishment will always be supplied with a large stock of FURNITURE, consisting in part of Sofas, Secretaries, Bookcases, Centre and side Tables, Work and Card Tables, Sideboards, Dressing Bureaus, Common Bureaus, Cupboards, Wardrobes, Presses, High-Post, French and Common Bedsteads, Lounges, Washstands, Chairs, Cribs, and Cradles, &c. &c. &c: and in order that the public may have a full and fair opportunity of judging for themselves, between our own manufactured articles and those from abroad, we further invite their attention to the following articles, just received from the eastern markets, viz:

Mahogany Centre Tables	Plain and Tufted Sofas
Cherry Card do.	Fancy Divans
Dressing Bureaus,	Mahogany Wash Stands,
Common do.	Plain do.
Mahogany Toilet Stands,	O.G. Pillar Card Tables,
Common do.	Rocking Chairs, &c. &c.

The patronage of the public generally is respectfully solicited, and all who visit this very extensive establishment will be made satisfied that it richly merits the confidence and support of an intelligent and judicious community, who appreciate the importance of encouraging Home Manufactures, and building up our own region of country, instead of furnishing our means to add to the wealth of St. Louis, Cincinnati, and the eastern cities.  
J. HUTCHINSON.<sup>3</sup>

Another advertisement in 1857 showed that J. Hutchinson was still concerned with the competition from St. Louis. It read:

I have also made arrangements for a constant supply of Eastern work....Persons wishing to fill orders can do so at as reasonable terms as St. Louis or any other western city.

Thus the Lincoln home would most likely have contained furniture from Springfield and other cities. Locally manufactured furniture was made of native woods and in a variety of styles. In central Illinois, furniture was made of walnut, cherry, ash, and sycamore; and in northwest Illinois of maple, oak, birch, or pine. Betty Madden in Arts, Crafts, and Architecture in Early Illinois (Urbana, Chicago, London: University of Illinois Press, 1974) illustrates numerous examples of this Illinois-made furniture.

Section E of this Furnishing Plan is based on the surviving original Lincoln furnishings and period documentation. Where it has been necessary to fill in additional furniture, items have been

added that correspond to the tastes reflected in the original furnishings. Placement and quantities of furniture are based largely on the Leslie's drawings, other period illustrations, such as paintings and prints, and household guidebooks--in particular Miss Leslie's Lady's House Book (Philadelphia, 1846), a copy of which Mrs. Lincoln owned. Miss Leslie's was a very popular household manual.

Although there do not seem to be many surviving records of the 1952-1955 restoration, refurnishing was comprehensive, and the majority of the furnishings now in the house are of an appropriate date and style for the Lincoln Home. Over the years, however, additional items have been acquired and in almost every room, according to recent research on furnishings, there are too many items. The changes recommended by this report will mean the elimination of many items.

#### PARLORS: INTRODUCTION

The Lincolns' front parlor was used primarily for the family's more formal entertaining. (See pp. 17-25 for accounts of the Lincolns' parties.) If it were a large gathering, both the front and back parlors would have been in use. The front parlor, however, contained the more formal, elegant furniture. In the Leslie's drawing, furniture in both the late Empire and Rococo Re-

vival style can be seen. In the rear parlor, there is little evidence of the more fashionable Rococo Revival style. The sofa, secretary, and chairs reflect the late Empire style, and the side tables are in the Cottage style or "Elizabethan" style.

Contemporary accounts referred to the back parlor as the "Library." A secretary-desk appears in the Leslie's drawing of this room. It is likely that when Lincoln worked at home or entertained business friends he used this room.

FRONT PARLOR: ROOM A

See p. 304, for Summary of Furnishings and Cost Estimates.

Object: Sofa A.1

Date: 1850-1860

Brief Description: Transitional between late Empire and Rococo style, with tufted horsehair upholstery.

Location: South wall

Documentation: Leslie's Illustrated Newspaper March 9, 1861.

The sofa which appears in the drawing is now at the Chicago Historical Society; however, this sofa (LIHO 1060) which also has a Lincoln history, although not as strong as the Chicago one, is similar enough to the drawing to be appropriate. (See pp. 69-71 for a discussion of these sofas.)

Source: LIHO 1060.

FRONT PARLOR: ROOM A

Object: Side Chairs, four (of a set of six) A.2-5

Date: 1850-1860

Brief Description: Four matching side chairs, mahogany, late Empire style, curved crest rail, vase shaped splat, slip seats, horsehair upholstery.

Location: One under each of the windows and one on either side of the whatnot on north wall to the east of the stove.

Documentation: Leslie's Illustrated Newspaper, March 9, 1861; LIHO 1119 through 1124 are well documented surviving pieces of furniture (Lincoln Memorial Collection) originally owned by the Lincolns in Springfield. (See pp. 53-55 for provenance.) Five of the six chairs appear in the Leslie's drawings. It is logical to assume the sixth chair was placed in a location not visible in the drawings.

Source: LIHO 1116, 1117, 1118, 1119.

Object: Rocking Chair A.6

Date: ca. 1840-1860

Brief Description: Upholstered, arm rocker with carved floral motif on crest rail, tufted horsehair upholstery.

Location: Southwest side of fireplace.



FRONT PARLOR: ROOM A

Documentation: Leslie's Illustrated Newspaper, March 9, 1861.

A mahogany, black haircloth rocking chair from the Lincoln home was once part of the Oldroyd Collection. It is now missing. (See p. 59 for complete discussion of provenance.) There are several other rocking chairs with a Lincoln history of ownership; however, their Lincoln provenance is not as strong as the Oldroyd one (see pp. 55-57, 79 through 86).

Source: LIHO 19.

Object: Footstool A.7

Date: ca. 1840-1860

Brief Description: Small footstool on four turned legs, with horsehair upholstery.

Location: Southwest side of fireplace.

Documentation: Leslie's Illustrated Newspaper, March 9, 1861.

Source: LIHO 39.

Object: Rocking Chair A.8

Date: 1840-1860

Brief Description: Identical to the above chair with the exception that the rocker has open arms with horsehair-covered, padded armrests and does not have tufted upholstery.

FRONT PARLOR: ROOM A

Location: Northeast corner of room.

Documentation: Same as above.

Source: To be acquired (antique).

Object: Footstool A.9

Date: 1840-1860

Brief Description: Small footstool with four turned legs, with horsehair upholstery.

Location: Northeast corner of the room.

Documentation: Leslie's Illustrated Newspaper, March 9, 1861.

Source: LIHO 65.

Object: Mirror A.10

Date: 1850-1860

Brief Description: Pier mirror, gilt, with rounded top, some ro-coco decoration on crest, about four feet tall.

Location: Between front windows.

Documentation: Leslie's Illustrated Newspaper, March 9, 1861.

Location of the original is unknown.

Source: To be acquired (antique); LIHO 17, however, can be used until acquired.

FRONT PARLOR: ROOM A

Object: Pier Table A.11  
Date: 1850-1860  
Brief Description: Marble-topped serpentine front table with cabriole legs and lower shelf.  
Location: Between front windows in north front parlor.  
Documentation: Appears in 1861 drawing of parlor in Leslie's Illustrated Newspaper. The original table, LIHO 1114, became part of the Lincoln Memorial Collection and is now at the Lincoln Home. (See pp. 72-73 for complete discussion of provenance.)  
Source: LIHO 1114.

Object: Whatnot A.12  
Date: 1850-1860  
Brief Description: Corner whatnot with five shelves, and machine-cut scroll work decoration.  
Location: Northwest corner.  
Documentation: Appears in March 9, 1861 drawing of parlor in Leslie's Illustrated Newspaper. (See pp. 40-41 for a contemporary reference to "a whatnot in the corner of the room." The present location of the original corner whatnot is unknown, but LIHO 18 is appropriate and should be placed in this room.)  
Source: LIHO 18.

FRONT PARLOR: ROOM A

Object: Whatnot A.13  
Date: 1850-1860  
Brief Description: Five shelves with spool turned supports and machine-cut scrollwork decoration on the back.  
Location: North wall to the east of fireplace.  
Documentation: Leslie's Illustrated Newspaper, March 9, 1861.  
Whatnot, LIHO 24, has a history of Lincoln ownership, although it is not well documented. (See pp. 96-98 for its history. Also, see pp. 40-41 for contemporary written reference to a whatnot in the Lincoln parlor.)  
Source: LIHO 24.

Object: Parlor Stove A.14  
Date: 1855-1860  
Brief Description: Gothic style fancy parlor stove on cabriole legs.  
Location: North parlor fireplace.  
Documentation: Leslie's Illustrated Newspaper, March 9, 1861.  
(See pp. 108-109 discussion of location of original stove.)  
Source: LIHO 174.

FRONT PARLOR: ROOM A

- Object: Stove Implements: Shovel, Tongs, Stand, Hearth Brush A.15
- Date: 1850-1860
- Brief Description: Iron and brass shovel and tongs; wooden hearth brush.
- Location: Stove.
- Documentation: Period sources.
- Source: To be acquired (antique).
- 
- Object: Oval Picture A.16
- Date: ca. 1840-1860
- Brief Description: Floral print in wooden ogee frame (1½'x1') hung with picture cord and tassels; a floral design of wax, shells or flowers, or hair would be equally appropriate.
- Location: North wall, west of fireplace.
- Documentation: Frank Leslie's Illustrated Newspaper, March 9, 1861. Contemporary accounts mention "pictures" (for example, see pp. 35-36).
- Source: LIHO 168.
- 
- Object: Pair of Prints, George and Martha Washington A.17
- Date: ca. 1842-1850

FRONT PARLOR: ROOM A

Brief Description: Prints in oval, gilt frames, with floral decoration at the top, hung from wall, ceiling height, with picture cord and tassels.

Location: Over fireplace.

Documentation: Two small oval pictures of figures are visible in the March 9, 1861 Leslie's Illustrated drawing. The subject matter is not visible.

Source: LIHO 169 and 170.

Object: Three Oval Pictures A.18

Date: ca. 1840-1860

Brief Description: Three pictures of period subject matter in matching oval frames hung from nails, no cord showing.

Location: Over whatnot on north wall.

Documentation: Leslie's Illustrated Newspaper, March 9, 1861.

Center picture appears to have a figure subject.

Source: To be acquired (antique).

Object: Girandole A.19

Date: ca. 1840-1860

Brief Description: Two single-arm candlesticks and one three-branch candlestick with glass prisms.

FRONT PARLOR: ROOM A

Location: On the mantel.

Documentation: Leslie's Illustrated Newspaper, March 9, 1861.

Two sets of girandoles have Lincoln histories of ownership. The set with the strongest Lincoln provenance (from the Herndon family, see pp. 64-65) consists of two single-arm candlesticks and one three-arm candlestick and would be appropriate for this room.

Source: LIHO 150, 151, 152.

Object: Pair of China Pitchers A.20

Date: ca. 1850-1860

Brief Description: Two matching French porcelain pitchers with hand painted decorative scenes.

Location: On the mantel.

Documentation: Leslie's Illustrated Newspaper, March 9, 1861.

French china, popular at mid-century as a mantel garniture, was available in Springfield and in keeping with Mary Lincoln's tastes as later evidenced by her purchases in the White House.

Source: LIHO 148 and 149.

Items to be Located on the Pier Table:

Top

Object: Basket A.21

FRONT PARLOR: ROOM A

Date: ca. 1840-1860

Brief Description: China with flower arrangement.

Object: Vase A.22

Date: ca. 1840-1860

Brief Description: Tall cut glass vase, to the east of the basket.

Object: Decanter A.23

Date: ca. 1840-1860

Brief Description: Glass decanter, in front of glass vase.

Object: Two Small Ornaments A.24

Date: ca. 1840-1860

Brief Description: Glass or china, appear to the west of the basket.

Shelf

Object: Two Glass Decanters A.25

Date: ca. 1840-1860

Brief Description: Pressed or blown three-mold glass.



FRONT PARLOR: ROOM A

Object: Ornament A.26

Date: ca. 1840-1860

Brief Description: China.

Documentation: The above items may be seen in the March 9, 1861, Leslie's Illustrated Newspaper drawing. This sort of arrangement is also characteristic of mid-century garniture. The glassware should be a combination of cut, pressed, and Bohemian glass.

Source: To be acquired (antique).

Corner Whatnot Items, to be Asymmetrically Arranged:

Object: Two Small Decanters A.27

Date: ca. 1840-1860

Brief Description: Two small, blown glass decanters.

Location: Lower shelves.

Documentation: Leslie's Illustrated Newspaper, March 9, 1861, drawing.

Source: LIHO 135, 136.

Object: Three Small Vases A.28

Date: ca. 1840-1860

Brief Description: Three small glass or ceramic vases.

FRONT PARLOR: ROOM A

Location: Lower shelves.

Source: LIHO 153, 696, 697.

Object: Two Bottles with Stoppers A.29

Date: ca. 1840-1860

Brief Description: Two blown glass bottles with stoppers.

Location: Lower shelves.

Documentation: Leslie's Illustrated Newspaper, March 9, 1861 drawing.

Source: To be acquired (antique).

Object: Two Books A.30

Date: ca. 1840-1860

Brief Description: To have ornamental bindings.

Location: Middle shelf.

Documentation: Books appear in the March 9, 1861, Leslie's Illustrated Newspaper drawing of the other whatnot and are typical shelf garniture. (See book list, pp. 48-53, for titles owned by the Lincolns.)

Source: LIHO 936, 938.

FRONT PARLOR: ROOM A

Object: Assortment of Seashells, A.31  
including a Trochus

Location: Lower shelf.

Documentation: A contemporary account by the correspondent, J. S. Bliss (to Herndon, 1866), mentions seashells on corner whatnot, and specifically mentions a trochus (see pp. 40-41 for full account).

Two seashells have a history of having come from the Lincoln home (see pp. 102-103). The tradition associated with them says they were used to hold down the draperies. They do not appear in the drawings and the draperies do not look long enough to fit under the shells. No documentation has been found to suggest this was a popular practice. A more logical use of these shells would be on the bottom shelf of the whatnot, with flowers arranged in them, a popular period practice. Conches, periwinkles, whelks, and scallops are among popular shells found in nineteenth-century collections.

Source: LIHO 285-292.

Object: Two China Ornaments A.32

Date: ca. 1840-1860

Location: Top shelf.

FRONT PARLOR: ROOM A

Documentation: Several indeterminate items appear on the top shelf in the March 9, 1861, Leslie's Illustrated Newspaper drawing and china ornaments would be appropriate.

Source: To be acquired (antique).

Five-Shelf Whatnot:

Top Shelf

Object: Volk Bust of Lincoln A.33

Date: 1860

Brief Description: Small plaster of Paris bust of Lincoln.

Documentation: See p. 100 for discussion of documentation, and see Leslie's Illustrated Newspaper, March 9, 1861 drawing.

Source: LIHO 134. A reproduction bust now located at the Lincoln Home is appropriate.

Object: Four Decanters A.34

Date: ca. 1840-1860

Brief Description: Pressed or blown glass.

Documentation: See Leslie's Illustrated Newspaper, March 9, 1861 drawing.

Source: To be acquired (antique).

FRONT PARLOR: ROOM A

Second Shelf

Object: Two Busts A.35  
Date: ca. 1840-1860  
Brief Description: Parian ware busts and subjects should be figures Lincoln admired.  
Documentation: See Leslie's Illustrated Newspaper, March 9, 1861 drawing.  
Source: LIHO 138, 137.

Third Shelf

Object: Three Books A.36  
Date: ca. 1840-1860  
Brief Description: Three books with ornamental leather bindings.  
Documentation: See Leslie's Illustrated Newspaper, March 9, 1861 drawing and the Lincoln book list pp. 48-53.  
Source: To be acquired (antique).

Object: One Statuette A.37  
Date: ca. 1840-1860  
Brief Description: Parian ware.  
Documentation: See Leslie's Illustrated Newspaper, March 9, 1861 drawing.  
Source: To be acquired (antique).

FRONT PARLOR: ROOM A

Object: Vase A.38  
Date: ca. 1840-1860  
Brief Description: One covered double-handled ceramic vase.  
Documentation: See Leslie's Illustrated Newspaper, March 9, 1861 drawing.  
Source: To be acquired (antique).

Fourth Shelf

Object: Set of Five Books A.39  
Date: ca. 1840-1860  
Brief Description: One set of five books (same size, height, binding) with ornamental bindings.  
Documentation: See Leslie's Illustrated Newspaper, March 9, 1861 drawing and the Lincoln book list on pp. 48-53.  
Source: To be acquired (antique).

Fifth Shelf

Object: Four Books A.40  
Date: ca. 1840-1860  
Brief Description: Oversized, to be stacked vertically, with ornamental bindings.

FRONT PARLOR: ROOM A

Documentation: See Leslie's Illustrated Newspaper, March 9, 1861 drawing and see the Lincoln book list on pp. 48-53.

Source: To be acquired (antique).

Object: Decanter A.41

Date: ca. 1840-1860

Brief Description: Blown or pressed glass.

Documentation: See Leslie's Illustrated Newspaper, March 9, 1861 drawing.

Source: LIHO 161.

REAR PARLOR: ROOM B

See p. 308 for Summary of Furnishings and Cost Estimates.

Object: Side Tables B.1-2

Date: ca. 1850-1860

Brief Description: Elizabethan style, pair of side tables with spool turned supports and lower shelf.

Location: East corners of rear parlor.

Documentation: Leslie's Illustrated Newspaper, March 9, 1861.

Source: LIHO 3 and 4 (reproductions).

Object: Pair of Globes B.3-4

Date: ca. 1850-1860

REAR PARLOR: ROOM B

Brief Description: Celestial and terrestrial globes resting in short turned stands (for use on a table top).

Location: One on each Elizabethan style side table.

Documentation: Leslie's Illustrated Newspaper, March 9, 1861.

A contemporary account from the Boston Journal, May 1860, described "two globes, celestial and terrestrial, in the corners of the room." (See p. 34.)

Source: LIHO 1 and 2.

Object: Side Chairs, two (of a set of six) B.5-6

Date: 1850-1860

Brief Description: Identical to those in the front parlor (see pp. 53-55), horsehair upholstery.

Location: One in front of secretary and one in front of west window. (Five of the six chairs appear in the Leslie's drawings of the front and back parlors. In the back parlor, a side chair is on the west wall, south of the door, and in front of the window near the opening to the front parlor. In the case of the back parlor, however, the visitor traffic flow necessitates a slight rearrangement of the furniture and placement of the chairs in front of the window; the secretary, west of the fireplace, is appropriate.) These chairs, from the Lincoln Memo-



REAR PARLOR: ROOM B

rial Collection, have a well-documented Lincoln history of ownership (see pp. 53-55).

Source: LIHO 1120 and 1121.

Object: Sofa B.7

Date: 1850-1860

Brief Description: Transitional style between late Empire and Rococo, serpentine back, outward framing arms and legs, upholstered with tufted back, in black horsehair.

Location: East wall, between side tables.

Documentation: Leslie's Illustrated Newspaper, March 9, 1861.

Several sofas have a Lincoln history of ownership (see pp. 68-72 and pp. 92-93 for a discussion of their provenance.) LIHO 1059, a sofa from the Oldroyd Collection, now in the Lincoln Home, would be most appropriate in this location.

Source: LIHO 1059.

Object: Secretary-Desk B.8

Date: 1840-1860

Brief Description: Large secretary-desk and bookcase with glass fronted doors, six shelves, fold-out desk top, and paneled doors

REAR PARLOR: ROOM B

enclosing shelves beneath desk, turned front legs and bracket rear legs.

Location: Original location, according to March 9, 1861, Leslie's Illustrated drawing, was against the south wall now opening to front parlor. Visitor traffic prevents this placement; therefore, it should be placed against the south wall, on the other side of the door to the dining room.

Documentation: Leslie's Illustrated Newspaper, March 9, 1861. Several contemporary accounts mention that Lincoln's books were in this room, and two refer to his "bookcase." (See pp. 35, 38.)

Source: LIHO 6.

Object: Table B.9

Date: ca. 1840-1860

Brief Description: Round, mahogany veneered or walnut center table with pedestal base.

Location: In front of fireplace.

Documentation: A contemporary account written by a correspondent of the Boston Journal (May 1860) recorded that there was "a plain table with writing materials upon it, a pitcher of cold water, and glasses..." (see p. 34 for full account) in this room.

REAR PARLOR: ROOM B

No table of this description appears in the Leslie's drawing. In fact, there is no center table in the drawing of any of the downstairs rooms, which is unusual because the center table was a very common form at mid-century. For example, Andrew Jackson Downing, in his popular book on the Architecture of Country Houses, published in 1850, described the center table as "the emblem of the family circle."<sup>5</sup>

It is logical to suppose that either the artist eliminated all furniture from the center of the rooms or the Lincolns removed furniture to accommodate the large numbers of visitors they began to receive after Mr. Lincoln's election.

Source: To be acquired (antique).

Object: Girandole B.10

Date: 1850-1860

Brief Description: Two single-arm candlesticks and one three-branch candlestick, with hanging prisms.

Location: On the mantel.

Documentation: Leslie's Illustrated Newspaper, March 9, 1861.

The girandoles shown in the drawings of the front and back parlor have the same general appearance and were probably similar, if not identical. There are two documented sets of candelabra with

REAR PARLOR: ROOM B

histories of having come from the Lincoln home (see pp. 64-65), although only one of these sets is now in the Lincoln Home Collection.

Source LIHO 378, 379, and 380.

Object: Pair of Pitchers B.11-12

Date: ca. 1850-1860

Brief Description: Porcelain, French (or English) with painted decoration.

Location: On the mantel.

Documentation: Leslie's Illustrated Newspaper, March 9, 1861.

See also discussion under mantel garniture for the front parlor.

Source: To be acquired (antique).

SITTING ROOM: INTRODUCTION

The sitting room served as the Lincoln family's everyday living area. The Leslie's illustration clearly shows that the sitting room contained less formal (and less expensive) furnishings than the parlors. For example, there is very little upholstered furniture in this room. Upholstered furniture, such as sofas and armchairs, were expensive luxuries and, in most families, would

customarily have been reserved for the parlors. And yet, this room, with its pair of rocking chairs, does seem comfortable.

According to period use, the large table, appearing in the Leslie's drawing on the east wall, would have been in the middle of the room. The family's activities, such as reading, playing checkers, and Mrs. Lincoln's sewing, would have taken place around the table and the light source located on the table.

SITTING ROOM: ROOM C

See p. 310 for Summary of Furnishings and Cost Estimates.

Object: Rocking Chairs, pair C.1-2

Date: ca. 1850-1860

Brief Description: Cane seated rockers, Cottage style, with back consisting of a cane panel below four turned spindles and a curved crest rail, cabriole front legs, outward flaring rear legs.

Location: In the south corners of the room.

Documentation: A drawing made for Leslie's Illustrated Newspaper. 1860-1861. (See also p. 81.)

Source: A chair, matching those shown in the Leslie's drawing, is in the collection at The Oaks, the home of Booker T. Washington, Tuskegee, Alabama. The chair was given to Tuskegee Institute with a history of having come from the Lincoln home. There is no available documentation to support this provenance;

SITTING ROOM: ROOM C

however, it is the only chair of this description with a Lincoln history. This chair should be reproduced and a pair placed in the sitting room. If possible, transfer of the rocker at The Oaks (which was not a part of the original furnishings while Booker T. Washington was alive) should be negotiated. LIHO 45 is appropriate until reproductions can be made, or a matching rocker for LIHO 45 found.

Object: Side Chairs, set of three C.3-4-5

Date: ca. 1850-1860

Brief Description: Flat sided cabriole front legs, canted rear legs, s-curved back with one horizontal splat; both splat and crest rail have decorative carving in the center, either cane seated or upholstered in striped fabric (cotton, linen, striped horsehair).

Location: One beneath west front window, one beneath the window on the south wall to the west of the fireplace, one on east wall south of the table.

Documentation: A drawing made for Leslie's Illustrated Newspaper, March 9, 1861.

Source: LIHO 41, 42, and 53.

SITTING ROOM: ROOM C

Object: Table C.6

Date: ca. 1850-1860

Brief Description: Large oval topped walnut table with cabriole legs and either scroll or claw and ball feet.

Location: East wall (could occasionally be moved to center of room for family grouping as was typical of the mid-nineteenth century).

Documentation: A drawing made for Leslie's Illustrated Newspaper, March 9, 1861. This table may have been the one purchased from the Lincolns in 1861 by J.M. Forden (who also purchased a sewing table from this same room), described in an 1894 sales catalogue as an "antique walnut tete-a-tete table." (See p. 74 for further discussion.) A "tete-a-tete" table was a table for conversation, designed to be placed free-standing in the middle of a room, more commonly referred to during the nineteenth century as a center table. The table shown in the Leslie's drawing is one of these conversation or center tables.

Source: To be acquired (antique); LIHO 40 may be used temporarily.

Object: Table Cover C.7

Date: ca. 1850-1860

SITTING ROOM: ROOM C

Brief Description: A rectangular table cover, of stenciled felt or wool.

Location: Walnut table.

Documentation: Period practice. Table covers were standard items at mid-century, particularly for center tables. Many period prints and paintings illustrate these covers. For example see Harold Peterson's Americans at Home (New York: Charles Scribner and Sons, 1971).

Source: To be acquired (antique or reproduction).

Object: Sewing Table C.8

Date: ca. 1850-1860

Brief Description: Two-drawer pedestal stand on rectangular base with feet.

Location: Between front windows.

Documentation: A drawing of the sitting room made for Leslie's Illustrated Newspaper, March 9, 1861; a table of this description now in the Lincoln Home (LIHO 1123) has a strong history of Lincoln ownership (see pp. 73-74).

Source: LIHO 1123.



SITTING ROOM: ROOM C

Object: Ironwork Flower Stand C.9  
Date: ca. 1850-1860  
Brief Description: Wire basket with handles mounted on trestle style ornate wire supports. (See Plate III.)  
Location: Beneath window on south wall, east of fireplace.  
Documentation: Drawing made for Leslie's Illustrated Newspaper, March 9, 1861.  
Source: To be acquired (antique or reproduction).

Object: Large Painting or Print with a Horse as part of subject C.10  
Date: 1840-1860  
Brief Description: Painting or print with a horse subject in a large rectangular wooden gilt frame, approximately 2'x3', hung with picture cord, and tassels.  
Location: East wall, center.  
Documentation: Drawing made for Leslie's Illustrated Newspaper, March 9, 1861.  
Source: LIHO 282.

Object: Mirror C.11  
Date: 1840-1860

SITTING ROOM: ROOM C

Brief Description: Large rectangular mirror in gilt frame, approximately 3½'x1½'.

Location: West wall between windows.

Documentation: Drawing made for Leslie's Illustrated Newspaper, March 9, 1861; a mirror similar to this one now back in the Lincoln Home has a well documented history of Lincoln ownership (see pp. 65-66).

Source: LIHO 1115.

Object: Girandole Set C.12

Date: 1840-1860

Brief Description: One five-arm candleholder and two single-arm candleholders, with hanging prisms.

Location: Multi-arm candleholder in center of mantel with two single-arm candleholders at either end.

Documentation: Drawing made for Leslie's Illustrated Newspaper, March 9, 1861. (See pp. 64-65 for discussion of two sets of original Lincoln girandole.)

Source: LIHO 263, 264, and 268.

Object: Pair of Vases C.13

Date: 1840-1860

SITTING ROOM: ROOM C

Brief Description: Double-handled vases on bases, French or English china.

Location: On either side of multi-arm candleholder next to single-arm candleholders.

Documentation: Drawing made for Leslie's Illustrated Newspaper, March 9, 1861.

Source: To be acquired (antique).

Object: Candleholder C.14

Date: ca. 1840-1860

Brief Description: Candlestick in the shape of a glass bottle or narrow vase (with a candle in it).

Location: Next to vase, to the right of the multi-arm candleholder.

Documentation: Drawing made for Leslie's Illustrated Newspaper, March 9, 1861.

Source: To be acquired (antique).

Object: Pair of Decanters C.15

Date: 1840-1860

Brief Description: Plain glass with stoppers, one with sloping shoulders, one with flat top.

SITTING ROOM: ROOM C

Location: Either side of multi-arm candleholder.  
Documentation: Drawing made for Leslie's Illustrated Newspaper, March 9, 1861.  
Source: To be acquired (antique).

Object: Basket of Apples (in season) C.16  
Date: 1850-1860  
Brief Description: A wicker basket filled with realistic artificial apples. Real apples, if left too long, might damage the basket.

Location: Oval table or sewing table.  
Documentation: Contemporary account (see p. 100).  
Source: To be acquired (reproduction).

Object: Spittoons C.17  
Date: 1850-1860  
Brief Description: Pair of spittoons in pewter, brass, or ceramic (not necessary that they be matched).  
Location: On each side of the fireplace.  
Documentation: Drawing made for Leslie's Illustrated Newspaper, March 9, 1861.  
Source: To be acquired (antique).

SITTING ROOM: ROOM C

Object: Stereoscope C.18  
Date: 1850-1860  
Brief Description: Stereoscope marked "A. Beckars, Patent April 7, 1857, Jas. Lee, N. Y. manufacturer."  
Location: Large oval table.  
Documentation: Lincoln associated (see pp. 93-94).  
Source: LIHO 273.

DINING ROOM: INTRODUCTION

The Lincolns' dining room table should be set to show an ordinary family meal--breakfast sometimes and late evening tea (dinner or supper) at other times. However, a festive table setting would be appropriate at holiday-time.<sup>6</sup>

Written references to the Lincolns' mealtime customs are sometimes contradictory; however, they do furnish some information:

He (Mr. L) was not a very early riser.... Mr. Lincoln was what I call a hearty eater and enjoyed a good meal as much as anyone I ever knew. I have often heard him say that he could eat corn cakes as fast as any two women could make them.

Lincoln used to go to bed ordinarily from ten to eleven o'clock....He rose early... breakfast was extremely frugal--an egg, a piece of toast, coffee, etc. At noon the President

took a little lunch--a biscuit, a glass of milk in winter, some fruit or grapes in summer. He dined at from five to six. He was very abstemious, ate less than anyone I know. Drank nothing but water, not from principle but because he did not like wine or spirits.

Mr. L was very fond of honey....He was a fast eater, though not a very hearty one.

Mrs. Lincoln's table was famed for the excellence of many rare Kentucky dishes, and in season it was loaded with venison, wild turkey, prairie chicken, quail, and other game which was then abundant.

According to Miss Leslie's Lady's House Book, which Mary owned, the manner of preparing a breakfast table differs but little from that of a tea table.<sup>11</sup> First, a cloth should be laid. Each place setting would consist of a plate, glassware, knife on the right with the blade inward, and fork and napkin to the left. A tea tray should be placed at one end of the table, where Mary could easily reach it. The tray would be arranged with slop bowl in the middle, hot water urn, teapot and coffeepot behind, sugar bowl on the right, creamer to the left, and the cups and saucers with the teaspoons to the right of the cup on the saucer.

Period illustrations and inventories show that not every room in a house would have contained lighting devices; therefore, no candlesticks or lamps are recommended for this room. When the table is set for an evening meal or festive occasion, candlesticks should be brought in from another room. (For a more detailed

discussion on period lighting, see K. Menz, "Lighting Devices Used in the American Home - 1840-1860," unpublished report, The Harpers Ferry Center, December, 1982.)

DINING ROOM: ROOM D

See p. 313, for Summary of Furnishings and Cost Estimates.

Object: Table D.1

Date: 1840-1860

Brief Description: Drop-leaf, walnut, Cottage style table with turned legs.

Location: Center of the room.

Documentation: The table now in the Lincoln dining room has a history of Lincoln ownership. It was one of several items purchased from them by Hugh Gallagher. (See pp. 75-76 for discussion.)

Source: LIHO 25.

Object: Chairs (8) D.2-9

Date: 1840-1850

Brief Description: Fancy chairs with stenciled crest rails, horizontal splat, rush seat, turned legs.

Location: Dining room, around the table and against the walls.

DINING ROOM: ROOM D

Documentation: (See pp. 57-59.) An examination of the chairs with a Lincoln history of ownership shows that the fancy chairs are the most likely to have been a set of dining room chairs in the Lincoln home. They have the strongest Lincoln provenance, since one came through the Oldroyd Collection, and fancy chairs, with rush or cane seats, were a practical choice for dining room furniture. They were often recommended by household advisories and chair manufacturers.

Source: LIHO 59, 66, 77, 79, 92, 98, 1061, 1190.

Object: Serving Table D.10

Date: 1840-1860

Brief Description: Late Empire style, pedestal, card table.

Location: Against south wall, on either side of window (depending on placement of heating duct).

Documentation: A card table with a history of Lincoln ownership descended to the family of one of Mrs. Lincoln's sisters. (See pp. 74-75 for provenance.)

Source: LIHO 29.

Object: Sideboard D.11

Date: 1840-1860



DINING ROOM: ROOM D

Brief Description: Cottage style, cherry or walnut, of local manufacture.

Location: East wall.

Documentation: Although the sideboard was a new furniture form for the well-to-do at the beginning of the nineteenth century, by mid-century, its popularity was widespread. For example, in Springfield in 1850, J. Hutchinson listed "side-boards" as part of his stock of items made at his manufactory (Daily Journal, Wednesday, January 2, 1850). It is not likely that the Lincolns would have omitted a sideboard from their dining room furnishings.

Source: LIHO 33.

Object: One Large Framed Print D.12

Date: 1840-1860

Brief Description: Subject should be a hunting scene in a period frame.

Location: South wall, east side of the window.

Documentation: Period practice. Dining room prints usually had a subject matter relating to food such as a fruit still life or a hunting scene.

Source: LIHO 180, a print depicting game birds is appropriate.

DINING ROOM: ROOM D

Object: One Large Framed Print or Watercolor D.13

Date: 1840-1860

Brief Description: Subject should be a hunting scene or still life in a period frame.

Location: South wall, west side of the window.

Documentation: Period practice. Dining room prints usually had a subject matter relating to food such as a fruit still life or a hunting scene.

Source: To be acquired (antique).

Object: Two Tablecloths, Twelve Napkins, D.14  
and One Crumb Cloth

Date: 1840-1850

Brief Description: A tablecloth and napkins of plain white cotton should be used for a breakfast setting and a tablecloth and napkins of plain white linen should be used for an evening tea or festive occasion. Crumb cloth to be made of light canvas or a heavy linen.

Location: To be placed on and under the dining room table.

Documentation: Records show that Mary Lincoln made several purchases in 1859 of tablecloths, table linen, and napkins (see pp. 98-100). Period practice indicates the use of a crumb cloth.

DINING ROOM: ROOM D

Source: One cotton tablecloth with six cotton napkins, and one linen tablecloth with six linen napkins, and a linen or canvas crumb cloth to be acquired (antique or reproduction).

Object: China D.15-16

Date: 1840-1850

Brief Description: Six plates and assorted serving pieces in transfer printed Staffordshire creamware or white ironstone.

Location: Plates to be used at each place setting and serving pieces to be used on the dining room table, sideboard, and serving table.

Documentation: The archeological excavations (documented on pp. 77-79) uncovered identifiable mid-nineteenth-century transfer printed Staffordshire creamware and ironstone shards in appropriate quantities to suggest the possibility that it was used by the Lincolns; along with shards of pressed glass from goblets and tumblers in patterns (such as flute and paneled) that were commonly used in mid-century households. Springfield City Directories for 1855-1859 include merchant advertisements for china, queensware, Brittainia ware, crockery, and glassware in plain pressed glass, cut, and Bohemian.

DINING ROOM: ROOM D

There is a transfer printed plate in the NPS collection (LIHO 192) that has a Lincoln association (see pp. 101-102 for documentation). It could be used on the table as a serving piece.

Also documented on pp. 101-102 are three other pieces of china in the NPS collection that supposedly came from the Lincolns' home--an ironstone bowl (LIHO 193), a creamware pitcher (LIHO 197), and a leaf-shaped ironstone serving dish (LIHO 195). Those pieces of china are characteristic of china in use at mid-century and would be appropriate on the table, although they should not be presented as Lincoln associated items, because of the absence of authentication. The NPS collection also contains four small plates, four dinner-size plates, a platter, and a covered vegetable dish (LIHO 1019-1028) in blue transferware. Those pieces are identified on the bottom with an elongated octagonal wreath and "Dawson." Dawson was produced by South, Hylton and Ford Potteries (ca. 1799-1864) of Sunderland, Durham, England.<sup>12</sup> That china does not have a documented Lincoln association but, like the china mentioned above, would be appropriate.

The NPS collection also contains some ironstone china (LIHO 212-254) that is identified as "sprig pattern." Various pieces are marked on the bottom in different ways--"REAL IRONSTONE CHINA;"

## DINING ROOM: ROOM D

PARIAN STONE;" and impressed into another is a hallmark with what looks like a lion on the left and a horse on the right, in the middle is a shield with "OPAQUE, GRANITE CHINA, W.H. & CO." That particular trade-mark is identified as belonging to Whittaker, Heath and Co., Hallfield Pottery, Hanley, Ca. 1892-8.<sup>13</sup> This china is, therefore, not appropriate for use in the Lincoln Home.

Source: To be acquired (antique). Two blue transfer ware dinner plates, marked "Dawson," would complete a set now in the LIHO Collection (LIHO 1019, 1021-1028). Another alternative is to purchase six plates of one of the earthenware types in the archeological excavations. A large number of plain white ironstone shards were uncovered in quantities which suggest the presence of a set, some with decoration in relief and some marked by Bridgwood and Clarke of Burslem. The Staffordshire Potteries of Bridgwood and Clarke, Churchyard Works, Burslem, made opaque porcelain between the mid-1850s and 1874. Decorated services of tableware were also available from Bridgwood and Clarke, impressed with the name and bearing a printed mark, the royal arms above PORCELAIN OPAQUE/ B & C/ BURSLEM.<sup>14</sup> China produced by the Joseph Clementson Staffordshire Potteries from 1839 to 1855 might also be considered. The leaf-shaped dish discussed on pp. 101-

DINING ROOM: ROOM D

102 was produced by that manufacturer and it supposedly belonged to the Lincolns.

Object: Tea Service and Tray D.17

Date: 1840-1850

Brief Description: One china tea service with cups and companion pieces as described on pp. 195-196, and a japanned tray.

Location: On the tea tray at one end of the dining room table.

Documentation: The tea service is recommended in Miss Leslie's Lady's House Book. There is no known description of the tea service that Mary Lincoln had in Springfield but there are written references to her having guests for tea.

Records also show that the Lincolns purchased quantities of tea and some tinware from local Springfield merchants. Transfer printed Staffordshire or white ironstone would be appropriate for the tea service, on the basis of archeological evidence and period practice. Painted (japanned) tinware was very popular in mid-century.

Source: To be acquired (antique to match plates discussed above).

DINING ROOM: ROOM D

Object: Glassware D.18-19

Date: 1850-1860

Brief Description: Six pressed glass goblets.

Location: At each place setting on the dining room table.

Documentation: The flint pressed glass goblets in the NPS collection do not have a documented Lincoln association but they are representative of the type commonly used in mid-century households and advertised in Springfield City Directories of the 1850s. Pressed glass shards were also uncovered in the archeological excavations.

Source: LIHO 1013-1016; two to be acquired (antique).

Object: Flatware D.20-21

Date: 1840-1850

Brief Description: Coin silver flatware (LIHO 1029-1040).

Location: At each place setting as described on pp. 195-196.

Documentation: There is no known description of the flatware used by the Lincolns in Springfield, except for the documentation given on p. 101. The coin silver flatware in the NPS collection

DINING ROOM: ROOM D

is a mid-century pattern produced by Gorham Manufacturing Company of Chicago and coin silver flatware was very popular and commonly used at the time.

Source: LIHO 1029-1040; two additional place settings to be acquired.

Object: Cake Stand D.22

Date: 1840-1850

Brief Description: A pressed glass cake stand.

Location: Sideboard.

Documentation: Period practice. Pressed glass was very popular at mid-century and it was advertised by local Springfield merchants. Pressed glass shards were also found in the archeological excavations. The pressed glass cake stand in the NPS collection supposedly belonged to Mary Lincoln; however, this association cannot be verified (see p. 103 for documentation).

Source: LIHO 255.

Object: Castor Set D.23

Date: 1840-1850



DINING ROOM: ROOM D

Brief Description: A silver plated or Brittaniaware castor set with glass condiment bottles.

Location: Sideboard. If the table is set for a festive occasion or a meal other than breakfast, the castor set should be placed on the table.

Documentation: Period practice. Castor sets were very common dining room accessories.

Source: LIHO 183-189.

KITCHEN-PORCH-STOREROOM: INTRODUCTION

Mary Lincoln's Springfield kitchen should contain furnishings that she accumulated between 1845 and 1861. Suggested furnishings in this plan are based on records of purchases of kitchen items made by the Lincolns at local Springfield stores, recommendations from a popular nineteenth-century housekeeping book that Mary Lincoln purchased, and information about kitchen furnishings manufactured in Illinois at the time.

By the late 1850s, the appearance of the kitchen (particularly in city homes like this one in Springfield) had changed with the advent of the cooking stove. Walls that had once been dark and smoky could be maintained white or a light color. Records show

that Lincoln hired John Roll in 1850 to whitewash walls.<sup>15</sup> In general, rooms were less smoky because the cooking fireplace was closed-up. Curtains were now being used to brighten city-kitchen windows and the ones in Mary Lincoln's kitchen should be made simply of check cloth or calico. Records show that the Lincolns purchased check cloth and calico in appropriate quantities for kitchen curtains.<sup>16</sup>

Lincoln scholars have written that Mary Lincoln was a woman of exceptional taste and that she delighted in furnishing her home in style.<sup>17</sup> There is a record of her purchasing Miss Leslie's Lady's House Book, as well as Miss Leslie's Directions for Cookery in Its Various Branches,<sup>18</sup> popular books on homemaking. Mary Lincoln was a frugal household manager and economized in the kitchen. In the nineteenth century, it was not uncommon to relegate older furnishings to the kitchen; and it is suggested that the Lincolns would have had some older furnishings (from their early years of marriage) in this room.

KITCHEN: ROOM E

See p. 316, for Summary of Furnishings and Cost Estimates.

<u>Object:</u>	Cook Stove, Wood Burning	E.1
<u>Date:</u>	1850-1860	

KITCHEN: ROOM E

Brief Description: The Iron Royal Oak cook stove (LIHO 559) has been described on p. 109 of this study and is appropriate for the kitchen.

Location: The stove should be installed against the chimney in the west wall of the kitchen.

Documentation: Iron stoves had been imported for use in Illinois since the 1830s and, in that same decade, iron foundries in the state were making cast-iron stoves for both cooking and heating. By mid-century, there were many producers of cast-iron products in Illinois.<sup>19</sup> In 1850, Lincoln hired a local contractor to close fireplaces and plaster them because he preferred wood-burning stoves.<sup>20</sup>

Source: LIHO 559.

Object: Stove Implements: Poker, E.2  
Lid Lifter, Ash Rake

Date: 1850-1860

Brief Description: Iron.

Location: By stove.

Documentation: Period practice.

Source: To be acquired (antique).

KITCHEN: ROOM E

Object: Heat Shield E.3  
Date: 1850-1860  
Brief Description: Square of zinc or tin.  
Location: To be placed under the cook stove.  
Documentation: Cook stoves were used continually during the day for cooking and heating and they became very hot. The floor under the stove was protected with a heat shield.  
Source: An appropriate shield is in the LIHO Collection, though it does not have a catalogue number.

Object: Work Table E.4  
Date: 1840-1850  
Brief Description: The work table should be of appropriate size to fit under the stairway (in front of the window for light), allowing room for the dry sink to be placed against the north wall. The table should have unfinished scrubbed top surface and either a plain tapered leg or a turned-style leg. Examples of early Illinois tables are shown on pp. 151, 175, and 235 of Betty Madden's recent book Arts, Crafts and Architecture in Early Illinois (1974).<sup>21</sup>

KITCHEN: ROOM E

Location: The table should be placed against the east wall.

Documentation: A worktable, for food preparation, was considered a necessity in the nineteenth-century kitchens. There is no known written reference to the table in Mary Lincoln's kitchen but, in Miss Leslie's Lady's House Book, two tables were recommended.<sup>22</sup> Only one table, however, is suggested in this plan because Mary's kitchen is small. Examples of Illinois-made worktables from the period survive and are shown in Madden, Arts...in Early Illinois.

Source: LIHO 125.

Object: Chair E.5

Date: 1840-1850

Brief Description: A painted side chair with rush seat.

Location: To be placed next to the work table.

Documentation: Period practice. A place to sit for the servant eating a meal or while preparing food was a standard kitchen furnishing. See illustrations in Harold Peterson's Americans at Home (New York: Charles Scribner and Sons, 1971).

Source: LIHO 1062.

KITCHEN: ROOM E

Object: Dry Sink E.6

Date: 1840-1850

Brief Description: The dry sink in nineteenth-century kitchens resembled a small cupboard. The recessed top was sometimes lined with metal and was large enough to hold a tub of water and dishes for washing. The doors below were usually paneled or vertical boards and they covered a storage area.

Location: The dry sink should be placed against the north wall, next to the outside door. Water from the well would be brought through that door.

Documentation: There is no known written reference to the sink in Mary Lincoln's kitchen; however, there is written reference to water being carried into the house from the backyard pump.<sup>23</sup> In addition, Miss Leslie's Lady's House Book does recommend sinks as a necessity for the kitchen<sup>24</sup> and examples of early Illinois-made dry sinks still exist. Appropriate illustrations can be found in Madden, Arts...in Early Illinois, p. 128.

Source: LIHO 118.

Object: Floor Cloth E.7

Date: 1855-1860

KITCHEN: ROOM E

Brief Description: Catherine Beecher in The American Woman's Home (1869), explains how to make an inexpensive oilcloth for the kitchen floor:

To procure a kitchen oilcloth as cheaply as possible, buy cheap tow cloth and fit it to the size and shape of the kitchen. Then have it stretched and nailed to the south side of the barn and, with a brush, cover it with a coat of thin rye paste. When this is dry, put on a coat of yellow paint and let it dry for a fortnight. Then put on a second coat...let it dry two months and it will last for many years.<sup>25</sup>

Easy-to-clean oilcloth was used on tables, shelves, and floors to catch spills.

Location: It is suggested that a square of oilcloth cover the entire floor area up to the visitor pathway.

Documentation: Miss Leslie's Lady's House Book recommended that there was "no better covering for a kitchen floor than a coarse, stout oilcloth in figured or plain color of blue, brown, olive, or yellow."<sup>26</sup> In Springfield newspapers, local nineteenth-century craftsmen advertised painted oilcloth<sup>27</sup> and records show that the Lincolns did purchase oilcloth.

Source: To be acquired (reproduction).

Object: Cupboard E.8

Date: 1840-1850

KITCHEN: ROOM E

Brief Description: In nineteenth-century kitchens cupboards were used for storage of utensils, such as pots, dishes, etc. They were usually large pieces of furniture, about three and one-half or four-feet wide, and about seven-feet high. There were shelves above and storage space under the work surface. Paneled doors usually covered both the storage space and the shelves.

Location: It is suggested that the cupboard be placed in the northwest corner of the kitchen (near the stove) against either wall.

Documentation: Written references to a cupboard in Mary's kitchen are discussed on pp. 110-112 of this study. Examples of Illinois-made nineteenth-century cupboards are shown in Madden, Arts...in Early Illinois, pp. 110, 128, 151, and 175.

Source: LIHO 117.

Object: Rocking Chair E.9

Date: 1840-1850

Brief Description: Ladder-back rocking chair with splint-weave seat.

Location: The rocking chair should be placed by the stove.



KITCHEN: ROOM E

Documentation: See p. 80 for information about the ladder-back rocking chair--it has a tradition of belonging to Mary Lincoln but it is not well documented. It is similar to nineteenth-century Illinois-made chairs shown in Madden, Arts...in Early Illinois, pp. 82, 98, 110, 150, 174, and 235. Making butter in the nineteenth-century manner was a long and slow process. Family members joined in and took turns sitting beside the butter churn and working at this chore. A comfortable chair would be considered a necessity.

Source: LIHO 126.

Object: Butter Churn E.10

Date: 1840-1850

Brief Description: Stoneware butter churn, made in Illinois.

Location: To be placed near the south door next to the rocking chair.

Documentation: Period practice. Stoneware articles for the kitchen are recommended in Miss Leslie's Lady's House Book.<sup>28</sup> Nineteenth-century Illinois potters produced butter churns and other utilitarian articles in stoneware for everyday use. Madden, in Arts...in Early Illinois, shows examples of Illinois butter churns on pp. 181-185.

KITCHEN: ROOM E

Source: To be acquired (antique); LIHO 480 can be used until an earlier one can be acquired.

Object: Open Shelves E.11

Date: 1850-1860

Brief Description: Small open shelves made of wood with closed-in sides and back, to be hung on the wall. It is suggested that the shelves be lined with oilcloth.

Location: Two sets of hanging shelves are suggested--one set for the northeast corner of the room (near the dry sink and table) and one set for the wall on the south side of the chimney.

Documentation: Nineteenth-century kitchens did not have built-in storage areas. In those days, open wooden shelves were hung on the wall to hold kitchen items and cooking supplies. Miss Leslie's Lady's House Book recommends lining shelves with oilcloth; and records show that the Lincolns did purchase oilcloth and bordering.<sup>29</sup>

Source: LIHO 548 and 549 (reproductions).

Object: Coffee Grinder E.12

Date: 1850-1860

KITCHEN: ROOM E

Brief Description: A grinder with crank handle should be hung in a convenient place.

Location: It is suggested that the grinder be placed near the dry sink and the work table where it would have been available for food preparation.

Documentation: Nineteenth-century homemakers seldom had a chance to buy products ready for the table. The general store usually sold coffee beans, salt, sugar, herbs, and spices that had to be ground before they could be used. There is no known written reference to the grinder but there is a record of food-stuffs being purchased by the Lincolns that would require use of this article. (See pp. 112-119 for the list.) Also, Miss Leslie's Lady's House Book, p. 235, recommends this item for the kitchen.

Source: LIHO 578.

Object: Knife Cleaning Box E.13

Date: 1850-1860

Brief Description: A hanging, rectangular wood knife cleaner and sharpener.

Location: To be placed near the dry sink and work table where it would be near at hand for food preparation.

KITCHEN: ROOM E

Documentation: Period practice. Miss Leslie's Lady's House Book, p. 235 recommends this item for the kitchen.

Source: LIHO 495.

Object: Spice Cabinet E.14

Date: 1850-1860

Brief Description: Small, hanging, wooden cabinet with eight drawers to hold spices.

Location: It is suggested that the spice cabinet be hung in the northwest corner of the kitchen near the cupboard and cook stove where it would have been readily available for preparing meals.

Documentation: Miss Leslie's Lady's House Book, p. 235 listed a spice cabinet and records show that the Lincolns did purchase spices and herbs which would need to be stored in a spice cabinet. (See pp. 112-119 for the list of foodstuffs.)

Source: LIHO 507.

Object: Salt Box E.15

Date: 1850-1860

Brief Description: A small, hanging, wooden salt container with a lid and curved front.

KITCHEN: ROOM E

Location: To be hung in the northwest corner of the kitchen near the cupboard and cook stove where it would have been readily available for preparing meals.

Documentation: Period practice. Miss Leslie's Lady's House Book listed a salt box as a necessity for the kitchen<sup>30</sup> and records show that the Lincolns did make salt purchases. (See pp. 112-119 for the list of foodstuffs.)

Source: LIHO 504.

Object: Broom E.16

Date: 1860

Brief Description: Broom with hickory handle.

Location: It is suggested that a broom be leaned against the wall beside the cupboard in the northwest corner of the kitchen.

Documentation: Brooms are listed among those items purchased by the Lincolns at nearby Springfield stores (see p. 117). Brooms are also listed among the kitchen necessities recommended in Miss Leslie's Lady's House Book, p. 238.

Source: LIHO 506.

KITCHEN: ROOM E

Object: Two Lamps E.17

Date: 1840-1860

Brief Description: Two small whale oil or lard lamps, blown glass or pewter.

Location: To be placed on the open shelves.

Documentation: Mrs. Lincoln purchased two lamps from Irwin and Co. for \$1.50 on April 16, 1844 (see p. 63). No lamps appear in the Leslie's Illustrated Newspaper, March 9, 1861 drawings of the parlors or sitting room. Lamps were often stored in the kitchen, where they were taken to be cleaned. They were placed in the rooms only when in use at night. See Abbott Lowell Cummings, ed. Rural Household Inventories (Boston: The Society for the Preservation of New England Antiquities), p. xxx; Martha Careful, Household Hints to Young Housewives (London: Dean and Son, 1852), p. 13; Margaret B. Schiffer, Chester County, Pennsylvania Inventories 1684-1850 (Exton, Pennsylvania: Schiffer Publishing Ltd., 1974), pp. 170-171.

Source: To be acquired (antique).

Object: Two Candleholders E.18

Date: 1840-1860

Brief Description: Iron or tin.

KITCHEN: ROOM E

Location: To be placed on the open shelves.

Documentation: Many candle purchases are listed among those items bought by the Lincolns at nearby Springfield stores (see pp. 112-119).

Source: To be acquired (antique).

Object: One Lantern on Wall Bracket E.19-20

Date: 1840-1860

Brief Description: Glass and tin with carrying handle.

Location: On a wall bracket near the north door for easy access when going outside.

Documentation: A glass lantern is listed among the items purchased by the Lincolns at nearby Springfield stores (see pp. 112-119). Miss Leslie's Lady's House Book, p. 235 also lists a lantern as a kitchen necessity.

Source: LIHO 502; the wall bracket to be acquired (antique or reproduction).

Object: Candlebox E.21

Date: 1840-1860

Brief Description: Tin, either plain or with punched decoration.

KITCHEN: ROOM E

Location: To be attached to the wall near the dry sink or any convenient space that is away from the heat of the stove.

Documentation: Many candle purchases are listed among those items bought by the Lincolns at nearby Springfield stores (see pp. 112-119). It was period practice to store candles in tin boxes hung on the wall to keep them away from vermin.

Source: To be acquired (antique).

Object: Utensils E.22

Date: 1840-1850

Brief Description: Nineteenth-century kitchen utensils included earthenware, ironware, tinware, woodenware, and basketry.

Location: Utensils should be chosen from those articles documented below and placed about the kitchen as recommended.

Documentation: Records show that the Lincolns made payments to tinware and other local merchants but no extensive list of articles is known (see pp. 112-119). In the nineteenth century, tinware, ironware, earthenware, woodenware, and basket items were all used in the kitchen. The following list is from Miss Leslie's Lady's House Book, pp. 233-240, and is included to document what utensils were recommended for nineteenth-century kitchens. However, the average homemaker had a minimum of small kitchen



KITCHEN: ROOM E

items and Mary Lincoln, a frugal household manager and economical in the kitchen, probably did not have an abundance of those items either:

Ironware:

Iron Pot	(LIHO 477)
Griddles (2)	(LIHO 524)
Iron Shovels	(LIHO 573, 574)
Iron Strainer	(LIHO 567)
Iron Turner	(LIHO 564, 572)
Iron Tongs	(LIHO 566)
Sadiron	(LIHO 553, 554, 555)
Waffle Iron	----
Bake Pans	----
Trivets	----
Skillets	(LIHO 561)
Ladles	----
Skewers	----
Toasting Iron	(LIHO 568)
Coffee Roaster	----
Tea Kettle	(LIHO 552)
Coffee Mill	(LIHO 578)
Kitchen Cleaver	----
Knives & Forks	(LIHO 439, 450-460)
Chopper	(LIHO 570, 575)
Spoons	----
Scales	(LIHO 436)
Iron Pot	(LIHO 551)

Tinware:

Pie Dishes	----
Cake Pans	----
Dozen Muffin Rings	----
Oval Cans	----
Lard Vessel	----
Butter Kettle	----
Sauce Pans	----
Roasting Pan	----
Colander	----

KITCHEN: ROOM E

Tinware: (Cont'd)

Fish Kettle	----
Egg Boiler	----
Apple Roaster	----
Pepper Box	----
Graters	----
Spice Boxes	(LIHO 536, 540)
Funnels	----
Scoops	----
Cups	----
Buckets	----
Coffeepot	----
Dippers	----
Pie Crimper	(LIHO 537)
Milk Bucket	(LIHO 517)
Apple Corer	(LIHO 538)
Pitcher	(LIHO 500)
Foot Warmer	(LIHO 479)
Tray	(LIHO 541)
Mold	(LIHO 543)

Copper:

Double Boiler	(LIHO 558)
Wash Boiler	(LIHO 584)
Brass Pot	(LIHO 483)
Funnel	(LIHO 569, 571)

Woodenware:

Buckets	----
Bread Board	(LIHO 440)
Sieves	----
Masher	----
Sleeve Board	(LIHO 514)
Egg Beater	----
Paste Board	----
Spoons	(LIHO 435, 437, 445, 563)
Sugar Boxes	(LIHO 481)
Salt Boxes	(LIHO 504)
Bread Box	(LIHO 583)

KITCHEN: ROOM E

Woodenware: (Cont'd)

Molds	(LIHO 442)
Cutlery Box	(LIHO 449, 495)
Towel Rack	(LIHO 120)
Box	(LIHO 519, 520)
Bowls	(LIHO 509, 510-513)
Mortar and Pestles	(LIHO 447, 448, 535)
Flyswitch	(LIHO 505)
Rolling Pin	(LIHO 443, 464, 492)
Coffee Stick	-----
Roller Towel Bar	(LIHO 582)
Tinder Box	-----
Sand Box	-----
Wooden Washboard	-----
Wooden Clothes Wringer	(LIHO 501)
Wood Rug Beater	(LIHO 503)

Basketware:

Market Basket	-----
Egg Baskets	(LIHO 372)
Bottle Basket	-----
Clothes Basket	-----
Storage Baskets	-----
Wisk Broom	(LIHO 515)
Demijohns for Vinegar and Molasses	-----

Earthenware:

Stoneware	(LIHO 426, 428, 430, 444, 550)
White Crockery	(LIHO 518, 577, 579, 580)
Brown Earthen Pans	(LIHO 466, 467, 469, 498, 499, 516, 581)

KITCHEN: ROOM E

Glassware:

Bottles	(LIHO 523, 525, 526, 527, 528, 529, 530, 531, 532, 533, 534)
Canning Jars	(LIHO 410, 413, 421, etc.)

Source: It is suggested that a few representative articles be selected from each category, be acquired (antique), and placed in the cupboard, on the open shelves, stove and work table. A wooden tub or bucket could be placed in the dry sink with a coarse towel hanging nearby as suggested in Miss Leslie's Lady's House Book, p. 230.

Object: Curtains E.23

Date: 1840-1860

Brief Description: Two pair, calico or check cloth, simple wood rods, on brackets.

Location: Windows in kitchen and storeroom.

Documentation: See Lincoln family fabric purchases in Harry E. Pratt, ed., "The Lincolns Go Shopping," Journal of the Illinois State Historical Society, Volume XLVIII, pp. 66-67.

Source: To be acquired (reproduction).

PORCH: ROOM E

Object: Wood Box E.24  
Date: 1840-1850  
Brief Description: Wooden chest-type box with a hinged lid.  
Location: On east porch, near the kitchen door.  
Documentation: Historians have referred to Lincoln chopping wood and carrying it in to replenish the wood box.<sup>31</sup> Wood boxes were usually in the kitchen where the wood was handy to the stove but Mary Lincoln's kitchen is small and the wood box was likely to have been outside on the porch. An 1865 stereoscope view of the east elevation of the Lincoln home shows what appears to be a wood box on the back porch.<sup>32</sup>  
Source: LIHO reproduction.

STOREROOM: ROOM E

Object: Icebox E.25  
Date: 1840-1850  
Brief Description: Iceboxes were made by eastern carpenters using local woods. They were plain, square insulated boxes with a tin lining to help retain the cool air and to make them water-tight. There was a compartment in the top for the block of ice and space below for storing foodstuffs.

STOREROOM: ROOM E

Location: In the kitchen today, refrigerators are near-at-hand but Mary Lincoln's icebox probably was not because her kitchen would have been too warm. Cooking and baking in Mary's kitchen was a daylong process, during which the stove gave off a tremendous amount of heat. If the icebox were in the kitchen, the ice would melt quickly and stored food would spoil. It is suggested that Mary Lincoln kept her icebox in the cool storeroom.

Documentation: Iceboxes were being used early in the nineteenth century. One of the first insulated iceboxes was patented in 1803 and, by 1840, eastern manufacturers were marketing them from the seaboard to Illinois.<sup>33</sup> In addition, Carl Sandburg, in his Lincoln biography, discusses transactions that Mary Lincoln had with the iceman.<sup>34</sup>

Source: To be acquired (antique).

Object: Pie Safe E.26

Date: 1840-1850

Brief Description: The pie safe was a cupboard for storing baked goods. It was about five-and-one-half feet tall and about three feet wide, standing on short legs. The sides and doors were

STOREROOM: ROOM E

paneled tin, punched in decorative designs and allowing circulation of air.

Location: It is suggested that the pie safe be in the storeroom where baked goods would cool and stay fresh.

Documentation: See pp. 110-112 for references to a cupboard for storing baked goods. Miss Leslie's Lady's Home Book also recommends a safe for the kitchen. Madden, Arts...in Early Illinois, p. 135, shows an example of one that was made in Illinois in 1840-1850.

Source: To be acquired (antique).

Note: This plan does not recommend a flour bin (for storage of large amounts of flour) because there is no documentation to suggest that the Lincolns used one. Additionally, the Royal Oak stove in Mary's kitchen has a small oven and it would not accommodate large quantities of baked items. It is suggested that the Lincolns probably purchased baked goods from a local Springfield baker.

Object: Laundry Supplies E.27

Date: 1840-1850

STOREROOM: ROOM E

Brief Description: Washing laundry in the nineteenth century required a number of articles that are documented below.

Location: Storeroom.

Documentation: In Miss Leslie's Lady's House Book, p. 8, it is recommended that washing be done once a week. The equipment included a tub to catch rainwater for laundry, washboard, clothes baskets, starch pans, lines, kettles, boiler to heat water, clotheshorse, lye, tin ladle, hickory stick to stir clothes, mangle, and a linen or ticking laundry bag which should be hung up-- if left on the floor it could be injured by mice or cockroaches. It is suggested that a few representative articles from the above list be placed in the storeroom.

Source: To be acquired (antique).

FIRST FLOOR HALL: ROOM F

See p. 319, for Summary of Furnishings and Cost Estimates.

Object: Hall Stand F.1

Date: ca. 1850-1860

Brief Description: Gothic style with small mirror, umbrella holder, and hat pegs.

Location: North wall.



FIRST FLOOR HALL: ROOM F

Documentation: A well-documented Gothic hall stand from the Bateman family is now in the Lincoln Home collection. (See p. 62 for provenance.)

Source: LIHO 51.

Object: Two Prints F.2

Date: ca. 1840-1860

Brief Description: Religious or romantic subject matter.

Location: South wall.

Documentation: Period practice.

Source: To be acquired (antique).

Object: Hall Chair F.3

Date: ca. 1850-1860

Brief Description: Gothic style.

Location: North wall.

Documentation: A Gothic hall chair descended in the Bateman family with a history of Lincoln ownership. (See p. 62 for provenance.)

Source: To be acquired (antique).

FIRST FLOOR HALL: ROOM F

Object: Umbrella F.4  
Date: ca. 1850-1860  
Brief Description: Bone or wooden handled black cloth umbrella.  
Location: Hall stand.  
Documentation: Period practice.  
Source: An appropriate umbrella is in the LIHO collection, though it does not have a catalogue number.

Object: Two Canes F.5  
Date: ca. 1850-1860  
Brief Description: Two wooden walking canes.  
Location: Hall stand.  
Documentation: Period practice. The well-documented hall stand (LIHO 51) was designed to hold umbrellas and canes. Canes were also standard articles of dress. Their use was not limited to the elderly and infirm.  
Source: To be acquired (antique).

Object: Wall Lamp F.6  
Date: ca. 1850-1860  
Brief Description: Glass oil lamp in cast-iron bracket.

FIRST FLOOR HALL: ROOM F

Location: North wall.

Documentation: On November 29, 1849, the Lincolns purchased a wall lamp from J. Bunn & Co. (see p. 63).

Source: To be acquired (antique).

WINDOW HANGINGS: FIRST FLOOR: ROOMS A-D

Object: Cloth Shades and Cotton A.45; B.16  
Damask Draperies; Brass C.22; D.26  
Valances, Brass Tiebacks

Date: Modern reproductions.

Brief Description: The off-white or buff shades should be on wooden rollers. The draperies should be hung from a brass rod hidden beneath a metal cornice and tied back with brass tiebacks. The base of the curtains should rest on the floor, overlapping approximately an inch. Colors of the draperies should correspond to a color in the carpeting, such as a crimson, green, or blue, etc. Draperies in the parlors should be the same color and fabric. The sitting room and dining room should be different colors but could also be cotton damask.

Location: First floor windows.

Documentation: Light colored shades and dark draperies may be seen in the front windows of the parlor and sitting room in

WINDOW HANGINGS: FIRST FLOOR: ROOMS A-D

the 1860 photograph of the Lincoln home taken during a Republican rally. One written reference (see p. 38) indicates that there were green shades in the Lincoln home. The photographic evidence is a more reliable source and; therefore, buff or white shades are recommended. (See p. 144 for Lincoln purchase of drapery material, cotton damask, 36 yards.)

See drawings of parlors and sitting room made for March 9, 1861, Leslie's Illustrated Newspaper for style of drapery.

There is no documentation for the dining room; therefore, it should be furnished similarly to the parlors and sitting room. Nor is there documentation for the front door sidelights. The present treatment is acceptable.

Source: To be acquired (reproduction). Good quality reproduction fabrics are currently available from several New York fabric supply houses. It is recommended that the modern fabrics now hanging be replaced.

FLOOR COVERINGS AND WALLPAPER: FIRST FLOOR: ROOMS A-D, F

PARLORS

Object: Brussels Carpet A.42; B.13

Date: ca. 1850-1860

FLOOR COVERINGS AND WALLPAPER: FIRST FLOOR: ROOMS A-D, F

Brief Description: The carpeting should be reproduced from mid-nineteenth-century examples, similar in design to the Leslie's Illustrated Newspaper drawings. By basing the reproduction on an actual example, a more successful treatment of color and design can be achieved. The front and back parlors have the same design.

Location: Wall-to-wall.

Documentation: Leslie's Illustrated Newspaper, March 9, 1861. (See pp. 145-147 for discussion of original evidence for floor coverings.)

Source: To be acquired (reproduction).

Object Three Rugs A.43; B.14

Date: ca. 1850-1860

Brief Description: Two hearth rugs and one smaller area rug, hooked, yarn sewn, or small pieces of matching Brussels.

Location: Hearths and in front of the table between the windows in the front parlor.

Documentation: Leslie's Illustrated Newspaper, March 9, 1861. (See pp. 145-147 for discussion of original evidence for floor coverings.)

Source: To be acquired (antique, if possible).

FLOOR COVERINGS AND WALLPAPER: FIRST FLOOR: ROOMS A-D, F

Object: Wallpaper A.44; B.15

Date: ca. 1850-1860

Brief Description: The wallpaper should be reproduced similar in design to the Leslie's Illustrated Newspaper drawings and the 1865 stereoscope views but (if possible) should be based on actual period wallpapers.

Location: All walls.

Documentation: Leslie's Illustrated Newspaper, March 9, 1861. (See pp. 147-149 for a discussion of original evidence for wallpapers.)

Source: To be acquired (reproduction).

SITTING ROOM

Object: Ingrain Carpet C.19

Date: ca. 1850-1860

Brief Description: The carpeting should be reproduced from mid-nineteenth-century examples, similar in design to the Leslie's Illustrated Newspaper drawings. By basing the reproduction on an actual example, a more successful treatment of color and design can be achieved.

Location: Wall-to-wall.

FLOOR COVERINGS AND WALLPAPER: FIRST FLOOR: ROOMS A-D, F

Documentation: Leslie's Illustrated Newspaper, March 9, 1861.  
(See pp. 145-147 for discussion of original evidence for floor coverings.)

Source: To be acquired (reproduction).

Object: Hearth Rug C.20

Date: ca. 1850-1860

Brief Description: One hooked hearth rug.

Location: Hearth.

Documentation: Leslie's Illustrated Newspaper, March 9, 1861.  
(See pp. 145-147 for discussion of original evidence for floor coverings.)

Source: To be acquired (antique).

Object: Wallpaper C.21

Date: ca. 1850-1860

Brief Description: The wallpaper should be reproduced similar in design to the Leslie's Illustrated Newspaper drawings but (if possible) should be based on actual period wallpapers.

Location: All walls.

FLOOR COVERINGS AND WALLPAPER: FIRST FLOOR: ROOMS A-D, F

Documentation: Leslie's Illustrated Newspaper, March 9, 1861.

(See pp. 147-149 for a discussion of original evidence for wallpapers.)

Source: To be acquired (reproduction).

DINING ROOM

Object: Ingrain Carpet D.24

Date: ca. 1850-1860

Brief Description: The household guides recommend that dining room ingrains be dark colored.

Location: Wall-to-wall.

Documentation: Period practice. Dining rooms did not usually have expensive floor coverings because of food spillage and because the dining room in the average house was not one of the formal rooms used for entertaining. In houses smaller than the Lincolns, the dining room often doubled as back parlor or family sitting room.

Source: To be acquired (reproduction).

Object: Wallpaper D.25

Date: ca. 1850-1860



FLOOR COVERINGS AND WALLPAPER: FIRST FLOOR: ROOMS A-D, F

Brief Description: It is recommended that the design of the wallpaper for this room be similar to the one shown in the 1865 stereoscope view but based on an actual period wallpaper.

Location: All walls.

Documentation: See pp. 145-149 for a discussion of the original evidence for wallpaper in the Lincoln home.

Source: To be acquired (reproduction).

HALLWAY

Object: Brussels Carpet F.7

Date: ca. 1850-1860

Brief Description: A dark colored Brussels carpet in a period pattern with colors corresponding to wallpaper.

Location: Wall-to-wall.

Documentation: Period practice. Hallway floor coverings during the mid-nineteenth century were usually floor cloth, rag or venetian, or ingrain carpet. The more expensive Brussels was rarely used in areas of high traffic. Brussels, however, is recommended here because of the heavy visitor traffic. The more appropriate floor coverings would not withstand heavy usage.

Source: To be acquired (reproduction).

FLOOR COVERINGS AND WALLPAPER: FIRST FLOOR: ROOMS A-D, F

Object: Wallpaper F.8  
Date: ca. 1850-1860  
Brief Description: A period design suitable for a hallway (i.e. a geometric pattern) should be reproduced.  
Location: All walls.  
Documentation: See pp. 147-149 for a discussion of the original evidence for wallpaper in the Lincoln home.  
Source: To be acquired (reproduction).

BEDROOMS: INTRODUCTION

According to tradition, Lincoln's bedroom was the front room over the parlor. The room should be furnished to reflect Lincoln's occupancy with such personal items as shaving equipment, his lap desk, and his traveling trunk. The room, however, also should be furnished more formally than the back rooms as was customary for the period since it is a front chamber. Records also show that on at least one occasion, Lincoln received visitors in a bedroom with a high post bed. (See p. 43 for the contemporary account.)

The furnishings in this room are well documented. The wallpaper is original to the Lincoln period; a stereoscope view taken in 1865 shows Lincoln's bed and washstand, which had been purchased

by the Tiltons. Furthermore, a Waud drawing of the room, also made in 1865, suggests other period furnishings and a room arrangement which may have been similar to Lincoln's own arrangement of the furniture. (See p. 119 for further discussion of original evidence.)

The present location of the furniture in the stereoscope view is now unknown; however, there are several pieces of bedroom furniture--beds, bureaus, and wardrobes--with well-documented histories of ownership by the Lincolns. This report recommends making use of the Lincoln associated furniture wherever possible. However, if a period "Elizabethan style" bedstead and washstand can be located, they should replace the bedstead and washstand in Mr. Lincoln's bedroom. (There is no certainty that the bed and washstand shown in the 1865 view were originally in Lincoln's own bedroom. Another possibility is that after Lincoln's death, these items took on a legendary association with Lincoln's bedroom; therefore, costly reproduction of the bedstead and washstand is not recommended.)

The evidence for furnishing the other bedrooms is based on the survival of pieces of furniture with a history of Lincoln ownership. Period sources (noted in the bibliography) are greatly relied upon with an emphasis on those recommendations made by Eliza

Leslie in her Lady's House Book (1846), because Mrs. Lincoln herself owned a copy of this popular housekeeping manual.

All beds should have appropriate bed linen (see pp. 98 and 144 for documentation), Marseilles quilts, or chintz coverlets. According to Miss Leslie's Lady's House Book (pp. 316-317), the following procedure should be used in preparing a bed:

Spread on the under sheet, tucking it in all round under the sides of the mattress; so as to keep it smooth and even, and to prevent its wrinkling, dragging, and getting out of place during the night. If it has a white linen case, shake up the bolster well, and lay it on after the under sheet. If it has no case, draw up this sheet more to the head, and tuck it well over the back of the bolster, but do not stretch the under sheet tightly, so as to drag the bolster down at night, causing it to get beneath the shoulders of the sleeper. Lay it easy, and put it with your hands into the hollow between the bolster and the bed. Next, spread on the upper sheet, tucking it well under the bottom, lest it get out of place at night. You need not tuck it at the two sides, as you did the under sheet. Then, if there are blankets, lay them on smoothly, securing them in place by tucking them in at the bottom and at the lower corners. Next, put on the spread or counterpane, taking care to have it smooth and even, and turning it down at the head with the upper sheet. Then, beat up the pillows and lay them in their places, the open ends outwards.

Lighting devices were not common bedroom furnishings during the mid-nineteenth century. Period inventories, for example, rarely list candlesticks in the bedrooms and even more rarely lamps.<sup>35</sup>

Period illustrations also show that lighting devices do not always appear in every room.<sup>36</sup> Kitchens and hallways more often contained the necessary lighting devices. At night candlesticks and lamps would be carried from these areas to those rooms where needed.

The available evidence on lighting in the Lincoln home indicates that the primary illuminant was candlelight. (See pp. 112- 119.) The use of candles as the main light source was characteristic of the period. Only two inexpensive lamps appear in the Lincolns' purchase records. Therefore, according to period practice and the available evidence on lighting in the Lincoln home, few lighting devices have been recommended for the Lincoln home bedrooms. (For a more detailed discussion on period lighting, see K. Menz, "Lighting Devices Used in the American Home - 1840-1860," unpublished report, The Harpers Ferry Center, December, 1982.)

MR. LINCOLN'S BEDROOM: ROOM G

See p. 320, for Summary of Furnishings and Cost Estimates.

<u>Object:</u>	Bedstead	G.1
<u>Date:</u>	ca. 1840-1860	
<u>Brief Description:</u>	High post bedstead.	
<u>Location:</u>	East wall.	

MR. LINCOLN'S BEDROOM: ROOM G

Documentation: See pp. 120-125 for discussion of Lincoln beds. The stereoscopic view, labeled "Lincoln's bed," shows a high post spool turned oak bedstead in the "Elizabethan" style purchased by the Tiltons from the Lincolns. The location of this bed is now unknown; however, it is believed to have been destroyed along with the Tiltons' other furniture in the Chicago Fire.

Source: LIHO 57. An Empire style, carved, high post bed now in the Lincoln bedroom should be replaced when possible by a spool turned oak bed more closely resembling the Tilton one. To be acquired (antique).

Object: Bedding and Bedclothes G.2

Date: ca. 1840-1860

Brief Description: Mattress, two feather pillows, two sheets, two pillowcases, and a bolster.

Location: Bed.

Documentation: Period practice, see Eliza Leslie's Miss Leslie's Lady's House Book (pp. 316-317) and see pp. 98 and 144 for references to fabrics purchased and owned by the Lincolns.

Source: To be acquired (reproduction or antique).

MR. LINCOLN'S BEDROOM: ROOM G

Object: Bedsread G.3  
Date: ca. 1840-1860  
Brief Description: A Marseilles quilt.  
Location: Bed.  
Documentation: The Lincolns' account with John Williams & Co. lists the purchase of a Marseilles quilt on February 9, 1853 (see p. 98).  
Source: LIHO 808.

Object: Three Books G.4  
Date: ca. 1840-1860  
Location: Table.  
Documentation: See pp. 48-52 for list of Lincoln's reading material.  
Source: LIHO sources.

Object: Springfield Newspapers and G.5  
Other Assorted Papers  
Date: ca. 1840-1860  
Brief Description:  
Location: Table.

MR. LINCOLN'S BEDROOM: ROOM G

Documentation: See pp. 48-52 for lists of Lincoln's reading material.

Source: To be acquired (reproduction).

Object: Candlesticks G.6

Date: ca. 1840-1860

Brief Description: A pair, pressed glass.

Location: Bureau and writing table.

Documentation: Period practice.

Source: LIHO 299 and 300.

Object: Three Razors G.7-8

Date: ca. 1830-1860

Brief Description: Three long-handled shaving razors.

Location: Washstand

Documentation: Period practice. Men usually had more than one razor.

Source: LIHO 341, two to be acquired (antique).

Object: Razor Strop G.9

Date: ca. 1830-1860



MR. LINCOLN'S BEDROOM: ROOM G

Brief Description: Wood and leather strop for sharpening long-bladed razors.

Location: Washstand.

Documentation: Period practice, a part of standard shaving equipment.

Source: LIHO 1057.

Object: Mug and Soap G.10-11

Date: ca. 1830-1860

Brief Description: Small shaving mug with soap.

Location: Washstand.

Documentation: Period practice, a part of standard shaving equipment.

Source: LIHO 343, soap to be acquired (reproduction).

Object: Shaving Brush G.12

Date: ca. 1830-1860

Brief Description: Wooden handled brush with natural bristles.

Location: Washstand.

Documentation: Period practice, a part of standard shaving equipment.

Source: To be acquired (antique).

MR. LINCOLN'S BEDROOM: ROOM G

Object: Patent Model G.13  
Date: ca. 1840  
Brief Description: Wooden model.  
Location: Mantelpiece.  
Documentation: Copy of original patent model at the Smithsonian Institution, Museum of American History.  
Source: To be acquired (reproduction).

Object: Shaving Mirror G.14  
Date: ca. 1840-1860  
Brief Description: Mahogany veneered oval mirror with scroll-cut decoration and shelf.  
Location: West wall (between windows, above washstand).  
Documentation: Period practice.  
Source: LIHO 69, which has a tradition of Lincoln ownership, although it is not well documented, would be appropriate.

Object: Toilet Set to include Wash Bowl, Pitcher, Soap Dish, and Chamber Pot G.15  
Date: ca. 1840-1860  
Brief Description: Ironstone, white, a matched set.

MR. LINCOLN'S BEDROOM: ROOM G

Location: Washstand. The chamber pot should be placed in the washstand cupboard. Chamber pots would be in sight only during the night.

Documentation: Period practice.

Source: To be acquired (antique).

Object: Footbath G.16

Date: ca. 1840-1860

Brief Description: Tin.

Location: Near washstand.

Documentation: Period practice.

Source: LIHO 332.

Object: Slop Bucket G.17

Date: ca. 1840-1860

Brief Description: Tin.

Location: Near washstand.

Documentation: Period practice.

Source: LIHO 331.

Object: Water Can G.18

Date: ca. 1840-1860

MR. LINCOLN'S BEDROOM: ROOM G

Brief Description: Tin.

Location: Near washstand.

Documentation: Period practice.

Source: LIHO 333.

Object: Towel Horse G.19

Date: ca. 1840-1860

Brief Description: Wood, turned, of local manufacture.

Location: Near washstand.

Documentation: Period practice.

Source: LIHO 68.

Object: Bureau G.20

Date: ca. 1840-1860

Brief Description: Late Empire style, mahogany bureau, with upper tier of three small drawers on a body of four drawers.

Location: Northeast corner.

Documentation: See pp. 128-133 for discussion of Lincoln bureaus.

Source: LIHO 1122.

MR. LINCOLN'S BEDROOM: ROOM G

Object: Wardrobe G.21

Date: ca. 1840-1860

Brief Description: Double door, walnut wardrobe.

Location: South wall, to the west of door from hall.

Documentation: See pp. 137-138 for discussion of Lincoln wardrobes. Wardrobe, LIHO 58, is well documented, having descended in the Melvin family along with its original bill of sale from Lincoln to Dr. Samuel Melvin.

Source: LIHO 58.

Object: Washstand G.22

Date: ca. 1840-1860

Brief Description: Washstand with drawer and double doors beneath, "Elizabethan" or Cottage style marble top.

Location: West wall, between windows.

Documentation: A washstand of this description appears in the 1865 stereoscope view of the Tiltons' parlor bedchamber with the label "Lincoln's washstand" (see p. 119).

Source: LIHO 90.

Object: Side Chairs (2) G.23

Date: ca. 1840-1860

MR. LINCOLN'S BEDROOM: ROOM G

Brief Description: Late Empire style, with cane seats.

Location: In front of the table in the northwest corner and in front of north window (near east wall).

Documentation: Two chairs appear in the illustrations of the Tilton parlor chamber. The Tilton room arrangement is likely to have been similar to the Lincolns'.

Source: LIHO 31 and 32.

Object: Table G.24

Date: ca. 1840-1860

Brief Description: Small, round pedestal table (3' diameter) or small rectangular table.

Location: Northwest corner of room.

Documentation: Period practice. A table for writing purposes, holding books, etc., is likely to have been in the bedroom. The Waud drawing of the Tilton bedroom pictures such a table. Lincoln's lap desk (see p. 136) should be placed upon this table.

Source: To be acquired (antique).

Object: Table Cover G.25

Date: ca. 1840-1860

MR. LINCOLN'S BEDROOM: ROOM G

Brief Description: Green baize table cover, approximately 3'6" x 4' or 3'6" in diameter.

Location: On the small table in northwest corner.

Documentation: Period practice. Green baize table covers were commonly used to provide a writing surface and protect the table.

Source: To be acquired (reproduction).

Object: Mirror G.26

Date: ca. 1840-1860

Brief Description: Wooden, ogee molded frame, approximately 2½' high x 1½' wide.

Location: Over bureau.

Documentation: Period practice. Miss Leslie wrote in 1850 that small movable looking glasses were "now much out of favor." A large glass hung upon the wall was preferred. A mirror appears over the bureau in the Tilton parlor chamber (see pp. 119-120).

Source: LIHO 61.

Object: Two Prints G.27

Date: ca. 1840-1860

MR. LINCOLN'S BEDROOM: ROOM G

Brief Description: A pair of rectangular ogee molded walnut frames, approximately 18" high x 12" wide; subject matter should be historical or political figures.

Location: Over fireplace, hung with picture cord from picture.

Documentation: Period practice.

Source: LIHO 325, 326.

Object: Bootjack G.28

Date: ca. 1840-1860

Brief Description: Wooden bootjack with extended handle.

Location: Near wardrobe.

Documentation: Period practice.

Source: LIHO 334.

Object: Two Dresser Scarves G.29

Date: ca. 1840-1860

Brief Description: White fringed cloths.

Location: On the bureau and washstand.

Documentation: Period practice.

Source: To be acquired (antique).



MR. LINCOLN'S BEDROOM: ROOM G

Object: Lap Desk G.30

Date: ca. 1840-1860

Brief Description: Walnut writing desk.

Location: Table.

Documentation: Period practice. A lap desk is the kind of personal item often located in the bedroom.

Source: LIHO 308. (See p. 136 for the provenance of this lap desk with a history of Lincoln ownership.)

Object: Stove G.31

Date: ca. 1840-1860

Brief Description: Cast-iron, wood-fueled, heating stove.

Location: In front of the fireplace so that the stove-pipe can be connected to the chimney flue.

Documentation: Period practice. The March 9, 1861 Leslie's Illustrated Newspaper drawing shows a parlor stove in the front parlor and Mr. Lincoln wrote two small checks to Springfield stove merchants in 1859. (See p. 119.) These references show that stoves were in use in the house, although there is no evidence to indicate the number of stoves in use.

Source: LIHO 330.

MR. LINCOLN'S BEDROOM: ROOM G

Object: Shovel, Tongs, Stand G.32  
Date: 1850-1860  
Brief Description: Iron and brass.  
Location: Set by stove.  
Documentation: Period practice.  
Source: LIHO 327, 328, 329.

Object: Hearth Brush G.33  
Date: 1850-1860  
Brief Description: Wooden hearth brush with natural bristles.  
Location: In the fire tool stand (LIHO 327).  
Documentation: Period practice.  
Source: To be acquired (antique).

Object: Collar Box and Collars G.34  
Date: 1850-1860  
Brief Description: Circular wooden or cardboard box, approximately 6 inches to 8 inches in diameter and 2½ inches to 3½ inches high containing linen, starched and pressed collars.  
Location: Bureau top.  
Documentation: Period practice.  
Source: To be acquired (antique if possible).

GUEST ROOM: ROOM H

See p. 324, for Summary of Furnishings and Cost Estimates. According to tradition, the south front bedroom was a guest room. (See discussion p. 8.)

Object: Bedstead H.1

Date: ca. 1840-1860

Brief Description: Mahogany, French bedstead.

Location: East wall.

Documentation: Period practice. See pp. 121-122 for discussion of a bedstead (LIHO 71) which descended in the Binnian family with a history of having come from the Lincoln home. The style of this bedstead is more fashionable and it is made of a more expensive wood than the cottage bedsteads described for the other chambers. It is appropriate for the front bedroom reserved for guests.

Source: LIHO 71.

Object: Bureau and Mirror H.2-3

Date: ca. 1840-1850

Brief Description: Late Empire style bureau, mirror to be mahogany veneered, approximately 2½' x 1½'.

Location: West wall between windows and mirror over bureau.

GUEST ROOM: ROOM H

Documentation: Period practice; see also pp. 128 through 133 for discussion of bureaus with a history of Lincoln ownership.

Source: LIHO 60 and 91.

Object: Wardrobe H.4

Date: ca. 1840-1860

Brief Description: Large, late Empire style wardrobe.

Location: North wall.

Documentation: Period practice. See pp. 137 through 138 for a discussion of wardrobes with a history of Lincoln ownership.

Source: LIHO 76.

Object: Washstand H.5

Date: ca. 1840-1850

Brief Description: Late Empire style, with enclosed lower shelf.

Location: South wall in southeast corner.

Documentation: Period practice.

Source: LIHO 67.

Object: Rocking Chair and Footstool H.6-7

Date: ca. 1840-1860

Brief Description: Cane seated rocker with upholstered footstool.

GUEST ROOM: ROOM H

Location: In front of southeast window.

Documentation: Period practice.

Source: LIHO 64, LIHO 20.

Object: Print H.8

Date: ca. 1840-1860

Brief Description: Lithograph or engraving in wood frame approximately 2'x 2½'.

Location: To be hung over mantel.

Documentation: Period practice.

Source: LIHO 381.

Object: Print H.9

Date: ca. 1840-1860

Brief Description: Lithograph or engraving in wood frame approximately 1½'x 1'.

Location: To be hung on the east wall.

Documentation: Period practice.

Source: To be acquired (antique).

Object: Wash Basin H.10

Date: ca. 1840-1860

GUEST ROOM: ROOM H

Brief Description: Ironstone, white.

Location: Washstand.

Documentation: Period practice.

Source: To be acquired (antique).

Object: Mug H.11

Date: ca. 1840-1860

Brief Description: Ironstone, white.

Location: Washstand.

Documentation: Period practice.

Source: To be acquired (antique).

Object: Pitcher and Soap Dish H.12

Date: ca. 1840-1860

Brief Description: Ironstone, painted china.

Location: Washstand.

Documentation: Period practice.

Source: LIHO 385, 384.

Object: Slop Jar H.13

Date: ca. 1840-1860

Brief Description: Ironstone.

GUEST ROOM: ROOM H

Location: Near washstand.

Documentation: Period practice.

Source: LIHO 1056.

Object: Stool H.14

Date: ca. 1840-1860

Brief Description: Crude wooden stool.

Location: Near washstand.

Documentation: Period practice.

Source: LIHO 48.

Object: Dresser Scarves (2) H.15

Date: ca. 1840-1860

Brief Description: White fringed rectangular cloth.

Location: Bureau and small stand.

Documentation: Period practice.

Source: To be acquired (antique).

Object: Vase H.16

Date: ca. 1840-1860

Brief Description: French or English painted ceramic vase.

GUEST ROOM: ROOM H

Location: Stand or mantel.  
Documentation: Period practice.  
Source: To be acquired (antique).

Object: Water Bottle and Tumbler H.17

Date: ca. 1840-1860

Brief Description: Glass.

Location: Washstand or bureau.

Documentation: Period practice.

Source: To be acquired (antique).

Object: Pin Cushion H.18

Date: ca. 1840-1860

Brief Description: Small velvet cornered pillow.

Location: Bureau.

Documentation: Period practice.

Source: To be acquired (antique).

Object: Bedding and Bedclothes H.19

Date: ca. 1840-1860

Brief Description: Mattress, bolster, two feather pillows, two sheets, and two linen pillowcases.



GUEST ROOM: ROOM H

Location: Bed.

Documentation: Period practice, see Eliza Leslie's Miss Leslie's Lady's House Book (pp. 316-317) and see pp. 98 and 144 for references to fabrics purchased and owned by the Lincolns.

Source: To be acquired (mattress, pillows, bolster to be reproductions; linen pillowcases and sheets to be antique).

Object: Bedspread H.20

Date: ca. 1840-1860

Brief Description: Quilted cotton chintz, a reproduction fabric in an historic pattern.

Location: Bed.

Documentation: Period practice. Chintz was recommended by authors, such as Eliza Leslie, for bedrooms only. See p. 144 for account of Mrs. Lincoln's purchase of 10½ yds. of French chintz for \$3.00 from John William & Co.

Source: To be acquired (reproduction).

Object: Stove H.21

Date: 1840-1860

Brief Description: Cast-iron heating stove.

GUEST ROOM: ROOM H

Location: Fireplace.

Documentation: Period practice.

Source: LIHO 374.

Object: Shovel, Tongs, Hearth Brush H.22

Date: 1850-1860

Brief Description: Iron and brass, and wooden hearth brush.

Location: Set by stove.

Documentation: Period practice.

Source: To be acquired (antique).

Object: Sofa, Lounge H.23

Date: 1840

Brief Description: Black horsehair, tufted half back.

Location: North wall, east of doorway.

Documentation: Period practice. See pp. 71-72 for history of Lincoln ownership.

Source: LIHO 13.

MRS. LINCOLN'S BEDROOM: ROOM I

See p. 327, for Summary of Furnishings and Cost Estimates.

Object: Bedstead I.1

Date: ca. 1840-1860

Brief Description: Low post, Cottage style with turned spindles.

Location: East wall.

Documentation: Period practice.

Source: LIHO 101.

Object: Bedding and Bedclothes I.2

Date: ca. 1840-1860

Brief Description: Mattress, bolster, two feather pillows, two sheets, and two linen pillowcases.

Location: Bed.

Documentation: Period practice, see Eliza Leslie's Miss Leslie's Lady's House Book (pp. 316-317) and see pp. 98 and 144 for references to fabrics purchased and owned by the Lincolns.

Source: To be acquired (mattress, pillows, bolster to be reproductions; linen pillowcases and sheets to be antique).

Object: Bedspread I.3

Date: ca. 1840-1860

Brief Description: A Marseilles quilt.

MRS. LINCOLN'S BEDROOM: ROOM I

Location: Bed.

Documentation: The Lincolns' account with John Williams & Co. lists the purchase of a Marseilles quilt on February 9, 1853 (see p. 98).

Source: LIHO 828.

Object: Bureau I.4

Date: ca. 1820-1840

Brief Description: Federal style bureau, reeded pilasters, and a swell front.

Location: West wall, north of door to Abraham's room.

Documentation: This bureau has a history of ownership by Mrs. Lincoln. See pp. 129-131.

Source: LIHO 1126.

Object: Pair of Wooden Brackets I.5

Date: ca. 1850-1860

Brief Description: A pair of small wooden shelves with scroll-work decoration.

Location: Either side of mirror over dressing table.

Documentation: Period practice.

Source: LIHO 694 and 695.

MRS. LINCOLN'S BEDROOM: ROOM I

Object: Commode I.6  
Date: ca. 1840-1860  
Brief Description: Mahogany veneered box.  
Location: Southeast corner.  
Documentation: Period practice. This commode has a history of ownership by Mrs. Lincoln. See pp. 125-127.  
Source: LIHO 104.

Object: Washstand I.7  
Date: ca. 1840-1860  
Brief Description: Late Empire style.  
Location: South wall, near door.  
Documentation: Period practice.  
Source: LIHO 106.

Object: Rocking Chair and Footstool I.8-9  
Date: ca. 1840-1860  
Brief Description: Walnut lady's rocker and stool, caned or upholstered in black horsehair.  
Location: At foot of bed near north window and table.  
Documentation: Period practice.  
Source: LIHO 56 and LIHO 96.

MRS. LINCOLN'S BEDROOM: ROOM I

Object: Sewing Table I.10  
Date: ca. 1840-1860  
Brief Description: Small pedestal stand, with drawers.  
Location: North wall near window.  
Documentation: Period practice.  
Source: LIHO 46.

Object: Mirror I.11  
Date: ca. 1840-1860  
Brief Description: Mahogany veneered, ogee molded wooden frame.  
Location: Over washstand.  
Documentation: Period practice.  
Source: LIHO 103.

Object: Pair of Brackets I.12  
Date: ca. 1840-1860  
Brief Description: Wooden, scrollwork decoration.  
Location: Either side of mirror over washstand.  
Documentation: Period practice.  
Source: LIHO 727 and 728.

MRS. LINCOLN'S BEDROOM: ROOM I

Object: Oval Picture I.13

Date: ca. 1840-1860

Brief Description: Oval wooden frame with hair, shellwork, or pressed flower subject.

Location: Over commode on south wall.

Documentation: Period practice.

Source: LIHO 706.

Object: Framed Pictures, Pair I.14

Date: 1850-1860

Brief Description: Photographs of Tad and Willy, framed and hung over bureau.

Location: Over bureau.

Documentation: Period practice. See "Accessory Furnishings" (pp. 104-107) which lists several photographs of family members and friends which have a history of having been located in the Springfield house. Framed photographs were frequently hung on the walls. Many still have their original attachments by which they were hung. One example in a gutta percha frame may be seen at the House Where Lincoln Died, The National Park Service, Washington, D.C.<sup>37</sup> Written references to this practice are rare; however, one reference is located in the letters of Louise Taft,

MRS. LINCOLN'S BEDROOM: ROOM I

about President Taft's boyhood home in Cincinnati. In a letter written in September, 1860, Louise described a new photograph of William Howard, taken on his third birthday, "hanging" before her. It was a full length photograph mounted in a gilt oval frame.<sup>38</sup>

Source: LIHO 392 and 393.

Object: Bowl, Pitcher, Soap Dish, I.15  
and Slop Jar

Date: ca. 1840-1860

Brief Description: Ironstone, white.

Location: Washstand.

Documentation: Period practice. Archeological evidence (see pp. 77-79). Purchases (see p. 98).

Source: To be acquired (antique).

Object: Cologne Bottles (2) I.16

Date: ca. 1840-1860

Brief Description: Glass or French china.

Location: Dressing table.

Documentation: Period practice. See list of the Lincolns' local store purchases.

Source: LIHO 722 and 723.



MRS. LINCOLN'S BEDROOM: ROOM I

Object: Pin Cushion I.17  
Date: ca. 1840-1860  
Brief Description: Cloth covered cushion with pre-1860 pins.  
Location: Dressing table.  
Documentation: Period practice.  
Source: To be acquired (antique).

Object: Dresser Scarves (2) I.18  
Date: ca. 1840-1860  
Brief Description: White cotton fringed cloths.  
Location: Bureau and washstand.  
Documentation: Period practice.  
Source: To be acquired (antique).

Object: Candlesticks I.19  
Date: ca. 1840-1860  
Brief Description: Parian, pair.  
Location: One on the dressing table, and one on the bureau.  
Documentation: Period practice and candle purchases made by the Lincolns (see pp. 112-119).  
Source: LIHO 350, 351.

MRS. LINCOLN'S BEDROOM: ROOM I

Object: Wicker Sewing Basket I.20

Date: ca. 1850-1860

Brief Description: Oval basket with short sides and lid.

Location: Chair or sewing table.

Documentation: Mrs. Lincoln sewed many of her own and her children's clothes (see p. 114). LIHO 278 (now in such poor condition, it should be retired to storage) has a history of ownership by Mrs. Lincoln. See pp. 67-68.

Source: LIHO 1003.

Object: Towels I.21

Date: ca. 1840-1860

Brief Description: Cotton.

Location: Washstand.

Documentation: See list of local purchases made by the Lincolns, pp. 98-100.

Source: To be acquired (antique).

Object: Vase or Statuette I.22

Date: ca. 1840-1860

Brief Description: English or French china.

MRS. LINCOLN'S BEDROOM: ROOM I

Location: Bureau.

Documentation: Period practice.

Source: LIHO 699.

Object: Brush and Comb I.23

Date: ca. 1840-1860

Brief Description: Wooden handled.

Location: Dressing table.

Documentation: Period practice.

Source: To be acquired (antique).

Object: Jewelry I.24

Date: ca. 1840-1860

Brief Description: Woven hair ornaments (2).

Location: Dressing table.

Documentation: Period practice.

Source: LIHO 714, 715, 716, 717, 718.

Object: Wool Shawl I.25

Date: ca. 1850

Brief Description: Pink and yellow wool shawl.

MRS. LINCOLN'S BEDROOM: ROOM I

Location: Hung over the chair.

Documentation: This shawl has a history of ownership by Mrs. Lincoln. See p. 104.

Source: LIHO 744.

Object: Framed Cutout Pictures I.26

Date: ca. 1850-1860

Brief Description: Cutout pictures of Georgian period; people mounted on black background.

Location: Over Mary's bed on east wall.

Documentation: Period practice.

Source: LIHO 729, 730, 731.

Object: Books I.27

Date: Pre-1860

Brief Description: Period books of various topics.

Location: Sewing table and bureau.

Documentation: Period practice. See books owned by Mary Lincoln, pp. 52-53.

Source: LIHO Collections, such as 943, 880, 946, to be periodically rotated.

MRS. LINCOLN'S BEDROOM: ROOM I

Object: Piece of Unfinished Sewing I.28

Date: ca. 1850-1860

Brief Description: Hand sewing on linen, cotton or wool, preferably to be partially finished.

Location: Sewing table, or chair.

Documentation: Period practice.

Source: To be acquired (antique preferable).

Object: Foot Tub I.29

Date: ca. 1860

Brief Description: White glazed earthenware vessel with oval base, wide molded bands, and square handles. Marked "Anthony Shaw/Burslem."

Location: Floor, near washstand.

Documentation: NPS catalogue record states an employee was told in 1965 that the object belonged to Lincoln, but there is no other documentary evidence to support the claim. Godden (1964) places Anthony Shaw in Tunstall during the years 1851 to 1856, and in Burslem during the years "ca. 1860" to 1900. The Lincoln provenance for this item is questionable but possible.

Source: LIHO 768.

MRS. LINCOLN'S BEDROOM: ROOM I

Object: Writing Box and Writing Equipment I.30  
Date: ca. 1840-1860  
Brief Description: Slant-top box, mahogany or walnut, with hinged top and interior drawers; pens, paper, envelopes.  
Location: On top of bureau.  
Documentation: Period practice.  
Source: To be acquired (antique).

Object: Stove I.31  
Date: 1840-1860  
Brief Description: Small parlor stove suitable for room.  
Documentation: Period practice.  
Source: LIHO 705.

Object: Shovel, Tongs, Hearth Brush I.32  
Date: 1850-1860  
Brief Description: Iron and brass, and wooden hearth brush.  
Location: Set by stove.  
Documentation: Period practice.  
Source: To be acquired (antique).

MRS. LINCOLN'S BEDROOM: ROOM I

Object: Dressing Table I.33  
Date: 1840-1860  
Brief Description: Small table with drawers and mirror, walnut or mahogany.  
Documentation: Period practice.  
Source: To be acquired (antique).

BOYS' ROOM: ROOM J

See p. 330, for Summary of Furnishings and Cost Estimates.

This room should be furnished as if two of the Lincoln boys slept in it. Tad turned five in 1858, and Robert went to Exeter (and then Harvard) beginning in the summer of 1859. While Robert was away, it is most likely that one or both of the younger boys slept in this back bedroom. While Robert was at home, unless there was a visitor, it is probable that the front bedroom was also used. The children's belongings and toys, however, were most likely confined to the back bedroom. There is no need to have a wardrobe in every room and, considering the small size of this room, a wardrobe is not recommended.

Object: Bedstead and Bedclothes J.1  
Date: ca. 1840-1860

BOYS' ROOM: ROOM J

Brief Description: Low post Cottage style bedstead with spool turned posts and legs.

Location: West wall centered.

Documentation: Period practice. No evidence of original furnishings.

Source: LIHO 88 (antique).

Object: Bedding and Bedclothes J.2

Date: ca. 1840-1860

Brief Description: Mattress, bolster, two feather pillows, two sheets, and two linen pillowcases.

Location: Bed.

Documentation: Period practice, see Eliza Leslie's Miss Leslie's Lady's House Book (pp. 316-317) and see p. 144 for references to fabrics purchased and owned by the Lincolns.

Source: To be acquired (mattress, pillows, bolster to be reproductions; quilt, sheets, and pillowcases to be antique).

Object: Bedspread J.3

Date: ca. 1840-1860

Brief Description: A coverlet or quilt.



BOYS' ROOM: ROOM J

Location: Bed.

Documentation: Period practice. There are also two references in the Lincolns' store accounts to the purchase of quilts, one a Marseilles quilt; the other a reference to purchasing chintz and batting, fabric and stuffing for making a quilt (see pp. 98 and 144).

Source: LIHO 801.

Object: Bureau J.4

Date: ca. 1840-1860

Brief Description: Late Empire style, walnut.

Location: East wall.

Documentation: Five extant bureaus have a history of Lincoln ownership; therefore, all bedrooms except one (probably the maid's) would have contained bureaus. See pp. 128-133 for discussion of Lincoln bureaus.

Source: LIHO 102.

Object: Side Chair J.5

Date: ca. 1840-1860

Brief Description: Late Empire or Cottage style.

BOYS' ROOM: ROOM J

Location: South wall.

Documentation: Period practice and oral tradition.

Source: LIHO 35.

Object: Washstand J.6

Date: ca. 1840-1850

Brief Description: Cottage style washstand with cut out for bowl, drawer and shelf beneath; locally made, of cherry, walnut, ash, or sycamore.

Location: South wall.

Documentation: Period practice.

Source: To be acquired (antique).

Object: Washbowl, Pitcher, and Chamber Pot J.7

Date: ca. 1840-1850

Brief Description: Ironstone set (if possible).

Location: Washstand.

Documentation: Period practice.

Source: To be acquired (antique).

Object: Mirror J.8

Date: ca. 1840-1860

BOYS' ROOM: ROOM J

Brief Description: Mahogany veneered frame, approximately 2½' x 1½'.

Location: Over bureau.

Documentation: Period practice.

Source: LIHO 84.

Object: Print J.9

Date: ca. 1840-1860

Brief Description: Framed, subject matter should appeal to small boys, i.e., animals or military subjects.

Location: West wall.

Documentation: Period practice.

Source: To be acquired (antique).

Object: Print J.10

Date: ca. 1840-1860

Brief Description: Framed, subject matter should appeal to small boys, i.e., animals or military subjects.

Location: East or south wall.

Documentation: Period practice.

Source: To be acquired (antique).

BOYS' ROOM: ROOM J

Object: Dresser Scarf J.11  
Date: ca. 1840-1860  
Brief Description: White fringed rectangular cloth.  
Location: Top of bureau.  
Documentation: Period practice.  
Source: To be acquired (antique).

Object: Two Brushes and Combs J.12  
Date: ca. 1840-1860  
Brief Description: Wooden, with natural bristles.  
Location: Top of bureau.  
Documentation: Period practice.  
Source: To be acquired (antique).

Object: Two Toothbrushes J.13  
Date: ca. 1840-1860  
Brief Description: Wooden, with natural bristles.  
Location: On washstand.  
Documentation: A wooden toothbrush was found in the archeological excavations (see p. 79); period sources also mention bone-handled toothbrushes.  
Source: To be acquired (antique or reproduction).

BOYS' ROOM: ROOM J

Object: Boys' Toys (4) J.14  
Date: ca. 1840-1860  
Brief Description: Tin or wooden. Suggested items are toy soldiers, a bow and arrow, marbles, train.  
Location: Bureau, bed, floor, or shelves and toy trunk.  
Documentation: Period practice. Robert was a member of the Springfield cadets; military toys would be appropriate in the room. Marbles were found in the archeological excavations (see p. 79).  
Source: To be acquired (antique).

Object: Boys' Clothing J.15  
Date: 1840-1860  
Brief Description: Pants, jackets, shirts, collars, etc.  
Location: Bed or chair.  
Documentation: Period practice.  
Source: To be acquired (antique).

OPTIONAL

Object: Wall Shelves J.16  
Date: Nineteenth century  
Brief Description: Two-tiered shelf.

BOYS' ROOM: ROOM J

Location: South wall, west of window.

Documentation: Period practice.

Source: LIHO 549.

Object: Toy Chest J.17

Date: ca. 1820-1860

Brief Description: Wooden box with lid.

Location: South wall.

Documentation: Period practice.

Source: LIHO 87.

Object: Table J.18

Date: ca. 1840-1860

Brief Description: Wood table.

Location: West wall, north of bed.

Documentation: Period practice.

Source: LIHO 75.

MAID'S ROOM: INTRODUCTION

The servant's room should be sparsely furnished with objects of a slightly older style than the other bedroom furnishings because

the older, less fashionable furniture in the house would have been the most appropriate for hired help. A few personal items, such as a pin cushion and cologne bottle, should indicate that the Lincolns' servant was a woman. (See pp. 14-17 for a discussion of the Lincolns' servants.)

In an affidavit (Appendix IV) by Robert Kuecher listing his family's Lincoln artifacts, he recalled that his father purchased several items which had come from the maid's room at the Lincoln home. Kuecher reportedly bought a washstand, white toilet set, quilt, and a picture of a church and yard. Although Kuecher's statements cannot be documented (see pp. 138-141 for discussion of Kuecher artifacts), his memory of the contents of the maid's room does correspond to what household guidebooks recommended for the servant's room. Eliza Leslie in her Lady's House Book, a copy of which was owned by Mrs. Lincoln, advised the housekeeper to furnish the servant's room with a painted low post bedstead, a piece of carpet in winter, a washing table, a looking glass, several chairs, and a closet or pegs for clothes.<sup>39</sup>

MAID'S ROOM: ROOM K

See p. 333, for Summary of Furnishings and Cost Estimates.

<u>Object:</u>	Low Post Bedstead	K.1
<u>Date:</u>	ca. 1830-1850	

MAID'S ROOM: ROOM K

Brief Description: Low post painted bedstead, made of a local wood (cherry, walnut, ash, or sycamore).

Location: Against west wall.

Documentation: No evidence of original furnishings; based on period practice.

Source: LIHO 113.

Object: Bedding and Bedclothes K.2

Date: ca. 1840-1860

Brief Description: Mattress, one feather pillow, two sheets, one coarse linen pillowcase, and a wool blanket. No bedspread is recommended.

Location: Bed.

Documentation: Period practice, see Eliza Leslie's Miss Leslie's Lady's House Book (pp. 316-317) and see p. 144 for references to fabrics purchased and owned by the Lincolns.

Source: To be acquired (mattress and pillow to be reproductions; sheets, pillowcase, and blanket to be antique if possible).

Object: Washstand K.3

Date: ca. 1830-1850



MAID'S ROOM: ROOM K

Brief Description: Plain Cottage washstand with turned supports and a cut out for washbowl and lower shelf; made of local wood (cherry, walnut, sycamore, or ash).

Location: Against east wall.

Documentation: Kuecher affidavit; present location unknown. (See Appendix IV and p. 138.) Period practice.

Source: LIHO 114.

Object: Wardrobe K.4

Date: ca. 1830-1850

Brief Description: Plain with paneled doors, shelves, and pegs, and turned or bracket feet; made of a local wood (cherry, walnut, ash, or sycamore).

Location: Against east wall.

Documentation: Period practice. A wardrobe of this description has a history of Lincoln ownership (see p. 138, Lincoln Memorial Collection wardrobe) and would be appropriate for this room.

Source: LIHO 1124.

Object: Chair, Rocker K.5

Date: ca. 1830-1850

MAID'S ROOM: ROOM K

Brief Description: Caned seat and back.

Location: Against east wall.

Documentation: Period practice. One chair of this description with a history of Lincoln ownership are located in the Lincoln Home collection and would be appropriate for this room.

Source: LIHO 47.

Object: Side Table K.6

Date: ca. 1830-1850

Brief Description: Two-drawer stand with turned legs, made from a local wood (cherry, walnut, ash, or sycamore).

Location: North wall, near bedstead.

Documentation: Period practice; no evidence of original furnishings.

Source: LIHO 95.

Object: Trunk K.7

Date: ca. 1830-1850

Brief Description: Chest on drawered stand.

Location: West wall.

MAID'S ROOM: ROOM K

Documentation: Period practice; no evidence of original furnishings; a common method of storage. This chest has a history of Lincoln ownership (see pp. 127-128) and would be appropriate for this room.

Source: LIHO 97.

Object: Print K.8

Date: ca. 1830-1850

Brief Description: A large print, in a plain wood frame, approximately 1½' x 2½', hung from a hidden nail, with a religious subject matter.

Location: Over bed, north wall.

Documentation: Period practice; no evidence of original furnishings. (See p. 138 and Appendix IV for evidence of Kuecher picture from maid's room.)

Source: LIHO 749.

Object: Mirror K.9

Date: ca. 1830-1850

Brief Description: Small mirror in a plain frame.

Location: Over washstand, east wall.

MAID'S ROOM: ROOM K

Documentation: Period practice; no evidence of original furnishings.

Source: LIHO 115.

Object: Chamber Pot, Slop Jar, and Pitcher K.10

Date: ca. 1830-1850

Brief Description: White ironstone, need not be a matched set.

Location: Washstand, slop jar on floor nearby, chamber pot at foot of bed.

Documentation: Period practice; ironstone fragments were found in the privy excavations.

Source: LIHO 753, Chamber Pot; LIHO 754, Slop Jar.

Object: Washbowl and Pitcher K.11

Date: ca. 1830-1850

Brief Description: Ironstone.

Location: Washstand.

Documentation: Period practice, ironstone fragments were found in the privy excavations.

Source: To be acquired (antique).

MAID'S ROOM: ROOM K

Object: Cologne or Patent Medicine Bottle K.12

Date: ca. 1840-1860

Brief Description: One molded glass bottle.

Location: For table near bed.

Documentation: Period practice; a variety of bottles were found in the privy excavation and one would be appropriate for the servant's room.

Source: LIHO 761.

Object: Pin Cushion K.13

Date: ca. 1840-1860

Brief Description: Small, cloth covered pin cushion with pins.

Location: For table near bed.

Documentation: Period practice.

Source: To be acquired (antique).

Object: Brush and Comb K.14

Date: ca. 1840-1860

Brief Description: Wooden comb and brush set.

Location: For table near bed.

Documentation: Period practice.

Source: To be acquired (antique).

MAID'S ROOM: ROOM K

Object: Bed Warmer Pan K.15  
Date: ca. 1840-1860  
Brief Description: Brass pan with wood handle.  
Location: Near bed.  
Documentation: Period practice.  
Source: LIHO 760.

HALLWAY: SECOND FLOOR: ROOM L  
See p. 334, for Summary of Furnishings and Cost Estimates.

Object: Chair L.1  
Date: ca. 1860  
Brief Description: Reproduction plank bottom, bamboo turned legs, painted.  
Location: South wall, alcove area.  
Documentation: Reproduction chair for NPS interpreter use.  
Source: To be acquired (reproduction).

Object: Mirror L.2  
Date: ca. 1855-1860  
Brief Description: Tall mirror, either Rococo revival, or Gothic style with bracket shelf at base.

HALLWAY: SECOND FLOOR: ROOM L

Location: North wall, alcove area.

Documentation: Period practice.

Source: To be acquired (antique).

Object: Stand L.3

Date: ca. 1850-1860

Brief Description: Pedestal stand with round top (approximately one-foot diameter).

Location: Southwest corner.

Documentation: See p. 89 for original evidence of stands owned by the Lincolns. A flower stand also appears in the Leslie's illustration of the sitting room.

Source: To be acquired (antique).

Object: Hall Chair L.4

Date: ca. 1850-1860

Brief Description: One Gothic side chair.

Location: In front of window.

Documentation: One Gothic hall chair with a history of Lincoln ownership descended in the Bateman family and it is possible

HALLWAY: SECOND FLOOR: ROOM L

the Lincolns owned others (see p. 63). Period practice for hallway furnishings.

Source: To be acquired (antique).

Object: Prints (2) L.5

Date: ca. 1850-1860

Brief Description: Subject matter should be romantic or religious (suitable for a Presbyterian).

Location: North and south walls, west of door to guest room.

Documentation: Period practice.

Source: To be acquired (antique).

Object: Vase L.6

Date: ca. 1850-1860

Brief Description: French or English porcelain (with flowers, artificial or real).

Location: Mirror shelf.

Documentation: Period practice.

Source: To be acquired (antique).



HALLWAY: SECOND FLOOR: ROOM L

Object: Plant L.7  
Date: Type in vogue, ca. 1850-1860  
Brief Description: Ivy in a terra cotta pot.  
Location: Stand.  
Documentation: Period practice.  
Source: To be acquired (modern).

WINDOW HANGINGS: SECOND FLOOR: ROOMS G-L

Object: Cloth Shades and G.35; H.24; I.34  
Muslin Curtains J.19; K.16; L.8  
Date: Modern reproductions; style of 1850-1860.  
Brief Description: The shades should be on wooden rollers. The curtains should be hung from simple brass rods supported by brass brackets. For an example see Webster's Encyclopedia of Domestic Economy, p. 250, fig. 163.  
Location: All windows on the second floor. Maid's room should have shades only.  
Documentation: An 1860 photograph of the Lincoln home during the passing of a Republican rally clearly shows buff or white colored linen shades in all the front windows of the house.<sup>40</sup> One written reference (see p. 38) indicates that there were green shades in the Lincoln home. The photographic evidence is a more

WINDOW HANGINGS: SECOND FLOOR: ROOMS G-L

reliable source and; therefore, buff or white shades are recommended. The shades should be the same color in every room.

Muslin curtains were commonly used in second floor windows in average middle-class homes, and, because there is no evidence of fancier drapery, these curtains are recommended for use in the Lincoln bedrooms. The curtains may vary in pattern from room to room. Plain white would also be appropriate.

Source: To be acquired (reproduction). Good quality reproduction fabrics are currently available from several New York fabric supply houses. It is recommended that the modern fabrics now hanging be replaced.

FLOOR COVERINGS AND WALLPAPER: SECOND FLOOR: ROOMS G-L

HALLWAYS, STAIRS

Object: Carpet (modern, of commercial grade) L.9

Date: ca. 1850-1860

Brief Description: Many modern Brussels carpets have patterns similar to ingrain patterns. One of these should be used. A suitable alternative would be a plain color taken from the bedroom ingrains.

FLOOR COVERINGS AND WALLPAPER: SECOND FLOOR: ROOMS G-L

Location: First and second floor hallways, stairway.

Documentation: Period practice. Hallway floor coverings during the mid-nineteenth century were usually floor cloth, rag or venetian, or ingrain carpet. The more expensive Brussels carpeting was not usually used in these areas of heavy traffic, except in the homes of the very well-to-do. Even in the White House, Mrs. Lincoln used six yards of oilcloth at the front entrance (probably a vestibule area). Oilcloth, rag, and ingrain carpet, however, are all fragile types of floor covering and will not withstand very well the constant visitor traffic at the Lincoln Home. These types of floor coverings are also not readily available today and reproduction is very costly. Brussels carpet is more readily available, less expensive, and much sturdier.

Source: To be acquired (antique).

Object: Wallpaper L.10

Date: 1850-1860

Brief Description: Second floor hallway papers should be a continuation of the paper used in the first floor hallway.

Location: Second floor hallways.

FLOOR COVERINGS AND WALLPAPER: SECOND FLOOR: ROOMS G-L

Documentation: Period practice, and see pp. 147-149 for evidence of wallpaper used at the Lincoln home.

Source: To be acquired (reproduction).

BEDROOMS

The second floor, with the exceptions of the boys' room and maid's room, should be carpeted with reproduction ingrain carpeting, each room wall-to-wall. A higher quality ingrain in a pattern different from that used in the other rooms should be used in the two front bedrooms. Mary's room can be of the same pattern. The boys' and maid's rooms should have a piece of rag carpeting, not wall-to-wall. A section of the carpeting now in the maid's room is suitable.

Most of the ingrain carpeting in place at this time appears to date from the last quarter of the nineteenth century and is not suitable for the Lincoln Home. One exception is the carpeting in Mrs. Lincoln's bedroom. This carpet could remain in place until its condition becomes too poor for exhibit purposes.

Object: Rag Carpeting J.20; K.17

Date: ca. 1850-1860

Location: Boys' room and the maid's room.

FLOOR COVERINGS AND WALLPAPER: SECOND FLOOR: ROOMS G-L

Brief Description: Plain woven striped carpeting filled with wefts of either rags or woolen yarn.

Documentation: Period practice. Rag carpeting was the least expensive alternative for floor coverings.

Source: To be acquired (reproduction).

BEDROOMS (Lincoln's Room, Guest Room, Mary's Room, and Boys' Room)

Object: Wallpaper H.26; I.35; J.21

Date: ca. 1850-1860

Brief Description: All papers should be reproductions based on period designs (with the exception of Lincoln's room, the paper of which should remain).

Location: Guest room, Mary's room, and the boys' room.

Documentation: See pp. 147-149 for a discussion of the original evidence for wallpaper in the Lincoln home.

Source: To be acquired (reproduction).

FOOTNOTES TO SECTION E

1. Caroline Owsley Brown, "Springfield Society Before the Civil War," The Journal of the Illinois State Historical Society, XV, nos. 2-2, (July, 1909), p.480.

2. Advertisement, J. A. Hough, Illinois Daily Journal, May 11, 1849.

3. Advertisement, J. Hutchinson, Illinois Daily Journal, January 2, 1850.

4. Ibid., January 6, 1857.

5. Andrew Jackson Downing, The Architecture of Country Houses (New York: Dover Publications, Inc., 1969), p. 429.

6. There is little evidence concerning the Lincolns' holiday traditions. One reference indicates that they did have turkey at Thanksgiving. An article in the New York Tribune, December 1 referring to November 29, 1860, stated, "Mr. Lincoln, like the rest of Anglo-American mankind, feasted on roast turkey, and having special cause to thank his Maker, attended Divine Service," quoted in William Baringer, Lincoln Day by Day (Washington, 1960), p. 299. Christmas was celebrated in Springfield by a giving of gifts according to the Journal of Anna Ridgeley (Journal of the Illinois State Historical Society, XXII, no. 5, October, 1929, pp. 401-446). Valentine's Day was another holiday celebrated in Springfield. A Birchall and Owens' advertisement in the Illinois State Daily Journal, February 13, 1850, read, "We anticipate that a thousand of these quiet, delicate and pleasing tokens of regard will be sent about in this city tomorrow." For further information on holiday decorations, see Katherine Menz, "Holiday and Family Celebrations in the Early Nineteenth Century," unpublished report, Harpers Ferry Center, The National Park Service, Harpers Ferry, West Virginia, December 1982.

7. Harriet Chapman to W. H. Herndon, December 11, 1866, Herndon-Weik Collection, Library of Congress.

8. Letters to Herndon from John Hay, September 5, 1866 in Emanuel Hertz, The Hidden Lincoln from the Letters and Papers of William H. Herndon (New York, 1938), pp. 307-308.

9. N. W. Branson to Herndon, August 3, 1865, Herndon-Weik Collection.

10. Isaac N. Arnold (a regular visitor to Springfield, 1840-1860) was quoted in Harry E. Pratt, The Personal Finances of Abraham Lincoln (Springfield: The Abraham Lincoln Association, 1943), p. 94.

11. Eliza Leslie, Miss Leslie's Lady's House Book (Philadelphia: A. Hart, 12th edition, 1850), p. 275.

12. Geoffrey A. Godden, Encyclopaedia of British Pottery and Porcelain Marks (New York: Crown Publishing Co., 1960), p. 193.

13. Ibid., p. 667.

14. G. Bernard Hughes, Victorian Pottery and Porcelain (New York: The MacMillan Co., 1959), p. 50.

15. A. L. Bowen, "A. Lincoln; His House," Lincoln Centennial Association Papers (Springfield, privately published 1925), p. 87.

16. Harry E. Pratt, ed., "The Lincolns Go Shopping," Journal of the Illinois State Historical Society, Volume XLVIII, pp. 66-67.

17. Ibid.

18. Ibid.

19. Betty I. Madden, Arts, Crafts, and Architecture in Early Illinois (Urbana: University of Illinois Press, 1974), p. 172.
20. Bowen, Lincoln Centennial, p. 87.
21. Madden, Arts, Crafts, pp. 151, 175, 235.
22. Leslie, Miss Leslie's, p. 230.
23. Ruth Painter Randall, Mary Lincoln: Biography of a Marriage (Boston: Little Brown, 1953), pp. 102-103.
24. Leslie, Miss Leslie's, p. 230.
25. Catherine Beecher, The American Woman's Home (New York: J. B. Ford & Co., 1869), p. 371.
26. Leslie, Miss Leslie's, p. 183.
27. Madden, Arts, Crafts, p. 110.
28. Leslie, Miss Leslie's, p. 233.
29. Pratt, Journal, pp. 66-67.
30. Leslie, Miss Leslie's, p. 235.
31. Randall, Mary Lincoln, pp. 102-103.
32. Edwin C. Bearss, Historic Structure Report: Lincoln Home National Historic Site, Illinois (Denver: Denver Service Center, The National Park Service, 1973), Plate I.



33. Richard O. Cummings, The American Ice Harvests, A Historical Study in Technology, 1800-1918 (California: University of California Press, 1949), pp. 59-60.

34. Carl Sandburg, Abraham Lincoln (New York: Dell Publishing Company, Inc., 1954), Volume 1, p. 188.

35. See Winterthur, Delaware, The Henry Francis du Pont Winterthur Museum, Joseph Downs Manuscript Collection, Inventories 1840-1860.

36. See Harold L. Peterson, American Interiors: From Colonial Times to the Late Victorians (New York: Charles Scribner's Sons, 1971) and Susan Lasdun, Victorians at Home (New York: The Viking Press, 1981).

37. John Brucksch, Staff Curator, Harpers Ferry Center has purchased several mid-century photographs in their original frames with hanging attachments that indicate they were hung on the wall.

38. See Sarah Olson, "Historic Furnishing Plan: William Howard Taft National Historic Site," The National Park Service, Harpers Ferry, West Virginia, April 1, 1979, p. 106.

39. Leslie, Lady's House Book, p. 326.

40. Edwin C. Bearss, Historical Base Map: Lincoln Home National Historical Park, Illinois (Washington, D. C., Division of History, Office of Archeology and Historic Preservation, National Park Service, 1969), Plate III.



SUMMARY OF FURNISHINGS AND COST ESTIMATES

FRONT PARLOR: ROOM A\*

(See Section E, p. 165, for discussion of Recommended Furnishings)

	<u>Description</u>	<u>Source</u>	<u>Estimated Cost</u> <u>Purchase</u>	<u>Repair</u>
A.1	SOFA, ca. 1850-1860: Transitional between late Empire and Rococo style with tufted horsehair upholstery	LIHO 1060	\$ -----	\$ 100. Repair of arm
A.2- A.5	SIDE CHAIRS, four, ca. 1850-1860: Matching (of a set of six), mahogany, late Empire style, horsehair upholstery	LIHO 1116, 1117, 1118, 1119	-----	----
A.6	ARM ROCKER, ca. 1840-1860: Carved floral motif on crest rail, tufted horsehair upholstery	LIHO 19	-----	----
A.7	FOOTSTOOL, ca. 1840-1860: Turned legs, horsehair upholstery	LIHO 39	-----	----
A.8	OPEN-ARMED ROCKER, ca. 1840-1860: Padded armrests, horsehair upholstery	To be acquired	400.	----
A.9	FOOTSTOOL, ca. 1840-1860: Turned legs, horsehair upholstery	LIHO 65	-----	----
A.10	MIRROR, ca. 1850-1860: Gilt rococo pier mirror, with rounded top, 4' tall	To be acquired	450.	----

---

\*Note: All items listed are to be antiques unless otherwise noted.

FRONT PARLOR: ROOM A

	<u>Description</u>	<u>Source</u>	<u>Estimated Purchase</u>	<u>Cost Repair</u>
A.11	PIER TABLE, ca. 1850-1860: Marble topped, cabriole legs with lower shelf	LIHO 1114	\$ -----	\$ ----
A.12	WHATNOT, ca. 1850-1860: Corner whatnot with 5 shelves, and scrollwork decoration	LIHO 18	-----	----
A.13	WHATNOT, ca. 1850-1860: 5 shelves, spool turned supports, and machine-cut decoration	LIHO 24	-----	----
A.14	PARLOR STOVE, ca. 1855-1860: Gothic style on cabriole legs	LIHO 174	-----	----
A.15	STOVE IMPLEMENTS, ca. 1850- 1860: To include: shovel, tongs, hearth brush and stand, iron, brass, and wood	To be acquired	500.	----
A.16	OVAL PICTURE, ca. 1840-1860: Floral subject matter, hung from ceiling with picture cord and tassels, wax or hair	LIHO 168	-----	----
A.17	PRINTS, PAIR, ca. 1842-1850: Of George and Martha Washing- ton in oval gilt frames, hung from ceiling height with pic- ture cord and tassels	LIHO 169, 170	-----	400. Remat & repair frames
A.18	PICTURES, three, in oval frames, ca. 1840-1860: Matching frames (if possi- ble), hung from nails, no cord showing.	To be acquired	600.	----

FRONT PARLOR: ROOM A

	<u>Description</u>	<u>Source</u>	<u>Estimated Purchase</u>	<u>Cost Repair</u>
A.19	GIRANDOLE, ca. 1840-1860: Two single-arm candlesticks and one three-branch can- dlestick with glass prisms	LIHO 150, 151, 152	\$ -----	\$ 200.
A.20	CHINA PITCHERS, pair, ca. 1850-1860: Two matching French ceramic pitchers with hand-painted scenes	LIHO 148, 149	-----	----
A.21	BASKET, ca. 1840-1860: China with flower arrange- ment	To be acquired	250.	----
A.22	VASE, ca. 1840-1860: Tall cut glass	To be acquired	250.	----
A.23	DECANTER, ca. 1840-1860: Glass	To be acquired	150.	----
A.24	SMALL ORNAMENTS, two, ca. 1840-1860: Glass or china	To be acquired	150.	----
A.25	GLASS DECANTERS, two, ca. 1840-1860: Pressed or blown three-mold glass	To be acquired	450.	----
A.26	ORNAMENT, ca. 1840-1860: China	To be acquired	250.	----
A.27	DECANTERS, two, ca. 1840- 1860: Small glass decanters	LIHO 135, 136	-----	----
A.28	SMALL VASES, three, ca. 1840-1860: Glass or ceramic	LIHO 153, 696 697	-----	----
A.29	BOTTLES, two, ca. 1840-1860: Blown glass with stoppers	To be acquired	300.	----

FRONT PARLOR: ROOM A

	<u>Description</u>	<u>Source</u>	<u>Estimated Purchase</u>	<u>Cost Repair</u>
A.30	BOOKS, two, ca. 1840-1860: To have ornamental bindings	LIHO 936, 938*	\$ -----	\$ ----
A.31	ASSORTED SEASHELLS, ca. 1840-1860: To include a trocus	LIHO 285-292	-----	----
A.32	ORNAMENTS, two, ca. 1840-1860: China	To be acquired	500.	----
A.33	VOLK BUST OF LINCOLN, ca. 1860: To be a reproduction of the original	LIHO 134	-----	----
A.34	DECANTERS, four, ca. 1840-1860: Pressed or blown glass	To be acquired	800.	----
A.35	BUSTS, two, ca. 1840-1860: Parian ware	LIHO 138, 137	-----	----
A.36	BOOKS, three, ca. 1840-1860: With ornamental leather bindings	*	-----	----
A.37	STATUETTE, one, ca. 1840-1860: Parian ware	To be acquired	75.	----
A.38	VASE, ca. 1840-1860: Ceramic, double-handled	To be acquired	100.	----
A.39	SET OF FIVE BOOKS, ca. 1840-1860: Matching, with ornamental bindings	To be acquired	125.	----
A.40	BOOKS, four, ca. 1840-1860: Oversized with ornamental bindings	To be acquired	100.	----

\*Books from LIHO Collection to be used and rotated.

FRONT PARLOR: ROOM A

	<u>Description</u>	<u>Source</u>	<u>Estimated Purchase</u>	<u>Cost Repair</u>
A.41	DECANTER, ca. 1840-1860: Blown or pressed glass	LIHO 161	\$ -----	\$ ----
A.42	BRUSSELS CARPET, ca. 1850-1860: Reproduction similar to <u>Leslie's</u> illustration, wall-to-wall	To be acquired (reproduction)	5,000.	----
A.43	HEARTH RUG, one, and AREA RUG, one, ca. 1850-1860: Hooked, yarn sewn, or pieces of matching Brussels	To be acquired	3,500.	----
A.44	WALLPAPER, ca. 1850-1860: Reproduction similar to <u>Leslie's</u> illustration	To be acquired (reproduction)	3,000.	----
A.45	WINDOW HANGINGS, ca. 1850-1860: Reproduction cloth shades and cotton damask draperies	To be acquired (reproduction)	2,000.	----
A.46	BRASS VALANCES AND TIEBACKS, ca. 1850-1860: Reproduction	To be acquired (reproduction)	800.	----
		<u>ROOM A - TOTAL:</u>	\$19,750.	\$ 700.

REAR PARLOR: ROOM B

(See Section E, p. 181, for discussion of Recommended Furnishings)

	<u>Description</u>	<u>Source</u>	<u>Estimated Purchase</u>	<u>Cost Repair</u>
B.1	SIDE TABLES, ca. 1850-1860:	LIHO 3, 4	\$ -----	\$ ----
B.2	Elizabethan style, with spool turned supports and lower shelf	(reproductions)		

REAR PARLOR: ROOM B

	<u>Description</u>	<u>Source</u>	<u>Estimated Purchase</u>	<u>Cost Repair</u>
B.3	GLOBES, pair, ca. 1850-	LIHO 1, 2	\$ -----	\$ ----
B.4	1860: Celestial and terrestrial, resting in short turned stands			
B.5	SIDE CHAIRS, ca. 1850-1860:	LIHO 1120, 1121	-----	----
B.6	Two of a set of six, matching those in the front parlor, horsehair upholstery			
B.7	SOFA, ca. 1850-1860: Transitional style between Empire and Rococo, serpentine back, tufted black horsehair upholstery	LIHO 1059	-----	400.
B.8	SECRETARY-DESK, ca. 1840-1860: Large desk and bookcase with glass fronted doors, 6 shelves, fold-out desk top and paneled doors enclosing shelves beneath, turned front legs and bracket rear legs	LIHO 6	-----	100. Restore desk top cover
B.9	TABLE, ca. 1840-1860: Round mahogany veneered or walnut center table with pedestal base	To be acquired	500.	----
B.10	GIRANDOLE, ca. 1850-1860: 2 single-arm candlesticks and 1 three-branch candlestick with prisms	LIHO 378-380	-----	----
B.11	PITCHERS, pair, ca. 1850-	To be acquired	300.	----
B.12	1860: French or English porcelain with painted decoration			



REAR PARLOR: ROOM B

	<u>Description</u>	<u>Source</u>	<u>Estimated Purchase</u>	<u>Cost Repair</u>
B.13	BRUSSELS CARPET, ca. 1850-1860: Reproduction to match front parlor, wall-to-wall	To be acquired (reproduction)	\$ 3,000.	\$ ----
B.14	HEARTH RUG, ca. 1850-1860: Hooked or yarn sewn, or piece of matching Brussels	To be acquired	2,000.	----
B.15	WALLPAPER, ca. 1850-1860: Reproduction to match front parlor	To be acquired (reproduction)	3,000.	----
B.16	WINDOW HANGINGS, ca. 1850-1860: Reproduction cloth shades and cotton damask draperies to match front parlor	To be acquired (reproduction)	1,500.	----
B.17	BRASS VALANCES AND TIEBACKS, ca. 1850-1860: To match front parlor	To be acquired (reproduction)	400.	----
			-----	-----
		<u>ROOM B - TOTAL:</u>	\$10,300.	\$ 500.

SITTING ROOM: ROOM C

(See Section E, p. 187, for discussion of Recommended Furnishings)

	<u>Description</u>	<u>Source</u>	<u>Estimated Purchase</u>	<u>Cost Repair</u>
C.1	ROCKING CHAIRS, pair, ca. 1850-1860: Cane-seated, Cottage style, LIHO 45 appropriate until reproductions or antiques acquired	To be acquired (reproduction)	\$ 2,000.	\$ ----

SITTING ROOM: ROOM C

	<u>Description</u>	<u>Source</u>	Estimated Cost	
			<u>Purchase</u>	<u>Repair</u>
C.3- C.5	SIDE CHAIRS, set of three, ca. 1850-1860: Cane or up- holstered seat, flat-sided cabriole front legs, carved crest rails and s-curved back	LIHO 41, 42, 53	\$ -----	\$ ----
C.6	LARGE TABLE, ca. 1850-1860: Oval walnut table with cabriole legs and scroll or claw-and-ball feet	LIHO 40	-----	----
C.7	TABLE COVER, ca. 1850-1860: Rectangular, made of sten- ciled wool felt	To be acquired (antique or reproduction)	250.	
C.8	SEWING TABLE, ca. 1850-1860: Two-drawer pedestal stand on rectangular base with feet	LIHO 1123	-----	----
C.9	IRONWORK FLOWER STAND, ca. 1850-1860: Wire basket with handles mounted on trestle style wire supports	To be acquired (antique or reproduction)	500.	----
C.10	PAINTING OR PRINT, ca. 1840- 1860: Large picture with horse subject in gilt frame (2' x 3')	LIHO 282	-----	----
C.11	MIRROR, ca. 1840-1860: In gilt frame (3 1/2' x 1 1/2')	LIHO 1115	-----	----
C.12	GIRANDOLE SET, ca. 1840- 1860: One five-arm candle- holder and 2 single-arm candleholders with hanging prisms	LIHO 263, 264, 268	-----	100.

SITTING ROOM: ROOM C

	<u>Description</u>	<u>Source</u>	<u>Estimated Purchase</u>	<u>Cost Repair</u>
C.13	VASES, pair, ca. 1840-1860: Double handled on bases, French or English china	To be acquired	\$ 500.	\$ ----
C.14	CANDLEHOLDER, ca. 1840-1860: In the shape of a glass bottle or narrow vase	To be acquired	250.	----
C.15	DECANTERS, pair, ca. 1840-1860: Plain glass with stoppers, one with sloping shoulders, one with flat top	To be acquired	300.	----
C.16	BASKET OF APPLES, ca. 1840-1860: Wicker basket filled with artificial apples	To be acquired (reproduction)	100.	----
C.17	SPITTOONS, pair, ca. 1850-1860: Pewter, brass, or ceramic (not necessary that they match)	To be acquired	300.	----
C.18	STEREOSCOPE, ca. 1850-1860: Marked "A. Beckars, Patent April 7, 1857, Jas. Lee, N.Y. manufacturer."	LIHO 273	-----	----
C.19	INGRAIN CARPET, ca. 1850-1860: Reproduction similar to <u>Leslie's</u> illustration	To be acquired (reproduction)	3,000.	----
C.20	HEARTH RUG, ca. 1850-1860: Hooked	To be acquired	2,000.	----
C.21	WALLPAPER, ca. 1850-1860: Reproduction similar to <u>Leslie's</u> illustration	To be acquired (reproduction)	3,000.	----

SITTING ROOM: ROOM C

<u>Description</u>	<u>Source</u>	<u>Estimated Purchase</u>	<u>Cost Repair</u>
C.22 WINDOW HANGINGS, ca. 1850- Reproduction cloth shades and cotton damask draperies	To be acquired (reproduction)	\$ 2,000.	\$ ----
C.23 BRASS CORNICES, four, and TIEBACKS, four pairs, ca. 1850-1860: Reproductions similar to the <u>Leslie's</u> illustration	To be acquired (reproduction)	800.	----
		-----	-----
	<u>ROOM C - TOTAL:</u>	\$15,000.	\$ 100.

DINING ROOM: ROOM D

(See Section E, p. 197, for discussion of Recommended Furnishings)

<u>Description</u>	<u>Source</u>	<u>Estimated Purchase</u>	<u>Cost Repair</u>
D.1 TABLE, ca. 1840-1860: Drop-leaf, walnut, Cottage style	LIHO 25	\$ -----	\$ ----
D.2- CHAIRS, eight, ca. 1840- D.9 1850: Set of eight fancy chairs with rush seats and stenciled crest rails	LIHO 59, 66, 77, 79, 92, 98, 1061, 1190	-----	----
D.10 SERVING TABLE, ca. 1840- 1860: Late Empire style, with pedestal base, card table to be used as a serving table	LIHO 29	-----	----
D.11 SIDEBOARD, ca. 1840-1860: Cottage style, cherry or walnut of local manufacture	LIHO 33	-----	----

DINING ROOM: ROOM D

<u>Description</u>	<u>Source</u>	<u>Estimated Purchase</u>	<u>Cost Repair</u>
D.12 FRAMED PRINT, large, ca. 1840-1860: With a hunting scene subject	LIHO 180	\$ -----	\$ -----
D.13 FRAMED PRINT, large, ca. 1840-1860: With a hunting scene or still life subject	To be acquired	500.	----
D.14 TABLE LINENS, ca. 1840-1860: To include one linen and one cotton tablecloth, six linen and six cotton napkins, one crumb cloth	To be acquired (antique or reproduction)	500.	----
D.15 CHINA, ca. 1840-1860: Four place settings and two serving dishes, blue transfer printed ware, and assorted ironstone and creamware, ca. 1840-1860	LIHO 1019-1028, 192, 193, 195, 197	-----	----
D.16 CHINA, ca. 1840-1860: Two blue transferware dinner plates, to match LIHO 1019, 1020-1028, and one serving piece to complete a table setting for six and/or six dinner plates and several serving pieces of white ironstone	To be acquired	1,500.	----
D.17 TEA SERVICE AND TRAY, ca. 1840-1850: To include six cups and saucers, teapot, coffeepot, sugar bowl, creamer, slop bowl of transfer printed staffordshire or white ironstone, a japanned tin tray, and hot water urn	To be acquired	2,500.	----

DINING ROOM: ROOM D

	<u>Description</u>	<u>Source</u>	Estimated Cost	
			<u>Purchase</u>	<u>Repair</u>
D.18	GLASSWARE, ca. 1840-1860: Four pressed glass goblets	LIHO 1013-1016	\$ -----	\$ ----
D.19	GLASSWARE, ca. 1840-1860: Two pressed glass goblets to match (if possible D.18)	To be acquired	120.	----
D.20	FLATWARE, ca. 1840-1860: Coin silver, four place settings	LIHO 1029-1040	-----	----
D.21	FLATWARE, ca. 1840-1860: Coin silver, two place settings	To be acquired	300.	----
D.22	CAKE STAND, ca. 1840-1860: Pressed glass	LIHO 255	-----	----
D.23	CASTOR SET, ca. 1840-1860: Silver-plated or Brittania ware with glass condiment bottles	LIHO 183-189	-----	----
D.24	INGRAIN CARPET, ca. 1850- 1860: In dark colors	To be acquired (reproduction)	3,000.	----
D.25	WALLPAPER, ca. 1850-1860: Similar to paper shown in 1865 stereoscope view	To be acquired (reproduction)	2,000.	----
D.26	WINDOW HANGINGS, ca. 1850- 1860: Reproduction cloth shades and cotton damask draperies	To be acquired (reproduction)	1,000.	----
D.27	BRASS VALANCES AND TIEBACKS, ca. 1840-1860: Reproductions similar to Sitting Room	To be acquired (reproduction)	200.	----
			-----	-----
		<u>ROOM D - TOTAL:</u>	\$11,620.	\$ ----

KITCHEN-PORCH-STOREROOM: ROOMS E  
 (See Section E, p. 208, for discussion of Recommended Furnishings)

	<u>Description</u>	<u>Source</u>	<u>Estimated Purchase</u>	<u>Cost Repair</u>
<u>Kitchen</u>				
E.1	COOK STOVE, ca. 1850-1860: Cast iron Royal Oak	LIHO 559	\$ -----	\$ ----
E.2	STOVE IMPLEMENTS, ca. 1850-1860: To include shovel, tongs, and hearth brush, iron and wood	To be acquired	250.	----
E.3	HEAT SHIELD, ca. 1850-1860: square, tin or zinc	LIHO, not numbered (reproduction)	-----	----
E.4	WORK TABLE, ca. 1840-1850: Scrubbed top, tapered or turned legs, one drawer	LIHO 125	-----	----
E.5	SIDE CHAIR, ca. 1840-1850: Painted with rush seats	LIHO 1062	-----	----
E.6	DRY SINK, ca. 1840-1850: Recessed top, cupboard below	LIHO 118	-----	----
E.7	FLOOR CLOTH, ca. 1840-1850: Large square of oilcloth	To be acquired (reproduction)	5,000.	----
E.8	CUPBOARD, ca. 1840-1850: Large with shelves and doors above and below, Illinois-made	LIHO 117	-----	----
E.9	ROCKING CHAIR, ca. 1840-1850: Ladder-back with splint weave seat	LIHO 126	-----	----

KITCHEN-PORCH-STOREROOM: ROOMS E

	<u>Description</u>	<u>Source</u>	<u>Estimated Purchase</u>	<u>Cost Repair</u>
<u>Kitchen</u>				
E.10	BUTTER CHURN, ca. 1840-1850: Stoneware, made in Illinois, LIHO 480 may be used until an earlier one can be acquired	To be acquired	\$ 300.	\$ ----
E.11	OPEN SHELVES, ca. 1850-1860: Two sets of hanging wall shelves, wood	LIHO 548, 549	-----	----
E.12	COFFEE GRINDER, ca. 1850-1860: Grinder with crank handle	LIHO 578	-----	----
E.13	KNIFE CLEANING BOX, ca. 1850-1860: Wooden knife cleaner and sharpener	LIHO 495	-----	----
E.14	SPICE CABINET, ca. 1850-1860: Small wooden cabinet with eight drawers for spices	LIHO 507	-----	----
E.15	SALT BOX, ca. 1850-1860: Small, hanging, wooden salt container	LIHO 504	-----	----
E.16	BROOM, ca. 1850-1860: Broom with hickory handle	LIHO 506	-----	----
E.17	LAMPS, two, ca. 1840-1860: Small whale oil or lard lamps, blown glass or pewter	To be acquired	500.	----



KITCHEN-PORCH-STOREROOM: ROOMS E

	<u>Description</u>	<u>Source</u>	<u>Estimated Purchase</u>	<u>Cost Repair</u>
<u>Kitchen</u>				
E.18	CANDLEHOLDERS, two, ca. 1840-1860: Iron or tin	To be acquired	\$ 200.	\$ ----
E.19	LANTERN, ca. 1840-1860: Glass and tin with carrying handle	LIHO 502	-----	----
E.20	WALL BRACKET, ca. 1840- 1860: Small wooden shelf	To be acquired	50.	----
E.21	CANDLEBOX, ca. 1840-1860: Tin, plain or with punched decoration	To be acquired	100.	----
E.22	UTENSILS, ca. 1840-1850: To include a variety of kitchen utensils, (see pp. 222-226 for list of those items in the LIHO collection which are ap- propriate and for a list of those items which could be acquired), to include a tin coffeepot, two wooden tubs, one wooden bucket, one egg beater, and several baking pans	To be acquired	1,000.	----
E.23	CURTAINS, ca. 1840-1860: Two pair, calico or check cloth, simple wood rods, on brackets	To be acquired	100.	----
<u>Porch</u>				
E.24	WOOD BOX, ca. 1840-1850: Chest-type with hinged lid	To be acquired (reproduction)	200.	----

KITCHEN-PORCH-STOREROOM: ROOMS E

	<u>Description</u>	<u>Source</u>	<u>Estimated Purchase</u>	<u>Cost Repair</u>
<u>Storeroom</u>				
E.25	ICEBOX, ca. 1840-1850: Insulated box with tin lining	To be acquired	\$ 1,000.	\$ ----
E.26	PIE SAFE, ca. 1840-1850: About 5' x 3' with punched tin in sides and doors	To be acquired	1,000.	----
E.27	LAUNDRY SUPPLIES, ca. 1840-1850	To be acquired	500.	----
			-----	-----
		<u>ROOMS E - TOTAL:</u>	\$10,200.	\$ ----

FIRST FLOOR HALL: ROOM F

(See Section E, p. 230, for discussion of Recommended Furnishings)

	<u>Description</u>	<u>Source</u>	<u>Estimated Purchase</u>	<u>Cost Repair</u>
F.1	HALL STAND, ca. 1850-1860: Gothic style with small mirror, umbrella holder, and hat pegs	LIHO 51	\$ -----	\$ ----
F.2	PRINTS, two, ca. 1850-1860: Religious or romantic subjects in period frames	To be acquired	400.	----
F.3	HALL CHAIR, ca. 1850-1860: Gothic style with upholstered seat	To be acquired	400.	----
F.4	UMBRELLA, ca. 1850-1860: Bone or wooden handled. black cloth	LIHO, not numbered	-----	----

FIRST FLOOR HALL: ROOM F

	<u>Description</u>	<u>Source</u>	<u>Estimated Purchase</u>	<u>Cost Repair</u>
F.5	CANES, two, ca. 1850-1860: Wooden walking sticks	To be acquired	\$ 200.	\$ ----
F.6	WALL LAMP, ca. 1850-1860: Glass oil lamp in cast- iron bracket	To be acquired	350.	----
F.7	BRUSSELS CARPET, ca. 1850- 1860: Reproduction in a period design, different from other first floor carpet designs	To be acquired (reproduction)	2,000.	----
F.8	WALLPAPER, ca. 1850-1860: Reproduction in a period design such as a geometric pattern	To be acquired (reproduction)	2,000.	----
		<u>ROOM F - TOTAL:</u>	<u>\$ 5,350.</u>	<u>\$ ----</u>

MR. LINCOLN'S BEDROOM: ROOM G

(See Section E, p. 243, for discussion of Recommended Furnishings)

	<u>Description</u>	<u>Source</u>	<u>Estimated Purchase</u>	<u>Cost Repair</u>
G.1	BEDSTEAD, ca. 1840-1860: High post, spool turned oak. LIHO 57 may be used until a more appropriate one can be acquired	To be acquired	\$ 3,000.	\$ ----
G.2	BEDDING AND BEDCLOTHES, ca. 1840-1860: To include one mattress, two feather pillows, two sheets, two pillowcases, and one bol- ster	To be acquired (antique and/or reproduction)	300.	----

MR. LINCOLN'S BEDROOM: ROOM G

	<u>Description</u>	<u>Source</u>	<u>Estimated Purchase</u>	<u>Cost Repair</u>
G.3	BEDSPREAD, ca. 1840-1860: A Marseilles quilt	LIHO 808	\$ -----	\$ ----
G.4	BOOKS, three, ca. 1840- 1860	*	-----	----
G.5	NEWSPAPERS, ca. 1840- 1860: Springfield and other assorted papers	To be acquired (reproduction)	100.	----
G.6	CANDLESTICKS, pair, ca. 1840-1860: Pressed glass	LIHO 299, 300	-----	----
G.7	RAZOR, ca. 1840-1860: Marbelized handle and case	LIHO 341	-----	----
G.8	RAZORS, two, ca. 1840- 1860: Long handled	To be acquired	60.	----
G.9	RAZOR STROP, ca. 1830- 1860: Wood and leather	LIHO 1057	-----	----
G.10	MUG, ca. 1830-1860: Small shaving mug	LIHO 343	-----	----
G.11	SOAP, ca. 1830-1860: Shaving soap	To be acquired (reproduction)	5.	----
G.12	SHAVING BRUSH, ca. 1830- 1860: Wooden handle with natural bristles	To be acquired	50.	----
G.13	PATENT MODEL, ca. 1840: Wooden model	To be acquired	500.	----

\*Books from LIHO Collection to be used and rotated.

MR. LINCOLN'S BEDROOM: ROOM G

	<u>Description</u>	<u>Source</u>	<u>Estimated Purchase</u>	<u>Cost Repair</u>
G.14	SHAVING MIRROR, ca. 1840-1860: Mahogany veneered oval mirror with scroll cut decoration and shelf	LIHO 69	\$ -----	\$ ----
G.15	TOILET SET, ca. 1840-1860: To include bowl, pitcher, soap dish, and chamber pot, ironstone	To be acquired	600.	----
G.16	FOOTBATH, ca. 1840-1860: Tin	LIHO 332	-----	----
G.17	SLOP BUCKET, ca. 1840-1860: Tin	LIHO 331	-----	----
G.18	WATER CAN, ca. 1840-1860: Tin	LIHO 333	-----	----
G.19	TOWEL HORSE, ca. 1840-1860: Turned wood, of local manufacture	LIHO 68	-----	----
G.20	BUREAU, ca. 1840-1860: Late Empire style, mahogany	LIHO 1122	-----	----
G.21	WARDROBE, ca. 1840-1860: Double doors, walnut	LIHO 58	-----	----
G.22	WASHSTAND, ca. 1840-1860: With drawer and double doors below in Cottage or Elizabethan style.	LIHO 90	-----	----
G.23	SIDE CHAIRS, ca. 1840-1860: A pair in the late Empire style, cane seated	LIHO 31, 32	-----	----

## MR. LINCOLN'S BEDROOM: ROOM G

<u>Description</u>	<u>Source</u>	<u>Estimated Purchase</u>	<u>Cost Repair</u>
G.24 TABLE, ca. 1840-1860: Small rectangular table or round pedestal table	To be acquired	\$ 250.	\$ ----
G.25 TABLE COVER, ca. 1840-1860: Green baize, 3'6" x 4' or 3'6" in diameter	To be acquired (reproduction)	100.	----
G.26 MIRROR, ca. 1840-1860: Wood, veneered, ogee molded frame, 2 1/2' x 1 1/2'	LIHO 61	-----	----
G.27 PRINTS, two, ca. 1840-1860: Subject matter should be historical or political in a pair of rectangular ogee molded frames, 18" x 12"	LIHO 325, 326	-----	----
G.28 BOOTJACK, ca. 1840-1860: Wooden with extended handle	LIHO 334	-----	----
G.29 DRESSER SCARVES, two, ca. 1840-1860: White fringed cloths	To be acquired	50.	----
G.30 LAP DESK, ca. 1840-1860: Walnut writing desk	LIHO 308	-----	----
G.31 STOVE, ca. 1840-1860: Cast-iron, wood heating stove	LIHO 330	-----	----
G.32 STAND, SHOVEL, TONGS, ca. 1850-1860: Iron and brass	LIHO 327, 328, 329	-----	----
G.33 HEARTH BRUSH, ca. 1850- 1860: Wooden hearth brush with natural bristles	To be acquired	75.	----

MR. LINCOLN'S BEDROOM: ROOM G

	<u>Description</u>	<u>Source</u>	<u>Estimated Purchase</u>	<u>Cost Repair</u>
G.34	COLLAR BOX AND COLLARS, ca. 1850-1860: Circular wooden box containing starched collars	To be acquired	\$ 100.	\$ ----
G.35	WINDOW HANGINGS, ca. 1850-1860: Cloth shades and muslin curtains	To be acquired (reproduction)	800.	----
G.36	INGRAIN CARPET, ca. 1850-1860: Reproduction ingrain	To be acquired (reproduction)	2,500.	----
G.37	WALLPAPER, ca. 1850-1860: To match original still on the wall	LIHO Collections (reproduction)	-----	----
<u>ROOM G - TOTAL:</u>			\$ 8,490.	\$ ----

GUEST ROOM: ROOM H

(See Section E, p. 257, for discussion of Recommended Furnishings)

	<u>Description</u>	<u>Source</u>	<u>Estimated Purchase</u>	<u>Cost Repair</u>
H.1	BEDSTEAD, ca. 1840-1860: Mahogany, French bedstead	LIHO 71	\$ -----	\$ ----
H.2	BUREAU AND MIRROR, ca. 1840-1850: Late Empire and mahogany veneered mirror	LIHO 60, 91	-----	----
H.4	WARDROBE, ca. 1840-1860: Large late Empire style	LIHO 76	-----	----
H.5	WASHSTAND, ca. 1840-1860: Late Empire style with enclosed lower shelf	LIHO 67	-----	----

GUEST ROOM: ROOM H

	<u>Description</u>	<u>Source</u>	<u>Estimated Purchase</u>	<u>Cost Repair</u>
H.6	ROCKING CHAIR AND FOOTSTOOL,	LIHO 64, 20	\$ -----	\$ ----
H.7	ca. 1840-1860: Cane seated rocker with upholstered or caned footstool			
H.8	PRINT, ca. 1840-1860: Litho- graph or engraving in wood frame, approximately 2' x 2 1/2'	LIHO 381	-----	----
H.9	PRINT, ca. 1840-1860: Litho- graph or engraving in wood frame, approximately 1 1/2' x 1'	To be acquired	250.	----
H.10	WASHBASIN, ca. 1840-1860: White ironstone	To be acquired	100.	----
H.11	MUG, ca. 1840-1860: White ironstone	To be acquired	150.	----
H.12	PITCHER AND SOAP DISH, ca. 1840-1860: White ironstone, painted	LIHO 384, 385	-----	----
H.13	SLOP JAR, ca. 1840-1860: Ironstone	LIHO 1056	-----	----
H.14	STOOL, ca. 1840-1860: Crude wooden stool	LIHO 48	-----	----
H.15	DRESSER SCARVES, ca. 1840- 1860: Two white cloth fringed scarves	To be acquired	50.	----
H.16	VASE, ca. 1840-1860: French or English painted ceramic	To be acquired	100.	----
H.17	WATER BOTTLE AND TUMBLER, ca. 1840-1860: Glass	To be acquired	100.	----



GUEST ROOM: ROOM H

	<u>Description</u>	<u>Source</u>	<u>Estimated Purchase</u>	<u>Cost Repair</u>
H.18	PIN CUSHION, ca. 1840-1860: Small velvet cornered pillow	To be acquired	\$ 25.	\$ ----
H.19	BEDDING AND BEDCLOTHES, ca. 1840-1860: Mattress, bolster, two feather pillows, two sheets, and two pillowcases	To be acquired (antique and/or reproduction)	200.	----
H.20	BEDSPREAD, ca. 1840-1860: Quilted cotton chintz in a historic pattern	To be acquired (reproduction)	400.	----
H.21	STOVE, ca. 1840-1860: Cast-iron heating stove	LIHO 374	-----	----
H.22	SHOVEL, TONGS, HEARTH BRUSH, ca. 1850-1860: Iron and brass with wooden herth brush	To be acquired	250.	----
H.23	SOFA, ca. 1840: Chaise with black horsehair upholstery and tufted half back	LIHO 13	-----	----
H.24	WINDOW HANGINGS, ca. 1850-1860: Reproduction cloth shades and muslin curtains	To be acquired (reproduction)	800.	----
H.25	INGRAIN CARPET, ca. 1850-1860: Reproduction	To be acquired (reproduction)	2,500.	----
H.26	WALLPAPER, ca. 1850-1860: A reproduction in a period design	To be acquired (reproduction)	2,000.	----
			-----	-----
		<u>ROOM H - TOTAL:</u>	\$ 6,925.	\$ ----

MRS. LINCOLN'S BEDROOM: ROOM I  
 (See Section E, p. 265, for discussion of Recommended Furnishings)

	<u>Description</u>	<u>Source</u>	<u>Estimated Cost</u>	
			<u>Purchase</u>	<u>Repair</u>
I.1	BEDSTEAD, ca. 1840-1860: Low post, Cottage style with turned spindles	LIHO 101	\$ -----	\$ ----
I.2	BEDDING AND BEDCLOTHES, ca. 1840-1860: Mattress, bolster, two feather pil- lows, two sheets, and two linen pillowcases	To be acquired (antique and/or reproduction)	400.	----
I.3	BEDSPREAD, ca. 1840-1860: A Marseilles quilt	LIHO 828	-----	----
I.4	BUREAU, ca. 1820-1840: Federal style, reeded pilasters and a swell front	LIHO 1126	-----	----
I.5	WOODEN BRACKETS, pair, ca. 1850-1860: Small wooden shelves with scrollwork decoration	LIHO 694, 695	-----	----
I.6	COMMODE, ca. 1840-1860: Mahogany veneered	LIHO 104	-----	----
I.7	WASHSTAND, ca. 1840-1860: Late Empire style	LIHO 106	-----	----
I.8	ROCKING CHAIR AND FOOTSTOOL, I.9 ca, 1840-1860: Walnut lady's rocker and stool, caned or upholstered in black horse- hair	LIHO 56, 96	-----	----
I.10	SEWING TABLE, ca. 1840-1860: Small pedestal stand table with two drawers	LIHO 46	-----	----

MRS. LINCOLN'S BEDROOM: ROOM I

	<u>Description</u>	<u>Source</u>	<u>Estimated Purchase</u>	<u>Cost Repair</u>
I.11	MIRROR, ca. 1840-1860: Mahogany veneered, ogee molded wooden frame	LIHO 103	\$ -----	\$ ----
I.12	BRACKETS, pair, ca. 1840- 1860: Wooden, scrollwork decoration	LIHO 727, 728	-----	----
I.13	OVAL PICTURE, ca. 1840- 1860: Wooden frame with hair, shellwork, or pressed flower subject	LIHO 706	-----	----
I.14	FRAMED PICTURES, pair, ca. 1850-1860: Photo- graphs of Tad and Willy	LIHO 392, 393	-----	----
I.15	BOWL, PITCHER, SOAP DISH, AND SLOP JAR, ca. 1840- 1860: White ironstone	To be acquired	500.	----
I.16	COLOGNE BOTTLES (two), ca. 1840-1860: Glass or French china	LIHO 722, 723	-----	----
I.17	PIN CUSHION, ca. 1840- 1860: Cloth covered cushion with pre-1860 pins	To be acquired	50.	----
I.18	DRESSER SCARVES (two), ca. 1840-1860: White cotton fringed cloths	To be acquired	50.	----
I.19	CANDLESTICKS, pair, ca. 1840-1860: Parian ware	LIHO 350, 351	-----	----
I.20	WICKER SEWING BASKET, ca. 1850-1860: Oval basket with short sides and lid	LIHO 1003	-----	----

MRS. LINCOLN'S BEDROOM: ROOM I

	<u>Description</u>	<u>Source</u>	<u>Estimated Purchase</u>	<u>Cost Repair</u>
I.21	TOWELS, ca. 1840-1860: Cotton	To be acquired	\$ 50.	\$ ----
I.22	VASE OR STATUETTE, ca. 1840-1860: English or French china	LIHO 699	-----	----
I.23	BRUSH AND COMB, ca. 1840- 1860: Wooden handled	To be acquired	100.	----
I.24	HAIR JEWELRY, ca. 1840- 1860: Woven hair ornaments	LIHO 714-718	-----	----
I.25	WOOL SHAWL, ca. 1850: Pink and yellow wool shawl	LIHO 744	-----	----
I.26	FRAMED CUTOUT PICTURES, ca. 1850-1860: People mounted on black back- ground	LIHO 729-731	-----	----
I.27	BOOKS, ca. 1830-1860: Assorted	*	-----	----
I.28	PIECE OF SEWING, unfin- ished, ca. 1850-1860: Hand sewing on linen, cotton, or wool	To be acquired (antique or reproduction)	100.	----
I.29	FOOT TUB, ca. 1860: Earthenware	LIHO 768	-----	----
I.30	WRITING BOX AND WRITING EQUIPMENT, ca. 1840-1860: Slant-top box, mahogany or walnut, pens, paper, envelopes	To be acquired	150.	----

\*Books from LIHO Collection to be used and rotated.

MRS. LINCOLN'S BEDROOM: ROOM I

	<u>Description</u>	<u>Source</u>	<u>Estimated Purchase</u>	<u>Cost Repair</u>
I.31	STOVE, ca. 1840-1860: Small parlor stove	LIHO 705	\$ -----	\$ ----
I.32	SHOVEL, TONGS, HEARTH BRUSH, ca. 1850-1860: Iron and brass and wooden hearth brush	To be acquired	250.	----
I.33	DRESSING TABLE, ca. 1840- 1860: Small table with drawers and mirror, walnut or mahogany	To be acquired	500.	----
I.34	WINDOW HANGINGS, ca.1850- 1860: Reproduction cloth shades and muslin curtains	To be acquired (reproduction)	800.	----
I.35	WALLPAPER, ca. 1850-1860: Reproduction based on a period design	To be acquired (reproduction)	2,000.	----
I.36	INGRAIN CARPET, ca. 1850- 1860	LIHO Collections	-----	----
			<hr/>	<hr/>
		<u>ROOM I - TOTAL:</u>	\$ 4,950.	\$ ----

BOYS' ROOM: ROOM J

(See Section E, p. 277, for discussion of Recommended Furnishings)

	<u>Description</u>	<u>Source</u>	<u>Estimated Purchase</u>	<u>Cost Repair</u>
J.1	BEDSTEAD, ca. 1840-1860: Low post Cottage style bedstead	LIHO 88	\$ -----	\$ ----

## BOYS' ROOM: ROOM J

	<u>Description</u>	<u>Source</u>	<u>Estimated Purchase</u>	<u>Cost Repair</u>
J.2	BEDDING AND BEDCLOTHES, ca. 1840-1860: To include mattress, bolster, two feather pillows, two sheets, and two linen pillowcases	To be acquired (antique and/or reproduction)	\$ 400.	\$ ----
J.3	BEDSPREAD, ca. 1840-1860: A coverlet or quilt	LIHO 801	-----	----
J.4	BUREAU, ca. 1840-1860: Late Empire style, walnut	LIHO 102	-----	----
J.5	SIDE CHAIR, ca. 1840-1860: Late Empire or Cottage style	LIHO 35	-----	----
J.6	WASHSTAND, ca. 1840-1860: Cottage style washstand with cutout for bowl, drawer and shelf beneath	To be acquired	400.	----
J.7	WASHBOWL, PITCHER, AND CHAMBER POT, ca. 1840-1850: Ironstone	To be acquired	400.	----
J.8	MIRROR, ca. 1840-1860: Mahogany veneered frame 2 1/2' x 1 1/2'	LIHO 84	-----	----
J.9	PRINT, ca. 1840-1860: Framed, a subject that would appeal to a small boy	To be acquired	200.	----
J.10	PRINT, ca. 1840-1860: Framed, a subject that would appeal to a small boy	To be acquired	75.	----

## BOYS' ROOM: ROOM J

	<u>Description</u>	<u>Source</u>	<u>Estimated Purchase</u>	<u>Cost Repair</u>
J.11	DRESSER SCARF, ca. 1840-1860: White rectangular fringed cloth	To be acquired	\$ 50.	\$ ----
J.12	BRUSHES AND COMBS, two, ca. 1840-1860: Wooden with natural bristles	To be acquired	100.	----
J.13	TOOTHBRUSHES, two, ca. 1840-1860: Wooden with natural bristles	To be acquired (antique or reproduction)	25.	----
J.14	BOYS' TOYS, ca. 1840-1860: Tin or wooden (soldiers, bow and arrow, marbles, train)	To be acquired	500.	----
J.15	BOYS' CLOTHING, ca. 1840-1860: To include pants, jackets, shirts, collars	To be acquired	400.	----
J.16	WALL SHELVES, ca. 1840-1860: Two-tiered shelf	LIHO 549	-----	----
J.17	TOY CHEST, ca. 1820-1860: Wooden box with lid	LIHO 87	-----	----
J.18	TABLE, ca. 1840-1860: Wooden table	LIHO 75	-----	----
J.19	WINDOW HANGINGS, ca. 1850-1860: Reproduction cloth shades and muslin curtains	To be acquired (reproduction)	800.	----
J.20	CARPET, ca. 1850-1860: Reproduction rag	To be acquired (reproduction)	1,000.	----
J.21	WALLPAPER, ca. 1850-1860: Reproduction	To be acquired (reproduction)	2,000.	----
		<u>ROOM J - TOTAL:</u>	\$ 6,350.	\$ ----

MAID'S ROOM: ROOM K

(See Section E, p. 285, for discussion of Recommended Furnishings)

	<u>Description</u>	<u>Source</u>	<u>Estimated Purchase</u>	<u>Cost Repair</u>
K.1	LOW POST BEDSTEAD, ca. 1830-1850: Painted, made of local wood (cherry, walnut, ash, or sycamore)	LIHO 113	\$ -----	\$ ----
K.2	BEDDING AND BEDCLOTHES, ca. 1840-1860: Mattress, one feather pillow, two sheets, one pillowcase, one blanket.	To be acquired (reproduction and/or antique)	200.	----
K.3	WASHSTAND, ca. 1830-1850: Cottage style, cutout top for washbowl, and lower shelf of local wood	LIHO 114	-----	----
K.4	WARDROBE, ca. 1830-1850: Plain with paneled doors, shelves, and pegs, made of local wood	LIHO 1124	-----	----
K.5	ROCKER, ca. 1830-1850: Caned seat and back	LIHO 47	-----	----
K.6	SIDE TABLE, ca. 1830-1850: Two-drawer stand from local wood	LIHO 95	-----	----
K.7	TRUNK, ca. 1830-1850: Chest on drawered stand	LIHO 97	-----	----
K.8	PRINT, ca. 1830-1850: In wood frame 1 1/2' x 2 1/2', religious subject	LIHO 749	-----	----
K.9	MIRROR, ca. 1830-1850: Small, in plain frame	LIHO 115	-----	----



MAID'S ROOM: ROOM K

	<u>Description</u>	<u>Source</u>	<u>Estimated Purchase</u>	<u>Cost Repair</u>
K.10	CHAMBER POT, SLOP JAR, ca. 1830-1850: Ironstone	LIHO 753, 754	\$ -----	\$ ----
K.11	WASHBOWL AND PITCHER, ca. 1830-1850: Ironstone	To be acquired	300.	----
K.12	COLOGNE OR PATENT MEDICINE BOTTLE, ca. 1840-1850: Molded glass	LIHO 761	-----	----
K.13	PIN CUSHION, ca. 1840-1860: Small, cloth covered cushion with pins	To be acquired	25.	----
K.14	BRUSH AND COMB, ca. 1840- 1860: Wooden comb and brush set	To be acquired	50.	----
K.15	BED WARMER PAN, ca. 1840- 1860: Brass pan with long wooden handle	LIHO 760	-----	----
K.16	WINDOW HANGINGS, ca. 1840- 1860: Cloth shades	To be acquired (reproduction)	100.	----
K.17	CARPET, ca. 1850-1860: Rag carpeting, area rug	LIHO Collections	-----	----
		<u>ROOM K - TOTAL:</u>	\$ 675.	\$ ----

SECOND FLOOR HALL: ROOM L

(See Section E, p. 292, for discussion of Recommended Furnishings)

	<u>Description</u>	<u>Source</u>	<u>Estimated Purchase</u>	<u>Cost Repair</u>
L.1	CHAIR, ca. 1860: Reproduc- tion plank bottom, bamboo turned legs painted	To be acquired (reproduction)	\$ 250.	\$ ----

SECOND FLOOR HALL: ROOM L

	<u>Description</u>	<u>Source</u>	<u>Estimated Purchase</u>	<u>Cost Repair</u>
L.2	MIRROR, ca. 1855-1860: Tall mirror, either Rococo revival or Gothic style with shelf	To be acquired	\$ 1,000.	\$ ----
L.3	STAND, ca. 1850-1860: Pedestal with round top (approximately 1' diameter)	To be acquired	500.	----
L.4	HALL CHAIR, ca. 1850-1860: In Gothic style	To be acquired	500.	----
L.5	PRINTS, ca. 1850-1860: Two in a romantic or religious subject (suitable for a Presbyterian)	To be acquired	500.	----
L.6	VASE, ca. 1850-1860: French or English porcelain, with artificial or real flowers	To be acquired	150.	----
L.7	PLANT, ca. 1850-1860: Ivy in a terra cotta pot	To be acquired (modern)	50.	----
L.8	WINDOW HANGINGS, ca. 1850-1860: Reproduction cloth shades and muslin curtains	To be acquired (reproduction)	800.	----
L.9	CARPET, ca. 1850-1860: Brussels, reproduction in a pattern similar to ingrain	To be acquired (reproduction)	2,500.	----
L.10	WALLPAPER, ca. 1850-1860: Reproduction (same as first floor hallway)	To be acquired (reproduction)	2,000.	----
			-----	-----
		<u>ROOM L - TOTAL:</u>	\$ 8,250.	\$ ----

FLOOR PLANS

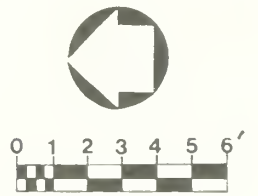
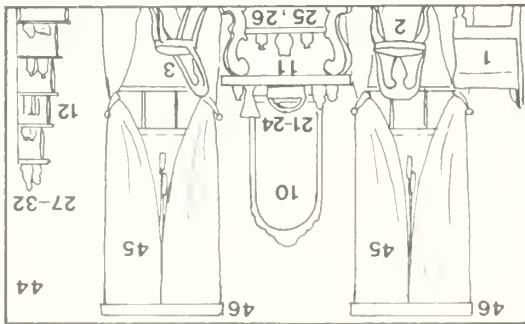
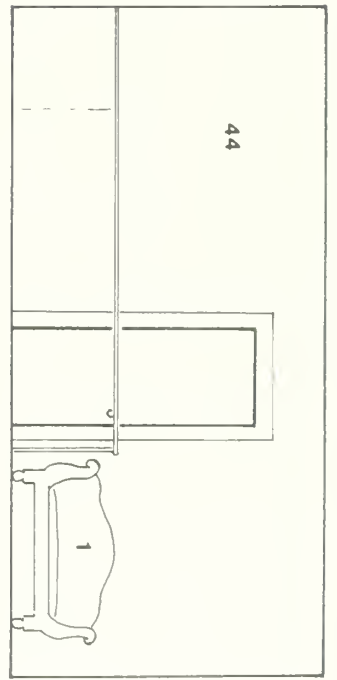
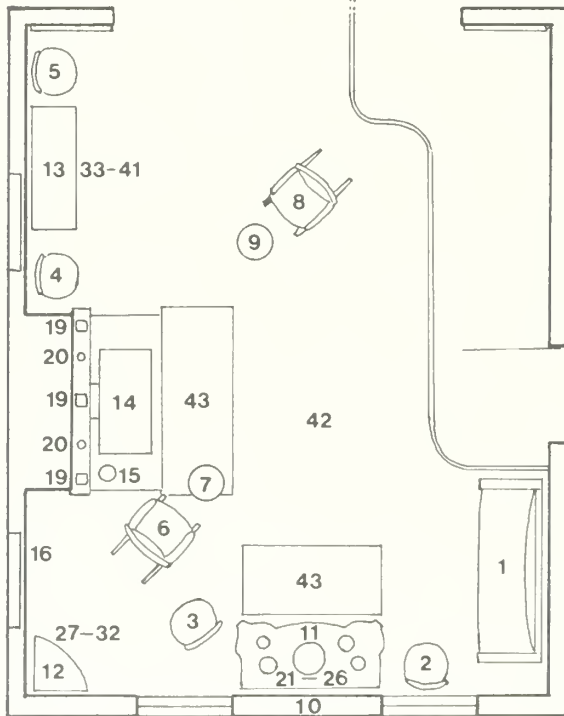
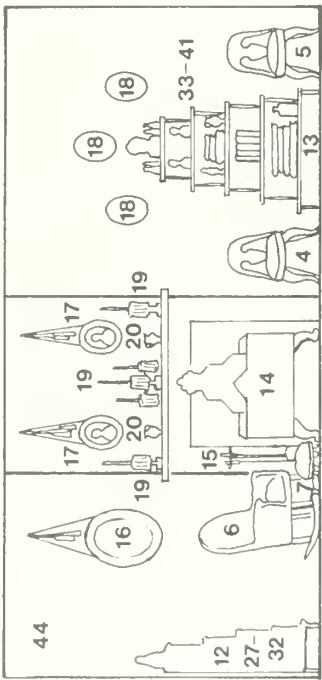
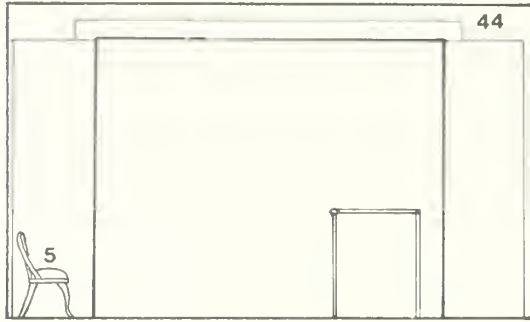

# Front Parlor

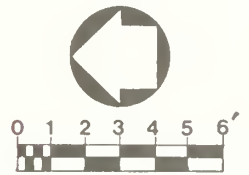
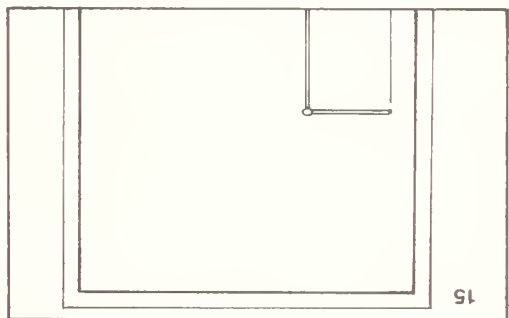
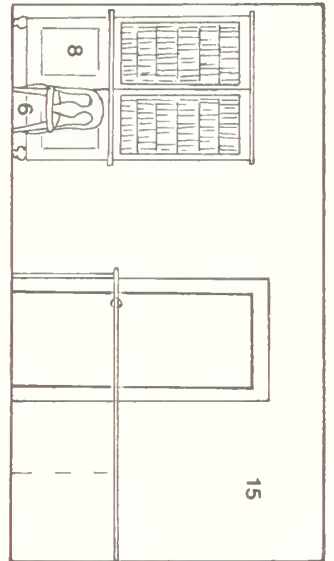
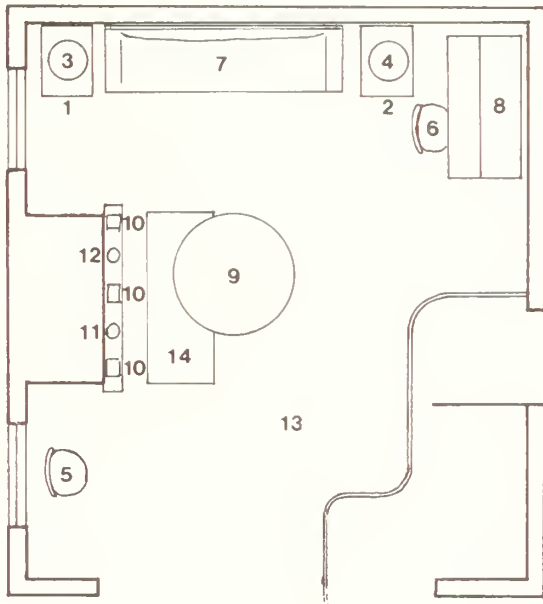
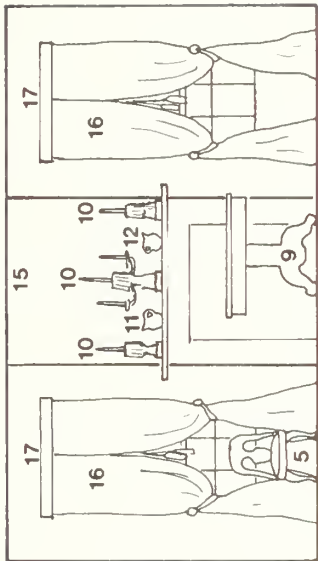
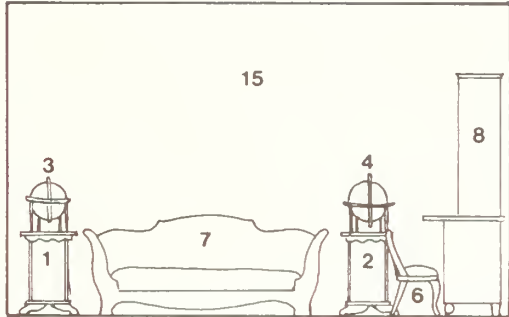

# Rear Parlor

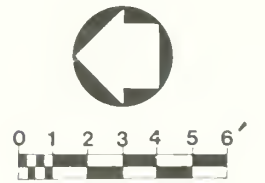
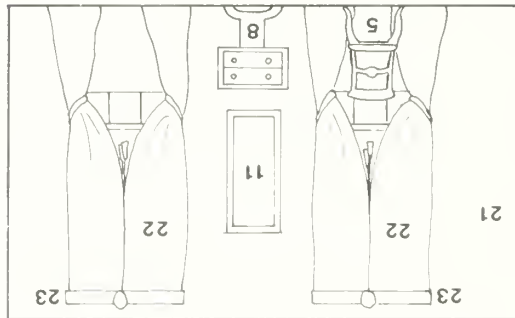
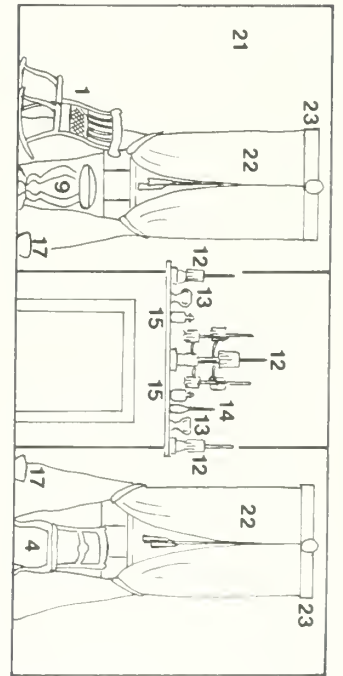
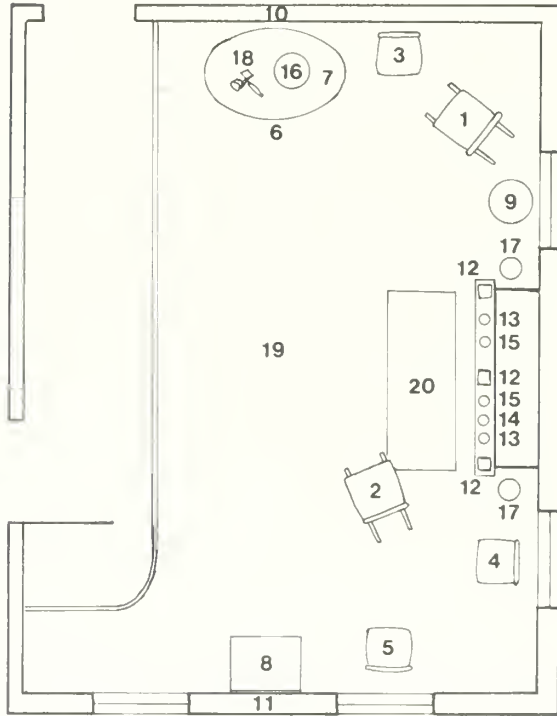
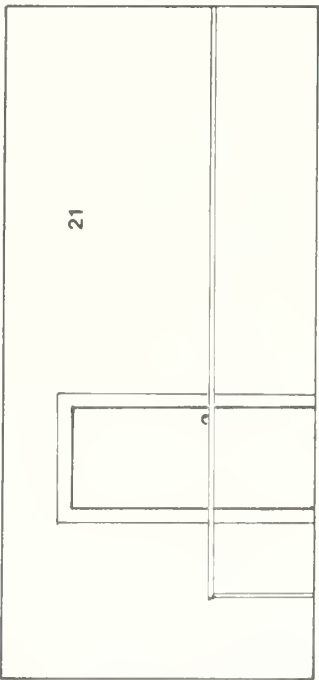
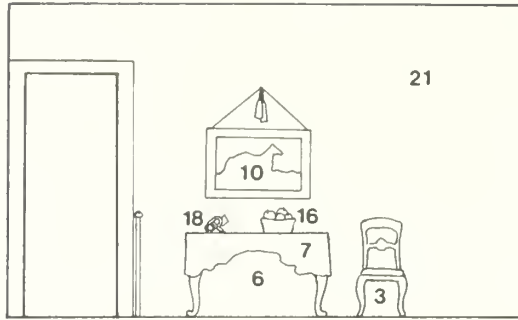

# Sitting Room

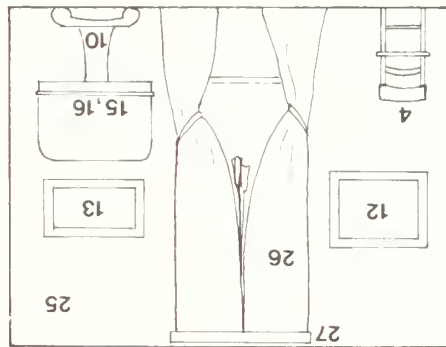
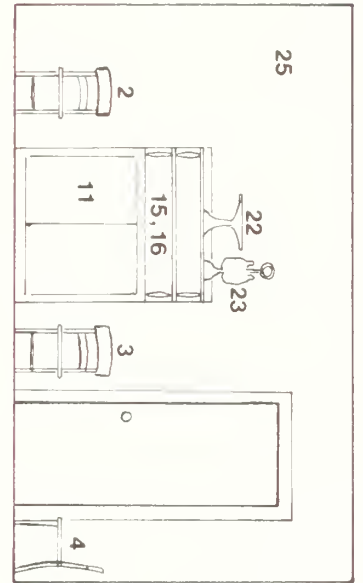
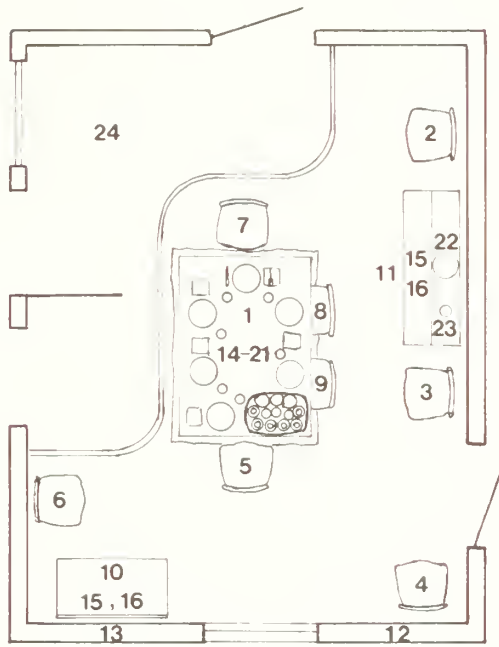
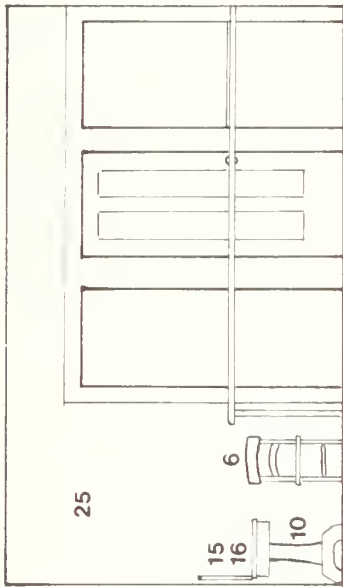
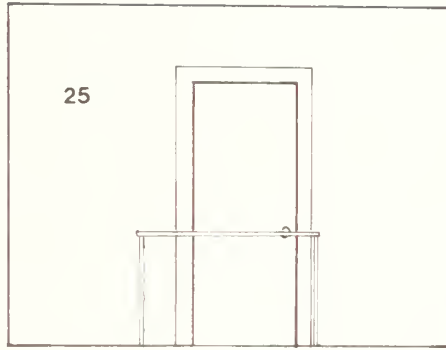

# Dining Room

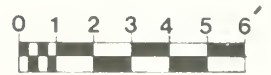
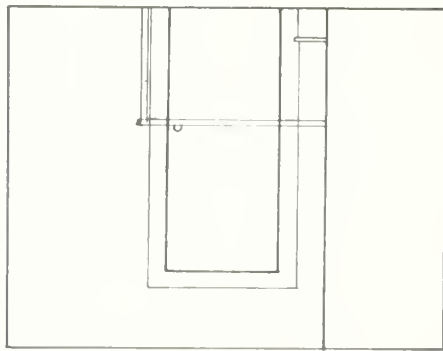
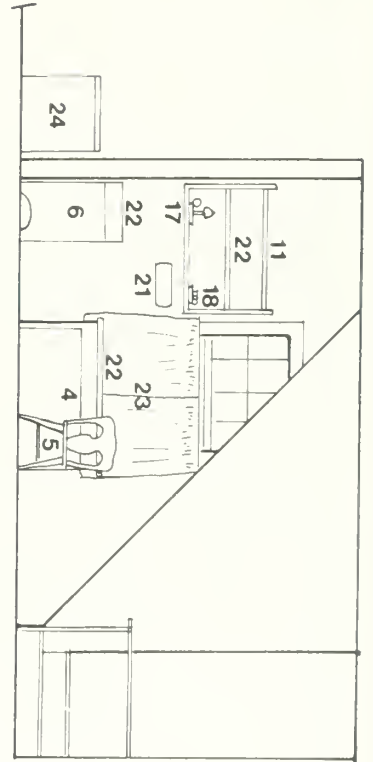
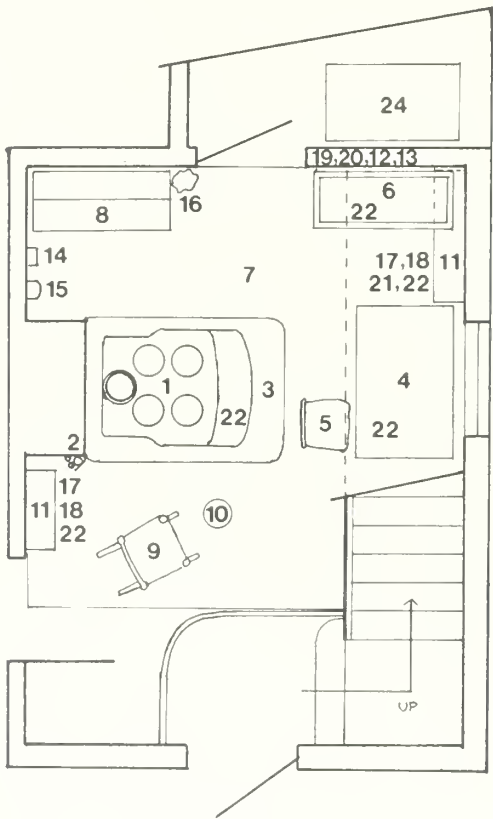
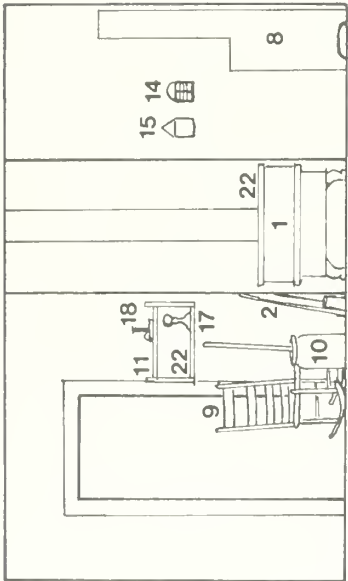
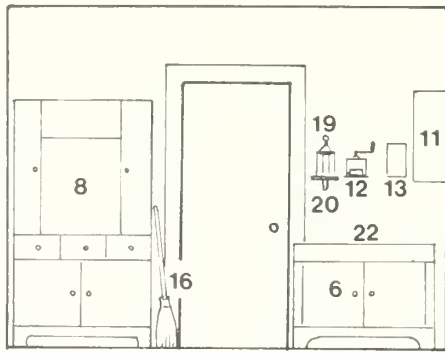

# Kitchen and Porch



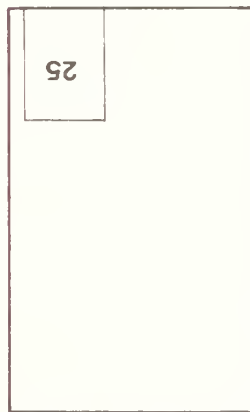
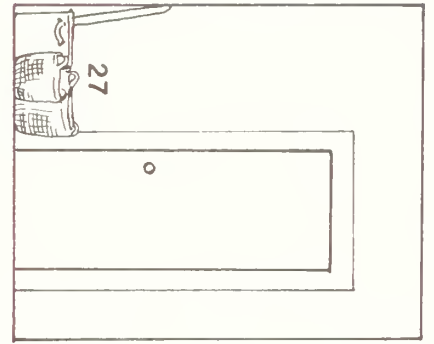
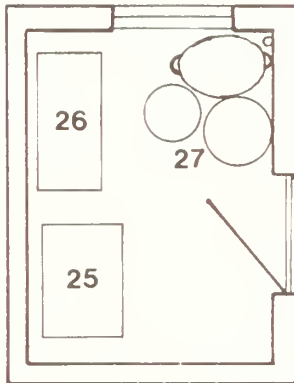
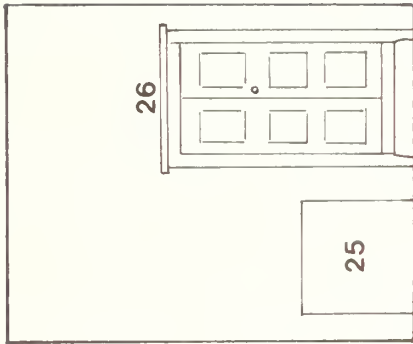
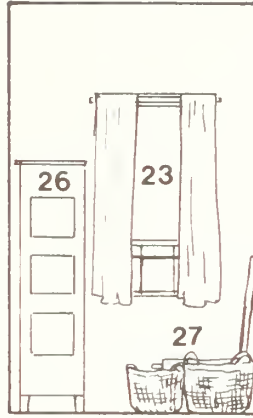

# Storeroom

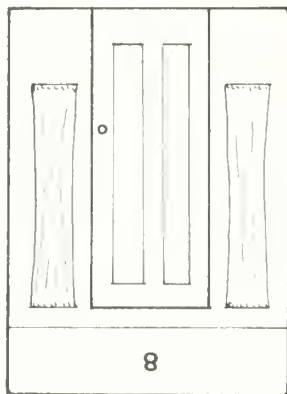
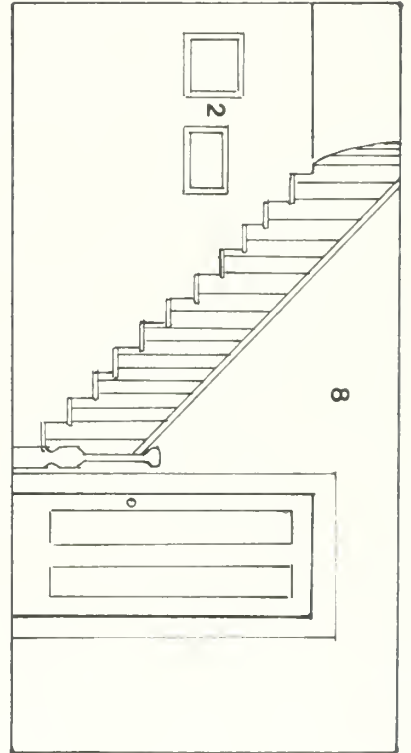
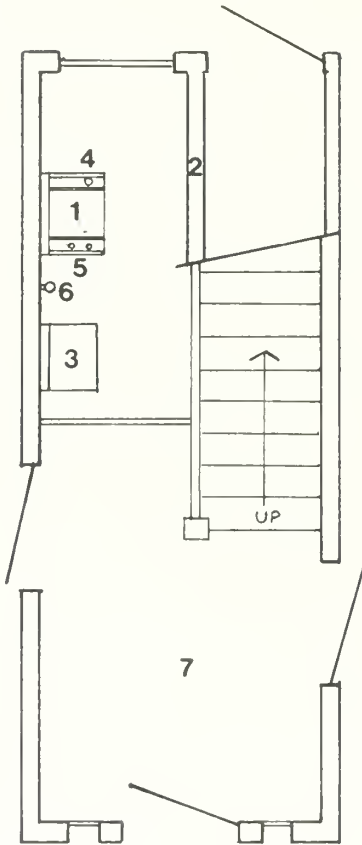
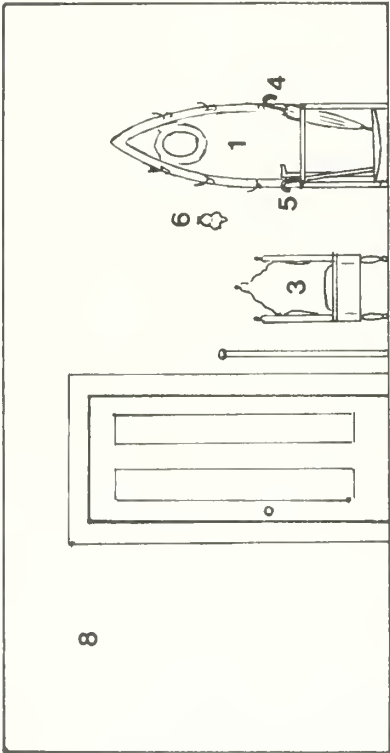
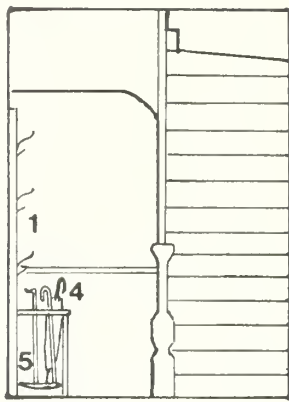

# First Floor Hall

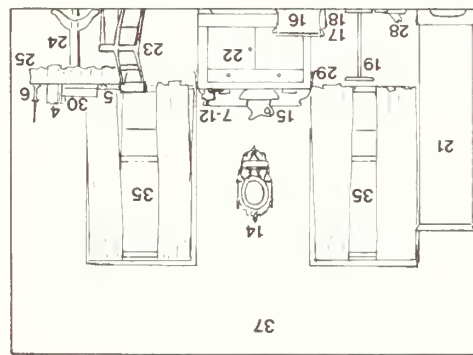
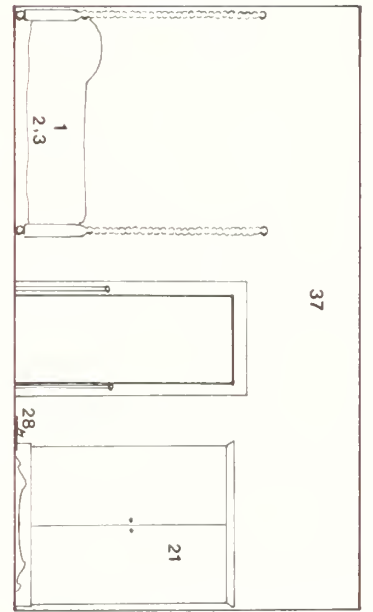
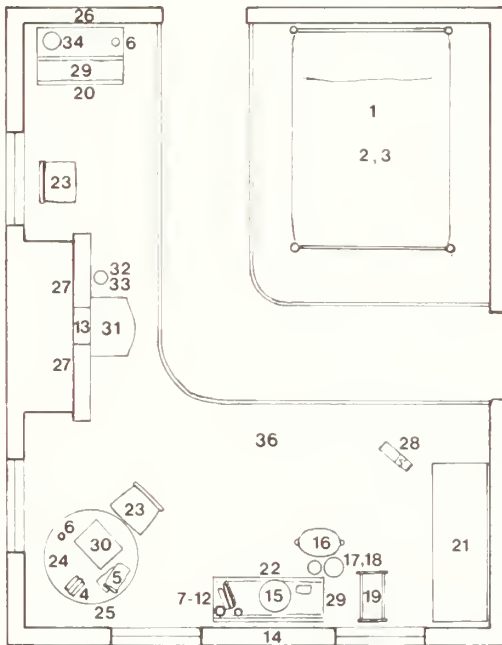
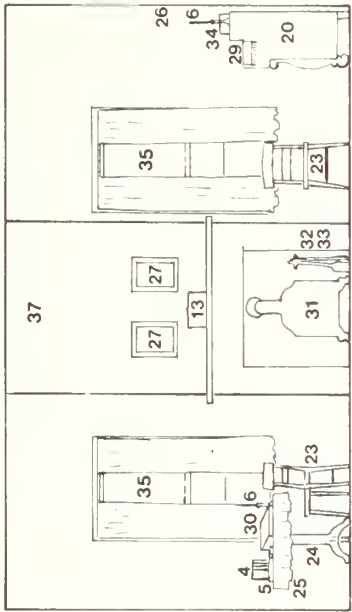
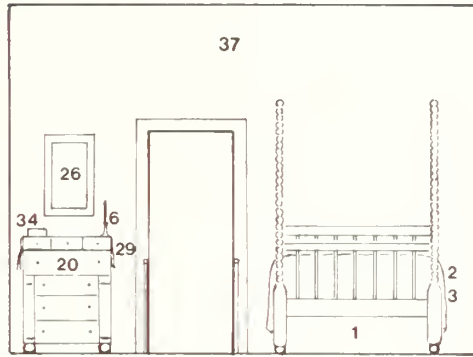

# Mr. Lincoln's Bedroom

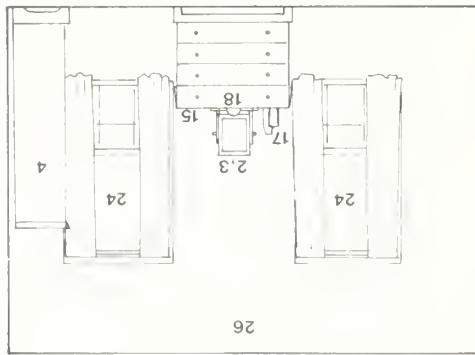
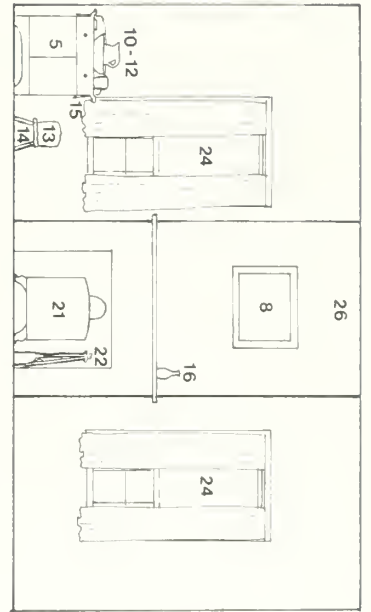
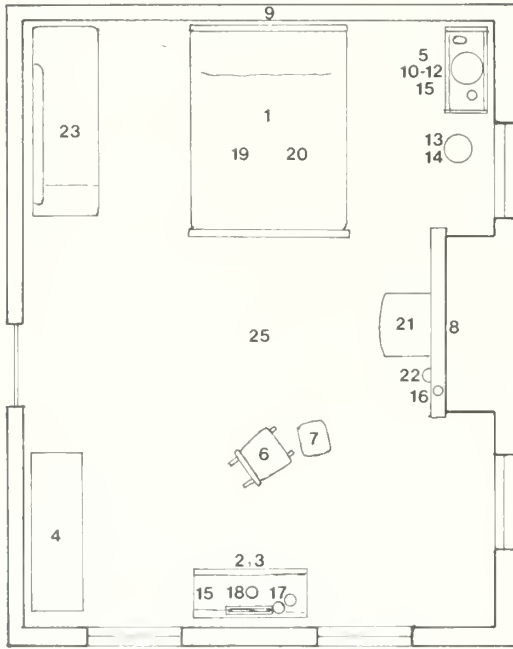
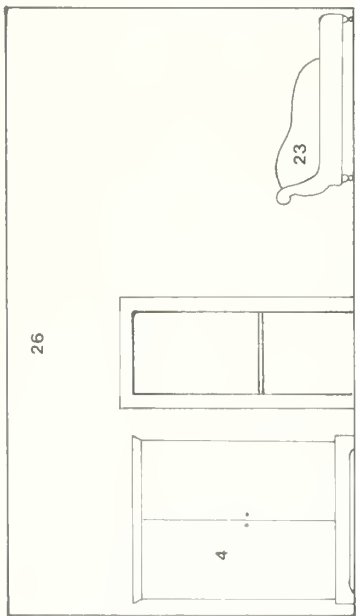
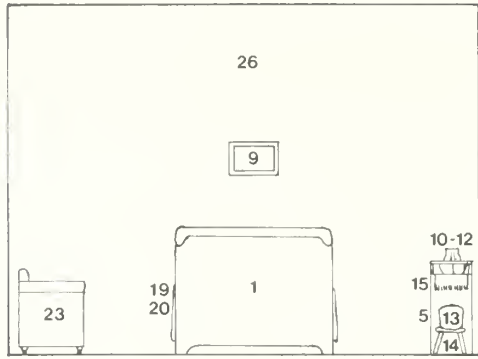

# Guest Bedroom

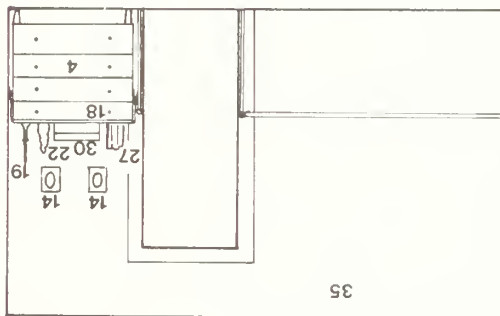
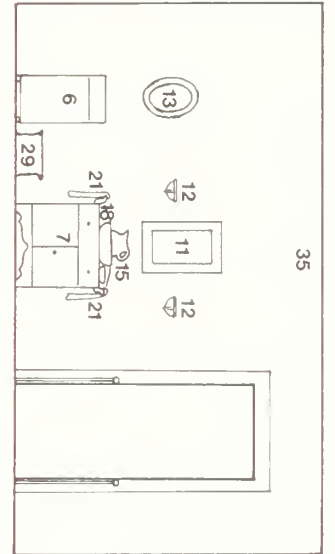
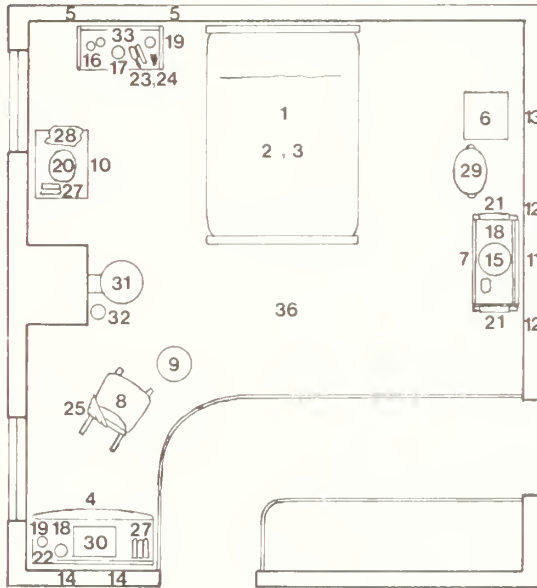
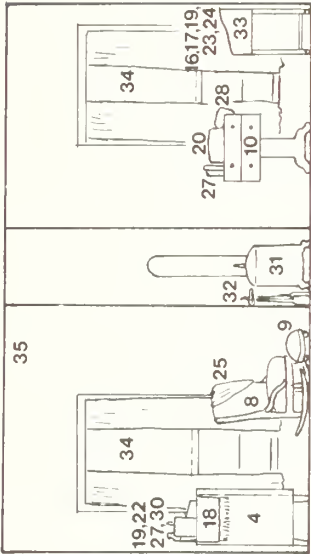
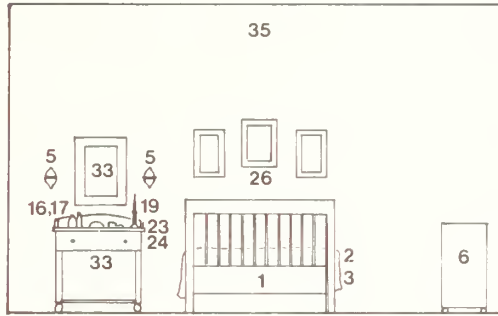

# Mrs. Lincoln's Bedroom

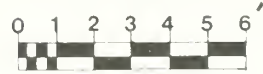
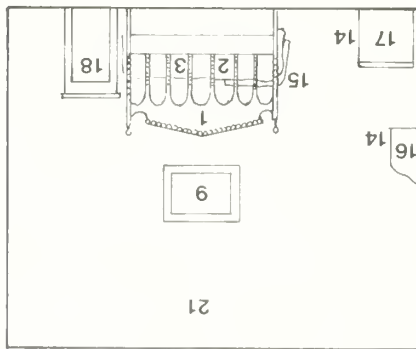
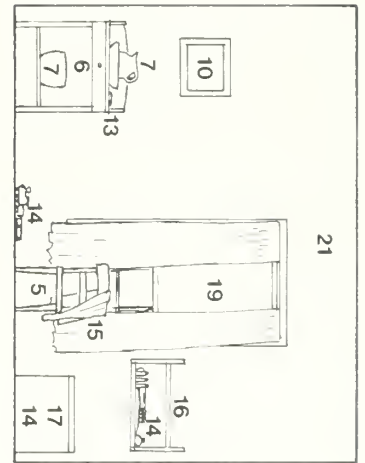
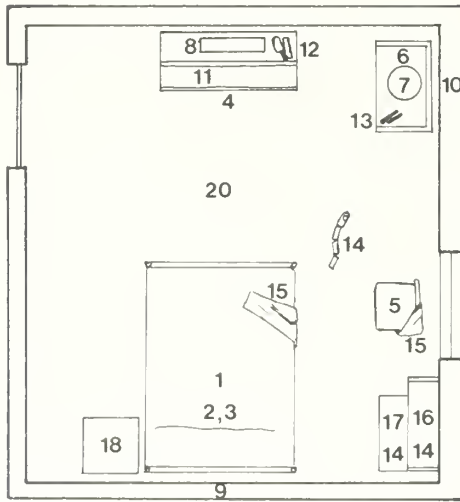
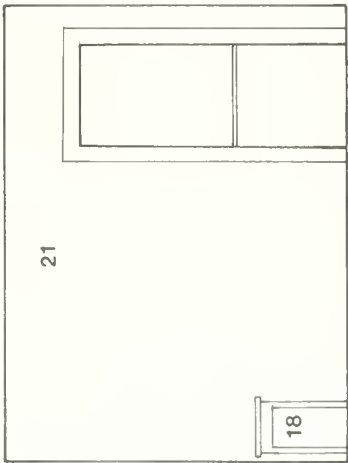
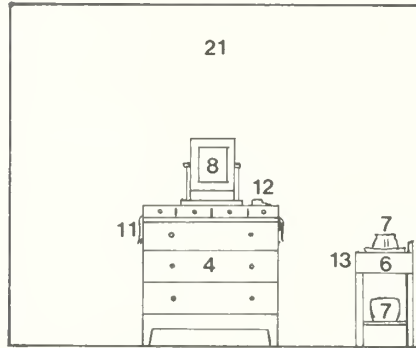

# Boy's Room

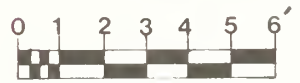
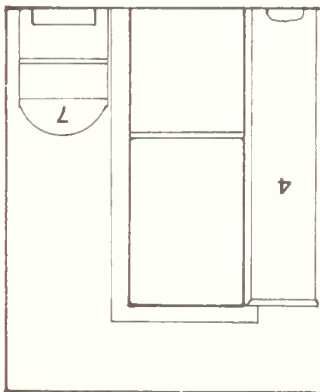
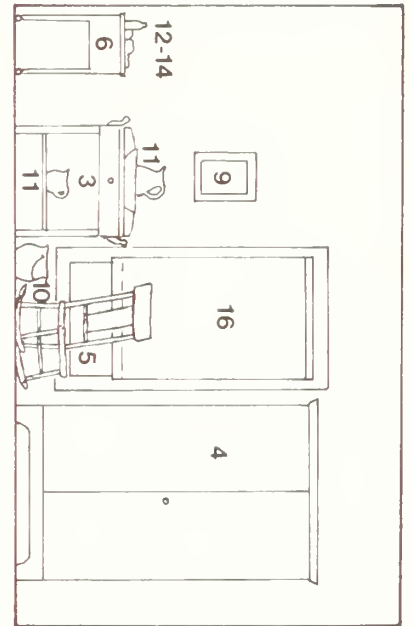
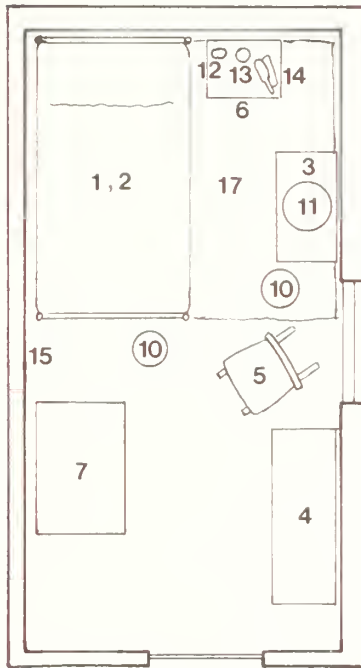
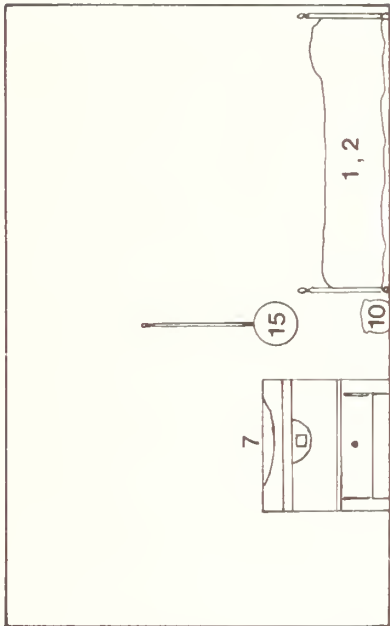
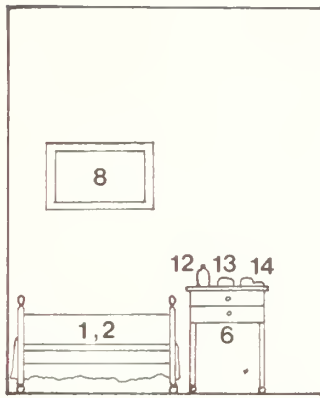

# Maid's Room

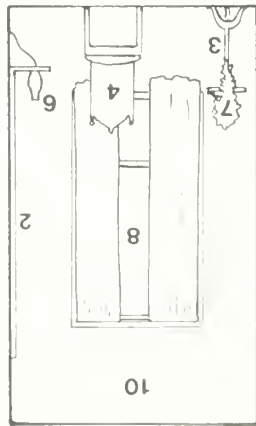
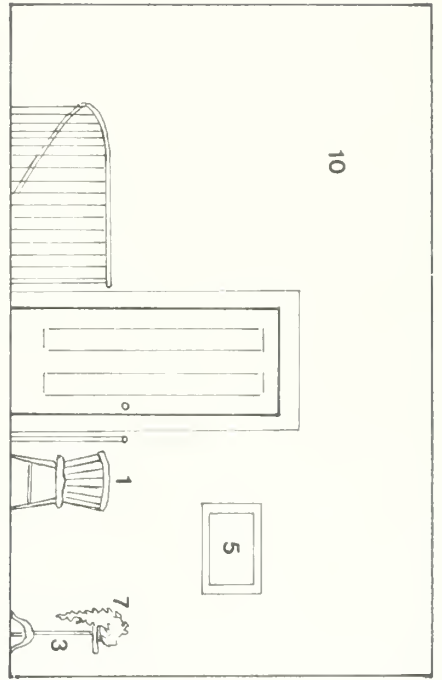
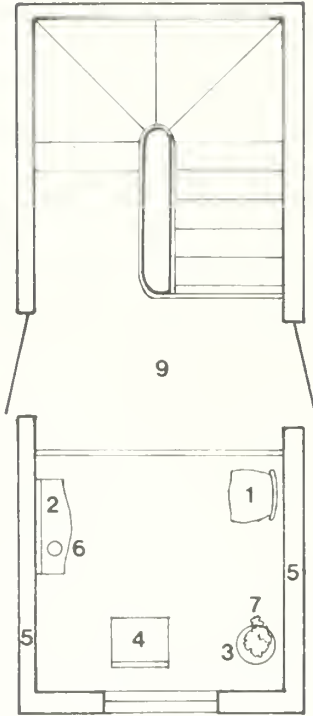
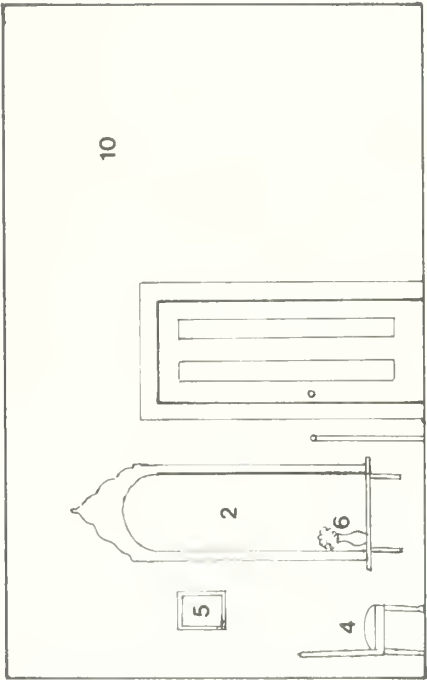
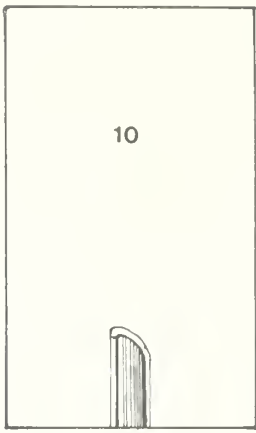

# Second Floor Hall



SPECIAL INSTALLATION, MAINTENANCE AND PROTECTION RECOMMENDATIONS  
(Diana R. Pardue)

This section contains instructions on maintaining a safe environment for museum objects in the historic house, performing necessary collection maintenance, and maintaining adequate security. See Part D for potential sources of assistance in implementing this section.

A. THE ENVIRONMENT

Maintaining a stable environment within a furnished building is crucial for long-term preservation of the historic furnishings. Part C contains a list of elements destructive to historic furnishings (Agents of Deterioration), and includes recommended light and humidity levels to sustain a proper museum environment.

1. Temperature/Relative Humidity

The park is installing a heating and air conditioning system in the Home so that the climate can be controlled. Once this installation is operating, the relative humidity and temperature should be maintained constantly at the recommended level, without regard to time of day or season. Temperature and humidity readings can be taken on a regular basis to determine how well the climate control system is working. Recording hygrothermographs should be placed on the first and second floors, out of reach of

curious visitors, but in rooms containing historic furnishings. These weekly charts will indicate if there are any problems with the existing climate control equipment and help to justify any needed changes.

An average internal relative humidity of 55% should be maintained year round. Recognizing the difficulty of such precise control and taking into consideration the needs of the historic structure, an acceptable alternative is 45% or higher relative humidity in the winter and 65% or lower in the summer. Such a broad range in relative humidity is acceptable only if the change from the wintertime low to the summertime high, and back again, is slow and regular. The daily relative humidity should vary less than 5% and monthly variations should occur at a rate of 1-2%.

Ideally the inside temperature should be about 70°F year round. However, an acceptable temperature for winter is 60°F, and for summer 75°. Changes in temperature must also occur gradually following the same rates as with relative humidity.

(Manual for Museums, pp. 67-69; Conserve O Grams 3/6 and 3/7)

## 2. Light

Controlling both visible and ultraviolet light will prevent fading and weakening of fibers in organic materials (wood, textiles, paper, leather).

Ultraviolet filters that also filter some visible light should be placed on the windows in all of the furnished rooms. The window shades should also be used by lowering them as necessary to reduce the amount of direct sunlight coming into the rooms.

Fluorescent lighting is more harmful to objects because of the higher ultraviolet levels. The fluorescent lights above the doors must be removed. Lighting from the hallway should be sufficient to allow visitors to see the furnishings and get a more realistic sense of what the house was like when the Lincolns lived there, before electricity. If any type of additional artificial lighting is needed, incandescent lighting with low light levels should be used.

The length of time the furnishings are exposed to light can be reduced by eliminating the fluorescent lights and completely lowering the window shades when no visitors are present.

(Manual for Museums, p. 69; Conserve O Grams 3/3, 3/4, and 3/5)

### 3. Dust/Insects/Rodents

The park has a contract with a local company to fumigate the house monthly. This contract should continue. Once the climate control system is installed, the windows and doors should stay shut, eliminating a significant source of dust and insects.

Insect and rodent inspections by the park staff should occur weekly, and appropriate actions taken where needed. To minimize insect and rodent activity, food and drinks should not be allowed in the house.

(Manual for Museums, pp. 65 and 69-77; Conserve O Grams 3/9 and 3/10)

#### 4. Fire

As indicated in Section B, page 3, the house has a fire detection system that includes both ionization detectors and fixed temperature detectors. This system is connected directly to the Springfield Fire Department on a constant basis. Installation of a fire suppression system is now being studied by the Physical Security Coordinator in the Midwest Regional Office. In the meantime, hand extinguishers should be readily available in the Home and all staff members should know how to use them.

The park should invite senior officials and battalion chiefs in the Springfield Fire Department to visit and inspect the house, to become thoroughly familiar with the Home and its furnishings so that they can fight a fire there with minimal damage from hose streams and possible forced entry. This visit should take place twice a year.

An emergency action plan should be available for implementation in the event of natural disasters, fire, civil unrest, and

bomb threats. It should delineate responsibilities of park employees to minimize danger to life and property. The staff must be made aware in advance of actions designed to save the more valuable museum objects. A plan for the safe evacuation of visitors and staff must be posted.

Fire drills held on a regular basis are one of the best ways to ensure the proper response to an emergency. Thinking out responses ahead of time makes dealing with the real emergency much easier.

Good housekeeping can be the most important single factor in the prevention of fire. No smoking should be allowed in the furnished sections of the house.

( Manual for Museums, pp. 77 and 292-297; Conserve O Gram 2/4)

## 5. Security

Protection of the furnishings is provided by visitor barriers, mechanical intrusion systems, and park employees. See Section B, page 3, for more detailed information on these three security systems.

The number of people visiting the house should not exceed fifteen per interpreter so that the interpreters are able to keep an eye on the visitors. Hopefully, the presence of the interpreter(s) will act as a deterrent to vandalism or theft.

Park employees must insist that visitors do not touch the furnishings. Only the Museum Aide and any necessary assistants should handle the historic furnishings and then as little as possible, and only with clean hands. Metal objects should not be handled without clean cotton gloves.

Small objects can be protected from unnecessary handling or theft by placing them out of reach of visitors, or securing them to large objects. Reproduction objects should be used in place of historic objects if proper protection otherwise cannot be provided.

Park employees should conduct walk-through examinations and visual inventories several times daily. Missing or damaged objects should be reported immediately to the Superintendent, and Incident Reports (Form 10-434A) completed and sent to the Regional Office.

The museum records system is an additional security device. An up-to-date system contains object locations and descriptions. Most of the furnishings are accessioned and catalogued but objects acquired from the State of Illinois need to have the State inventory seals and metal I.D. tags removed to avoid any confusion. Additionally, some of the objects are numbered incorrectly or no longer have catalogue numbers on the objects. These objects must be renumbered to ensure proper accountability.

Location files, part of the records system, should be established, using salmon-colored catalogue cards (Form 10-254A). Each card should contain the object name, location (building, room, where in room), a brief description, catalogue number, and accession number. These cards should be kept in the house and organized by room, type of object (chair, table, painting, etc.), and numerical sequence by catalogue number.

Photographs showing object placement should be available for each room. Depending on size, rooms can be photographed in sections of four or more, and labeled A, B, C, etc. The contents of closets can be included. These photographs can be kept on Print File Cards, (Form 10-30), and filed by room. The park has started a security slide file of furnishings in the Home. This file should be completed and incorporated with the photographs showing object placement.

(Manual for Museums, pp. 77-78, 79-82, 278-291, and 281-297; Conserve O Gram 2/4)

## 6. Specific Conservation Considerations

1. Objects should never be placed next to, or on top of, functioning heating or air conditioning ducts, which will dry out wood, textiles, leather, and paper objects.

2. When placing objects such as lamps, candlesticks, books, and other small objects on other materials (textiles, finished wood surfaces, paper, or leather), protective barriers should be placed between the objects to prevent the transfer of corrosion or chemicals, and to evenly distribute weight. Suitable protective barriers are: acid-free cardboard; museum mat board (100% rag); or polyethylene foam. An example is placing a circular disc of acid-free cardboard between a candlestick and a finished wooden mantel.

3. Pages of open books should be turned weekly to avoid excess damage to any two pages or the spine of the book.

4. No historic papers should be exhibited merely to recreate an historic scene; modern copies will have the same overall effect. Copies should be replaced monthly to create a fresh appearance.

5. Garments should be hung on either padded wooden hangers or padded pegs. Polyethylene foam or cotton batting, covered with cotton muslin, forms good padding. Only very strong textiles in good condition can bear the strain of hanging.

6. All framed paper materials (such as prints and photographs) should be matted with 100% rag board and framed according



to Conserve 0 Gram 13/1. Photographs should be matted with 100% rag board that has not been buffered.

7. Objects stored in drawers and cabinets need to be removed and stored correctly in the museum storage area.

8. Real food can be displayed in the house only if it can be in sealable containers or removed from the Home when it is not open to the public (overnight and on holidays). Having food laying around in the kitchen certainly brings life to the room but at the expense of attracting insect and rodent infestations.

#### B. COLLECTION MAINTENANCE AND HOUSEKEEPING SCHEDULE

The Superintendent is responsible for the collection; all collection maintenance, as well as cleaning materials, must be approved by her/him. The Museum Aide responsible for collection maintenance should receive curatorial training, available through the National Park Service and through other institutions as appropriate to his/her curatorial duties.

#### General Rules for Handling Objects

1. Be aware that the objects should be treated respectfully. Haste makes for bumped, scratched, and broken objects; always schedule enough time to complete the task. Be thorough, but remember that over cleaning may be as harmful as no cleaning. Be gentle rather than enthusiastic.

2. Fingerprints leave deposits of dust, water, and oils where pockets of corrosion develop on metal objects. Always wear clean white gloves when handling metal objects (silver, brass, copper, steel, and iron) and leather objects. When the gloves become soiled, wash them in Ivory soap--do not use bleach. Always have clean, dry hands when handling other types of materials.

3. When moving any object, support that piece. Carry only items that can rest securely in both hands, and carry only one thing at a time. Never lift anything by its handle, spout, ears, rim, or any other protruding part. Support it from below at the base and at the side. Moving large pieces of furniture requires two or more people so that mishandling by tugging, pulling, and sliding is avoided. When several objects are moved that are small enough to fit in a basket, pad each object (along with the basket). Do not stack objects on top of each other. Do not allow parts of objects to protrude from the basket (or any container) while in transport. The loaded basket must be light enough to be carried easily.

4. Moving objects displayed above fireplaces or on high shelves require two people, using a ladder. One person should ascend the ladder, and using both hands, carefully transfer the object to the person on the ground. Lids or any removable parts should be firmly affixed or removed before moving.

5. Carry chairs by their seat rails; large upholstered chairs should be carried by two people. In most cases, tables should be supported by the skirt.

6. Plan ahead. Know where you are taking an object, what obstacles are on the way, and have the pathway cleared and padded if necessary.

7. If something breaks, report it to the Superintendent. Save all the fragments and keep them together.

#### General Recommendations for Using This Housekeeping Schedule

1. Discretion and sensitivity must be applied in following this housekeeping schedule. Dusting and cleaning museum objects should be based on need and condition. Cleaning frequency may vary, depending on the location of the object in the house (for example, if it is close to an exterior door), the season of the year, and the level of visitation. Judgment should be exercised accordingly by the person with curatorial duties. The less handling an object receives, the longer it will survive.

2. When dusting, the dust should be removed--not just pushed around. When some objects are dusted with a dry cloth or artist's brush, use a vacuum cleaner to pick up the dust that is lifted off of the object and into the air. Vacuuming is the best

method of dusting, but a variety of suction devices should be used, depending on the stability and age of the object or surface. A plastic mesh screen should be used on fragile surfaces to relieve strain. Metal, glass, and ceramic objects on mantels or high shelves should be dusted in an area removed from the furnished area. When clean, they can be returned to their exhibit location. Be very careful when handling these objects --this action requires two or more people.

3. During seasons with lower visitation levels, the daily, weekly, and monthly tasks can be done with less frequency. Biannual tasks should be done in the spring and at the end of fall. Annual and biennial tasks should be done during winter months.

### Specific Recommendations

#### Ceramics and Glass

Once a year, ceramic and glass objects should be examined to see if additional cleaning is needed. Clean these objects according to the directions in Conserve O Gram 8/2. Do not immerse unglazed portions of earthenware. Instead, wipe these sections with a damp cloth or artist's brush.

#### Marble

Dust with a clean cotton cloth. Once a year, examine to see if more cleaning is necessary. Clean by using a damp cloth. If

dusting is done on a regular basis, more cleaning should not be necessary.

### Textiles

1. Vacuuming: Fibers should be tested initially for stability. Turn the suction down to the lowest level. Carefully vacuum a small, unnoticeable section of the textile, holding the plastic mesh screen over the textile to eliminate strain. Then check the area vacuumed for loose fiber ends. If none are visible, continue vacuuming the textile using the brush attachment. Use the plastic mesh screen on fragile areas to eliminate strain.

Vacuum upholstered furniture using the upholstery attachment and, where needed, the plastic mesh screen. Place the screen against the upholstery and vacuum over it. Work dust out of corners, pleats, and tufts with a clean brush attachment.

2. Cleaning: Reproduction textiles can be dry-cleaned by a dependable dry cleaner, once a year or as needed. Historic textiles should be cleaned by a professional textile conservator. If there is a question as to whether a textile can be cleaned by the curatorial staff, consult with the Regional Curator or the Textile Conservator in the Division of Conservation.

## Metals

1. Brass, copper, and silver objects should be polished and lacquered to avoid polishing every year. A coat of lacquer should last a long time (around 10 years); inspect objects yearly for tarnished spots, indicating that the lacquer needs replacing. (See Manual for Museums, pp. 66, 244, 249, and 258.)

Lacquering can be done on contract. Contact the Regional Curator for assistance with this project. The Metals Conservator, Division of Conservation, can be consulted for additional assistance.

2. Iron and steel objects can develop rust and corrosion. If this occurs, see Conserve O Gram 10/1 for information on further treatment.

3. Stoves can be polished with stove blacking.

4. Excessively dirty metal objects can be washed. Do not wash objects with sections made of other materials, such as bone or wood. If dusting is done regularly, washing should not be necessary. Washing should never occur on a regular basis.

Procedure for Washing:

Wash in warm water and non-ionic detergent; rinse in clear water and dry completely with a soft clean cloth.

5. Pewter should be polished only when absolutely necessary; a light coat of microcrystalline wax is usually sufficient for protection. Wash only if the object is very dirty; this dirt build-up should not occur if the objects are dusted regularly. Do not wash on a scheduled basis.

Procedure for Washing:

Wash in denatured alcohol; rinse well in distilled water and dry with a clean cloth.

### Fireplaces

Procedure for Cleaning:

Equipment: Soft, clean cloths, pail of clear water, gloves, sponge.

Procedure: Vacuum clean. Damp wipe the hearth with a sponge dipped in clear water. Dry with a soft, clean cloth.

### Maintenance Staff Projects Accomplished in Consultation with Superintendent

#### Windows

Biannual Cleaning: The windows should be washed inside and out. No liquid should run onto the wooden framework. The Museum Aide

washes the interior of the windows; the maintenance staff washes the exterior.

Equipment: Two people, ladder, chamois, pail, sponge, cleaning solution.

Procedure: Dust window panes and surrounding framework. Dampen sponge in cleaning solution and use overlapping strokes to wash each pane. Remove dirty water from the pane with chamois. Change water when it becomes dirty.

### Ventilation System

Biannual Cleaning: Contact the maintenance staff and request them to clean the HVAC ducts and registers. The heating and air conditioning equipment should also be cleaned; any filters should be cleaned and replaced.

### Housekeeping Schedule

#### Daily

1. Vacuum floors and baseboards. Do first floor one day, second floor the next day.
2. Dust stairway balusters and railings with a clean cotton cloth sprayed with Endust. Alternate floors as above.



3. Damp wipe surfaces extensively handled by visitors (room barriers, woodwork, entrance and exit door handles, and stair railings).

4. Vacuum floor covering for visitor traffic.

5. Set clocks and wind as needed.

6. Check condition of live plants and flowers.

#### Weekly

1. Dust finished wood furniture with a clean cotton cloth sprayed with Endust. Dust unfinished and painted wood objects with a clean cotton cloth. Dust all parts of the piece including the out-of-the-way places. Use a soft cotton swab if necessary (Conserve 0 Gram 7/8). During periods of high visitation, dusting may be needed more often.

2. Dust ceramic, glass, paper, baskets, and other small objects on display using a clean dry cotton cloth. Use an artist's brush on intricately decorated objects and art objects. Do the first floor one week, the second floor the next week. Dusting can be done on a weekly basis if needed because of high visitation.

3. Vacuum leather materials, books, and lamp shades, using a gentle suction through the plastic screen. Wear clean cotton gloves. Do floors alternately as above.

4. Dust metal objects and marble, using a clean, dry cotton cloth. Always wear clean cotton gloves when handling metal. Do floors alternately as above.

5. Clean soiled gloves in Ivory soap; rinse and dry.

6. Water live plants; change flowers if needed.

7. Change vacuum cleaner bag.

8. Vacuum hearths, mantels, and fireplaces.

9. Spot clean floor covering for visitor traffic.

10. Check for evidence of insects and rodents. (See Manual for Museums, pp. 71-77.)

### Monthly

1. Vacuum the curtains, window shades, and lighting fixtures.

2. Vacuum upholstery on historic furniture, using gentle suction and a clean upholstery attachment. Fragile areas should be vacuumed through a plastic mesh screen to decrease strain.

Always vacuum in the direction of the nap if the material has a nap.

3. Dust frames (picture and mirror), using a lens brush, or with carved gilt frames, blow with a small ear syringe (do not touch the frame with the tip).

4. Glass on mirrors and pictures may be damp wiped (if needed), using a sponge dipped in glass cleaner (Conserve O Gram 8/2) and squeezed almost dry. Do not let the moisture get on the frame or under the glass.

5. Replace scattered paper with fresh sheets.

6. Refold folded textiles along different lines to reduce stress.

7. Spot clean walls with a clean, water damp cloth and dry.

8. Vacuum tops of doors, window sills, bookcases, and other ledges in reach of the floor.

9. Examine exhibited objects to determine if active deterioration is occurring and if specialized conservation treatment is needed.

10. Damp mop/buff the ceramic tile and wood floors.

### Semi-Annual

1. Vacuum ceilings, high walls, and other areas requiring ladders for access.
2. Clean kitchen floor following procedures in the Manual for Museums, pp. 222-231.
3. Wash and dry windows.
4. Clean ducts and registers.
5. Clean or replace filters in the heating and air conditioning systems; clean this equipment.
6. Take objects out of cupboards and bookcases; dust objects as well as shelves, using a clean, dry cotton cloth.

### Annual

1. Check metal objects for corrosion, rust, or tarnish; treat if necessary.
2. Wash and dry ceramic and glass objects, if necessary (Conserve O Gram 8/2).
3. Clean woodwork (not furniture) by wiping with a clean, damp cloth and dry immediately.
4. Clean hearth, mantel, and fireplace (only if necessary).

5. Dry clean or wash reproduction curtains and bed linens if needed.

6. Clean floor covering for visitor traffic.

7. Black stoves if needed.

#### Biannual

1. Clean and wax finished wood furniture (Conserve 0 Grams 7/2 and 7/3).

2. Damp wipe and dry painted wood and raw wood objects, using a clean cloth with water (Conserve 0 Gram 7/2).

3. Clean exposed wood floors by stripping, waxing, and buffing (Conserve 0 Gram 7/4).

4. Dry clean reproduction drapes if needed.

#### C. AGENTS OF DETERIORATION

Proper care of a museum collection consists of reducing the rate of deterioration to a minimum by housing the collection in a safe environment. A safe environment will prolong the life of an object and minimize conservation treatment. Prevention is always better than treatment.

The Manual for Museums includes a chapter on caring for a collection. The sections on agents of deterioration (pp. 67-82)

and climate control (pp. 83-91) should be read carefully. Another good source to become familiar with is The Museum Environment by Garry Thomson. It contains useful information on lighting, humidity, and air pollution.

Damaging conditions are:

Too much or too little humidity

45% - 65% is an ideal range; metals and photographs do best at 40% or below. At very low levels, organic materials dry out and become brittle; at high levels mold may develop on organic materials and metal will begin to corrode. Manual for Museums, pp. 67-68 and 83-89.

Too much or too little temperature

60°-70°F is the best range, cool enough to prevent mold but warm enough to permit working comfortably. The greatest danger lies in the variation of temperatures. Rapid and wide variations can cause dangerous expansion and contraction of some objects. Manual for Museums, pp. 68-69, 83-86, and 89.

Too much light \*

50 Lux - Textiles, watercolors, prints and drawings, paper, wallpapers, dyed leather, most natural history objects (botanical specimens, fur, feathers, etc.).  
(5 Footcandles)

150 Lux - Oil and tempera paintings, undyed leather,  
(15 Footcandles) er, horn, bone, ivory, and oriental lacquer.

300 Lux - Other objects.  
(30 Footcandles)

\*Garry Thomson, The Museum Environment (London: Butterworths, 1978), 23.

Ultraviolet light should be filtered out. The length of time an object is exposed to light is equally important. Use light only when necessary. Manual for Museums, pp. 69, 86, and 90-91.

#### Chemical Air Pollution

Common air pollutants include industrial fumes, motor vehicle exhausts, and salts from the ocean. Materials such as unseasoned woods, paints containing lithopone (in the pigment), unpainted hardboard, acidic papers and plastics also release harmful vapors. These materials should be avoided in construction of exhibit cases or storage equipment. Manual for Museums, pp. 70 and 91.

#### Dust

It acts as an abrasive, provides nuclei for moisture condensation and will soil the surface of objects. Once an object is

covered with dust, the removal process can accelerate wear and increase the possibility of physical damage. Manual for Museums, pp. 69-70 and 91.

#### Mold (also called mildew)

This growth probably destroys more objects than anything else. It will grow on any organic object in an atmosphere of more than 65% RH and 80°F. Look for velvety patches or areas of discoloration. Avoid warm, damp environments. Manual for Museums, pp. 70-71 and 39.

#### Insects

The most common insects to watch for are powder-post beetles, clothes moths, silverfish, dermestid beetles, and cockroaches. Their damage is rapid and irreversible. Manual for Museums, pp. 71-76.

#### Rodents

In a very short time these animals can destroy a collection by their eating and nest-making. Watch for droppings, signs of gnawing and rodents themselves. Manual for Museums, p. 77.

#### Fire

A fire can wipe out an entire collection very quickly. Keep flammables in special fire-resistant containers. Work out a fire



emergency action plan with staff and local fire-fighting organization. Manual for Museums, p. 77.

### Humans

Human hazards to the collection are careless handling (by visitors and staff), vandalism, and theft. The security of the collections depends primarily upon the staff. Manual for Museums, pp. 77-82.

### D. SOURCES OF ASSISTANCE

Persons responsible for the care and protection of museum objects should be familiar with Ralph Lewis' Manual for Museums (National Park Service, GPO, 1976), the Conserve O Gram series, and the NPS Museum Handbook. Sections in the Manual for Museums which are particularly useful for implementing these recommendations are Chapter 4, "Caring for a Collection," pp. 61-112; Chapter 11, "Housekeeping," pp. 204-259; and Chapter 12, "Protection," pp. 260-298.

Other useful publications are:

Committee on Libraries, Museums, and Historic Buildings. Protection of Museums and Museum Collections 1980. NFPA 911. Boston: National Fire Protection Association, Inc., 1980. One of the best sources on fire protection and prevention, specifically written for museums.

Edwards, Stephen R., Bruce M. Bell, and Mary Elizabeth King. Pest Control In Museums: A Status Report. Lawrence, KS: Association of Systematic Collections, 1980. a good guide to pesticides, their use in museums, and common insect pests.

Thomson, Garry. The Museum Environment. London: Butterworths, 1978. An excellent source of information on light, humidity, and air pollution.

Useful audiovisual programs are:

"Housekeeping Techniques for the Historic House," "Museum Fire Security," and "Site Security." These programs are produced by the American Association of State and Local History.

Additionally, the Regional Curator, Midwest Regional Office, and the Curatorial Services Division, WASO can provide assistance and further information for managing the museum collection.

LIST OF APPENDICES

	<u>Page</u>
<u>APPENDIX I:</u>	379
J. M. Fordin Affidavit which accompanied sofa (accession no. 1920.246) now at the Chicago Historical Society, Chicago, Illinois.	
<u>APPENDIX II:</u>	387
Mary Edwards Brown Affidavit, May 2, 1925, Lincoln Home files, Illinois State Historical Society Library.	
<u>APPENDIX III:</u>	393
Fannie Somerville Affidavit, December 12, 1934.	
<u>APPENDIX IV:</u>	395
Robert Watson Kuecher Affidavit, 1962.	
<u>APPENDIX V:</u>	399
Lincoln-Associated Furniture at LIHO.	
<u>APPENDIX VI:</u>	403
Articles of Clothing Purchased by the Lincolns in Springfield.	
<u>APPENDIX VII:</u>	409
Items loaned to the Illinois State Historical Society Library from 1924 to 1927 from the Oliver R. Barrett Collection.	



APPENDIX I

J.M. Fordin Affidavit

## CHICAGO HISTORICAL SOCIETY

Accession No. 1920.246

Negative No. \_\_\_\_\_

Date March 30, 1920

Source Purchased by the Society  
Collection: Charles F. Gunther

Object *Sofa*Material *Mahogany, horsehair*Country *United States*Artist or Maker *Victorian style*Date *c.1850-1855*Dimensions *H:32½" W:27½" L:6'8½" Condition Good*

Description *Sofa with mahogany frame and transitional serpentine-arched top rail with a carved fan shaped design in center. It is upholstered in black horsehair.*

## Remarks

Owed and used by Abraham Lincoln (1809-1865) at the time of his election to the Presidency (1860).

Bought of Mrs. Lincoln by J. M. Fordin, and removed by him from Mr. Lincoln's residence the day before his departure for Washington City, February 1861. Property sold on 27th day of April, 1887, to George W. Forden.

See Authority File

## Subject Headings

BIOGRAPHY - LINCOLN, ABRAHAM (1809-1865) - RESIDENCES

FURNITURE - SOFA

\_\_\_\_\_  
\_\_\_\_\_  
\_\_\_\_\_

Lincoln

Office of **TURNEY ENGLISH,**

Solo.

1920.246

*Real Estate Auctioneer,*

Dealer in Real Estate.

Attends to Stock Sales any Place in the State. Will Sell all kinds of Merchandise.

Springfield, Ill., Oct. 11<sup>th</sup> 1888

Mr C. F. Gunther

Dear Sir

I am in receipt of yours of the 10 inst saying you would take the sofa & requesting a description of it & the Wood etc. I reply enclosing copy of the sworn statement of J. M. Forder who bought it of Mrs Lincoln the day before their departure to Washington City D.C in February 1861 - to wit Mahogany Sofa - Mohair Cloth. J. T. Wright a Grocer of this city, who knows all about the sofa, when & by whom purchased, makes sworn statement to the same. On the 27<sup>th</sup> day of April <sup>1887</sup> I sold this sofa at Public Sale & George W. Forder became the owner & still has it in his possession. The Clerk at this sale verified the foregoing as the Transfer at said Sale, from Forder to Forder.

Please advise me where & how to send it, <sup>to</sup> you. It will be necessary to have it Packed to prevent its being injured I can have this done & settle for it & charge to you I await your further instructions & have notified Mr Forder that you would it by mail he is out of the city to day.

I am Respectfully  
Yours Truly  
Turney English

Lincoln, Ill

Office of **TURNEY ENGLISH,**  
Real Estate Auctioneer,

Dealer in Real Estate,

Attends to Stock Sales any Place in the State. Will Sell all kinds of Merchandise.

Springfield, Ill., Oct 20 1858

C F Gunther

Dear Sir

You find Enclosed. Ship's Bill  
& sworn Statement relating to the Lincoln Sofa.  
Mr London informs me that there was another Sofa,  
as he was told but he has no Personal Knowledge of  
it or what became of it he lived 3 days from Mr  
Lincoln when he bought this one & it is as represented  
in the Sworn Statement. If I can find any letters or  
other relic I will advise you.

I repaid the Fr as you see \$ 1.03 and for Parking  
38<sup>cts</sup> which you is receipted. The Sofa \$ 75.00 Total \$ 79.53  
dollars you will send Draft for this amount by  
the Early part of next week say Tuesday as Mr London  
is leaving for the west make Draft payable to my order  
as he may be gone before I get it.

I am Respectfully  
Turney English



State of Illinois,  
Sangamon County,

J.M.Forden of the City of Springfield, County of Sangamon, and State of Illinois, being duly sworn, deposes and says that the following described article of furniture, now owned and possessed by G.W.Forden, to-wit One Mahogany Sofa, which was owned and used by Abraham Lincoln at the time of his election to the presidency of the U.S. and that said furniture was bought of Mrs Lincoln by said J.M. Forden, and by him removed from Mr Lincoln's residence the day before his departure for Washington City in February 1861.

Subscribed, and sworn to before me this 11th day of May 1887.

*J. M. Forden*  
*A. H. Gehlman*  
*Notary Public*

J.T.Wright, of said City, County and State being duly sworn, says that he is well acquainted with the said J.M.Forden, and is personally cognizant of the fact stated in above affidavit, and that the same are true.

*J T Wright*  
*A. H. Gehlman*  
*Notary Public*

Subscribed and sworn to before me this 11th day of May 1887.

Turney English of said City, County and State, being duly sworn, says that he was Auctioneer of above described property and was sold on the 27th day of April 1887, to Geo W.Forden, of Sangamon County, State of Illinois, he being the highest bidder.

*Turney English*

Subscribed and sworn to before me this 11th day of May 1887.

*A. H. Gehlman*  
*Notary Public*

S.H.Gehlman further deposes, and says that he was Clerk at said sale, and said property was sold as stated above.

*A. H. Gehlman*

# THE CHICAGO & ALTON RAILROAD CO.

*Oct 24/88*

Received from *R. H. Ambrose*

the packages numbered and described as follows, in apparent good order (contents and value unknown) to be transported on the line of this Road from *Sped* to \_\_\_\_\_

Station, and delivered in like good order to the consignee or owner, at said Station last mentioned, or (if the same are to be forwarded beyond said Station) any Company or Carrier receiving, or which may receive freight from said CHICAGO AND ALTON RAILROAD COMPANY, for the purpose of transporting the same towards the place of destination of said goods or packages; and the CHICAGO & ALTON RAILROAD COMPANY guarantees that the rate of freight for transportation of said packages from the place of shipment to \_\_\_\_\_

shall not exceed \_\_\_\_\_ per \_\_\_\_\_ and charges \_\_\_\_\_ advanced by this Company.

### SUBJECT NEVERTHELESS TO THE FOLLOWING CONDITIONS

The duty of this Company shall be considered fully performed and accomplished and the liability of the Company its carriers terminated, on the arrival of the goods or property at said station, or by delivery or tender to carrier as above provided.

This Company shall have the right, at any time after the arrival of said goods, in case they be not called for previously, to store the same in any warehouse at the expense and risk of owner.

This Company shall not be responsible for any damages occasioned by delay from any cause, leakage of Oil or Liquids, breakage of Glass, Glassware or Crockery, injury to the hidden contents of packages, or for decay of perishable articles, or injury by heat or frost or by reason of improper packing when received at their depot; nor shall it be responsible for a greater amount than Two Hundred dollars on any package, except by special agreement and upon payment of extra rate; or for loss or damage to goods occasioned by providential causes, as by fire, while in transit at station.

All claims for damages or shortage shall be made before the goods are taken away from the station where delivered.

In the event of the loss of any property for which this Company may be responsible under this receipt, the value or cost thereof, at the point or time of shipment is to be taken as the measure of damage; and the Company, in case of loss or damage to any of the goods named in this receipt, for which the Company may be liable, shall have the benefit of any insurance effected by or on account of the owner of the goods.

Gunpowder, Friction Matches, and the like combustible articles, will be taken by special agreement only; and, if otherwise shipped, in case of damage, the shipper or consignee will be held responsible therefor.

Freight to be paid according to weight by this Company's scales. All packages subject to charge for cooerage when necessary.

No agent of the Company is authorized to contract for the transportation of any freight beyond the stations on its line, or to make any contract for the transportation of freight within any special time.

The Company will only be responsible as warehousemen after the arrival of freight at station of its destination on the line of this company.

*[Handwritten signature]*

MARKS AND CONSIGNEES.

ARTICLES.

Weight Subject to Correction.

*@ J. Guthrie  
Chicago  
Ill.*

*Lounge Seats  
OK  
220  
@ J. Quinn*

*Pre Paid  
\$ 1.00*

Lincoln Sofa.

Springfield, Ill., Oct 20 1888

Mrs. Turney English

To R. H. ARMBRUSTER, Dr.

DEALER IN AND MANUFACTURER OF

Parlor Furniture, Mattresses, Feathers and Bedding.

UPHOLSTERING A SPECIALTY.

323 SOUTH FIFTH ST.  
Sign of the Swan.

STEAM FEATHER RENOVATING.



<p>70 Pack and Ship over Sofa to C. F. Smither 212 State Street Chicago Ill Per Packet R. H. Armbruster</p>	<p>3.80</p>
---	-------------

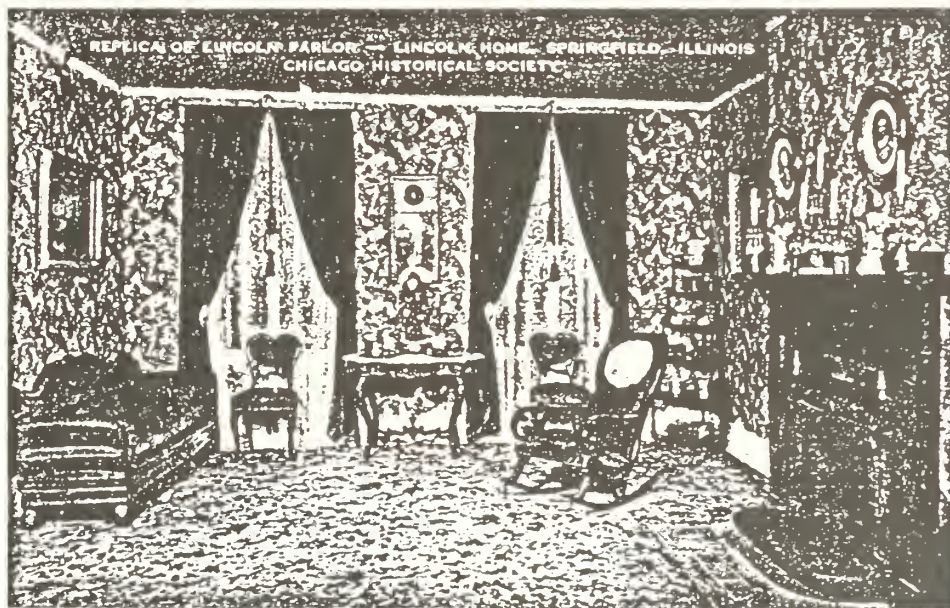



Mississippi

Live Oak

of Georgia

212 State Street

Mohogany Sofa  
Chicago  
2012  
paper

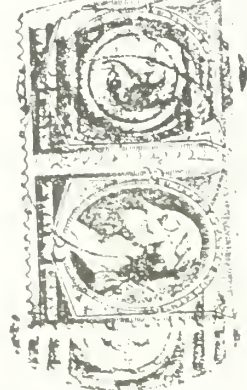

APPENDIX II

Mary Edwards Brown Affidavit

State of Illinois )  
                  ) SS  
County of Sangamon )

I, Mary Edwards Brown, of the City of Springfield, in the county and State aforesaid, do hereby certify that I am the grand-daughter of that Ninian Edwards who, in 1833 married Elizabeth P. Todd, a sister of Mary Todd, afterwards the wife of Abraham Lincoln; that Mary Todd lived with her sister, Mrs. Ninian Edwards, and was married to Abraham Lincoln at her home in Springfield, Illinois; and that the articles hereinafter enumerated belong to me, having come into my possession by inheritance from various members of the Edwards family:

1.

3 astral or sperm oil lamps with their original globes, which furnished the lights for Abraham Lincoln's wedding at the N. W. Edwards home.

2.

An old Sheffield tray which was used at the wedding. It once belonged to Governor Ninian Edwards.

3.

Sofa which Lincoln courted his wife on (hair cloth on back original).

4.

Mahogany sideboard which held the cake for wedding, once property of Governor Ninian Edwards.

5.

Mahogany table which Abraham Lincoln often played chess on in the Edwards home.

6.

Work basket of Mrs. Abraham Lincoln.

7.

Bill book used and carried by Abraham Lincoln while in Springfield, Illinois.

8.

Several books of Mrs. Abraham Lincoln with her name in book, in her own handwriting.

9.

Original bank check of Abraham Lincoln. Original campaign tickets. Legal documents in frame, in Abraham Lincoln's own handwriting.

10.

Interest receipt to N. W. Edwards in Lincoln's handwriting.

11.

3 original letters of William Wallace Lincoln to Henry C. Remann.

12.

Old haircloth mahogany rocker which Abraham Lincoln often sat on, holding the children on his knees.

13.

Paper lanterns which were used to decorate Mrs. Remann's porch during Lincoln campaign for President.

14.

Carriage robe used by the Lincoln family.

15.

Penholder set, property of Abraham Lincoln.

16.

Tablecloth which was used for the wedding meal.

17.

Basket with flowers placed on Abraham Lincoln's casket by General Sherman.

18.

A piece of arborvitae tied with crepe (in a box, donor unknown). A funeral piece.

19.

Piece of tree trunk (elm) which stood in front of the Lincoln Homestead, planted by Abraham several years before he left Springfield for Washington, D. C.

20.

Pink shawl, diamond ring set in black onyx, pin, ear rings, locket and beads of black onyx; gold locket and bracelets (chain) and various other pieces of clothing.

21.

A handmade night robe, made by Mrs. Lincoln, with M. L. embroidered on it.

22.

Various pieces of original wood from Abraham Lincoln's Homestead in Springfield, Illinois. Many pictures framed in it.

23.

Rosewood parlor furniture and old tables, mirrors, chairs, etc., once the property of Ninian W. Edwards, which were in the house when Lincoln married.

24.

Cup and saucer used by the Lincolns in Washington, D. C.

25.

Mahogany wardrobe which was used by Mrs. Lincoln in the Edwards home.



26.

Old door and window locks from the Abraham Lincoln  
Homestead.

Mary Edwards Brown

Subscribed and sworn to before me this 2nd day of May,  
A.D. 1925.

Edna Mae Smith  
Notary Public

My commission expires July 18, 1926.



APPENDIX III

Fannie Somerville Affidavit

HISTORY OF SIDBOARD  
OWNED BY CHARLES W. BROWN,  
MAGGIE, W. VA.  
\* \* \* \* \*

In the year 1858, Alexander Long of Mason County, then Virginia, purchased from Abraham Lincoln, at Springfield, Illinois, one mahogany marble top sideboard for the sum of \$100.00, which sideboard has come down through four succeeding generations to the present owner as follows:

1 - Alexander Long, born in the year 1802, and died in the year 1882, bequeathed this to his daughter, Elizabeth Long Brown.

2 - Elizabeth Long Brown, born in the year 1830, and died in the year 1906, bequeathed this to her son, Van B. Brown.

3 - Van B. Brown, born in the year 1858, and died in the year 1918, bequeathed this to his son, Charles W. Brown.

4 - Charles W. Brown, born in the year 1891, is now the present owner of this sideboard, and he resides in Mason County, West Virginia.

Fannie Somerville, born in 1856, who signs this history, is a grand-daughter of the above named Alexander Long.

*Fannie Somerville*

\_\_\_\_\_  
FANNIE SOMERVILLE.

STATE OF WEST VIRGINIA, )  
  ( To-wit:  
COUNTY OF MASON.                    )

I, L. C. ROUSH, a Notary Public in and for said County and State, do hereby certify that Fannie Somerville of Maggie, Mason County, West Virginia, this day personally appeared before me in my said County, and after being by me duly sworn, did depose and say that the above statements are true and correct to the best of her knowledge and belief.

And the said Fannie Somerville acknowledged her signature to the above writing.

Given under my hand this the 12th. day of December, 1934.  
My commission as Notary Public expires June 8, 1935 1937.

*L. C. Roush*

APPENDIX IV

Robert Watson Kuecher Affidavit

ROBERT WATSON KUECHER AFFIDAVIT, 1962

I, Robert Kuecher, now residing in Hollywood, California, being duly sworn, gives the following statements as my recollections of family knowledge concerning certain materials which were once the property of Abraham Lincoln and used in his Springfield, Illinois home.

The following articles, which were all acquired by my Grandfather, John Kuecher, from the Lincoln Home, are the last of the Lincoln Collection, outside of two chairs that are owned by John Kuecher, a nephew in Decatur, Illinois. My Uncle, Julius Kuecher, and others of the family told me that the only things Grandfather bought were the cabinet toilet set, quilt, and chair from the maid's room. I will list the antiques, and give their history as they were handed down through the years in the Kuecher family:

Purchased at the sale on Lincoln's death by John B. Kuecher:

1. Cabinet drawer stand, with white toilet set from maid's room.
2. Quilt from maid's room.
3. Child's rocking chair, always called "Tad's Chair" by our family.

These things were hauled to the John Kuecher home by a driver for Baum's Monument company. The toilet set and quilt were given to my parents for a wedding present. A desk and the rocking chair were delivered to my sister, Alice Harlow, during her first year at the old Lincoln School. They have been stored in her home at 1328 Monroe Street, Springfield, Illinois.

4. 50¢ and 10¢ American coins

were given to John Kuecher by Abraham Lincoln to purchase rope, and for helping to rope two of Lincoln's trunks. These coins were given to my Father by John Kuecher for a wedding present.

5. Couch from Lincoln Living room.
6. Wheelbarrow, (Lincoln's initial carved in handle) don't know final destination.
7. Lantern now in Valentine Collection.

Lincoln gave the couch to John Kuecher and helped deliver it to the Kuecher home in the wheelbarrow. The lantern was brought along to light Lincoln's way home. The lantern and barrow were given to John Kuecher by Lincoln because Lincoln would have no further use for them. The couch later went to my Uncle, Julius Kuecher, who later gave it to me and I gave it to Lincoln's Home where it is now, and an affidavit is on file with State of Illinois.

8. Books of Sermons.
9. Volume of Shakespeare.
10. (2) Presbyterian Hymn books.

Items 8 and 9 were given to Lincoln by a Springfield friend and were given to Elizabeth Kuecher, my Grandmother, by Mrs. Lincoln. Mr. Kuecher later gave the hymn books to my English Grandmother, Betsy Webster, and I inherited them from her.

11. Gold Cameo ring, given to me by my Grandmother on my 21st birthday. Owing to theater travelling, I left this ring in custody for safety with my Father. At his death, my Sister, Mrs. Harlow, kept it for me until her recent death. Lincoln gave this ring to my Grandfather, John Kuecher, about the time of his second inauguration and then passed on to my Grandmother, Elizabeth Kuecher who died in 1919.
12. Pearl and gold pen in case given by Mrs. Lincoln to my Grandmother.
13. Another pearl pen, not in case, from Lincoln home.

14. Pair of gold earrings with gold brooch, given by Mrs. Lincoln to my Grandmother before leaving for Washington, D.C. My Grandmother then gave them to my Mother for a wedding present.
15. (2) desk shears, or scissors from desk at Lincoln home.
16. Crystal glass paper weight, from Lincoln's home desk.
17. (5) Ivory letter openers or page cutters from Lincoln's desk.
18. Hammer, screwdriver, box opener, or nail puller, always kept in box and kept as "Lincoln Tools."
19. Framed picture of Church and yard, possibly from maid's room.
20. Silver tassels from Lincoln's catafalque when casket was in State House.
21. Clothes brush.
22. Dining room bell, (ivory handle).
23. Mahogany frame and glass (no picture, used for table top to display coins, and other Lincoln objects in my family's home).
24. Handmade copper tea kettle.
25. Wooden board used as gate latch.
26. Kitchen or porch chair formerly painted.
27. Bedroom Vienna bent wood chair formerly with cane seat.
28. Handmade child's table with drawer.

All items listed that I now own, I sell all right, title and interest to Emily E. Barker, Springfield, Illinois.



APPENDIX V

Lincoln-Associated Furniture at LIHO

FURNITURE WITH WELL-DOCUMENTED LINCOLN ASSOCIATION AT LIHO

The criteria used to determine the list of well documented Lincoln furniture was a combination of the existence of affidavits, the date on which they were written (those written closer to Lincoln's lifetime were given more credence), whether or not the item descended in a single family, and whether or not the item had ever formed part of a major collection of Lincoln items, such as the Lincoln Memorial collection.

- LIHO 6, Secretary-Desk
- LIHO 13, Couch or lounge
- LIHO 25, Drop-leaf table
- LIHO 29, Card table
- LIHO 46, Sewing table
- LIHO 47, Rocking chair
- LIHO 51, Hat rack
- LIHO 54, Wall clock, E. Howard & Co.
- LIHO 58, Wardrobe
- LIHO 60, Bureau
- LIHO 71, Sleigh type bedstead
- LIHO 75, Child's table
- LIHO 150-152, Girandoles
- LIHO 278, Sewing basket
- LIHO 301-305, Bottles
- LIHO 308, Lap desk

LIHO 559, Royal Oak cook stove  
LIHO 983, Queens of England, book  
LIHO 1059-1060, Sofas  
LIHO 1061, LIHO 1190, Fancy chairs  
LIHO 1114, Side table  
LIHO 1115, Mirror  
LIHO 1116-1121, Side chairs  
LIHO 1122, Bureau  
LIHO 1123, Mahogany Side Table  
LIHO 1124, Wardrobe  
LIHO 1126, Bureau

LINCOLN-ASSOCIATED FURNITURE WITH INCOMPLETE DOCUMENTATION AT LIHO

LIHO 24, Whatnot  
LIHO 28, Side chair  
LIHO 31-32, Side chairs  
LIHO 38, Rocking Chair  
LIHO 48, Footstool  
LIHO 56, Rocking chair  
LIHO 59, LIHO 66, Fancy chairs  
LIHO 64, Rocking chair  
LIHO 69, Shaving mirror  
LIHO 94, Rocking chair

LIHO 97, Blanket chest  
LIHO 102, Bureau  
LIHO 104, Walnut commode  
LIHO 126, Rocking chair  
LIHO 192, Transfer print plate  
LIHO 193, Ironstone bowl  
LIHO 195, Ironstone serving dish  
LIHO 196, China dinner plate  
LIHO 197, Creamware pitcher  
LIHO 255, Pressed glass cake stand  
LIHO 259, Glass pitcher  
LIHO 273, Stereoscope  
LIHO 290-291, Abalone shells  
LIHO 744, Wool shawl  
LIHO 787, Side chair  
LIHO 1062, Side chair

APPENDIX VI

Articles of Clothing Purchased by the Lincolns in Springfield

APPENDIX VI

ARTICLES OF CLOTHING PURCHASED BY THE LINCOLNS IN SPRINGFIELD

Irwin

Oct. 4, 1849	Child's Boots	\$ 1.75
Oct. 2, 1850	Cap	\$ 1.00
June 21, 1851	Shoes for Robert	\$ .75
July 7, 1851	Suspenders	\$ .50
Nov. 6, 1851	Bonnet	\$ 2.00
Jan. 16, 1852	Boots for Robert	\$ 1.75

John Williams & Co.

Oct. 10, 1851	1 Worked Collar, Per Lady	\$ 2.00
	1 Pair Slippers	\$ .50
July 10, 1851	1 Pair Slippers	\$ 1.00
Jan. 29, 1853	1 Boy's Cap	\$ .50
Feb. 16, 1854	1 Pair Boy's Boots, Per Lady	\$ 1.50
Jan. 23, 1855	1 Pair Overshoes	\$ 1.50
	1 Small Shawl	\$ 1.25
Jan. 27, 1855	1 Small Shawl	\$ 1.25
Mar. 31, 1855	1 Pair Boy's Boots by A. Lincoln	\$ 1.50
	1 Fr. Collar, Per Lady	\$ 4.00
May 20, 1856	1 Small Hat, Per Lady	\$ 1.00
	1 Pair Small Congress Garters	\$ 1.50

June 17, 1856	1 Pair Garters, Per Son	\$ 2.25
June 20, 1856	1 Pair Slippers, Per Son	\$ 1.00
Sept. 3, 1856	1 Bonnet, Per Lady	\$ 1.75
	3½ Yds. Bonnet Ribbon @ .30	\$ 1.05
	2 Pair Small Shoes @ .70 & @ .75	\$ 1.45
	3 Pair Lady's Slippers @ 1.00	\$ 3.00
Oct. 11, 1856	1 Pair Slippers	\$ 1.00
Dec. 15, 1856	1 Pair Kid Gloves	\$ 1.00
Dec. 16, 1856	To Exchange of Gloves	\$ .25
Jan. 7, 1857	1 Pair Slippers	\$ 1.00
Mar. 11, 1857	1 Pair Slippers, Per Lady	\$ 1.00
Dec. 26, 1857	1 Pair Linen Kid Gloves, Per Son	\$ 1.25
July 2, 1858	2 Fans, Per Lady	\$ 1.20
	1 Pair White Gloves, Per Robert	\$ .25
Dec. 31, 1858	1 Pair Kid Gloves Per Robert	\$ 1.00
Aug. 18, 1859	2 Pairs Heavy Drawers @ 1.25, Per Son	\$ 2.50
Aug. 20, 1859	1 Pair Drawers, Per Robert	\$ 1.25
Oct. 24, 1858	1 Pair Gloves for Bob, Per Lady	\$ 1.00
June 21, 1860	Pres. A. L. to R. Loon & Bro. - 1 Pair Small Heeled Boots for Tad	\$ 1.25

Dec. 12, 1860	1 Shawl	\$ 8.00
Dec. 13, 1860	1 Pocket Handkerchief	\$ .75
Dec. 24, 1860	4 Child's Silk Handkerchiefs	\$ 1.00
	4 Linen Handkerchiefs @ .15	\$ .60
	1 Gent's Silk Handkerchief	\$ .63
	2 Gent's Silk Handkerchiefs	\$ .90

C. M. & S. Smith, Springfield, Ill.

Jan. 28, 1859	1 Pair Shoes, Per Son	\$ .40
Mar. 21, 1859	1 Pair Gaiter Boots, Per Lady	\$ 2.50
	1 Pair Kid Boots	\$ 1.50
	1 Shirt	\$ 2.75
Mar. 26, 1859	1 Pair Kid Shoes, Per Son	\$ 1.50
Mar. 30, 1859	1 Boy's Hat, Per Lady	\$ 1.50
	1 Pair Boy's Shoes	\$ 1.25
Apr. 12, 1859	1 Boy's Hat, Per Lady	\$ 1.75
Apr. 26, 1859	1 Silk Hat, Per Lady	\$ 5.00
Apr. 27, 1859	2 Pair Stockings, Per Lady @ .35	\$ .70
Apr. 30, 1859	1 Pair Cott Shoes, Per Bob	\$ .50
May 6, 1859	1 Gent's Stock, Per Lady	\$ 1.25
May 12, 1859	2 Straw Hats @ .50	\$ 1.00
	1 Cravat	\$ .40
	Difference in Cravat, Per Son	\$ .25
May 19, 1859	1 Pair Silk Mitts, Per Lady	\$ 2.00
May 21, 1859	2 Silk Collars @ 4.00 & 2.50, Per Lady	\$ 6.50



June 3, 1859	1 Silk Cravat	\$ 1.00
June 11, 1859	2 Pair Boy's Socks @ .40	\$ .80
June 30, 1859	4 Handkerchiefs @ .20, Per Lady	\$ .80
July 7, 1859	1 Boy's Hat, Per Lady	\$ 1.25
	1 Boy's Hat	\$ .40
	1 Pair Boy's Gaiters	\$ 1.25
	2 Linen Handkerchiefs	\$ .60
July 12, 1859	1 Shirt Front, Per Lady	\$ .60
July 13, 1859	1 Pair Suspenders, Per Self	\$ .75
Aug. 6, 1859	1 Pair Boy's Shoes, Per Lady	\$ 1.10
Aug. 9, 1859	1 Hooped Skirt, Per Lady	\$ 3.75
Aug. 13, 1859	3 Linen Handkerchiefs, Per Lady	\$ 2.25
	3 Linen Handkerchiefs @ .50	\$ 1.50
Aug. 18, 1859	1 Linen Handkerchief	\$ .75
	1 Linen Handkerchief	\$ .30
Aug. 20, 1859	1 Pair Gloves, Per Lady	\$ 1.88
Sept. 6, 1859	1 Boy's Cap, Per Lady	\$ 1.25
Sept. 14, 1859	1 Gent's Stock, Per Lady	\$ 1.50
	1 Boy's Cap	\$ .75
	2 Pairs Boy's Socks @ .40	\$ .80
Sept. 22, 1859	2 Pair Boy's Boots @ 2.00, Per Lady	\$ 4.00
Oct. 5, 1859	1 Pair Kid Gauntlets, Per Lady	\$ 1.50
	1 Boy's Cloth Cap	\$ 2.25

Oct. 24, 1859	2 Pair Boy's Gloves @ .20, Per Lady	\$ .40
Oct. 24, 1859	2 Pair Boy's Gloves @ .40 1 Pair Gloves for Bob 1 Necktie	\$ .80 \$ .75 \$ .80
Nov. 17, 1859	2 Pair Wool Socks @ .40	\$ .80
Dec. 2, 1859	2 Boy's Hat @ 1.50, Per Lady	\$ 3.00
	1 Pair Gum Shoes	\$ .60

APPENDIX VII

Items loaned to the Illinois State Historical Society Library  
from 1924 to 1927 from the Oliver R. Barrett Collection

ITEMS LOANED TO THE ILLINOIS STATE HISTORICAL SOCIETY LIBRARY  
FROM 1924 TO 1927 FROM THE OLIVER R. BARRETT COLLECTION

- 1 fan (Mrs. Lincoln), carried by Mrs. Lincoln on the night of April 14, 1865
- 1 pearl handle pocket knife (Abraham Lincoln)
- 1 set of jewelry set with diamonds (Mrs. Lincoln), presented to Mrs. Lincoln by William Mortimer, September 12, 1863
- 1 onyx pin and one earring (Mrs. Lincoln)
- 1 box hair (Mr. Lincoln and Willie)
- 1 piece tablecloth from home of Governor Edwards used at Lincoln's wedding
- 1 book of theological lectures inscribed on inside "A. Lincoln, Nov. 30, 1860"
- 1 portfolio wallet "A. Lincoln"
- 1 photostat "Mr. Lincoln at Home" taken from Springfield Journal of November 1, 1858
- 1 book "Elements of Character" name of Mary Lincoln on fly leaf
- 1 picture pair beaded moccasins "A.L."
- 1 mirror in folding box with inscription "Made by Ben Carr to A. Lincoln, 1858, Springfield."

## SELECTED BIBLIOGRAPHY

### Primary Sources

- Acton, Eliza. Modern Cookery, In All Its Branches, Revised for American Housekeepers by Mrs. S. J. Hale. Philadelphia: Lea and Blanchard, 1845.
- Baringer, William E. Lincoln Day by Day: A Chronology 1809-1865. Washington: Lincoln Sesquicentennial Commission, 1960.
- Basler, Roy P., ed. The Collected Works of Abraham Lincoln. 8 vols. Springfield, Illinois: The Abraham Lincoln Association, 1953.
- Basler, Roy P. The Collected Works of Abraham Lincoln Supplement 1832-1865. Westport, Connecticut and London: Greenwood Press, 1974.
- Beecher, Catherine and Harriet Beecher Stowe. The American Woman's Home or Principles of Domestic Science. New York: J. B. Ford & Co., 1869.
- Beeton, Mrs. Isabella. The Book of Household Management. London: S. O. Beeton, 1861.
- Brown, Caroline Owsley, "Springfield Society Before the Civil War," Journal of the Illinois State Historical Society XV (1922-1923):477-500.
- Catalogue, Charles Hamilton Auction No. 81, The Waldorf Astoria, October 10, 1974.
- Catalogue, Charles Hamilton Auction No. 102, January 20, 1977.

Catalogue, Sotheby Parke Bernet Sale No. 4179, Pt. 2, November 14, 1978.

Coe, Charles H., compiler. A Descriptive and Historical Catalogue of the Oldroyd Lincoln Memorial Collection, 1896, unpublished ms.

Corneau, Octavia Roberts, ed. "A Girl in the Sixties: Excerpts from the Journal of Anna Ridgely," Journal of the Illinois State Historical Society, XXII (October 1929): 401-446.

Daily Illinois State Journal.

Downing, A. J. The Architecture of Country Houses. New York: D. Appleton & Co., 1850.

Godey's Lady's Book. Philadelphia, 1830-1855.

Grimsley, Elizabeth, "Six Months in the White House," Journal of the Illinois State Historical Society, XIX, 1927: 43-73.

Hale, Mrs. Sarah J. Keeping House and Housekeeping. New York: Harper & Brothers, 1845.

Hall, E.H., compiler. Springfield City Directory and Sangamon County Advertiser, 1855-1856.

Harris, Gibson William, "My Recollections of Abraham Lincoln," Woman's Home Companion, November and December, 1903, January and February, 1904.

Helm, Emily Todd, "Mary Todd Lincoln: Reminiscences and Letters of the Wife of President Lincoln," McClure's Magazine, XI (September 1898) pp:476-480.

Henkels, Stan V., compiler. Catalogue No. 731, The Valuable Collection of Autographs and Historical Papers Collected by The Hon. Jas. T. Mitchell...also The Entire Lincoln Memorial Collection of Chicago, Illinois, December 5 and 6, 1844 Illinois State Historical Society Library, Springfield, Illinois. The original, along with affidavits for the furniture, is located in the collections of the Historical Society of Pennsylvania.

Hertz, Emanuel. The Hidden Lincoln from the Letters and Papers of William H. Herndon. New York, 1938.

Horticulture, January 1, 1857.

Illinois State Register.

Koerner, Gustave. Memoirs of Gustave Koerner, 1809-1896.  
2 vols. Cedar Rapids: The Torch Press, 1909.

Leslie, Eliza. Miss Leslie's Lady's House Book. Philadelphia: A. Hart, 12th ed., 1850.

Lincoln Home Floor Plans, ca. 1887, Ferry & Henderson Architects, Inc., Springfield, Illinois.

Miscellaneous Treasury Accounts 1861-1865, Annual Repairs of the President's House, RG56, The National Archives, Washington, D. C. (Furnishing bills for the White House under the Lincoln administration.)

Morrison's St. Louis Directory for 1852 (and 1860).

Mrs. Putnam's Receipt Book; and Young Housekeeper's Assistant.  
Boston: Tickner and Fields, 1857.

Oldroyd, Lida A. "Lincoln's Home," The National Picket, I  
(July 1891) pp:7-8.

The Oldroyd Lincoln Memorial Collection - Schedule furnished  
by Mr. Oldroyd January 19, 1897, revised to August 28,  
1926. Washington, D.C., unpublished ms.

Palmer, Mrs. John. "Remembrances of Two Springfield Weddings  
of the Olden Time," Journal of the Illinois State  
Historical Society, III no. 2 (5 July 1910), 1910-1911:  
39-44.

Springfield, Illinois. Illinois State Historical Library.  
Recollections of Mary Edwards Brown.

Storke, E. G. The Family and Household's Guide. Auburn,  
New York: Auburn Publishing Co., 1859.

Turner, Justin G. and Linda Levitt Turner. Mary Todd Lincoln:  
Her Life and Letters. New York: Alfred A. Knopf,  
1972.

Washington, D.C. Library of Congress, Herndon-Weik Collection.

Washington, D.C. National Archives and Records Service. Seventh  
Decennial Census of the United States. Illinois:  
Sangamon County.

Webster's Encyclopaedia of Domestic Economy. London: Longman,  
Brown, Green and Longman, 1844.

Williams' Springfield Directory. Springfield, Illinois, 1860.

Zane, Charles S. "Lincoln As I Knew Him," Journal of the  
Illinois State Historical Society, XIV no. 1, (April  
1921): 74-79.



Decorative Arts Sources

Abernathy Bros. Illustrated Catalogue, Wholesale Price List.  
Leavenworth, Kansas, 1872.

Bishop, Robert. Centuries and Styles of The American Chair,  
1640-1970. New York: E. P. Dutton & Co., Inc.,  
1972.

Crossman, Carl L. The China Trade: Export Paintings, Furniture,  
Silver and Other Objects. Princeton: The Pyne  
Press, 1972.

Donald, Ellen Kirven, "Furniture From the Collection of the  
Lincoln Home National Historic Site: Condition  
Reports and Construction Drawings," unpublished ms.,  
National Park Service, June, 1978.

E. Howard & Co. Illustrated Catalogue of Clocks. Boston,  
1874, reprinted by American Clock & Watch Museum,  
Inc., Bristol, Connecticut. 1972.

Godden, Geoffrey. Encyclopedia of British Pottery and  
Porcelain Marks. New York: Crown Publishers,  
1964.

Hughes, G. Bernard, Victorian Pottery and Porcelain. New York:  
The MacMillan Co., 1959.

Kamm, Minnie. Old China. Grosse Point Farms, Michigan,  
privately published 1951.

Kunciov, Robert. Mr. Godey's Ladies. New York: Bonanza  
Books, 1971.

- Laidacker, Sam. Anglo-American China, Part II. Bristol, Pennsylvania, 1951.
- Lantz, Louise K. Old American Kitchenware, 1725-1925. Hanover, Pennsylvania: Everybody's Press, 1970.
- Lee, Ruth Webb. Early American Pressed Glass. Pittsford, New York: privately published 1931.
- Linton. The Modern Textile and Apparel Dictionary, New Jersey.
- Madden, Betty I. Arts, Crafts and Architecture in Early Illinois. Urbana, Chicago, London: University of Illinois Press, 1974.
- Olson, Sarah. William Howard Taft Home: Historic Furnishing Plan. Draft: National Park Service Report, Harpers Ferry Center, National Park Service. April, 1979.
- Ormsbee, Thomas H. English China and Its Marks. Great Neck, New York: Deerfield Editions, 1959.
- Ormsbee, Thomas H. Field Guide to American Victorian Furniture. Boston and Toronto: Little, Brown, & Co., 1952.
- Peirce, Donald C. "Mitchell and Rammelsberg, Cincinnati furniture manufacturers, 1847-1881," in Ian Quimby (ed.), American Furniture and Its Makers. Chicago and London: Henry Francis duPont Winterthur Museum, 1979.
- Peterson, Harold L. Americans at Home. New York: Charles Scribner and Sons, 1971.

Seth Thomas Clock Company. Illustrated Catalogue of Seth Thomas Clocks, Regulators and Time Pieces. Connecticut, 1863, with additions 1864-1872 and Tower Clocks, 1874, reprint by American Clock and Watch Museum, Bristol, Connecticut, 1973.

Swan, Susan Burrows. Plain and Fancy: American Women and Their Needlework, 1700-1850. New York: Holt, Rinehart and Winston, 1977.

Turner, Noel D. American Silver Flatware 1837-1910. New York: H. S. Barnes, 1972.

### Secondary Sources

Angle, Paul M. Here I Have Lived. A History of Lincoln's Springfield 1821-1865. Springfield: The Abraham Lincoln Association, 1935.

Barrett, J. H. Life of Abraham Lincoln. Cincinnati: Moore, Wilstach, Baldwin, 1864.

Bearss, Edwin C. Historic Structure Report: Lincoln Home National Historic Site, Illinois. Denver Service Center, National Park Service, July, 1973.

Blankmeyer, Helen Van Cleave. "Health Measures in Early Springfield," Journal of the Illinois State Historical Society, XLIV (Winter, 1951): 323-331.

Bowen, A. L. "A. Lincoln: His House," Lincoln Centennial Papers. Springfield, 1925.

Brown, Virginia Stuart. "Notes on the Restoration of Lincoln's Home," unpublished ms., Illinois State Historical Library. Springfield, Illinois.

- Brown, Virginia Stuart. Through Lincoln's Door. Springfield, 1953.
- Donald, David. Lincoln's Herndon. New York: Alfred Knopf, 1948.
- Duncan, C. Milner. Lincoln and Liquor. New York: The Neale Publishing Co.: 1920.
- Frank, John Paul. Lincoln As A Lawyer. Urbana: University of Illinois Press: 1961.
- Goff, John S. "The Education of Robert Todd Lincoln," Journal of the Illinois State Historical Society, LIII, no. 4 (Winter, 1960): 341-360.
- Hagen, Richard S. "Back-Yard Archeology at Lincoln's Home," Journal of the Illinois State Historical Society, XLIV, no. 4 (Winter, 1951).
- Hagen, Richard S. "What A Pleasant Home Abe Lincoln Has," Journal of the Illinois State Historical Society, XLIV, no. 4 (Spring, 1955).
- Helm, Katherine. Mary, Wife of Lincoln. New York and London: Harper and Brothers, 1928.
- Herndon, William H. and Jesse W. Weik. Abraham Lincoln: The True Story of a Great Life, 2 vols. New York: D. Appleton & Co., 1896.
- Hickey, James T. "Notes on Lincoln Home," unpublished ms., Illinois State Historical Library, Springfield, Illinois.

Hickey, James T. "The Lincolns' Globe Tavern, A Study in Tracing the History of a Nineteenth Century Building," The Journal of the Illinois State Historical Society, LVI (Winter, 1963): 629-654.

Hickey, James T. and King V. Hostick. The Lincoln Home. Springfield, Illinois: privately published 1964.

Holland, Josiah G. The Life of Abraham Lincoln, Springfield, Massachusetts: G. Bill, 1866.

Kunhardt, Dorothy Meserve and Philip B. Kunhardt, Jr. Twenty Days. New York: Harper and Row, 1965.

Lamon, Ward H. The Life of Abraham Lincoln: From His Birth to His Inauguration as President. Boston: J.R. Osgood, 1872.

Lincoln Lore. Fort Wayne, Indiana.

Lincoln Home, National Historic Site, Springfield, Illinois, Final Interpretive Prospectus, National Park Service, October, 1976.

Lincoln Home National Historic Site, Illinois, Master Plan, National Park Service, February, 1970.

Morrow, Honore Willsie. Mary Todd Lincoln. New York: William Morrow & Co., 1928.

Nicolay, John G. and John Hay. Abraham Lincoln, A History. 10 Vols. New York: The Century Company, 1890.

The Old Capitol, 1840-1876: Springfield, Illinois. Springfield: Illinois State Historical Society for the Abraham Lincoln Association.

- Oldroyd, Osborn H. "Raising the Stars and Stripes Over the Lincoln Homestead, Springfield, Illinois, October 16, 1889," unpublished ms., Illinois State Historical Library, Springfield, Illinois.
- Pratt, Harry E. Concerning Mr. Lincoln. Springfield, Illinois: The Abraham Lincoln Association, 1944.
- Pratt, Harry E., Editor. "The Lincolns Go Shopping," Journal of the Illinois State Historical Society, XLVIII, no. 1 (Spring, 1955).
- Pratt, Harry E. The Personal Finances of Abraham Lincoln. Springfield, Illinois. The Abraham Lincoln Association, 1943.
- Randall, Ruth Painter. I, Mary. Boston and Toronto: Little, Brown & Co., 1959.
- Randall, Ruth Painter. Lincoln's Sons. Boston and Toronto: Little, Brown & Co., 1955.
- Randall, Ruth Painter. Mary Lincoln: Biography of a Marriage. Boston: Little, Brown, 1961.
- Sandburg, Carl and Paul M. Angle. Mary Lincoln Wife and Widow. New York: Harcourt, Bruce & Co., 1932.
- Scott, Kenneth. "Candidate Lincoln in the New York Press," The New York Historical Society Quarterly, XLIII (January 1959): 5-37.
- Scott, Kenneth. "Lincoln Home in 1860," Journal of the Illinois State Historical Society, XLVI (Spring, 1963).

Temple, Wayne C. "Lincoln in the Census," Lincoln Herald, LXVIII  
(Fall, 1966): 135-140.

Volk, Leonard M. "The Lincoln Life-Mask and How It Was Made,"  
Century Magazine, XXIII, no. 2 (December 1881).

Wallace, Joseph. Past and Present of the City of Springfield  
and Sangamon County, Illinois. 2 vols., Chicago:  
S.V. Clarke, 1904.

Wilson, Rufus Rockwell. What Lincoln Read. Washington, D. C.:  
National Capital Press, 1932.





ILLUSTRATIONS

PLATE I

Front Parlor from  
Frank Leslie's Illustrated Newspaper,  
March 9, 1861.

Photo courtesy of the Library of Congress.



PLATE II

Back Parlor from  
Frank Leslie's Illustrated Newspaper,  
March 9, 1861.

Photo courtesy of the Library of Congress.



PLATE III

The Sitting Room from  
Frank Leslie's Illustrated Newspaper,  
March 9, 1861.

Photo courtesy of the Library of Congress.

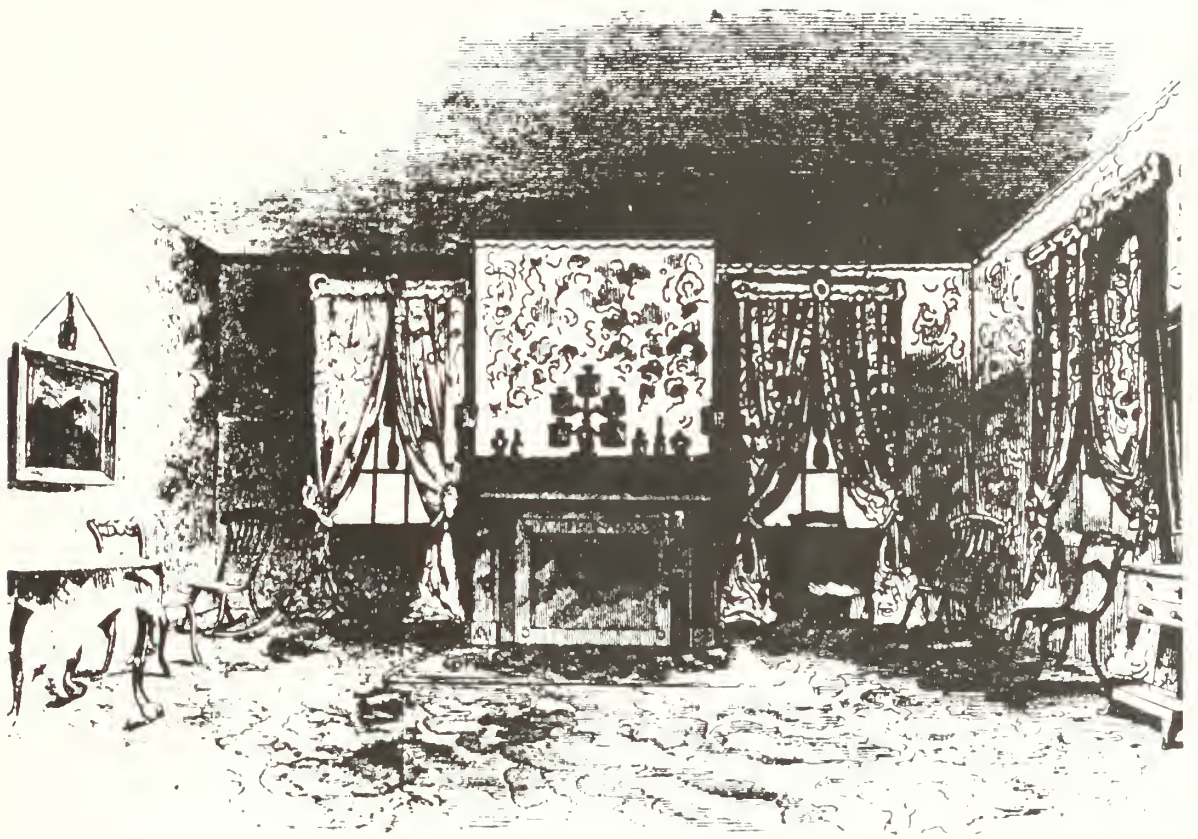

PLATE IV

Parlors draped for Lincoln's Funeral, ca. 1865,  
attributed to Alfred Waud, Waud Collection,  
LC-USZ62-68106, Division of Prints and  
Photographs, Library of Congress, Washington, D. C.

Photo courtesy of the Library of Congress.



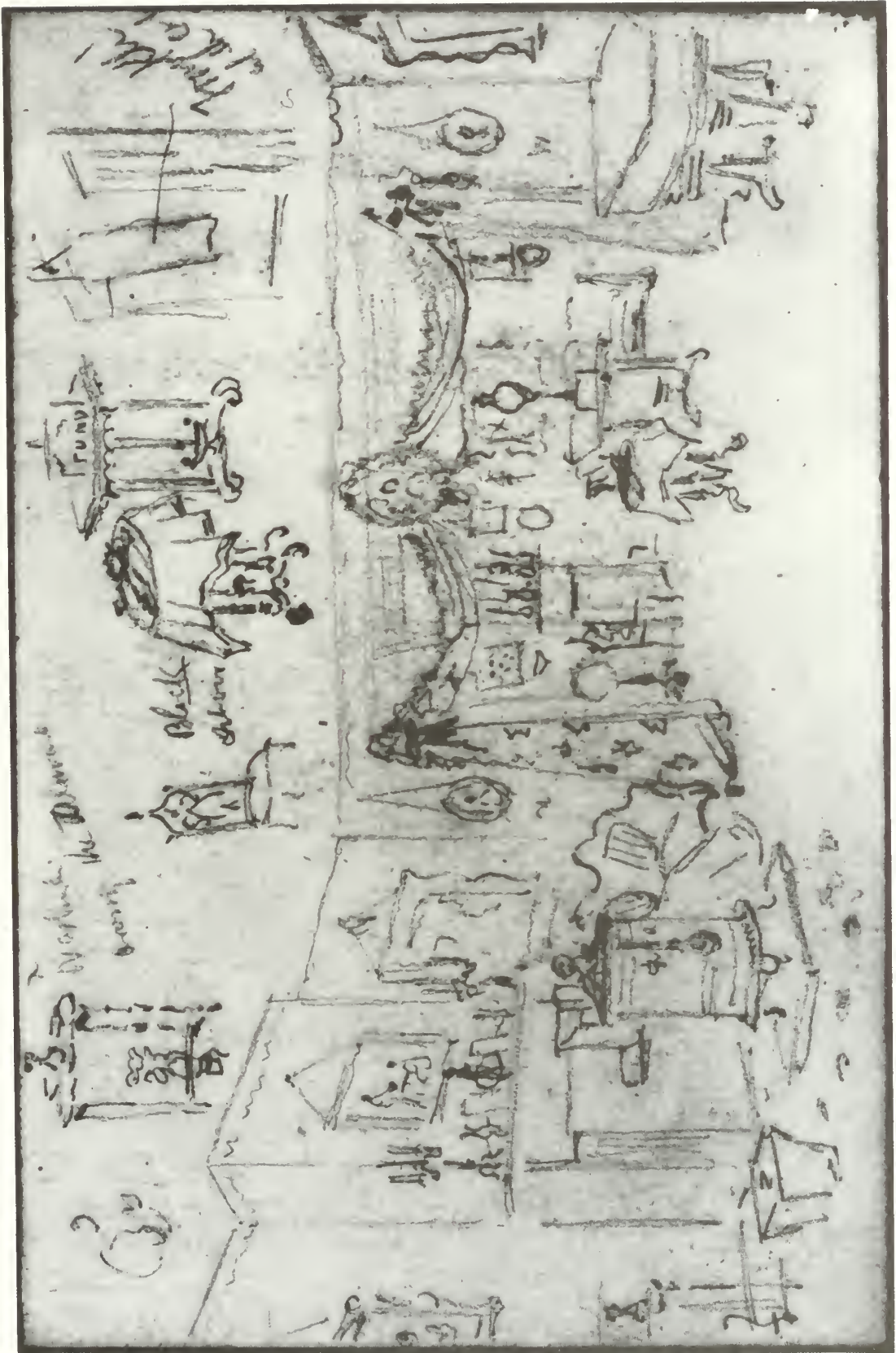

PLATE V

Unidentified room, possibly South Front Bedroom, ca. 1865, attributed to Alfred Waud, Waud Collection, LC-USZ62-68105, Division of Prints and Photographs, Library of Congress, Washington, D. C.

Photo courtesy of the Library of Congress.

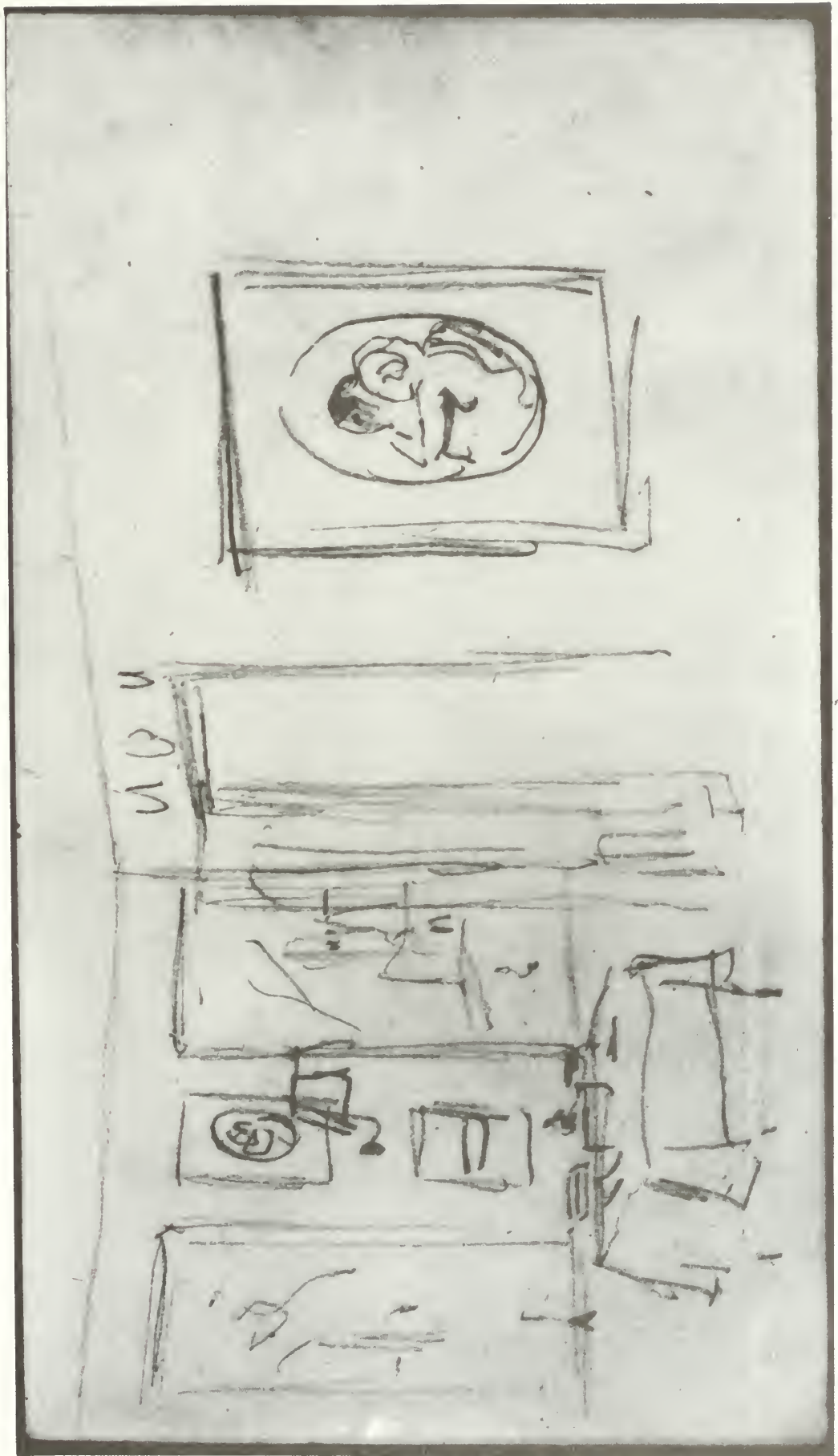
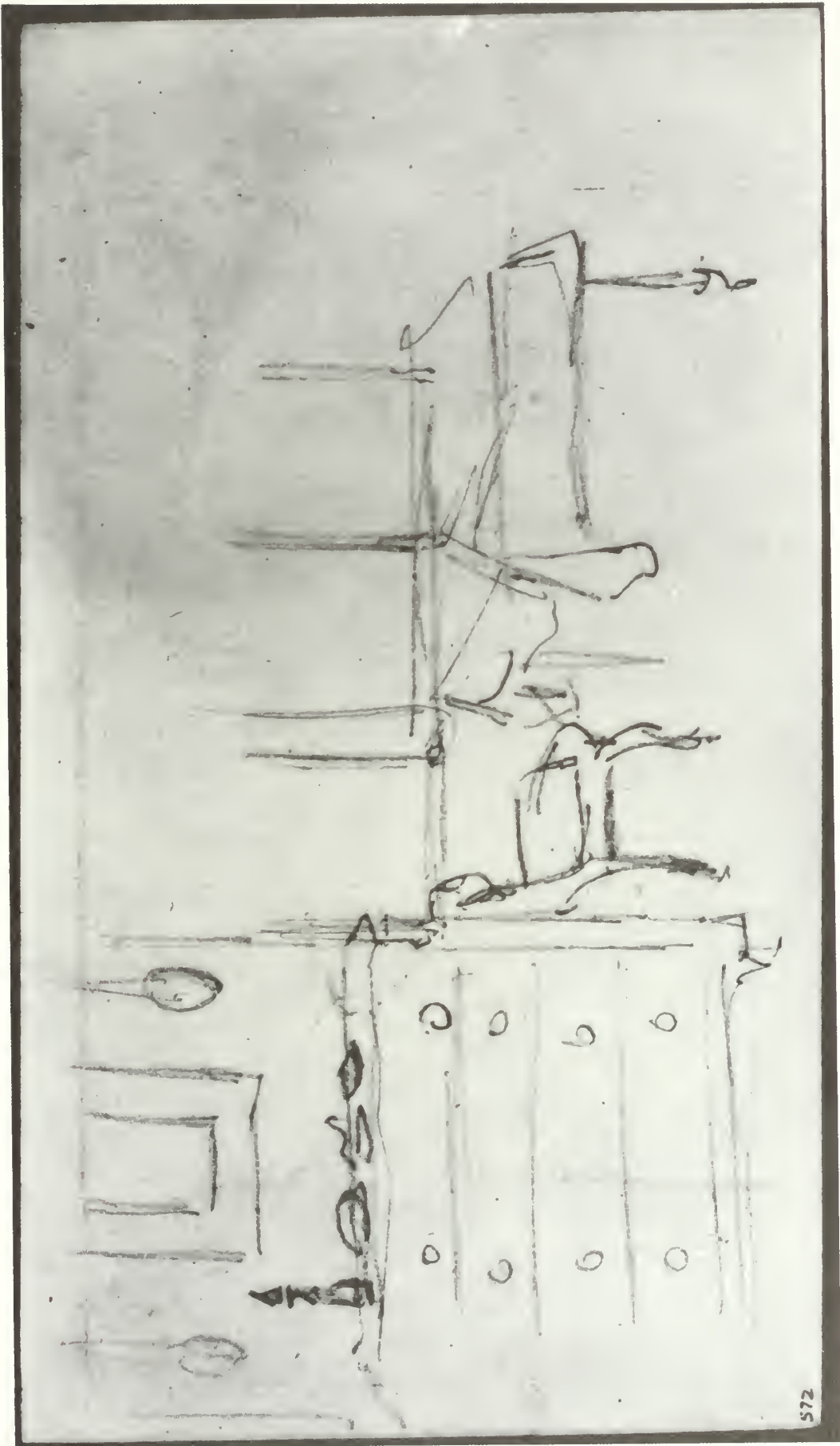

PLATE VI

Unidentified room, possibly Lincoln's Bedroom,  
ca. 1865, attributed to Alfred Waud, Waud Collec-  
tion, LC-USZ62-68104, Division of Prints and  
Photographs, Library of Congress, Washington, D. C.

Photo courtesy of the Library of Congress.



572



PLATE VII

Globe Tavern, ca. 1865, attributed to Alfred Waud,  
Waud Collection, LC-USZ62-68107, Division of Prints  
and Photographs, Library of Congress, Washington, D. C.

Photo courtesy of the Library of Congress.

Wright House



567

PLATE VIII

Sofa, Accession No. 1920.246,  
Chicago Historical Society,  
Chicago, Illinois.

Photo courtesy of the Chicago Historical Society.



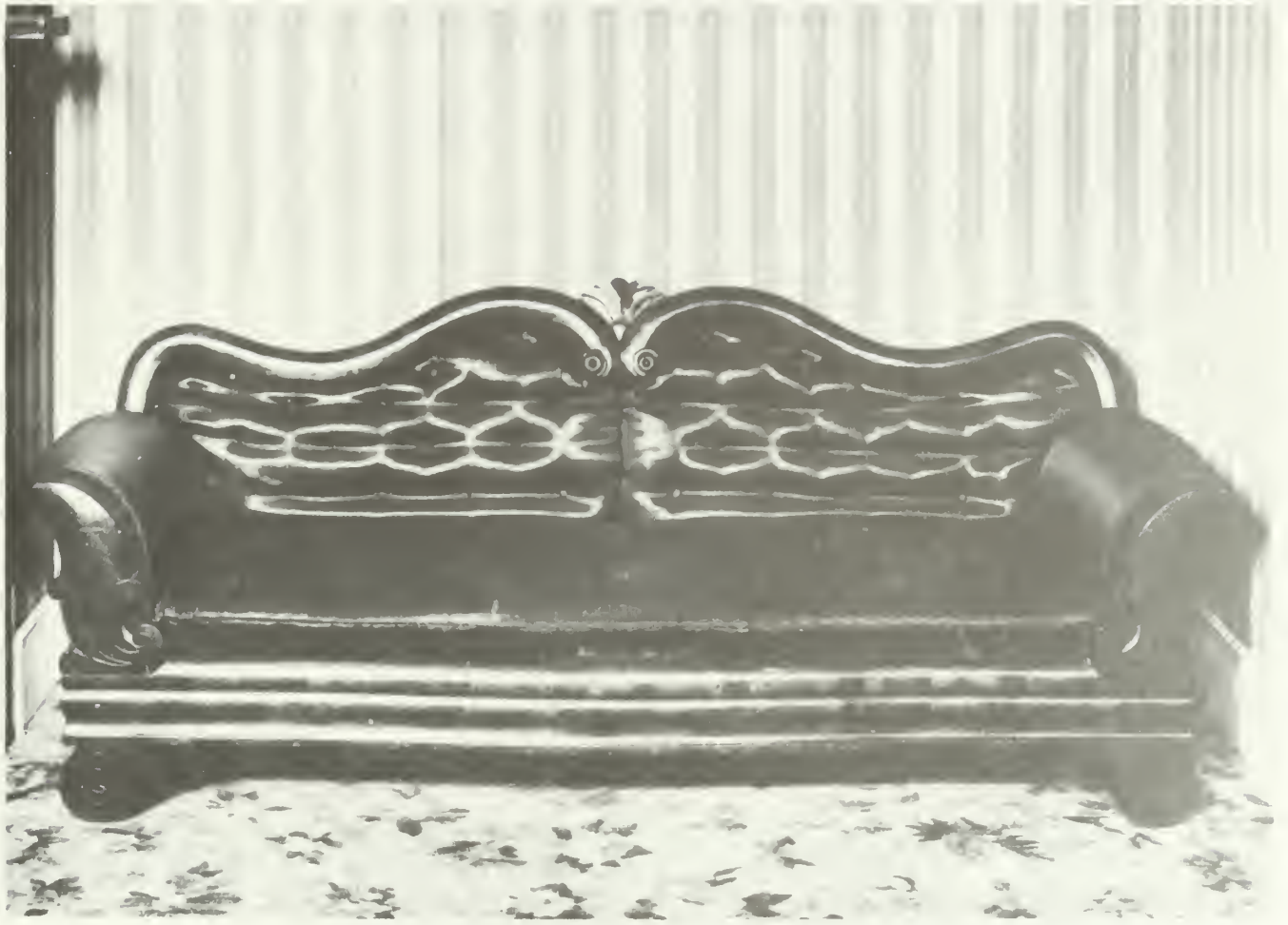
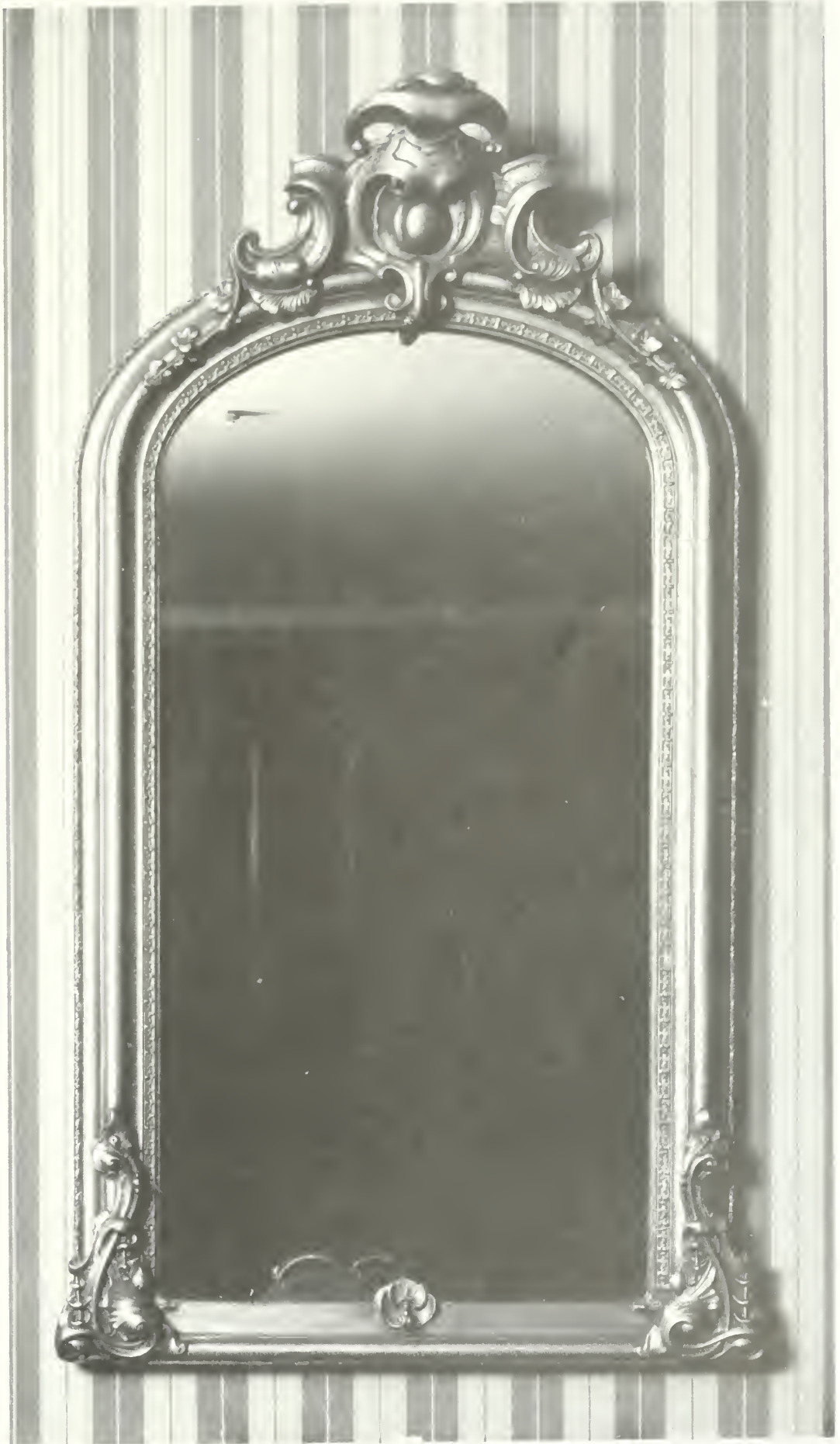

PLATE IX

Mirror, Accession No. 1960.100,  
Chicago Historical Society,  
Chicago, Illinois.

Photo courtesy of the Chicago Historical Society.







DATE DUE

AUG 20 1992	
<del>Red</del> SEP 14 1992	
<del>JUL 05 2000</del>	
<del>JAN 02 2002</del>	
MAY 02 2002	
OCT 13 2002	



As the nation's principal conservation agency, the Department of the Interior has responsibility for most of our nationally owned public lands and natural and cultural resources. This includes fostering wise use of our land and water resources, protecting our fish and wildlife, preserving the environmental and cultural values of our national parks and historical places, and providing for the enjoyment of life through outdoor recreation. The department assesses our energy and mineral resources and works to ensure that their development is in the best interests of all our people. The department also promotes the goals of the Take Pride in America campaign by encouraging stewardship and citizen responsibility for the public lands and promoting citizen participation in their care. The department also has a major responsibility for American Indian reservation communities and for people who live in island territories under U.S. administration.

NPS D-16 September 1990.

